

Outline of the A360

1.1 Introduction

This chapter provides the outline features and operation of the A360 including the BIOS Setup program and other system options.

The A360 all-in-one notebook offers the latest in advanced portable computing and multimedia technology that even outperforms most desktop computers. It incorporates the latest Intel Pentium-III FC-PGA 370 Processor or Intel Celeron FC-PGA 370 processor and fully compatibles with an entire library of PC software based on operating systems such as MS-DOS, Windows 98/Me, and Windows NT/2000. It also runs on future versions of Windows. It comes with a built-in Windows 98/Me keyboard, glide pad pointing device, sound system, PCMCIA slots, USB (Universal Serial Bus) port, IEEE 1394 port, advanced power management and more new multimedia features.

1.2 Feature Highlights

The A360 includes a variety of innovative features:

Features	Description
CPU	Intel ®Pentium-III, Celeron Processors using FC-PGA 370 packaging at 933 MHz/1GHz/1.13GHz+ for Pentium-III at 766/800/850/900/950+ MHz for Celeron
Cache Memory	<ul style="list-style-type: none"> On-die secondary level cache (256-KB) for Pentium-III, Tualatin On-die secondary level cache (128-KB) for Celeron
Bus Architecture	32-bit PCI / PCI-to-ISA Bus Architecture
Bus Speed	100 / 133 MHz Front Side Bus
System Memory	<ul style="list-style-type: none"> Two memory slots for 144-pin SODIMM SDRAM (3.3V) Use PC-100/133 SDRAM (64 / 128 / 256 MB) Upgradeable to 512 MB
Display	<ul style="list-style-type: none"> 12.1" SVGA TFT Color LCD at 800x600 pixel resolution 13.3"/14.1" XGA TFT Color LCD at 1024x768 pixels resolution Maximum 32-bit True Color display at 1024x768 pixel resolution Brightness controls via hot-key function LVDS Interface
VGA	<ul style="list-style-type: none"> High performance S3 Savage4 (Integrated in Twister) with AGP 4X and SMA support. 0/8/16/32 MB VRAM sharing from SDRAM (Using system memory; SMA Technology) (Twister spec is 2~32 MB). Up to 1280x1024 resolution for external CRT monitor at 16M colors (32-bit True Color) 128bit Graphics Engine Support Dual View and Dual Video

Outline of the A360

HDD	<ul style="list-style-type: none"> • Built-in (internal) 2.5-inch Format; 9.5mm in Height Enhanced IDE hard drive • Supports Bus Mastering Ultra-DMA 33/66 feature for LBA
CD-ROM / DVD-ROM / CD-RW	<ul style="list-style-type: none"> • Built-in ATAPI IDE 24X+ Speed CD-ROM drive; or • Built-in ATAPI IDE 8X+ Speed DVD-ROM drive; or • Built-in ATAPI IDE 4X+ Speed CD-RW drive; or • Built-in ATAPI IDE Combo CD/DVD/CD-R/CD-RW drive
FDD	Built-in 3.5-inch 1.44MB floppy disk drive
Keyboard	<ul style="list-style-type: none"> • 19mm Pitch and 3mm Travel • Built-in 87 / 90-key Windows keyboard • Compatible with IBM enhanced 101 / 102-key keyboard
Pointing Device	<ul style="list-style-type: none"> • Integrated Touch pad (Glide pad) with 2 select click buttons and 1 scroll button • PS/2 mouse interface
PCMCIA Slot	<ul style="list-style-type: none"> • Double-deck PCMCIA 2.1 card slots that support two Type II or one Type III PC cards • 32-bit CardBus PCI local bus technology / Supports mixed voltage PC cards (5V and 3.3V)
I/O Port	<ul style="list-style-type: none"> • Includes the following standard I/O ports: <ul style="list-style-type: none"> ✓ 1 x 9-pin Serial Port (COM1) ✓ 1 x 25-pin Printer Port (LPT1) ✓ 1 x DC-in Jack ✓ 1 x mini-DIN 6-pin PS/2 Port (K/B or Mouse) ✓ 1 x 15-pin VGA Port (CRT) ✓ 2 x standard USB 1.1 Ports ✓ 1 x RCA TV-Out ✓ 1 x IEEE1394 Port (Reserved) ✓ 1 x IR Port (Reserved)
Audio System	<ul style="list-style-type: none"> • 16-bit full-duplex sound controller with Woofer (heavy bass) voice output, software wavetable function, and FM stereo synthesizer. • Compatible with Sound Blaster and Sound Blaster Pro • Integrated 2-way high quality paper cone stereo speakers (>1W) with sound boxes and mono microphone • Supports optional Audio-DJ to play audio CD like CD player without powering on the whole computer. • Includes the following: <ul style="list-style-type: none"> ✓ Microphone-in jack (MIC-IN) ✓ Headphone / Audio line-out jack (S/PDIF OUT) • Volume thumb-wheel knob control

Outline of the A360

Features	Description
Power System	<ul style="list-style-type: none"> • Universal Auto-switching 60W/65W AC Adapter (100V – 240V) / Auto-charging capability • Rechargeable Ni-MH (4500mAh/9.6V) / Li-Ion (3800mAh/14.4V) Battery Pack • Battery Life: 2 ~ 2.5 hours (Power Management Off) • Charging Time: 2.5 ~ 3 hours quick charge (computer off)
Power Management	<ul style="list-style-type: none"> • ACPI 1.0B Ready • SMM (Intel System Management Mode) fully supported • Suspend-to-RAM and Suspend-to-Disk feature Suspend hot-key function / Battery Low Auto Suspend • Cover Switch (Suspend/CRT-only) function
LED Indicator	8 x LED Status Indicators for Power Source, Battery Charge, E-Mail, IDE, FDD, Caps Lock, Scroll Lock, Num Lock (LCD x 3 + Machine Base x 5)
Optional Module	<ul style="list-style-type: none"> • 56Kbps Fax / Data Internal Modem with V.90 support • 10 Base-T / 100 Base-TX LAN Mini PCI • Combo Modem / LAN Mini-PCI • Bluetooth Module • DVD-ROM Device Pack • CD-RW Device Pack • Combo DVD / CD-RW Device Pack • Audio DJ Panel • USB Port Replicator

Outline of the A360

1.3 System Configuration

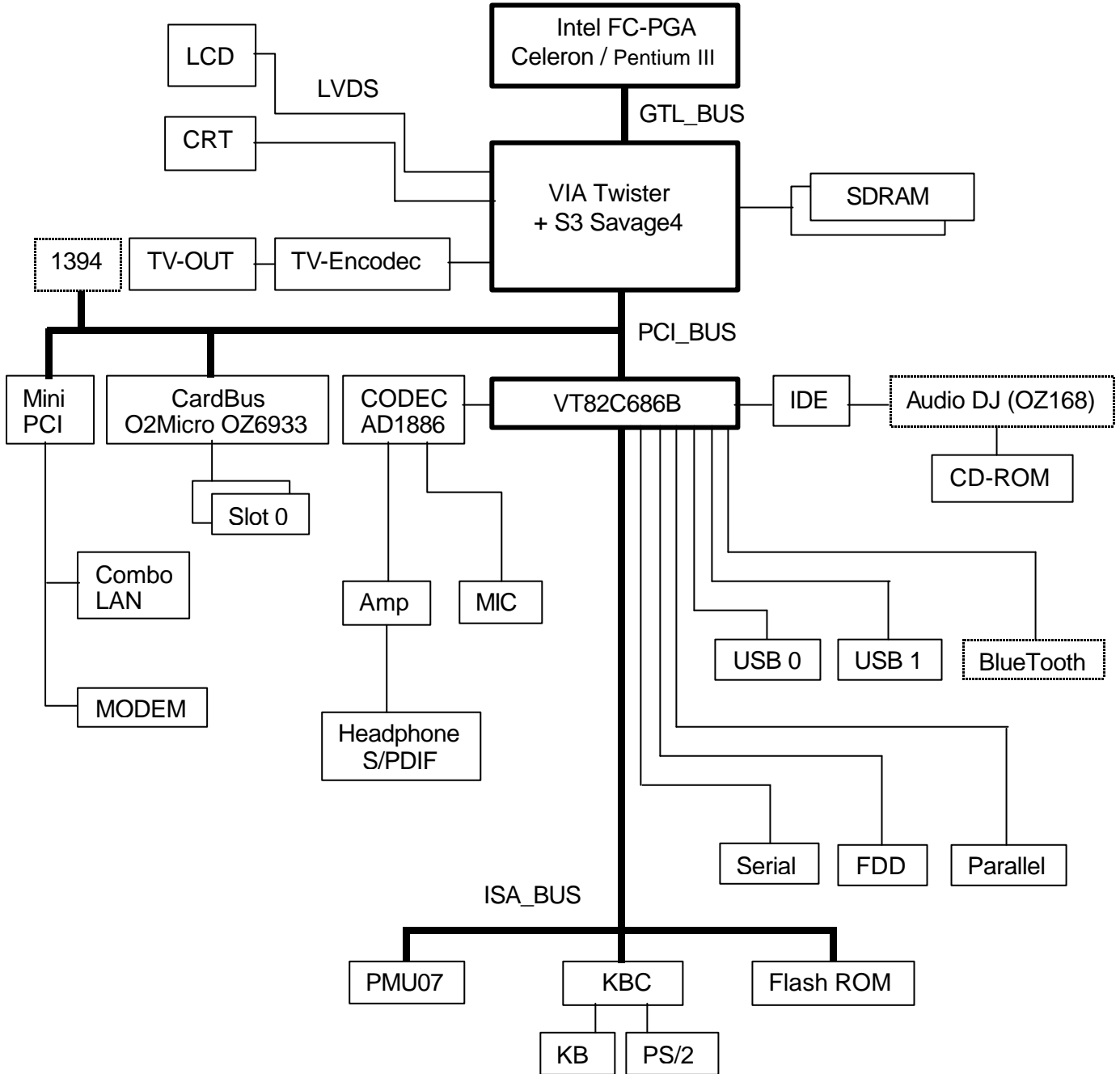

Figure 1-1 System Configuration Diagram

Outline of the A360

1.4 Quick Tour of the Notebook

Please take a moment to become familiar with the location and purpose of every control, the LED status panel, connectors and ports, which are illustrated in this section. It is recommended to first go through the User Guide of the notebook, which is shipped together with the notebook for information on how to operate its features.

1.4.1 Inside the Notebook

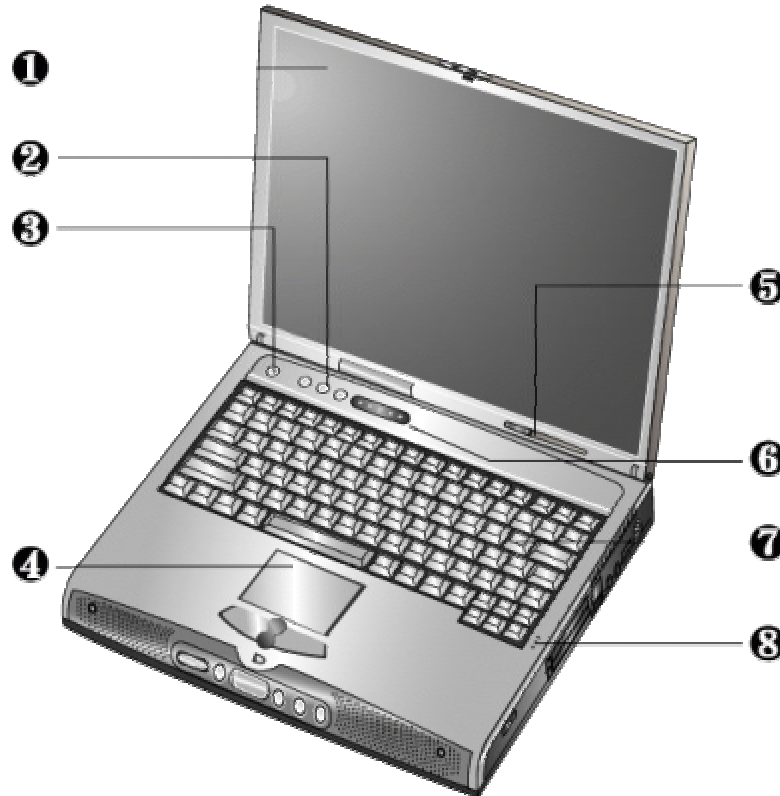

To open the LCD cover of the notebook, find the cover latch located at the front center of the LCD cover. Push the latch to the right to release and tilt the LCD cover up. Inside, you will see the LCD display panel, keyboard, touch pad, status LED, and power switch.

①	Color LCD Panel	②	Easy Buttons	③	Power On / Resume Button
④	Glide Pad Pointing Device	⑤	Power Status LED Indicator	⑥	Status LED Indicator
⑦	Keyboard	⑧	Integrated Microphone		

Figure 1-2 Inside the Notebook

Color LCD Display Panel

The notebook comes with several LCD option sizes at SVGA (800x600) or XGA (1024x768) active-matrix TFT color liquid crystal display (LCD). The LCD can be a 12.1" TFT (Thin Film Transistor) color LVDS with 800x600 SVGA (Super Video Graphics Array) resolution panels, or 13.3" or 14.1" TFT color LVDS with 1024x768 XGA (Extended Graphics Array)

Outline of the A360

resolution panels. You can adjust and tilt (up to 180°) the LCD screen panel to your desired viewing position.

The notebook uses S3 4X AGP VGA graphics controller that owns maximum 32MB video memory with SMA technology. All LCD models can support 16M colors or maximum 32-bit true color at 1024x768 resolution. The notebook also supports simultaneous display of the LCD with the external VGA monitor.

The LCD screen also uses CCFT (Cold Cathode Fluorescent Tube) backlighting which consumes much of the electrical power of the notebook. To save battery power, the system has an advanced power management feature that switches off the LCD when there is no system activity for a predetermined amount of time.

You adjust the brightness level of the LCD by pressing the display control hot-keys. You activate the hot-keys by pressing the <Fn> key along with another function key:

- <Fn> + <F8> Key = Increases the brightness of the LCD display
- <Fn> + <F9> Key = Decreases the brightness of the LCD display

Easy Buttons

There are three easy buttons, two use for accessing Internet and e-mail functions instantly and easily, the other one lets you define certain functions by yourself. Descriptions of the easy buttons appear in the latter part of this section.

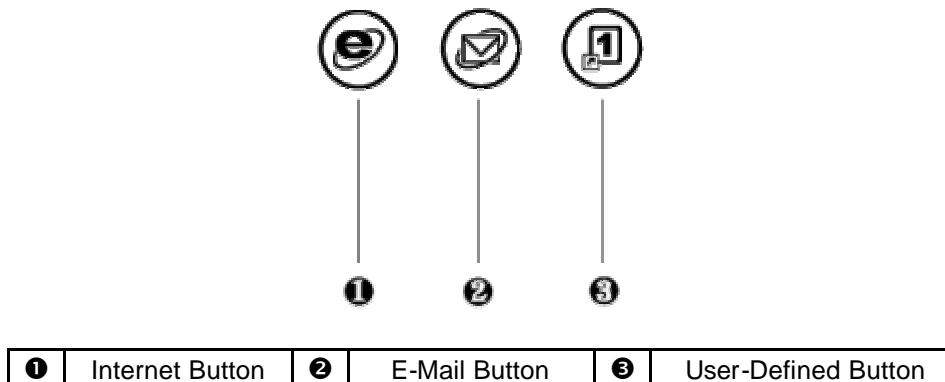

Figure 1-3 Easy Button

- Internet Button
This technology is designed specifically for providing a very convenient way in connecting Internet only by pressing Internet button as shown in the graphics. For more understanding and interesting, you can refer Section 2.5 of user manual to recognize the driver installation procedures in activating Internet button.
- E-mail Button
This is the most convenient way to access the outlook utility just by pressing this button. You can simplify several procedures in entering into Microsoft Outlook environment.

Outline of the A360

- User-Defined Button

You can define this button to activate command file (like execution file or batch file) by yourself.

Power Button

Press the Power button either to power on or power off the system. The Power button is also a “Smart” switch, meaning that it recognizes when the system is in Suspend mode. If in Suspend mode, pressing the Power button will bring it out of Suspend mode and resume to the system’s last state. You can set the function of power button from the power management setting in Windows Control Panel. Always check the Power LED after pressing the power button to know the power status of the notebook.



If you are unable to power off the system, use the power override function. Press the power button and hold it in place for four seconds. The system will then power off.

Glide Pad Pointing Device

Built in just below the keyboard panel is the glide pad pointing device. The left and right select buttons of the glide pad is found below the glide pad surface. The left select button is configured (by default) as the left button you normally click on the mouse while the select key to the right is configured as the right button. The scroll button makes it easy to browse upwards or downwards in the software screen.

To move cursor, place your finger lightly on the glide pad and move in the desired direction. If you reach the end of the pad, lift your finger and place it back down on the other side.

The glide pad is compatible with the standard PS/2 mouse and can be activated using the normal DOS or Windows PS/2 mouse driver. You can also disable the glide pad in the BIOS Setup program.



You can execute a left button click function by simply tapping on the glide pad surface once. Refer to the User Guide of the notebook for more information.

Outline of the A360

Power Status LED Indicator

Located just in front of the palmrest assembly, you will find three LEDs for the power and battery charge status. These LEDs are positioned to be visible even if the LCD cover is closed.

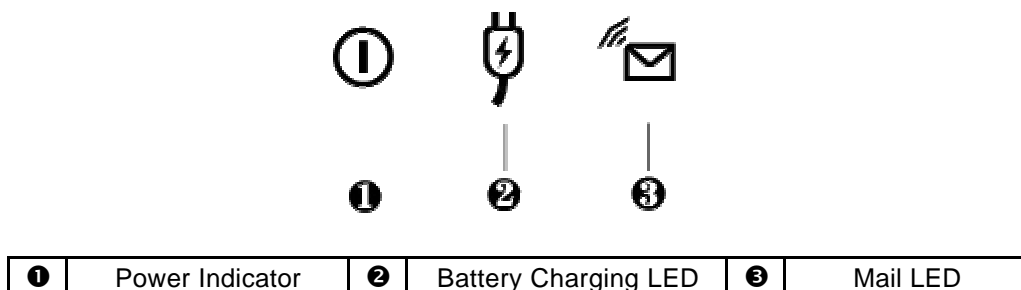

Figure 1-4 Power Status LED Indicator

- Power Indicator** – lets you know if power to the system is turned on and if system is in Suspend-to-RAM mode. This LED is positioned so that you can see it on both sides whether the LCD panel is opened or closed.
 - Lights green when the system is powered on using the AC adapter or battery.
 - Lights green blinking when in Suspend to RAM (or Suspend to Disk) if you already created Save to Disk partition/file in HDD mode and critically low battery power. We strongly recommend that users create the partition/file "Save to Disk" as this will prevent your data from loss when power is critically low.
 - Lights orange when the battery power is low.
- Battery Charging LED** – lights to indicate battery in charging status.
 - Lights green to indicate the battery is charging.
 - Lights off to indicate the battery is fully charged or no battery installed.
- Mail LED** – Lights green to indicate that a new mail is arrived.

Status LED Panel

The Status LED Panel keeps you informed of the notebook's current operating status. Each LED is marked with an icon to designate a system status.

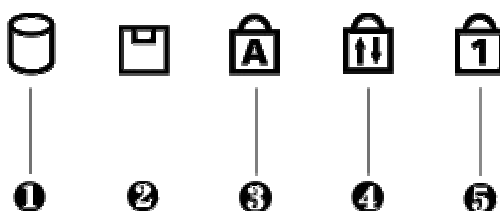

Figure 1-5 Status LED Panel Icons

Outline of the A360

Icon	Represents	Indicates
❶	IDE Drive Access	This LED will turn on when the system is accessing the hard disk drive (HDD) or CD-ROM / DVD-ROM / CD-RW.
❷	Diskette Drive Access	This LED will turn on when the system is accessing the floppy disk drive (FDD).
❸	Caps Lock	This LED will turn on when the Caps Lock key is activated. When activated, all alphabet keys typed in will be in upper case or in capital letters.
❹	Scroll Lock	This LED will turn on when the Scroll Lock key is activated.
❺	Num Lock	This LED will turn on when the Num Lock key is activated. When activated, the embedded numeric keypad (blue print numeric keys) will be enabled.

Keyboard Panel

- Standard QWERTY-key layout and full-sized 87/90 keys keyboard with Windows hot-keys, embedded numeric keypad, hot keys, inverted “T” cursor arrow keys, and separate page screen control keys.
- Wide extra space below the keyboard panel for your wrist or palm to sit-on comfortably during typing. (The keypad F4, F5, F7 on the following keyboard should no words print on it.)

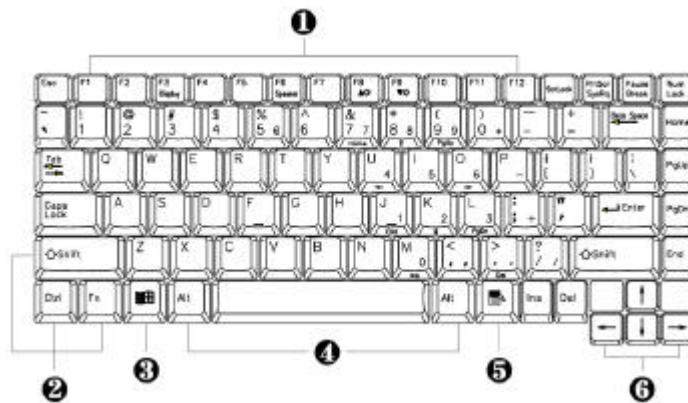

❶	Function Keys	❷/❹	Control Keys	❸	Windows Start Menu Key
❺	Windows Short-cut Key	❻	Cursor Control Keys		

Figure 1-6 Keyboard Layout

The notebook keyboard is a little bit different from a standard desktop keyboard. Aside from the normal alphanumeric characters and the standard keyboard function keys, the notebook keyboard includes an embedded numeric keypad, and special function keys that activates by pressing the **<Fn>** key together with another key. These special function keys or “hot-keys” allow you to control and adjust some of the functions of the notebook like display controls, power saving features, and others.

- (1) **Function Keys** —These function keys, out of **<F1>** through **<F12>**, are available on the notebook keyboard. These keys also work together with the **<Fn>** key to activate special functions. The following function-key combinations are pre-programmed:

Outline of the A360

Hot Key	Function	Handler
Fn + F3	Toggle Display (LCD/CRT/Simul)	BIOS Handler
Fn + F5	Display stretching	BIOS Handler
Fn + F6	Speaker On/Off	BIOS Handler
Fn + F8	Brightness Increase	Controlled by PMU07
Fn + F9	Brightness Decrease	Controlled by PMU07
Fn + F12		
Fn + Power button	System Suspend to disk	BIOS Handler

- (2) **Control keys** – <Ctrl>, <Alt>, <Fn>, and <Shift> keys are controls used in conjunction with other keys to change their functions. To use control keys, press and hold the control key while pressing another key. For example, “Press <Ctrl>+ <C>” means to hold down the <Ctrl> key and type the letter <C>.
- (3) **Windows keys (Windows Start Menu Key)** – Use this key to activate the Start Menu of Windows.
- (4) **Shortcut/Application key**– provides quick access to shortcut menus. (This key acts like a right mouse button.)
- (5) **Cursor Control keys** – Cursor control keys let you position the cursor on the screen where you want. On the screen, the cursor is a blinking underline, block, or vertical bar depending on the application.
- (6) **Typewriter keys** – Typewriter keys (also called *alphanumeric* keys) are used to enter text and characters. Keys with blue print on them behave differently when combined with control keys or the <Fn> key.
- (7) **Numeric Keypad** – Pressing <NumLock> on the keyboard activates the embedded numeric keypad numbers and functions printed in blue on top of the keys. When you press <NumLock> again, the keys revert to their normal functions as typewriter keys.

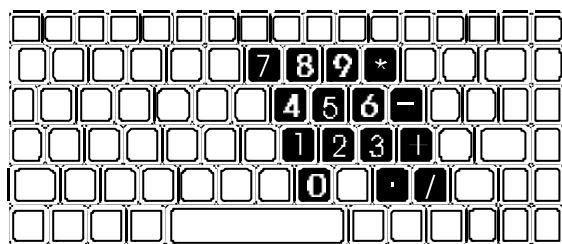

Figure 1-7 Embedded Numeric Keypad

Integrated Microphone

This allows you to instantly record voice annotations (normally saved as WAV files) and later attached them to documents and presentation using the notebook integrated audio system and application software. Since the notebook also supports full-duplex audio capabilities, you can talk to the microphone and at the same time listen to others talk when connected to a speakerphone modem, Internet live chat, or video conferencing.

Outline of the A360

1.4.2 Front Side of the Notebook

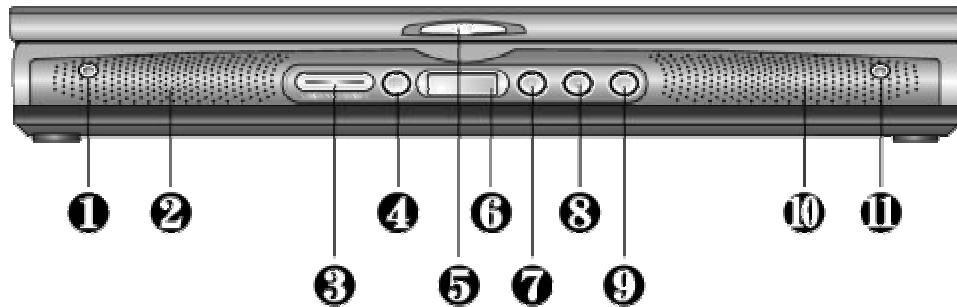

①/⑩	Woofer	②/⑩	Built-in Stereo Speakers	③	Lock On / Off Switch
④	Rewind Button	⑤	Cover Switch	⑥	Audio DJ Display
⑦	Forward Button	⑧	Stop Button	⑨	Play Button

Figure 1-8 Front Side of the Notebook

Woofer

These speakers produce heavy bass voice output for music listening.

Built-in Stereo Speakers

At the front left and right sides of the base unit are two built-in stereo mini speakers with sound boxes. The speakers are controlled by the audio controller of the notebook and activated by installing the audio driver. For adjusting the volume of the speakers, you can use the volume control program under Microsoft OS or by adjusting the thumb-wheel volume knob also found on the left side of the notebook.

Lock On / Off Switch

This Lock Switch executes two functions as to power on/off the Audio DJ CD player and to lock or unlock the Audio DJ status. To power on or off the Audio DJ CD player, slide the switch right aside. To lock or unlock the status of your Audio DJ, slide the switch left aside. When your Audio DJ is in locking status while the music is playing, no matter what button is pressed, the music still continues to play. The function of this switch is to prevent you from touching any button accidentally.

Remind Button

Press the button for reverting to previous music. Press and hold this button to fast rewind the audio CD.

Cover Switch

The Cover Switch is found inside the notebook assembly just underneath the latch opening where you insert the LCD cover hook. Whenever the LCD cover is closed, it activates the Suspend mode or switches the display to CRT if there is an external monitor connected.



When Suspend-to-RAM mode is activated, make sure not to leave the system for a long period when running at battery mode. The battery will continue to drain some power even in Suspend mode. It is better to save all files and shutdown the power instead or run Suspend-to-Disk mode.

Outline of the A360

Audio-DJ Display

The display shows the number of the music currently playing.

Forward Button

Press the button for playing the next music. Press and hold this button to fast forward the audio CD

Stop Button

Press the button to stop the music.

Play Button

Press the button to play the music.

i The function of Audio DJ can be workable either in Windows system or operate it without powering on the computer. For execute this function, you should first install the Easy Button driver. Please refer to Section 5 of Chapter 2 of user manual for installation procedures. However, if your OS is Windows 98, you should download and install the "Windows Media Player 7" from Microsoft's Website to activate this function.

1.4.3 The Right Side of the Notebook

The right side of the notebook computer offers the features shown in the following figure.

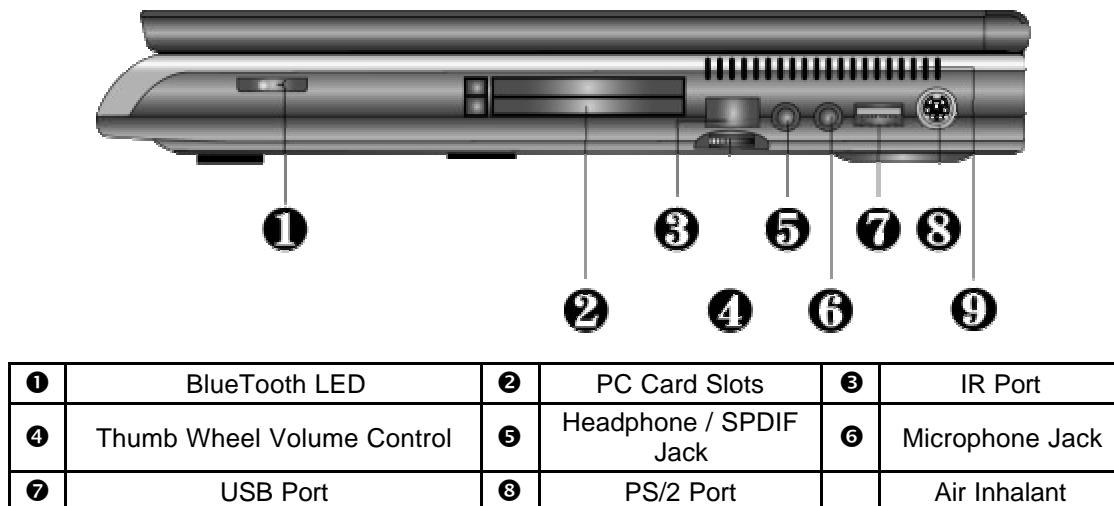

Figure 1-9 Right Side of the Notebook

BlueTooth LED

The LED is light when you activate with the Bluetooth function.

PCMCIA Slot Compartment

The PCMCIA slot compartment houses two card slots that support two PCMCIA Type II cards at the same time or one Type III card. The notebook uses a CardBus PCMCIA controller that supports 5V and 3V 32-bit CardBus and 16-bit PC cards. The PCMCIA slot

Outline of the A360

compartment comes with vertical sliding doors so you can directly insert the PC card. If you are using a Type III card, insert the Type III card into the top slot.

To remove the inserted PC card, slightly push the button found on the right side of the PC slot to release the eject button. Then push it again to release the PC card. The upper left button releases the card on the top slot while the lower right button releases the card on the bottom slot. When the PC card has moved out a space out of the slot, hold the edges of the card and slowly slide it out.



For full functionality of PC cards, always ask for the latest driver from your PCMCIA card dealer or download it from their Internet website.



For network PC cards, you need first to stop the device under the PC Card properties of Windows Control Panel. Otherwise, this may cause system hang or system fatal error.

IR Port

Wireless data transfer of files between your notebook computer and an IR-equipped device or notebook computer. You can also print to an IR-equipped printer without using cables. The SIR mode provides up to 115.2Kbps of data transfer rate.

Thumb-Wheel Volume Control

The notebook includes a thumb-wheel volume knob to easily adjust the volume level of the built-in speakers or the external earphone/headphone set.

Headphone Jack

This jack (1/8-inch mini-jack) allows you to connect an external headphone, earphone, or powered speakers for personal listening.



Turn the volume level down first before placing the earphone or headphone set into your ear. Then adjust the volume according to your listening level.



If you get noise feedback on the external speaker, try to lower down the volume knob on the speaker and adjust the volume using the notebook's volume control buttons or the software.

Microphone Jack

The microphone jack (1/8-inch mini-jack) allows you to connect an external microphone with 600-ohm dynamic in place of the built-in microphone of the notebook for monophonic sound recording directly into your notebook computer. The external microphone provides lesser recording noise compared to the built-in microphone of the notebook.



Plugging in an external microphone disables the internal microphone.

USB (Universal Serial Bus) Ports

The USB (Universal Serial Bus) Port is a port with the symbol . This 4-pin slim port allows you to connect multiple USB devices through daisy chaining or through a USB hub and use them all simultaneously. The USB specification states it can support up to 127 USB devices running at

Outline of the A360

up to 12Mbps. This notebook provides two USB ports.

i When you resume the system from suspend mode, the USB port may not initialize properly. If in case the USB device does not work, unplug and plug the USB device again. This is a known bug released by Intel and Microsoft Windows.

PS/2 Port

Use the standard PS/2 port to connect an external PS/2-style mouse, PS/2-style keyboard, or PS/2 style Numeric Keypad to the system. With a Y-cable adapter which user can purchase at local electronic store, user can connect any combination of two of these devices at the same time. For non-PS/2 keyboard, you need to use a keyboard adapter that converts the DIN-type connector to PS/2 connector.

Air Inhalant

Inhale the air into your computer to keep it within operating temperature.

i Do not block the fan while the notebook is in use.

1.4.4 The Left Side of the Notebook

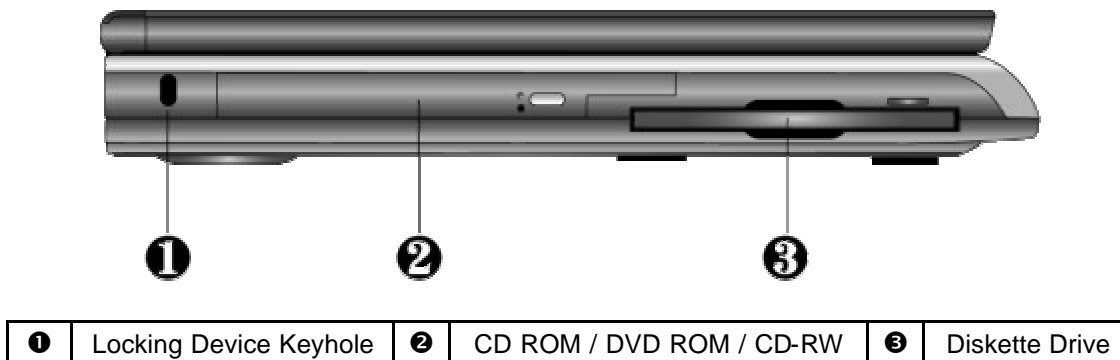

Figure 1-10 Right Side of the Notebook

Locking Device Keyhole

Lets you attach a Kensington security system or a compatible lock to secure your notebook computer.

CD-ROM / DVD-ROM / CD-RW Drive

The notebook comes with a standard 24X+ speed ATAPI IDE CD-ROM drive that supports all major CD formats like CD-R, Photo CD, and Video CD. The drive utilizes a pop-out tray loading mechanism and supports bootable CD by setting the BIOS Setup program. Refer to Chapter 2 of User Manual on how to install the CD-ROM driver. The notebook also comes with the 8X+ speed DVD-ROM drive or 4X+ speed CD-RW driver options.

Floppy Diskette Drive (FDD)

The built-in 3.5 inch FDD allows you to use any standard double-sided high-density (DSHD)

Outline of the A360

diskette for copying and transferring data files. In the BIOS Setup program of the notebook, you also could disable the FDD option or set a password option when accessing the drive.

1.4.5 The Rear Side of the Notebook

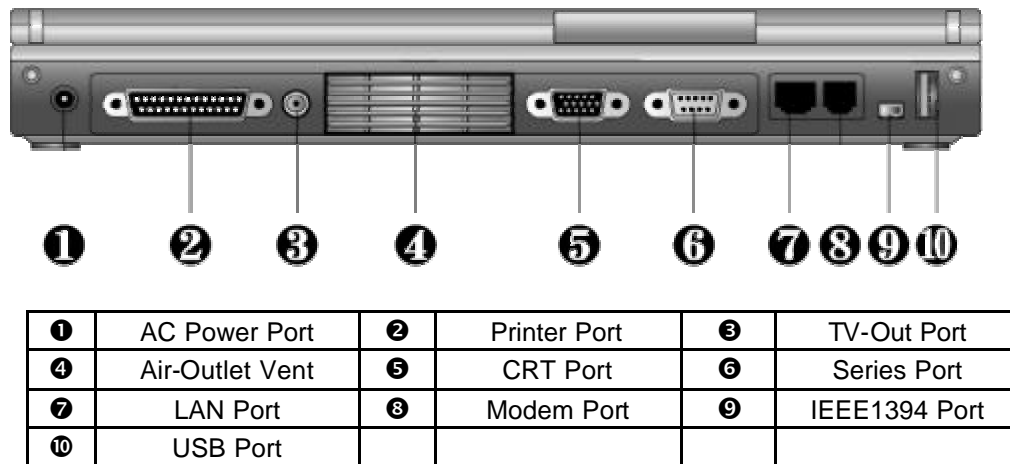

Figure 1-11 Rear Side of the Notebook

AC Power Port

Lets you attach the notebook to the AC power source using the AC adapter that comes with your system. Keep the system connected to AC power whenever possible to keep the battery pack and internal CMOS battery charged. The Battery Charge LED will activate whenever the battery is being recharged.

Printer Port (LPT1)

The printer port lets you connect a 25-pin parallel device such as printer, ZIP drive, or remote data transfer cable. Many operating systems and software applications refer to this port as LPT1. You can run the BIOS setup program to change the configuration of the parallel port to Uni-directional, ECP or EPP mode.

i The default setting for the parallel port on your notebook computer is set to EPP mode. Some parallel devices may not function with the default setting. You need to run the BIOS Setup program to adjust the settings.

TV-Out Port

Lets you connect to a RCA TV connector for presentation or VCD, DVD watching.

Air-Outlet Vent

Emits the heat out of your computer and keeps it within operating temperature.

VGA Port (CRT)

The VGA port lets you connect an external VGA (CRT) monitor to the notebook. You can also run the LCD and the external CRT monitor display simultaneously; or switch it to CRT only using the function hot-key (Fn+F3). When switch to CRT only, you can set the display resolution up to 1280x1024 at 16M colors (32-bit true color).

Outline of the A360

Series Port (COM 1)

The 9-pin serial port provides a serial interface to which you can connect an RS-232C device such as external serial mouse or modem. This port is commonly referred to as COM1.

 When connecting an external serial mouse, you must first power off the system before connecting the external mouse. It can auto-detect the serial mouse hardware and run both glide pad and serial mouse simultaneously.

 Whenever using an external mouse in place of the built-in glide pad, it is recommended to switch the mouse driver to the default standard Microsoft mouse driver.

LAN Port

If you purchase an internal 10Base-T/100Base-TX LAN module, it connects your computer to other computers/networks through a local area network (LAN).

Modem Port

The modem port provides a reserve jack for installing an internal modem with RJ-11 jack. The internal modem is a 56Kbps-fax/data PCI modem and supports the latest V.90 standard and sort of a PCI add-in card reduced into a smaller compact form. The internal module uses mini-PCI technology and is inserted into the mini-PCI socket found on the underside of the notebook. It keeps you connected to the outside world through networks.

IEEE1394 Port

IEEE 1394 port is a high speed I/O port that can transfer high levels of data in real-time, such as external hard disk, Digital Video Camera.

USB (Universal Serial Bus) Ports

The USB (Universal Serial Bus) Port is a port with the symbol . This 4-pin slim port allows you to connect multiple USB devices through daisy chaining or through a USB hub and use them all simultaneously. The USB specification states it can support up to 127 USB devices running at up to 12Mbps. This notebook provides two USB ports.

 When you resume the system from suspend mode, the USB port may not initialize properly. If in case the USB device does not work, unplug and plug the USB device again. This is a known bug released by Intel and Microsoft Windows.

Outline of the A360

1.4.6 The Under Side of the Notebook

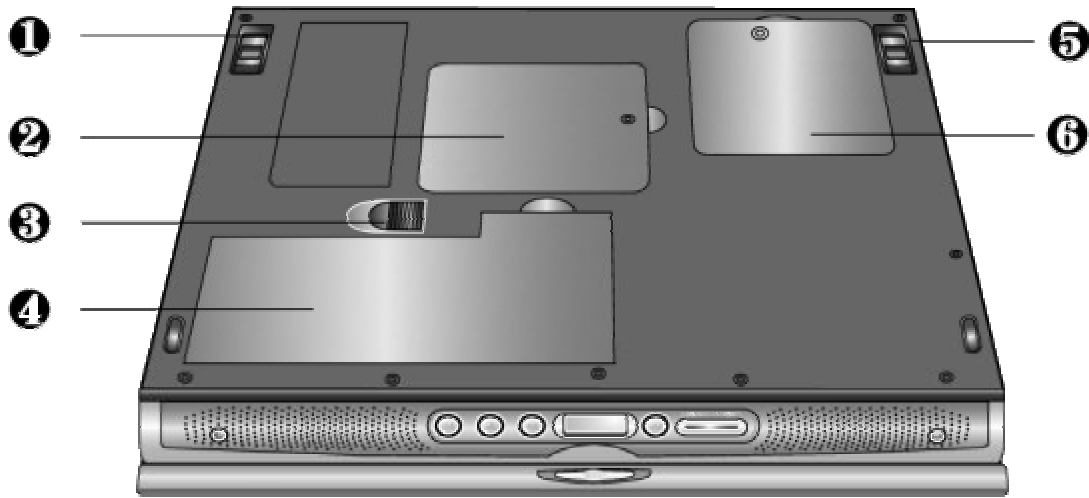

①/⑤	Tilt Foot	②	Memory Compartment
③	Battery Release Latch	④	Battery Bay
⑥	Mini-PCI Socket Compartment		

Figure 1-12 Under Side of the Notebook

Tilt Foot (Left and Right)

Allow you to tilt the rear of the notebook upward to provide flexible keyboard angle for more comfortable typing.

Memory Compartment

Found on the underside of the notebook is the memory compartment. Underneath the cover are two 144-pin SODIMM memory slots for inserting and upgrading the system memory using 64MB, 128MB, or 256MB SODIMM. The notebook uses PC-100/133 SDRAM modules for faster memory access. You can upgrade the total memory up to 512MB. One is inserted with a SDRAM configured by the factory. The other is empty for upgrade use. Refer to Chapter 7 on how to upgrade the system memory.

Battery Release Latch

Also found on the underside of the notebook is the battery bay latch. To remove the battery pack, you need to push this latch to the left end and at the same time pull the battery pack.

Battery Bay

The battery bay stores the Lithium-Ion (Li-Ion) or Nickel Metal-Hydride (NiMH) battery pack for off-the-cord operation. The battery pack is instantly charge whenever you connect the AC adapter to the notebook. It is very important to always have the battery installed on the notebook to have it always charged and conditioned by the AC adapter.

Mini-PCI Socket Compartment

This compartment provides the mini-PCI socket for inserting optional built-in Modem, LAN, or Combo card. Refer to Chapter 2 of User Manual for installing the Modem module.

Outline of the A360

1.5 Notebook Accessories and System Options

It is also important to understand the accessories that come along with the notebook and the options for fully utilizing the capabilities of the computer. This section describes briefly what these accessories and options are.

1.5.1 AC Adapter and Power Cord

The AC Adapter supplies external power to your computer and at the same time charges the internal battery pack. The AC adapter has an auto-switching design that can connect to any 100VAC ~ 240VAC power outlets. Connect the adapter to the AC wall outlet using the power cord. You just change the power cord if you are going to use your notebook in other countries with different connector outlets. When you connect the AC adapter, it charges the battery whether or not the notebook computer is powered on. There is an LED on the AC adapter to indicate if DC power is already available.

1.5.2 Battery Pack

Aside from the AC adapter, your computer can also be powered through the removable battery pack. The battery pack uses rechargeable Nickel Metal-Hydride (NiMH) or Lithium-Ion (Li-Ion) battery cells that can run for 2 to 2.5 hours when fully charged and power management enabled. Recharging the battery takes around 2.5 to 3 hours when the computer is off.

You should always leave the battery inside your computer even when using the AC adapter as it also acts as back-up power supply in case power from the AC adapter is cut off. It is also very important to have the battery pack always charged to prevent battery cell degradation. If the AC adapter is not connected or not available, and the notebook is not going to be used for some period, it is advisable to remove the battery pack from the notebook to prevent any current leak.

1.5.3 Internal Modem Module

The notebook allows you to insert a proprietary internal 56Kbps-modem card to the notebook found on the underside of the notebook. The internal modem card supports only fax and data communication and is V.90-compliant. You connect the telephone line to the RJ-11 jack found on the rear side of the notebook.

1.5.4 Internal Ethernet LAN Module

This notebook comes with an optional 10Base-T/100Base-TX LAN module that supports data transfer rates at 10Mbps and can be up to 100Mbps.

1.5.5 DVD-ROM Drive

Other than the internal CD-ROM drive, the notebook also provides optional factory built-in DVD-ROM drive. DVD-ROM drives are also backward compatible with CD-ROM, so you can also use any audio CDs, video CDs, photo CDs, and CD-R. Using a software MPEG-2/DVD program, the notebook can playback any commercial DVD movie titles.

1.5.6 CD-RW Drive

This device pack can write data to CD-R or CD-RW CD for you to backup the data.

Outline of the A360

1.5.7 Audio-DJ

This notebook comes with optional built-in Audio DJ panel. It can play your Audio CD like the CD player without powering on the whole computer.

1.5.8 Blue Tooth Module

This notebook is ready for Bluetooth technology. This is a wireless connection standard in a short-range radio technology. It aims at simplifying communication between each device with bluetooth module. Bluetooth is in essence a “personal-area network” technology for connecting computers to peripherals and mobile phones.

1.6 System BIOS SETUP Program

The notebook uses the Phoenix BIOS (Basic Input-Output System) Setup program that allows you to set several system configurations in changing the way the system performs. This includes your system time and date, disk drive configuration, I/O device controls, boot drive sequence, and power management settings. The information is then stored in the CMOS RAM chip and will remain permanent unless you change it again. The notebook also uses EPROM Flash BIOS that allows you to update the system BIOS by simply overwriting it using the Phoenix Flash programming utility.

Before boot-up, the system will read the BIOS settings and compare them to the equipment check conducted during the POST (Power-On Self-Test). As the POST (Power-On Self Test) executes during the boot up process or if an error occurs, an error message will be displayed on the screen, the screen will display the following message: "Press <F2> to Enter SETUP". You will then be prompted to run the BIOS Setup Program by pressing the <F2> key to run the BIOS Setup program.

The BIOS Setup program is organized into five menus which you can select using the ← and → keys. To move from one option to another, you use the up and down arrow keys while using the <F5> and <F6>, or <+> and <-> keys to change the settings. On the right hand side of the screen are some brief help descriptions of each item you want to change.

On the BIOS Setup program, you will find the following parts on the screen:

- **Menu Bar** - found on the top line of the screen. Each of the five items has a separate menu screen.
- **Parameters** - found on the left side of the screen. This area lists the parameters and their current settings.
- **Item Specific Help** - found on the right side of the screen. This area describes each parameter and its available settings.
- **Key Status Bar**- the bottom part of the screen. These lines display the keys available to move the cursor, select a particular function and so forth.

To exit the BIOS Setup program, simply press the <Esc> key and select from the Exit menu whether you want to Save changes and exit; Discard Changes and exit.

The following table lists the keys on how to edit and move around the setup menus inside.

Outline of the A360

KEY	WHAT IT DOES
<F1>	Shows on-line help on key functions.
↑ ↓	Moves the cursor between the displayed parameters.
- / +	Modifies the current parameter settings.
<F9>	Load default configuration.
Esc	Exits the current menu and returns to the main menu or go directly to the Exit menu.
← →	Changes between displayed menus.
<Enter>	For some parameter settings, select and moves the cursor between the sub-menu. Also moves the cursor to the next line or selection.
<F10>	Save changes and exit.



Some information here may not be available or different from other date code versions of the notebook BIOS. Always check for the latest BIOS update from the FIC Internet homepage. <ftp://pcg.fic.com.tw/NBTECH>

1.6.1 Using the Main Menu

The BIOS Setup Main Menu contains the settings for system time and date, and disk drives as well as CPU and system memory information.

PhoenixBIOS Setup Utility				
Main	Advanced	Security	Boot	Exit
System Time: [12:00:00] System Date: [01/01/2001] Language: [English (US)] Diskette A: [1.44/1.25 MB 3½"] Internal HDD [20004MB] Internal DVD/CD-ROM Installed Boot Display Device: [Both] System Memory 640 KB Extended Memory 262143 KB CPU Type Pentium® III CPU Speed 1000 MHz BIOS Version 1.0A-0003-3330				Item Specific Help <Tab>, <Shift-Tab>, or <Enter> selects field
F1 Help	↑ ↓	Select Item	- / +	Change Values
Esc Exit	← →	Select Menu	Enter	Select ▶ Sub-Menu
				F9 Setup Defaults
				F10 Save and Exit

Figure 1-13 BIOS Setup Main Menu

Outline of the A360

System Time:	[12:00:00]	<Tab>, <Shift-Tab>, or <Enter> selects field.
System Date:	[01/01/2001]	<Tab>, <Shift-Tab>, or <Enter> selects field.
Language:	[English (US)]	
Diskette A:	[Disabled] / [1.44/1.25MB 3½"]	Select floppy type.
▶ Internal HDD	[10056MB]	
Internal DVD/CD-ROM	Installed / Not installed	(BIOS auto detect, for information only)
Boot Display Device:	[Both] / [CRT] / [LCD]	Choose the display device.
System Memory	640 KB	(BIOS auto detect, for information only)
Extended Memory	262143 KB	(BIOS auto detect, for information only)
CPU Type	Pentium (R) III	(BIOS auto detect, for information only)
CPU Speed	900MHz	(BIOS auto detect, for information only)
BIOS Version	1.0A-0221-0713	(BIOS auto detect, for information only)

- **System Time** – Allows you to change the system time using the hour:minute:second format of the computer. Enter the current time for each field and use the <Tab>, <Shift>+<Tab>, or <Enter> key to move from one field or back to another. You can also change the system time from your operating system.
- **System Date** – This field lets you set the system date using the month/date/year format. Enter the current time for each field and use the <Tab>, <Shift>+<Tab>, or <Enter> key to move from one field or back to another. You can also change the system time from your operating system.
- **Language** – This field allows you to select the display language for the BIOS by the <Tab>, <Shift>+<Tab>, or <Enter> key to move from one field or back to another..
- **Diskette Drive A** – This field allows you to enable or disable the built-in 1.44 3½” Diskette by pressing the <Enter> key.
- **Internal HDD** – This field displays various parameters for the hard disk drive. If type [Auto] is selected, the system automatically sets these parameters. If type [User] is selected, Cylinders, Heads and Sectors can be edited.
- **Internal DVD/CD-ROM** – This field is for information only as the BIOS automatically detects the internal CD-ROM or DVD-ROM Drive.
- **Boot Display Device** – This field allows you to set the output boot display to the LCD, CRT, or Both.
- **System Memory, Extended Memory, CPU Type, CPU Speed and BIOS Version** – These fields are for information only as the BIOS automatically detects related values during Power-On Self-Test (POST).

Outline of the A360

Internal HDD Sub-Menu

PhoenixBIOS Setup Utility		
Main		
Internal HDD [10056MB]	Item Specific Help	
Type:	[Auto]	User = you enter
Cylinders:	[16383]	Parameters of hard-disk
Heads:	[16]	Drive installed at this
Sectors:	[63]	Connection.
Maximum Capacity:	10056MB	Auto = autotypes
Multi-Sector Transfers:	[16 Sectors]	Hard-disk drive
LBA Mode Control:	[Enabled]	Installed here
32 Bit I/O:	[Disabled]	1-39 = you select
Transfer Mode:	[FPIO 4 / DMA 2]	pre-determined type of
SMART Monitoring:	Enabled	hard-disk drive
Ultra DMA Mode:	[Mode 4]	Install here.
		CD-ROM = a CD-ROM drive
		is installed here.
		ATAPI Removable =
		Removable disk drive is
		installed here
F1 Help ↑↓ Select Item -/+ Change Values F9 Setup Defaults Esc Exit ←→ Select Menu Enter Select ▶ Sub-Menu F10 Save and Exit		

Figure 1-14 Internal HDD/CD-ROM Sub-Menu

Type:	[None] / [CD-ROM] / [User] / [Auto]	Select the drive type corresponding to the fixed disk installed in your system. If type USER is selected, Cylinders, Heads & Sectors edited directly.
Cylinders:	[16383]	(BIOS auto detect, for information only)
Heads:	[16]	(BIOS auto detect, for information only)
Sectors:	[63]	(BIOS auto detect, for information only)
Maximum Capacity:	10056MB	(BIOS auto detect, for information only)
Multi-Sector Transfers:	[Disabled] / [2 Sectors] / [4 Sectors] / [8 Sectors] / [16 Sectors]	Determine the number of sectors per block for multiple sector transfers.
LBA Mode Control:	[Disabled] / [Enabled]	Enabling LBA causes Logical Block Addressing to be used in place of Cylinders, Heads & Sectors
32 Bit I/O:	[Disabled] / [Enabled]	This setting enables or disables 32 bit IDE data transfers
Transfer Mode:	[Standard] / [Fast PIO 1] / [Fast PIO 2] / [Fast PIO 3] / [Fast PIO 4] / [FPIO 3 / DMA1] / [FPIO 4 / DMA2]	Select the method for moving data to/from the drive. Autotype the drive to select the optimum transfer mode
SMART Monitoring	[Disabled] / [Enabled]	HDD provides the function of SMART Monitoring
Ultra DMA Mode:	[Mode 1] / [Mode 2]	(BIOS auto detect, for information only)

Outline of the A360

1.6.2 Using the Advanced Menu

The Advanced Menu allows you to configure the OS and I/O device settings.

PhoenixBIOS Setup Utility				
Main	Advanced	Security	Boot	Exit
			Item Specific Help	
PS/2 Mouse			[Enabled]	
LCD Panel View Expansion-			[Enabled]	
Silent Boot:			[Enabled]	
Frame Buffer Size:			[8 Mb]	
▶ I/O Device Configuration				
F1 Help ↑↓ Select Item -/+ Change Values F9 Setup Defaults Esc Exit ↔ Select Menu Enter Select ▶ Sub-Menu F10 Save and Exit				

Figure 1-15 BIOS Setup Advanced Menu

PS/2 Mouse	[Disabled] / [Enabled]	[Disabled] prevents any installed PS/2 mouse from functioning, but frees up IRQ12. [Enabled] allows the operating system to determine whether to enable or disable the mouse.
LCD Panel View Expansion-	[DISABLED] / [ENABLED]	[Disabled] Reduces the panel view in some video mode. [Enabled] Expands the panel view, but it may adversely affect the graphic/text quality
Silent Boot:	[Enabled] / [Disabled] / [Black]	Select boot screen using options: [Enabled] – Logo screen on boot [Disabled] – POST screen on boot [Black] – Black screen on boot
Frame Buffer Size	[None] / [8 Mb] / [16 Mb] / [32 Mb]	Sharing VGA memory size from SDRAM. Recommend you setting the default value to 8MB. If you want to play DVD with Power DVD, please set the size of VGA frame buffer size to 16MB or 32MB and enable Hardware accelerator function under Power DVD.
▶ I/O Device Configuration	Submenu	Peripheral Configuration

- **PS/2 Mouse** – [Disabled] prevents any installed PS/2 mouse from functioning, but frees up IRQ12. [Both] allows both internal and external PS/2 mouse to be active. [Auto] will only allow the external PS/2 mouse to be active if it is detected.

Outline of the A360

- LCD Panel View Expansion-
- **Silent Boot** – Select boot screen during POST.
- **Frame Buffer Size** – Allows you to select sharing VGA memory size from SDRAM. If you want to play DVD with Power DVD, please set the size of VGA frame buffer size to 16MB or 32MB and enable Hardware accelerator function under Power DVD.
- **I/O Device Configuration** – Lets you configure input/output device such as Serial Port, Parallel Port, and Floppy disk controller.

PhoenixBIOS Setup Utility		
Advanced		
I/O Device Configuration	Item Specific Help	
Serial port A:	[Enabled]	Configure serial port using options:
Base I/O address	[3F8 IRQ4]	
Infrared port:	[Enabled]	[Disabled]
Mode:	[IrDA]	No configuration
Base I/O address	[2F8 IRQ3]	
Parallel port:	[Enabled]	[Enabled]
Mode:	[EPP]	User configuration
Base I/O address	[378]	
Floppy disk controller:	[Enabled]	[Auto]
		BIOS or OS chooses configuration
F1 Help ↑↓ Select Item -/+ Change Values F9 Setup Defaults Esc Exit ←→ Select Menu Enter Select ▶ Sub-Menu F10 Save and Exit		

Figure 1-16 I/O Device Configuration Sub-Menu

Serial port A	[Disabled] / [Auto] / [Enabled]	Configure serial port A using options: Disabled - No configuration, Enabled - User configuration, Auto - BIOS or OS configuration.
Base I/O address	[3F8 IRQ4] / [2F8 IRQ3] / [3E8 IRQ4] / [2E8 IRQ3]	Set the base I/O address for serial port A.
Infrared port	[Disabled] / [Auto] / [Enabled]	Configure Infrared port using options: Disabled - No configuration, Enabled - User configuration, Auto - BIOS or OS configuration.
Mode	[IrDA]	Set the mode for Infrared port
Base I/O address	[3F8 IRQ4] / [2F8 IRQ3] / [3E8 IRQ4] / [2E8 IRQ3]	Set the base I/O address for Infrared port.

Outline of the A360

Parallel port	[Disabled] / [Auto] / [Enabled]	Configure parallel port using options: Disabled - No configuration, Enabled - User configuration, Auto - BIOS or OS configuration.
Mode	[ECP] / [EPP] / [Uni-directional]	Set the mode for the parallel port using options: Uni-directional, EPP, and ECP
Base I/O address	[378] / [278] / [178]	Select the base I/O address for the parallel port when port is Enabled.
Floppy disk controller	[Disabled] / [Enabled]	Configure the floppy disk controller using options: Disabled - No configuration, Enabled - User configuration



If you disable a device in BIOS Setup, you cannot enable or assign it using the Windows (98 or 2000) Device Manager. The device is not listed in the Windows device list. You need to select any setting other than "Disable" in Setup.

- **Serial Port A** – You can press <Enter> to select Enabled, Disabled, or Auto option for enabled or disabled this port, or automatically sensed the address assignment by BIOS or OS. When you set the configured parallel port to Enabled rather than Auto, you should also set the parameter of Base I/O address for this port.
- **Infrared Port** – You can press <Enter> to select Enabled, Disabled, or Auto option for enabled or disabled this port, or automatically sensed the address assignment by BIOS or OS. When you set the configured parallel port to Enabled rather than Auto, you should also set the parameter of Base I/O address for this port.
- **Parallel Port** – Allows you to press <Enter> to select the Enabled, Disabled, or Auto option for enabled or disabled this port, or automatically sensed the address assignment by BIOS or OS.
- **Mode** – Allows you to press <Enter> to select a parallel mode as Uni-directional, EPP, or ECP when the parallel port is configured. When you set the configured parallel port to Enabled rather than Auto, you should also set the parameter of Base I/O address for this port.
- **Floppy Disk Controller** – Allows you to press <Enter> to select the Enabled or Disabled option for configured or not configured the floppy disk controller.

Outline of the A360

1.6.3 Using the Security Menu

The Security menu allows you to set the system password as well as disk-protection security.

PhoenixBIOS Setup Utility			
Main	Advanced	Boot	Exit
			Item Specific Help
Set Supervisor Password	[Enter]		Supervisor Password controls access to the setup utility.
Set User Password	[Enter]		
Password on boot:	[Disabled]		
Fixed disk boot sector:	[Normal]		
Diskette access:	[Supervisor]		
F1 Help ↑↓ Select Item -/+ Change Values F9 Setup Defaults Esc Exit → Select Menu Enter Select Sub-Menu F10 Save and Exit			

Figure 1-17 BIOS Setup Security Menu

Set Supervisor Password	Press Enter	Supervisor Password controls access to the setup utility.
Set User Password	Press Enter	User Password controls access to the system.
Password on boot	[Disabled] / [Enabled]	Enabled password entry on boot
Fixed disk boot sector	[Normal] / [Write protect]	Write protects boot sector on hard disk, to protect against viruses.
Diskette access	[User] / [Supervisor]	Control access to diskette drives.

- **Set Supervisor Password** – Specifies if the system prompts you to enter a password when entering Setup.
- **Set User Password** – Specifies if the system prompts you to enter a password when accessing the system. The Set User Password function will be enabled once a Supervisor password is set. Enter a new password with up to eight alphanumeric characters, and then enter this same new password again for confirmation.
- **Password on boot** – Enables password check when booting.
- **Fixed disk boot sector** – [Write Protect] enables write protect boot sector on hard disk to prevent against viruses. [Normal] disables this write protect function.
- **Diskette access** – Controls access to diskette drive.

Outline of the A360

1.6.4 Using the Boot Menu

The Boot menu lets you decide the boot order of booting devices including:

PhoenixBIOS Setup Utility			
Main	Advanced	Security	Exit
+ Removable Devices + Hard Drive ATAPI CD-ROM Drive		Item Specific Help	
		Use <↑> or <↓> to select a device, then press <+> or <-> to move the device up or down. <Enter> expands or Collapses device. <Ctrl+Enter> expands all.	
F1 Help	↑↓ Select Item	-/+ Change Values	F9 Setup Defaults
Esc Exit	←→ Select Menu	Enter Select Sub-Menu	F10 Save and Exit

Figure 1-18 BIOS Setup Boot Menu

- **Removable Devices** – put this option on top if you want to boot from a bootable floppy diskette (Drive A:).
- **Hard Drive** – put this option on top if you want to boot from a bootable hard disk drive (Drive C:).
- **ATAPI CD-ROM Drive** – put this option on top if you want to boot from a bootable CD-ROM like Windows NT /2000 (Drive D:).
- **Network Boot** – put this option on top if you want to boot from LAN network

Outline of the A360

1.6.5 How to Exit the Setup Program

There are three choices to escape from the Setup program.

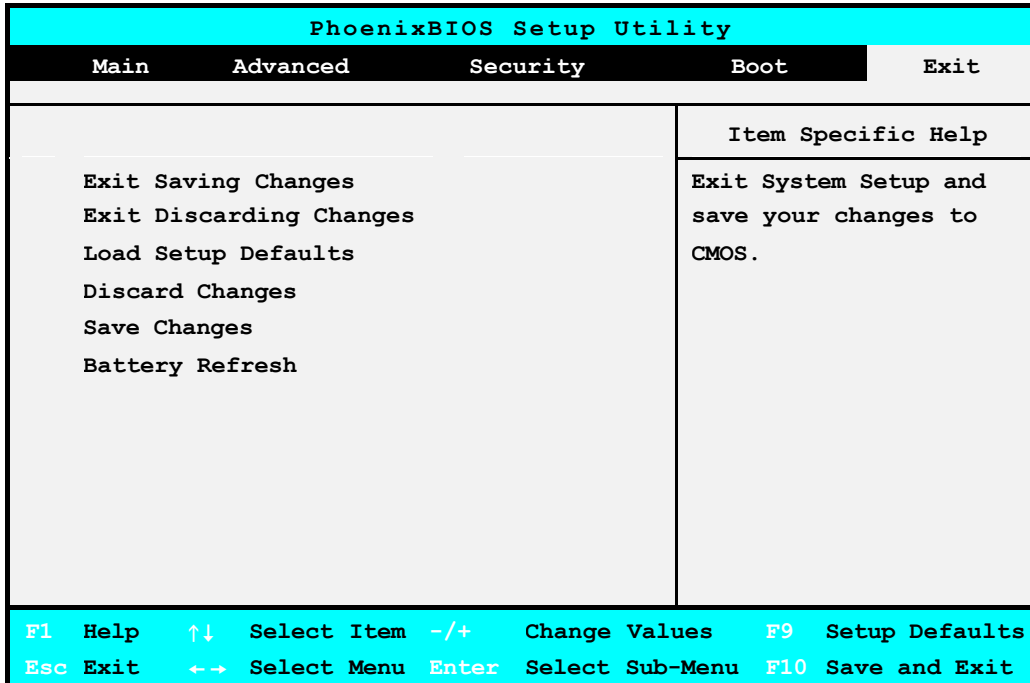

Figure 1-19 BIOS Setup Exit Menu

- **Exit Saving Changes** – Exits System Setup and saves your changes to CMOS.
- **Exit Discard Changes** – Exits Setup utility without saving Setup data to CMOS.
- **Load Setup Defaults** – Loads the default settings for all items in Setup.
- **Discard Changes** – Reverts to previously selected settings.
- **Save Changes** – Saves Setup data to CMOS.
- **Battery Refresh** – Reactivate the battery.