

CSP2600

Engineer	COMPANY NAME	
Drawn by	Address	
REV CTRL	City	
DDC CTRL	TITLE:	Size
MFG BDRG	SGH-E620	
REV	Drawing Number	Sheet 1 of 7
E/C		

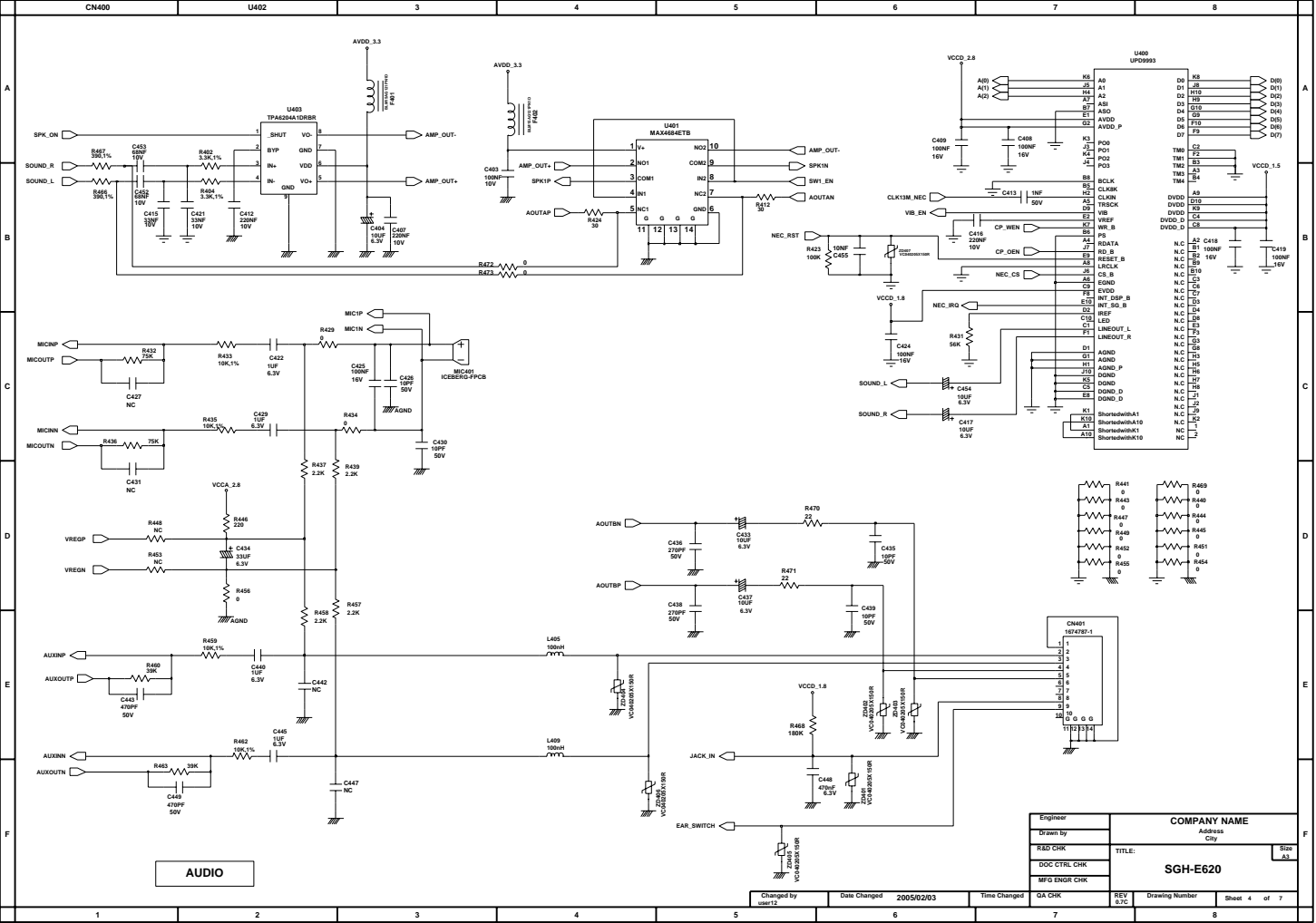

AUDIO

Engineer	COMPANY NAME
Drawn by	Address
RED CHK	City
DWG CTRL CHK	TITLE:
MFG ENGR CHK	SGH-E620
REV 5/12	Drawing Number
Sheet 4 of 7	Size A1

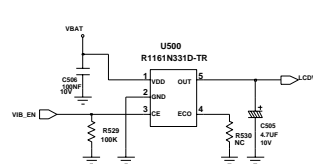
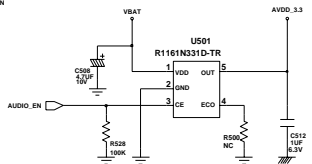
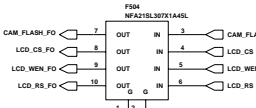
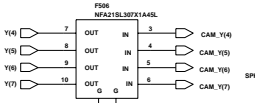
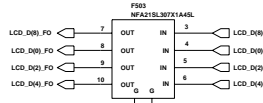
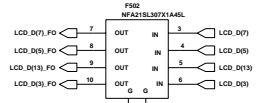
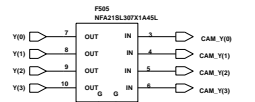
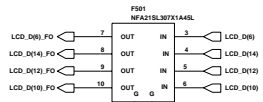
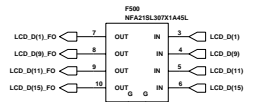

EMI FILTER

AUDIO POWER

VIBRATION

LCD CONNECTOR

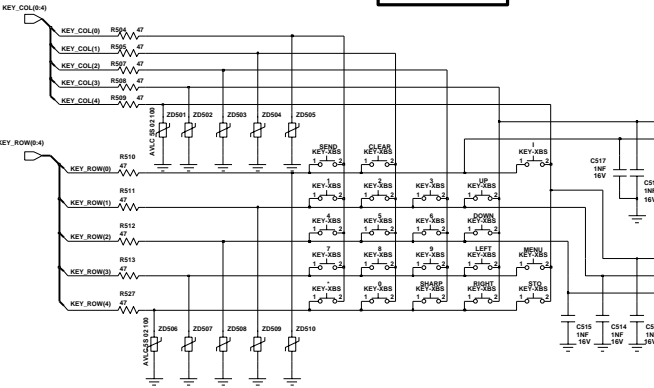

KEY

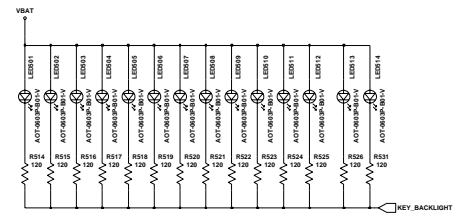

BACK LIGHT LED

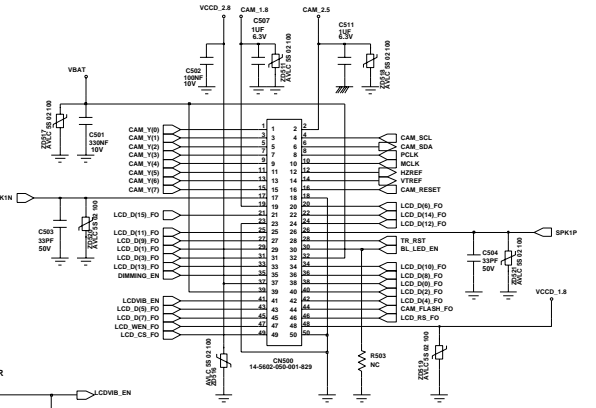

Engineer	COMPANY NAME
Drawn by	Address
RED CHK	City
DISC CTRL CHK	TITLE:
MFG BDRG CHK	SGH-E620
GA CHK	Size
REV	A4
E/C	Sheet 5 of 7

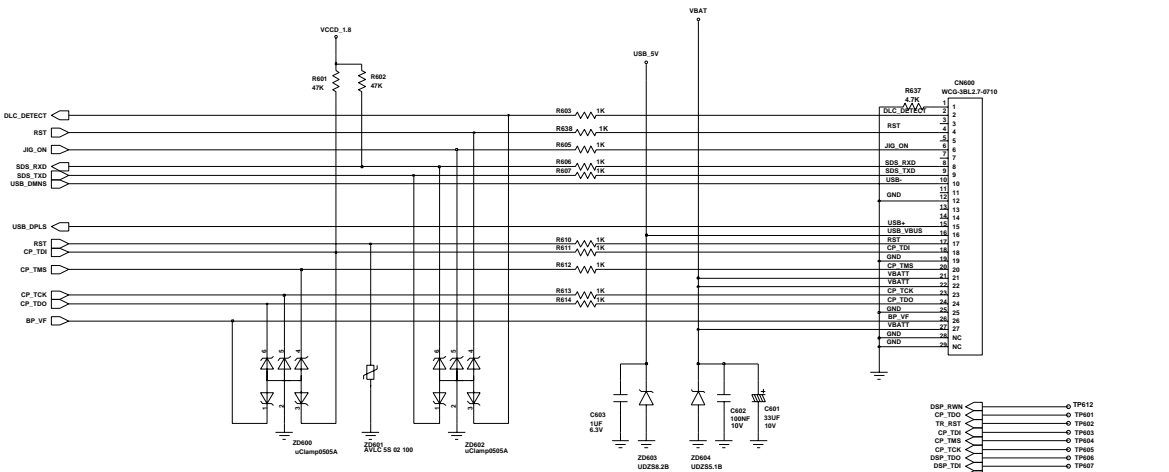

I/F CONNECTOR

JTAG CON

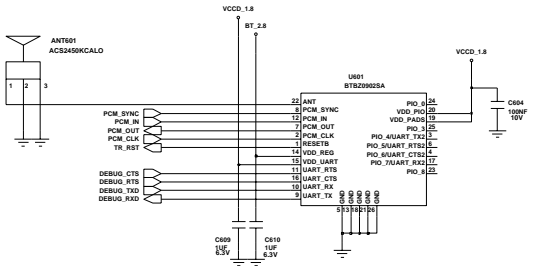
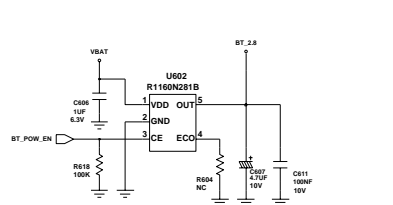

BLUE TOOTH

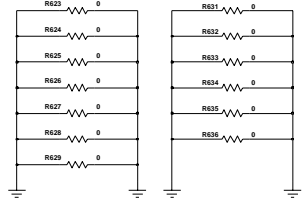

Engineer	COMPANY NAME	
Drawn By	Address	
RED CHK	City	
DOC CTRL CHK	TITLE:	Size A3
MFG ENGR CHK	SGH-E620	
Changed By: user12	Date Changed: 2005/02/03	Time Changed: 9A CHK
REV: 0/3/2	Drawing Number:	Sheet 6 of 7

