iPod shuffle Interface Specification

Release R8



2011-04-04



Apple Inc.
© 2011 Apple Inc.
All rights reserved.

No part of this publication may be reproduced, stored in a retrieval system, or transmitted, in any form or by any means, mechanical, electronic, photocopying, recording, or otherwise, without prior written permission of Apple Inc., with the following exceptions: Any person is hereby authorized to store documentation on a single computer for personal use only and to print copies of documentation for personal use, provided that the documentation contains Apple's copyright notice.

The Apple logo is a trademark of Apple Inc.

Use of the "keyboard" Apple logo (Option-Shift-K) for commercial purposes without the prior written consent of Apple may constitute trademark infringement and unfair competition in violation of federal and state laws.

No licenses, express or implied, are granted with respect to any of the technology described in this document. Apple retains all intellectual property rights associated with the technology described in this document. This document is intended to assist application developers to develop applications only for Apple-labeled computers.

Every effort has been made to ensure that the information in this document is accurate. Apple is not responsible for typographical errors.

Apple Inc.
1 Infinite Loop
Cupertino, CA 95014
408-996-1010

Apple, the Apple logo, iPod, iPod shuffle, and iTunes are trademarks of Apple Inc., registered in the United States and other countries.

Simultaneously published in the United States and Canada.

Even though Apple has reviewed this document, APPLE MAKES NO WARRANTY OR REPRESENTATION, EITHER EXPRESS OR IMPLIED, WITH RESPECT TO THIS DOCUMENT, ITS QUALITY, ACCURACY, MERCHANTABILITY, OR FITNESS FOR A PARTICULAR PURPOSE. AS A RESULT, THIS DOCUMENT IS PROVIDED "AS IS," AND YOU, THE READER, ARE ASSUMING THE ENTIRE RISK AS TO ITS QUALITY AND ACCURACY.

IN NO EVENT WILL APPLE BE LIABLE FOR DIRECT, INDIRECT, SPECIAL, INCIDENTAL, OR CONSEQUENTIAL DAMAGES RESULTING FROM ANY

DEFECT OR INACCURACY IN THIS DOCUMENT, even if advised of the possibility of such damages.

THE WARRANTY AND REMEDIES SET FORTH ABOVE ARE EXCLUSIVE AND IN LIEU OF ALL OTHERS, ORAL OR WRITTEN, EXPRESS OR IMPLIED. No Apple dealer, agent, or employee is authorized to make any modification, extension, or addition to this warranty.

Some states do not allow the exclusion or limitation of implied warranties or liability for incidental or consequential damages, so the above limitation or exclusion may not apply to you. This warranty gives you specific legal rights, and you may also have other rights which vary from state to state.

Contents

Chapter 1 Introduction to iPod shuffle Interface Specification 7

- Notice of Proprietary Property 7
- Scope 7
- Organization of This Document 7
- Specification Terms 8

Chapter 2 1G shuffle Interface Specification 9

- Scope 9
- User and Service Accessibility 9
- Nine-pin USB A Connector 9
 - External Power 10
 - USB 5V Power Connection 11
- Audio Connector 12
 - 1G shuffle Audio Output Specification 12

Chapter 3 2G shuffle Interface Specification 13

- Scope 13
- User and Service Accessibility 13
- Analog Audio/USB Connection 13
 - Analog Audio Output Specification 14
 - External Power 15
 - USB 5V Power Connection 16
- ESD Protection 16
- Connector Protection 17

Chapter 4 3G shuffle Interface Specification 19

- Functional Description 19
- User and Service Accessibility 19
- Analog Audio Connection 19
- Audio Output Specification 20
- 3G shuffle Play Controllers 21
- Charging Accessories 22

Appendix A Charging Accessories for the 3G shuffle 23

- Receiver Chip 23
 - Overview 23
 - Dimensions and Pin Assignments 23

CONTENTS

Maximum Voltage and Current Ratings	25
Recommended Operating Conditions	26
Mode of Operation	26
Receiver Chip External Circuitry	28
Design Certification	29
Signal Line Capacitance	29
Charging Current On and Off	29

Document Revision History 31

Figures and Tables

Chapter 1 Introduction to iPod shuffle Interface Specification 7

Table 1-1 Model numbers and interfaces 7

Chapter 2 1G shuffle Interface Specification 9

Figure 2-1 The 1G iPod shuffle 9
Figure 2-2 1G iPod shuffle connector 10
Figure 2-3 D+ and D- connections for 500mA USB power supply 11
Figure 2-4 D+ and D- connections for 1A USB power supply 11
Figure 2-5 1G audio connector 12
Table 2-1 1G shuffle connector pinout 10
Table 2-2 1G shuffle audio connections 12

Chapter 3 2G shuffle Interface Specification 13

Figure 3-1 The 2G iPod shuffle and dock 13
Figure 3-2 I/O plug for 2G iPod shuffle 14
Figure 3-3 D+ and D- connections for 500mA USB power supply 15
Figure 3-4 D+ and D- connections for 1A USB power supply 15
Figure 3-5 Recommended 2G iPod shuffle dock circuitry 16
Table 3-1 2G shuffle connector pinouts 14

Chapter 4 3G shuffle Interface Specification 19

Figure 4-1 The 3G iPod shuffle 19
Figure 4-2 I/O plug for 3G iPod shuffle 20
Figure 4-3 Play controller circuit 21
Table 4-1 3G shuffle connector pinouts 20
Table 4-2 Play controller circuit components 21

Appendix A Charging Accessories for the 3G shuffle 23

Figure A-1 Receiver chip configuration 24
Figure A-2 Handshake timing 26
Figure A-3 Minimum implementation circuit 28
Table A-1 Receiver chip connections 24
Table A-2 Receiver chip dimensions in millimeters 25
Table A-3 Absolute maximum ratings 25
Table A-4 Recommended operating conditions 26
Table A-5 Electrical characteristics in Mode 1 27

Table A-6	Electrical characteristics in Mode 2	27
Table A-7	Circuit components	28

Introduction to iPod shuffle Interface Specification

Notice of Proprietary Property

THE INFORMATION CONTAINED HEREIN IS THE PROPRIETARY PROPERTY OF APPLE INC. THE POSSESSOR AGREES TO THE FOLLOWING: (I) TO MAINTAIN THIS DOCUMENT IN CONFIDENCE, (II) NOT TO REPRODUCE OR COPY IT, (III) NOT TO REVEAL OR PUBLISH IT IN WHOLE OR IN PART, (IV) ALL RIGHTS RESERVED.

ACCESS TO THIS DOCUMENT AND THE INFORMATION CONTAINED THEREIN IS GOVERNED BY THE TERMS OF THE MFI LICENSE AGREEMENT AND/OR THE IPOD-IPHONE AIS EVALUATION AGREEMENT. ALL OTHER USE SHALL BE AT APPLE'S SOLE DISCRETION.

Scope

This document specifies the electrical and mechanical interfaces to the first, second, and third generations of the iPod shuffle. The shuffle model numbers and interfaces are listed in Table I-1.

Table I-1 Model numbers and interfaces

Name	Model number	Interfaces
1G shuffle	0x0080NNNN, 0x0081NNNN	9-pin USB-compatible connector, 4-pin audio connector
2G shuffle	0x0082NNNN	4-pin input/output connector to dock
3G shuffle	0x0083NNNN	4-pin input/output connector to cable

Organization of This Document

The technical content of this document is presented in three chapters and one appendix:

- [1G shuffle Interface Specification](#) (page 9) specifies the interfaces to the iPod 1G shuffle.
- [2G shuffle Interface Specification](#) (page 13) specifies the interfaces to the iPod 2G shuffle.
- [3G shuffle Interface Specification](#) (page 19) specifies the interfaces to the iPod 3G shuffle.
- [Charging Accessories for the 3G shuffle](#) (page 23) specifies the electrical requirements for accessories that provide charging current to the iPod 3G shuffle.

Specification Terms

Parts of this document contain specification requirements that are incorporated by reference into legal agreements between Apple Inc. and its licensees. The use of the words “must” and “should” in these specifications have the following meanings:

- “Must” means that the specification is an absolute requirement.
- “Must not” means that the specification is an absolute prohibition.
- “Should” means that there may be valid reasons in particular circumstances to ignore the specification, but their full implications must be understood and carefully weighed before choosing to do so.
- “Should not” means that there may be valid reasons in particular circumstances that make the specified action or feature acceptable, but their full implications must be understood and carefully weighed before choosing to include it.

1G shuffle Interface Specification

Scope

This chapter specifies the electrical interfaces for both the top headphone jack (top) and the 9-pin USB A (bottom) connectors on the first generation (1G) iPod shuffle (see [Figure 2-1](#) (page 9)). An external device may charge the iPod shuffle and accept its audio output when it is playing. However, it is not possible for an external device to communicate with or control the 1G iPod shuffle.

Figure 2-1 The 1G iPod shuffle



User and Service Accessibility

There are no user serviceable items in the 1G iPod shuffle. Its enclosure is not designed to be opened.

Nine-pin USB A Connector

The 9-pin iPod 1G shuffle connector is compatible with a standard (4-pin) USB A connector. Five additional pins have been added, as shown in [Figure 2-2](#) (page 10). The additional pins provide left and right audio channels and audio return; two pins are reserved for future use.

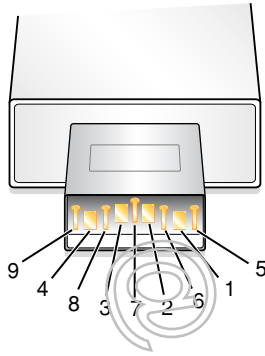
Figure 2-2 1G iPod shuffle connector

The pin numbering of the 1G iPod shuffle's 9-pin connector, from left to right, is 9-4-8-3-7-2-6-1-5. Pin assignments are shown in [Table 2-1](#) (page 10).

Table 2-1 1G shuffle connector pinout

Pin	Signal name	Function
1	USB 5V	USB power to iPod
2	USB D-	USB signal
3	USB D+	USB signal
4	GND	USB and charger ground
5	Reserved for future use	No connection
6	Reserved for future use	No connection
7	HP_COMMON	Headphone audio return (do not ground in accessory)
8	HP_L	Headphone audio output, left channel
9	HP_R	Headphone audio output, right channel

External Power

The 9-pin connector interface to the 1G iPod shuffle is designed to function as a Hi-Speed USB device compliant with the USB Mass Storage Class specification. If a device is to power the shuffle, and it does not communicate with the shuffle using the USB data pins (or pass through those pins, as in a dock), D+ and D- should be connected in the device as shown in [Figure 2-3](#) (page 11) or [Figure 2-4](#).

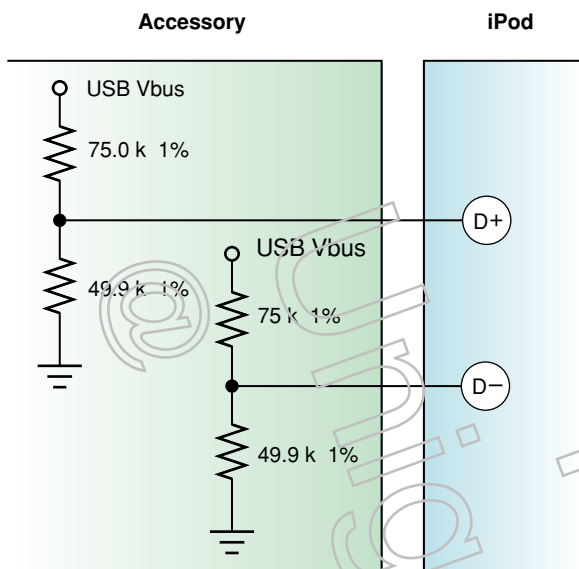
Figure 2-3 D+ and D- connections for 500mA USB power supply

If the device can source 1 A (maximum), connect the D+ and D- pins as shown in Figure 2-4.

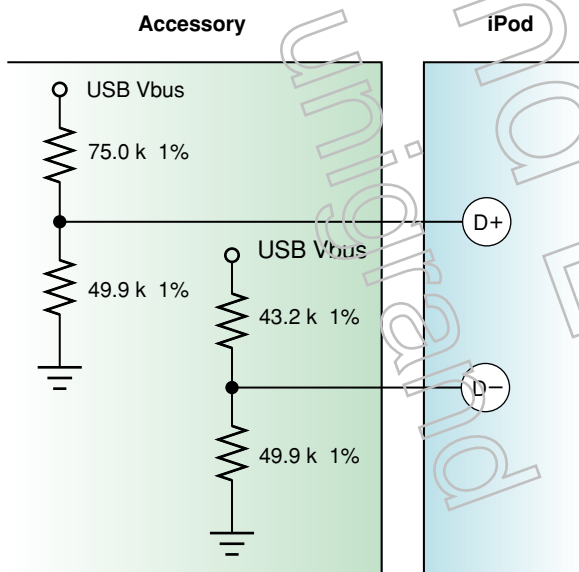
Figure 2-4 D+ and D- connections for 1A USB power supply

USB 5V Power Connection

The nominal +5V power source of the accessory device should be USB Vbus power. For more information about USB power, see the USB Implementers Forum's [Universal Serial Bus](#) website.

USB power supplies are required to use appropriate resistors as shown in Figure 2-3 and Figure 2-4. The iPod needs these resistors to determine how current is supplied. To prevent electrical problems, some iPod models will not charge if the attached power supply lacks these resistors.



Audio Connector

Figure 2-5 shows the audio (headphone) plug and pin assignments for use as an audio connector with the 1G iPod shuffle.

Figure 2-5 1G audio connector

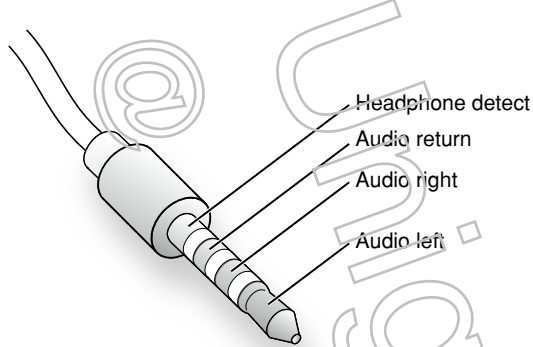

Pin connections through the 1G iPod shuffle's audio connector are shown in [Table 2-2](#) (page 12).

Table 2-2 1G shuffle audio connections

Signal name	Function
HP_L	Headphone audio output, left channel
HP_R	Headphone audio output, right channel
HP_COMMON	Headphone audio return (do not ground in accessory)
HP_DETECT	Used by iPod to detect presence of headphones

1G shuffle Audio Output Specification

The audio output of the 1G iPod shuffle conforms to these specifications:

- Stereo output, ~10 mW per channel when driven into a 32 ohm load.
- Direct-drive (DC-coupled).
- Audio voltage rail varies from 1.4 V to 1.7 V (volume dependent).
- Output volume controlled by iPod.
- Audio is available simultaneously from the 9-pin USB A and Audio connectors.

2G shuffle Interface Specification

Scope

This chapter specifies the electrical interface for the 4-pin connector on the second generation (2G) iPod shuffle (see [Figure 3-1](#) (page 13)). An external device may either charge the iPod shuffle or accept its audio output when it is playing; it cannot do both at the same time. It is not possible for an external device to communicate with or control the 2G iPod shuffle.

WARNING: To avoid damaging other equipment, designers of external devices that plug into the 2G iPod shuffle must be aware of the cautions in this specification. See [“ESD Protection”](#) (page 16) and [“Connector Protection”](#) (page 17).

Figure 3-1 The 2G iPod shuffle and dock

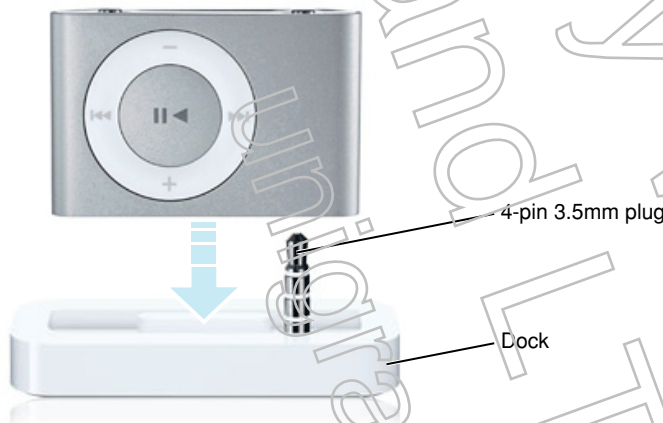

User and Service Accessibility

There are no user serviceable items in the 2G iPod shuffle. Its enclosure is not designed to be opened.

Analog Audio/USB Connection

The 2G iPod shuffle 4-pin I/O jack is designed to accept a 3.5 mm stereo headphone plug. The jack functions as a single hardware interface to both the analog audio output function and the USB function, but only one of these functions can be active at any time.

Warning: Accessories that provide a power connection or USB connection through the I/O jack must be designed to prevent damage to other electronic devices. See “ESD Protection” (page 16) for important information.

The contacts (pins) of the I/O jack and their signal assignments are listed in [Table 3-1](#) (page 14).

Table 3-1 2G shuffle connector pinouts

Pin	Audio signal	Audio function	USB signal	USB function
1	HP_L	Headphone audio output, left channel	USB D-	USB data signal
2	HP_R	Headphone audio output, right channel	USB D+	USB data signal
3	HP_COMMON	Headphone audio return. Do not ground in accessory.	GND	USB and charger ground
4	N/A		USB 5V	USB power to iPod

The USB function of the 2G iPod/iPod shuffle is compliant with the USB Mass Storage Class specification for a Hi-Speed USB device.

[Figure 3-2](#) (page 14) shows the pin numbering for a plug compatible with the iPod shuffle I/O jack.

Figure 3-2 I/O plug for 2G iPod shuffle

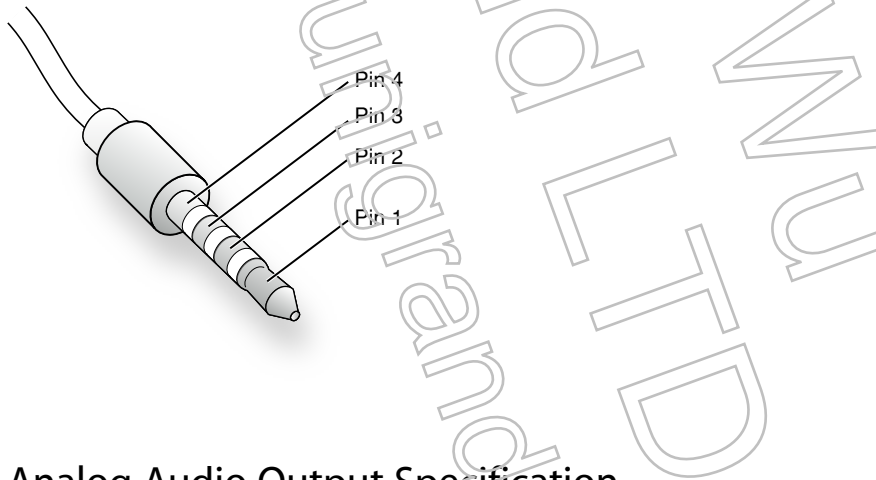

Analog Audio Output Specification

The analog audio output of the 2G iPod shuffle conforms to these specifications:

- Stereo output, ~12 mW rms per channel when driven into a 30 Ω load.
- AC-coupled.
- Output voltage (0 dBFS): nominally -4.5 dBV into 30 Ω (600 mV rms, 1.7 V pp).
- Output volume is controlled by the iPod.
- Analog audio output is not available while the iPod is in USB mode.

External Power

If a device is to power the shuffle but does not communicate with the shuffle using the USB data signals or pass those signals through (as in the case of a dock), D+ and D- should be connected in the device as shown in [Figure 3-3](#) (page 15) or [Figure 3-4](#) (page 15).

Figure 3-3 D+ and D- connections for 500mA USB power supply

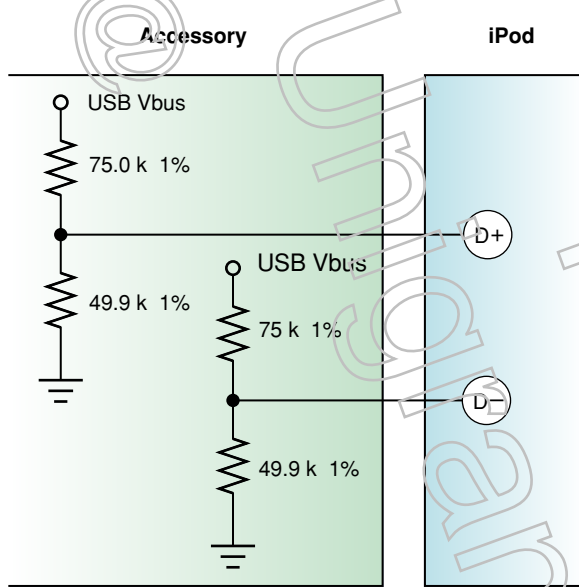

If the device can source 1 A (maximum), connect the D+ and D- pins as shown in [Figure 3-4](#) (page 15).

Figure 3-4 D+ and D- connections for 1A USB power supply

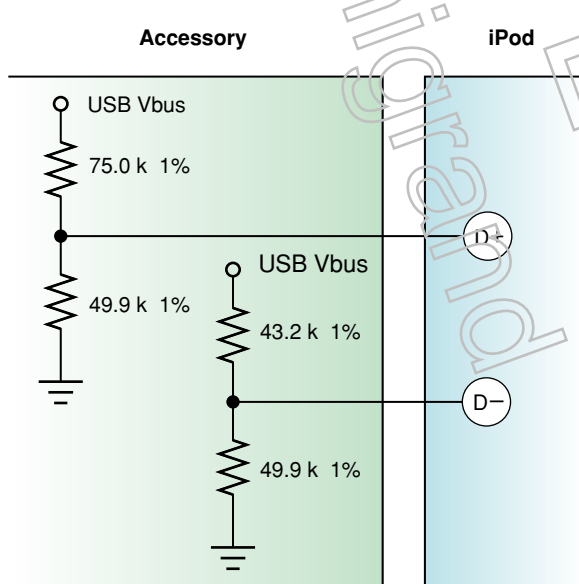

USB 5V Power Connection

The nominal +5V power source of the accessory device should be USB Vbus power. For more information about USB power, see the USB Implementers' Forum's [Universal Serial Bus](#) website.

USB power supplies are required to use appropriate resistors as shown in [Figure 3-3](#) (page 15) or [Figure 3-4](#) (page 15). The iPod needs these resistors to determine how current is supplied. To prevent electrical problems, some iPod models will not charge if the attached power supply lacks these resistors.

ESD Protection

Accessories that provide a power connection or USB connection through the I/O jack must be designed to prevent damage to other electronic devices. The plug on these accessories is normally unshielded. This means that when it is not plugged into the shuffle it may pick up an electrostatic discharge (ESD) from the environment. Such a discharge could damage other equipment, such as a computer connected to the plug.

The dock that Apple ships with each 2G iPod shuffle contains ESD protection circuitry designed to minimize this risk. The schematic diagram in [Figure 3-5](#) (page 16) show example circuitry recommended to avoid ESD problems in accessory devices.

Figure 3-5 Recommended 2G iPod shuffle dock circuitry

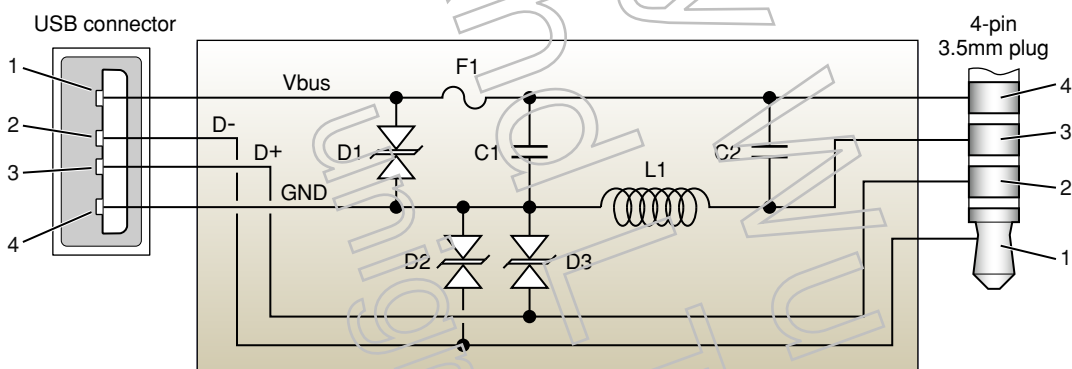

F1	1.1 A resettable fuse; Littlefuse 1206L110 recommended
D1	100 pF ESD Suppressor; Amotech Electronics AVL5C 5M 02 100 or TDK AVR-M1005C080MTABB recommended
D2, D3	0.25 pF ESD suppressor; Tyco Electronics PESD0402-060 recommended
C1	0.01 μ F ceramic capacitor, 10%, 16 V, X7R
C2	10 μ F ceramic capacitor 10%, 16 V, X5R
L1	0.25 Ω (DC) ferrite bead; Murata Corporation BLM18EG601SN1 recommended

Fuse F1 (in [Figure 3-5](#) (page 16)) protects the host computer in the event of a short between the power (Vbus) and ground (GND) pins when an iPod shuffle is not connected to the dock. ESD suppressors D1, D2, and D3 prevent damage to a host computer when the dock plug is exposed; note that D2 and D3 have lower capacitance than D1 to prevent degradation of the 480 Mbps USB D+ and D- signals. Capacitor C1 and ferrite L1 reduce radiated emissions from the iPod shuffle and the dock. Capacitor C2 preserves USB stability during an ESD event.

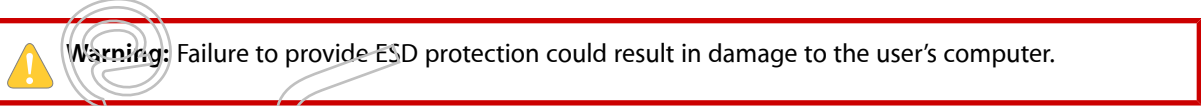

Connector Protection

The dock from Apple is keyed to the 2G iPod shuffle; that is, it features molded ridges that physically prevent its connection to any iPod other than a 2G shuffle, thus preventing inadvertent damage from contact with the USB power pin.

Designers of external devices intended to plug into the 2G shuffle should adopt similar safeguards to prevent the device from being connected to a different iPod model. The [2G iPod shuffle dimensional drawing](#) may be helpful in this regard.



Unigraund
Party
MNU
LTD
unigraund

3G shuffle Interface Specification

This chapter specifies the electrical interface for the 4-pin connector on the third generation (3G) iPod shuffle (see Figure 4-1, below).

Functional Description

The 3G iPod shuffle is charged through the same Apple-supplied USB cable that connects it to the user's computer and iTunes library. An accessory cannot charge the 3G shuffle. Charging it and synchronizing it to the user's computer is accomplished only by Apple proprietary technology.

An external accessory can accept the shuffle's audio output when it is playing, and it can control the 3G shuffle's playback volume by means of the remote button system described in Appendix C, "Headphone Remote and Mic System" in *iPod Accessory Protocol Interface Specification*.

Figure 4-1 The 3G iPod shuffle

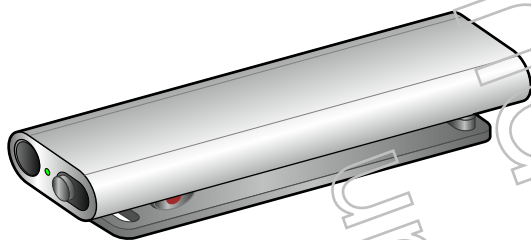

User and Service Accessibility

There are no user serviceable items in the 3G iPod shuffle. Its enclosure is not designed to be opened.

Analog Audio Connection

The 3G iPod shuffle 4-pin I/O jack is designed to accept a 3.5 mm stereo headphone plug. The jack functions as a single hardware interface to both the analog audio output function and the headphone remote and mic system. The plug and its pin numbering are shown in Figure 4-2. The contacts (pins) of the I/O jack and their signal assignments are listed in Table 4-1.

Figure 4-2 I/O plug for 3G iPod shuffle

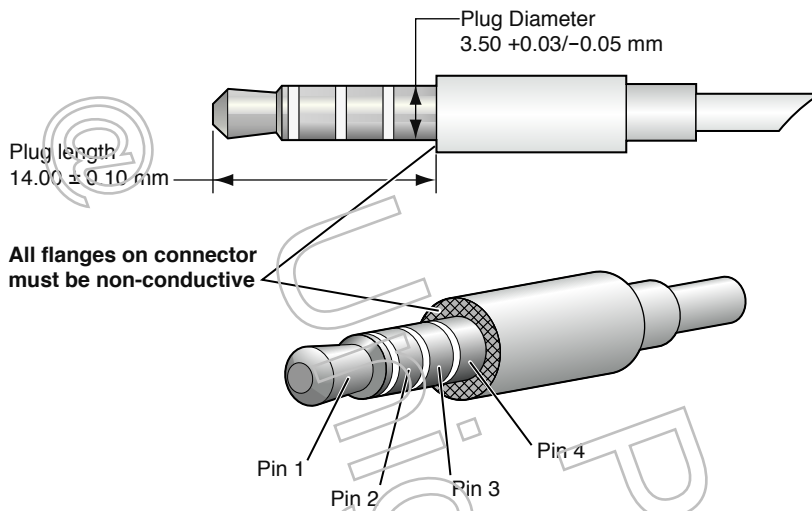

Dimensions of the iPod 3G shuffle's I/O plug not shown in Figure 4-2 must be compatible with Electronic Industries Association of Japan specification EIAJ RC 5325A.

WARNING: The outermost shell (hand grip) shown in Figure 4-2, **including its face**, must be made of nonconductive material.

Table 4-1 3G shuffle connector pinouts

Pin	Signal	Function
1	HP_L	Headphone audio output, left channel
2	HP_R	Headphone audio output, right channel
3	HP_COMMON	Headphone audio return. Do not ground in accessory.
4	REMOTE	Playback control line (see below).

All headphone accessories designed to the specification in *iPod Accessory Protocol Interface Specification* Appendix C, "Headphone Remote and Mic System," provide remote control of the shuffle's playback and volume through pin 4 of its connector. The control current must be between 210 and 500 μ A, measured into a circuit pulled up to 2.7 V through 2.21 k Ω . If the accessory has a microphone, the shuffle ignores it.

Audio Output Specification

The analog audio output of the 3G iPod shuffle conforms to these specifications:

- AC-coupled stereo output, ~12 mW rms per channel when driven into a 30 Ω load.
- Output voltage (0 dBFS): nominally -4.5 dBV into 30 Ω (600 mV rms, 1.7 V pp).

3G shuffle Play Controllers

Third-party developers may develop play controllers for the iPod 3G shuffle. These accessories must plug into the 3G shuffle, using the plug specified in [Analog Audio Connection](#) (page 19), and must provide as their audio output a 3-pin-only jack or 3-pin-only plug for other listening equipment. The play controller's internal circuitry must be as shown in Figure 4-3.

Figure 4-3 Play controller circuit

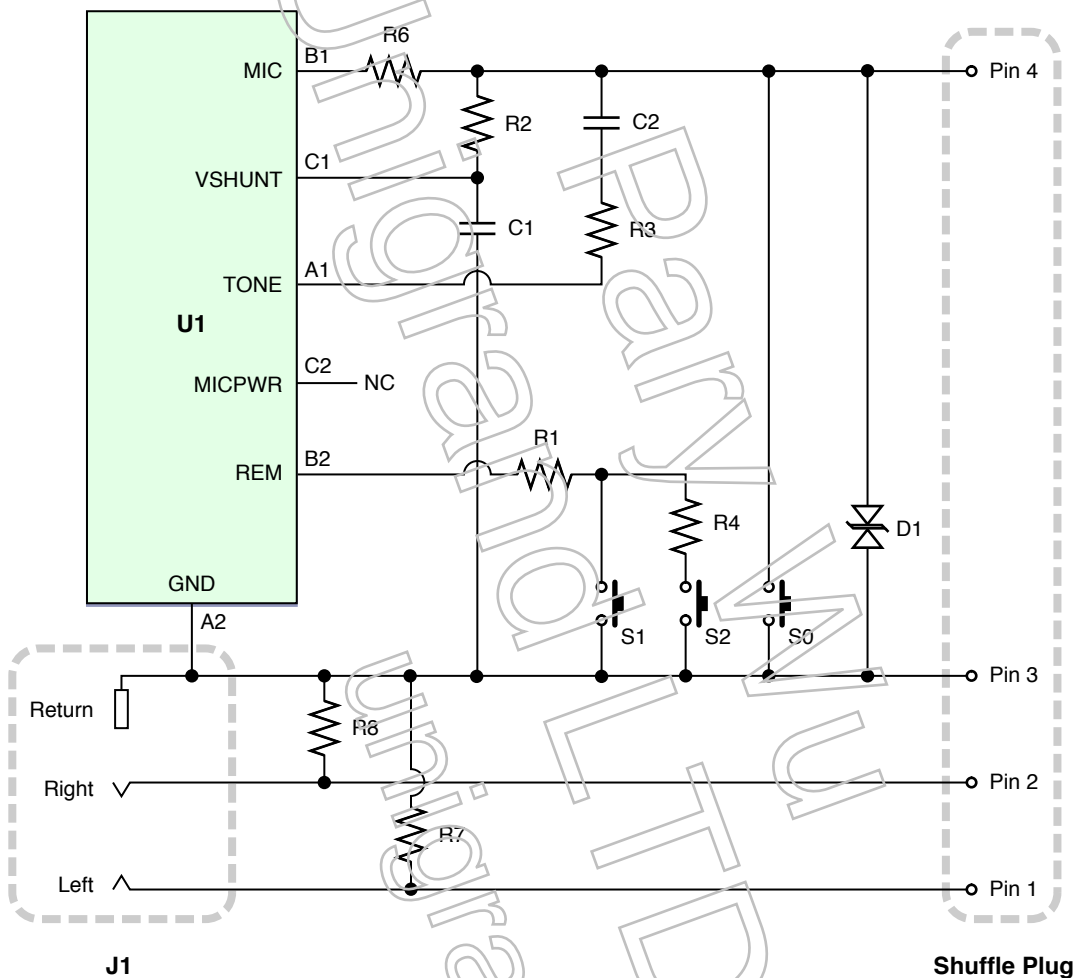

The values of the components shown in [Figure 4-3](#) (page 21) must be those listed in [Table 4-2](#).

Table 4-2 Play controller circuit components

Symbol	Description	Notes
C1	Capacitor, 0.1 μF $\pm 10\%$, 6.3 V	Ceramic
C2	Capacitor, 220 pF $\pm 5\%$, 25 V	Ceramic

Symbol	Description	Notes
D1	ESD protection diode, 5 pF, 6.1 V	ST Micro ESDALC6V1-1BU2; install as close to chip pin B1 as possible
J1	3-conductor audio jack or plug	The detect connection is not used. To minimize crosstalk, the signal return between J1 and the shuffle plug must use a separate conductor.
R1	Resistor, 6.81 k Ω \pm 0.5%, 1/20 W	
R2	Resistor, 6.81 k Ω \pm 1%, 1/20 W	
R3	Resistor, 6.81 k Ω \pm 1%, 1/20 W	
R4	Resistor, 2.61 k Ω \pm 0.5%, 1/20 W	
R6	Resistor, 49.9 Ω \pm 1%, 1/20 W	
R7	Resistor, 100 Ω \pm 5%, 1/20 W	Required to minimize a potentially damaging low-impedance 2.7 V "pop" while the shuffle connector is being inserted or extracted.
R8	Resistor, 100 Ω \pm 5%, 1/20 W	
S0	Dome switch	Play/pause, next/previous track, voice-over
S1	Dome switch	Volume down
S2	Dome switch	Volume up
U1	Headset interface transmitter chip	Provided by Apple.

Charging Accessories

Third-party developers may provide charging accessories for the 3G iPod shuffle that use the connector specified in [Analog Audio Connection](#) (page 19). The electrical requirements for such accessories are specified in [Charging Accessories for the 3G shuffle](#) (page 23).

Charging Accessories for the 3G shuffle



The technology defined in this appendix supports the design of accessories that charge the iPod 3G shuffle through its headphone jack.

Every charging accessory for the 3G shuffle must contain a receiver chip provided by Apple. The receiver chip negotiates with a transmitter chip inside the shuffle. It turns on the 5 V charging current only when the shuffle sends it a message indicating that it is safe to do so. This prevents the accessory's plug from shorting out when it is not inserted, and from delivering damaging current if it is inadvertently inserted into a device other than the 3G shuffle.

Note: Charging accessories that use this technology must be tested and certified. The required tests are specified in [“Design Certification”](#) (page 29).

This appendix specifies the receiver chip and its required external circuitry that must be included in the charging accessory. The corresponding transmitter functionality is implemented inside the iPod 3G shuffle. The plug that the accessory must use to connect to the shuffle is specified in [“Analog Audio Connection”](#) (page 19).

Receiver Chip

This section describes the charging accessory's receiver chip. The minimum external circuitry required to implement the receiver is described in [“Receiver Chip External Circuitry”](#) (page 28).

Note: The receiver chip must be obtained from Apple, referencing part number MFI338S0530.

Overview

The receiver chip is a custom integrated circuit in a QFN (RSE) package that negotiates with a circuit inside the shuffle to open a USB V_{BUS} connection into the shuffle for a nominal +5 VDC charging current up to 200 mA. The chip operates in two modes, Mode 1 and Mode 2. In Mode 1, only a low-voltage low-current signal is passed to the shuffle. After the current-signaling handshake between the shuffle and the receiver chip, the chip switches to Mode 2, where full charging current is switched on. When the accessory is disconnected from the shuffle, the chip reverts to Mode 1 within 240 ms.

Dimensions and Pin Assignments

[Figure A-1](#) (page 24) shows the configuration of the receiver chip and its pad locations. [Table A-1](#) (page 24) identifies the electrical connections to the receiver chip. [Table A-2](#) (page 25) lists the chip's dimensions in millimeters.

Figure A-1 Receiver chip configuration

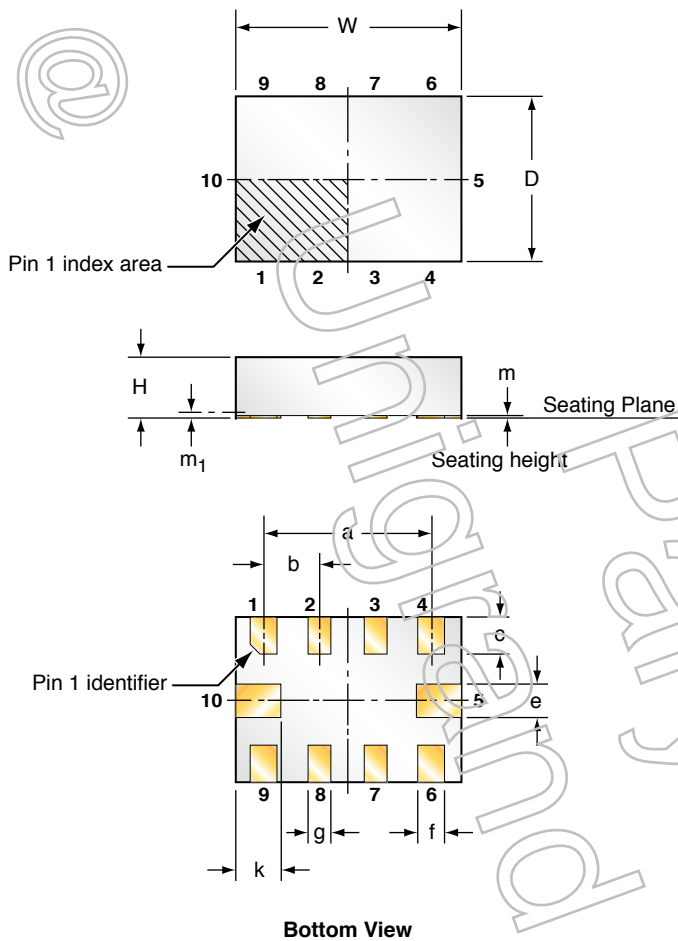

Table A-1 Receiver chip connections

Pads	Name	Description
1, 2, 3	V_{CC}/IN	Supply voltage / USB V_{BUS} input voltage
4, 5	GND	Ground
6	EXTCAP	External capacitor
7, 8, 9	OUT	Protected V_{BUS} output voltage
10	NPG	Negative protection gate

Table A-2 Receiver chip dimensions in millimeters

Symbol (Figure A-1)	Maximum	Nominal	Minimum
W	2.05		1.95
D	1.55		1.45
H	0.60		0.50
m ₁		0.05 radius	
m	0.05		0.00
a		1.50	
b		0.50	
c	0.40		0.30
Pin 1 identifier		0.10 at 45°	
e	0.35		0.25
f	0.30		0.20
g	0.25		0.15
k	0.45		0.35

Maximum Voltage and Current Ratings

Table A-3 (page 25) gives the receiver chip's maximum allowable values for supply voltage, input current, storage temperature, and electrostatic discharge. Exceeding these values may cause permanent damage to the chip.

Table A-3 Absolute maximum ratings

Name	Description		Maximum value
V _{CC}	Supply voltage range		- 0.3 V to 16 V
I _{IN}	Input current		0.5 A
T _{stg}	Storage temperature range		- 65° C to 150° C
ESD	Electrostatic discharge	Human-body model (IEC61340-3-1:2002 Level 2)	2000 V
		Charged-device model (JESD22-C101-A Level III)	500 V

Recommended Operating Conditions

Table A-4 (page 26) lists the receiver chip's recommended operating conditions.

Table A-4 Recommended operating conditions

Name	Description	Minimum	Typical	Maximum	Unit
V _{CC}	Supply voltage	4.25	5	5.5	V
T _A	Operating free-air temperature	0		70	°C

Mode of Operation

Figure A-2 (page 26) shows the timing of the negotiation between the receiver chip and the shuffle. This timing assumes that USB V_{BUS} +5 V is connected to the chip before the chip's implementation circuit is connected to the shuffle.

Note: Voltage, current and timing values may vary and are provided for reference only.

Figure A-2 Handshake timing

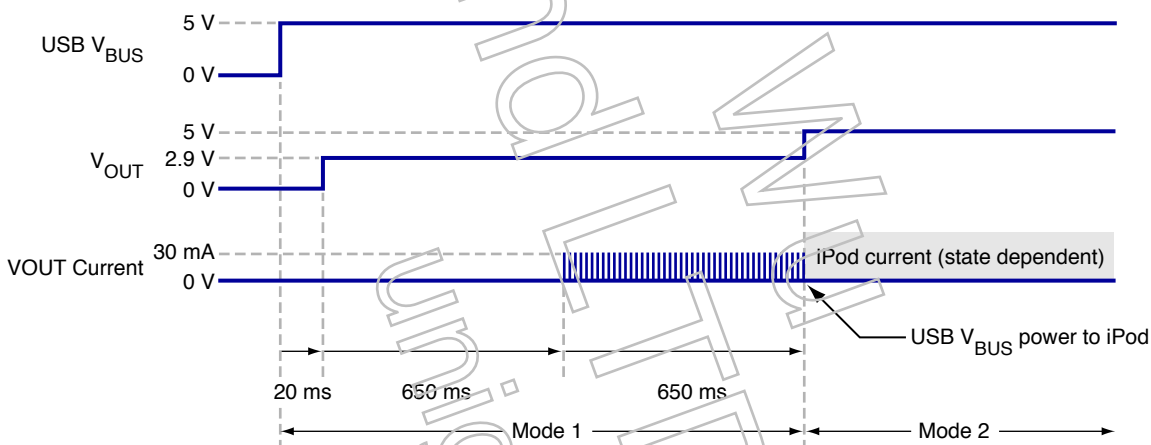

As shown in Figure A-2, the accessory provides 2.9 V to the shuffle plug 20 ms after full 5 V USB power is applied to it. The current output at that stage is limited to 20 mA. 650 ms later the shuffle begins to send a pulse code to the accessory, which continues for another 650 ms. After verifying the pulse code, the receiver chip in the accessory switches on the full 5 V charging current to the shuffle through its audio connector.

Table A-5 (page 27) lists the receiver chip's electrical characteristics in Mode 1, before it has negotiated with the transmitter in the iPod 3G shuffle. Table A-6 (page 27) shows the chip's DC characteristics in Mode 2, after a successful negotiation, when it is ready to supply charging power to the shuffle.

The values in both tables are valid over the chip's free-air temperature range of 0° to 70° C.

Table A-5 Electrical characteristics in Mode 1

Name	Parameter	Test conditions	Minimum	Typical	Maximum	Unit
DC specifications						
OVP	Overvoltage protection trip point		5.5		6	V
OVP _{hys}	Overvoltage protection trip point hysteresis	V _{IN} = 0 V □ 6 V, 16 V □ V		60		mV
I _{CC}	Supply current	No load, V _{CC} = 5.25 V		100	130	μA
V _O	Activation voltage	OUTPUT, I _{LOAD} = 5 mA	2.7		3.1	V
I _{O(max)}	Current limit	Output shorted to GND, V _{CC} = 5.25 V	4		20	mA
AC specifications						
t _{valid}	Startup delay time	From V _{CC} valid to OUTPUT ≥ 2.7 V		20		ms
t _{dis(OVP)}	OVP disable time	INPUT = 5.5 V to 16 V		0.40		ms
t _{ms}	Mode switch time	Current pulse to mode switch	0.150	0.5	0.800	s

Table A-6 Electrical characteristics in Mode 2

Name	Parameter	Test conditions	Minimum	Typical	Maximum	Unit
OVP	Overvoltage protection trip point		5.5		6	V
OVP _{hys}	Overvoltage protection trip point hysteresis	V _{IN} = 0 V □ 6 V, 16 V □ V		60		mV
I _{CC}	Supply current (I _{IN} -I _{OUT})	V _{CC} = 5.25 V		100	160	μA
R _{on}	On resistance	I _{OUT} = 200 mA, V _{CC} = 5.0 V		150	300	mΩ
t _{ms}	Mode switch time	Current pulse removal to mode switch		240		ms
t _{slew}	Slew rate, gate of pass transistor			100		V/ns

Receiver Chip External Circuitry

Figure A-3 (page 28) shows the minimum circuit required in a charging accessory to support the required receiver chip.

Figure A-3 Minimum implementation circuit

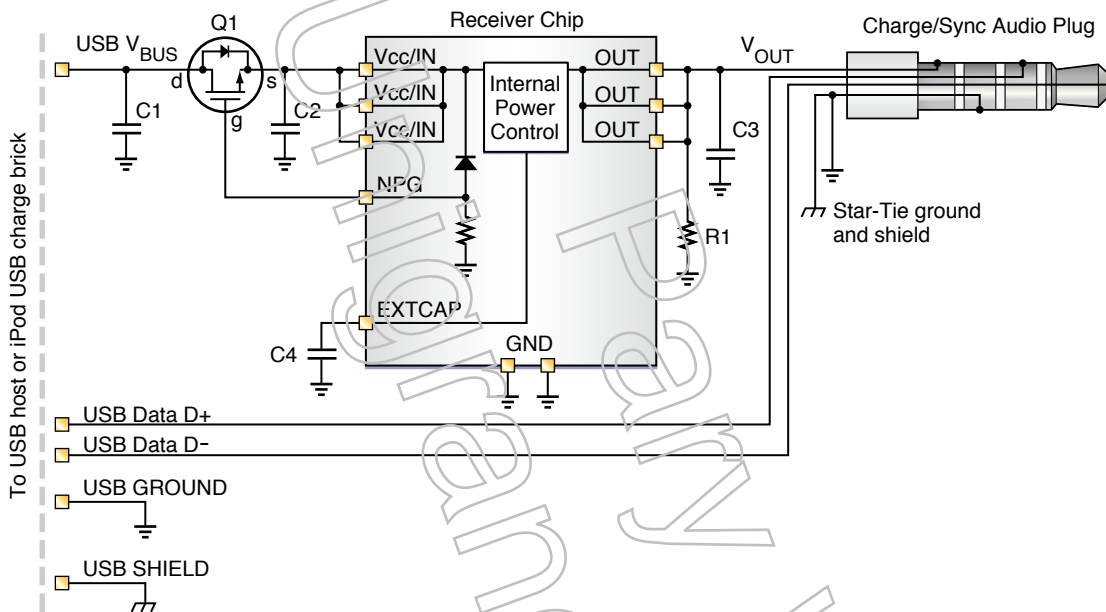

WARNINGS: Total DC resistance for the charging current between V_{BUS} and USB ground from the source to the audio plug must not exceed 900 milliohms, including the receiver chip's worst-case resistance of 300 milliohms.

Total capacitance between V_{OUT} and GND **must** be 0.1 μF ±20%.

Table A-7 Circuit components

Symbol	Description	Notes
C1	Capacitor, 1 μF, 16 V	
C2	Capacitor, 1 μF, 16 V	
C3	Capacitor, 0.1 μF, 6.3 V ±20%	Ceramic capacitor close to the receiver chip.
C4	Capacitor, 0.1 μF, 6.3 V	
Q1	MOSFET, 20 V	Negative voltage limiter, such as Fairchild FDMA520PZ.
R1	Resistor, 470 kΩ	

Design Certification

This section describes the testing procedures for signal line capacitance and charging current shutoff that must be performed on every new design of a charging accessory for the iPod 3G shuffle. These tests must be conducted by the third-party licensee. The licensee must then self-certify the results and include a copy of that certification in the self-certification documentation sent to Apple.

Signal Line Capacitance

Ring 4 of the accessory plug specified in [“Analog Audio Connection”](#) (page 19) passes information between the receiver chip in the accessory and the transmitter circuitry in the 3G shuffle. Its passive capacitance to ground (ring 3) must be verified to be within $\pm 20\%$ of $0.1 \mu\text{F}$, as specified in [Table A-7](#) (page 28).

Charging Current On and Off

The charging accessory's power output must operate correctly in both Mode 1 and Mode 2, even when there is electrical noise on its 5 V USB V_{BUS} power source. To verify this requirement, use a function generator to inject a 200 mV peak-to-peak 150 kHz triangle waveform over the 5V source. At the same time, the current output from the accessory must be monitored. When the accessory is plugged into the shuffle, it must provide charging current of +5 VDC at current drains up to 200 mA. When it is unplugged from the shuffle its electrical characteristics must return to Mode 1 within 240 ms, as specified by the t_{ms} parameter listed in [Table A-6](#) (page 27). The Mode 1 electrical characteristics to which the accessory must return are shown in [Table A-5](#) (page 27).



Urniğrand
Party
MNU
LTD
Urniğrand



Document Revision History

This table describes the changes to *iPod shuffle Interface Specification*.

Date	Notes
2011-04-04	<i>Release R8</i> : Updated "Notice of Proprietary Property" (page 7).
2009-05-04	<i>Release R7</i> : Added appendix Charging Accessories for the 3G shuffle (page 23). Added plug output to " 3G shuffle Play Controllers " (page 21).
2009-03-31	<i>Release R6</i> : Added chapter 3G shuffle Interface Specification (page 19). Added Table 1-1 (page 7) to list shuffle model numbers and interfaces.
2006-10-30	<i>Release R2</i> : Added specifications for the 2G shuffle.
2006-03-21	Initial release.



Unigraand Party MNU
unigraand LTD