

GALLO 1.0

PV BUILD

2006.02.08

DATE	CHANGE NO.	REV

DRAWER	EE	DATE	POWER	DATE	TITLE
DESIGN					INVENTEC
CHECK					GALLO 1.0
RESPONSIBLE					
SIZE =	3		VER :		SIZE CODE DOC NUMBER REV
FILE NAME :	XXXX-XXXXXX-XX				A3 CS Model No A01
P/N	XXXXXXXXXXXX				SHEET 1 OF 58

mailto:help@inventec.com

TABLE OF CONTENTS

PAGE

- 5- DC& BATTERY CHARGER
- 6- SELECT & BATTERY CONN
- 7- SYSTEM POWER(3V/5V)
- 8- SYSTEM POWER(V2.5S/V1.5A)
- 9- SYSTEM POWER(VCCP/VGAVCC)
- 10- SYSTEM POWER(V1.8/V0.9S)
- 11- CPU POWER(VCC_CORE)
- 12- DDR TERMINATION VOLTAGE
- 13- POWER(SLEEP)
- 14- POWER(SEQUENCE)
- 15- CLOCK_GENERATOR
- 16- YOHNA-1
- 17- YOHNA-2
- 18- YOHNA-3
- 19- YOHNA-4
- 20- THERMAL&FAN CONTROLLER
- 21- CALISTOGA-1
- 22- CALISTOGA-2

PAGE

- 23- CALISTOGA-3
- 24- CALISTOGA-4
- 25- CALISTOGA-5
- 26- DDR2-DIMM0
- 27- DDR2-DIMM1
- 28- DDR2-DAMPING
- 29- CRT & SVEDIO CONN
- 30- LCD CONN
- 31- ICH7-1
- 32- ICH7-2
- 33- ICH7-3
- 34- ICH7-4
- 35- ICH7-5
- 36- KBC
- 37- SPI/HDD PROTECTION
- 38- INT.KBC/POINT DEVICES
- 39- SUPER I/O
- 40- AC97/AZALIA CODEC

PAGE

- 41- EQ&MIC JACK
- 42- AUDIO AMP&HP JACK
- 43- HDD CONN
- 44- ODD CONN
- 45- USB CONN
- 46- CARDBUS CONTROLL
- 47- PC CARD SLOT
- 48- 1394 CONN
- 49- MINICARD CONN
- 50- LAN INTERFACE-1
- 51- LAN RJ45 CONN
- 52- DOCKING CONN
- 53- SCREW
- 54- MDC1.5 CONN
- 55- BLUETOOTH
- 56- BUTTON & SWITCH & LED
- 57- LED/SWITCH CONN
- 58- LED/SWITCH BOTTON BOARD

INVENTEC

TITLE *GALLO 1.0*

SIZE A3	CODE CS	DOC. NUMBER <i>Model No</i>	REV A01
SHEET		2	OF 58

CHANGE by *CHANG ALEX* 8-Feb-2006

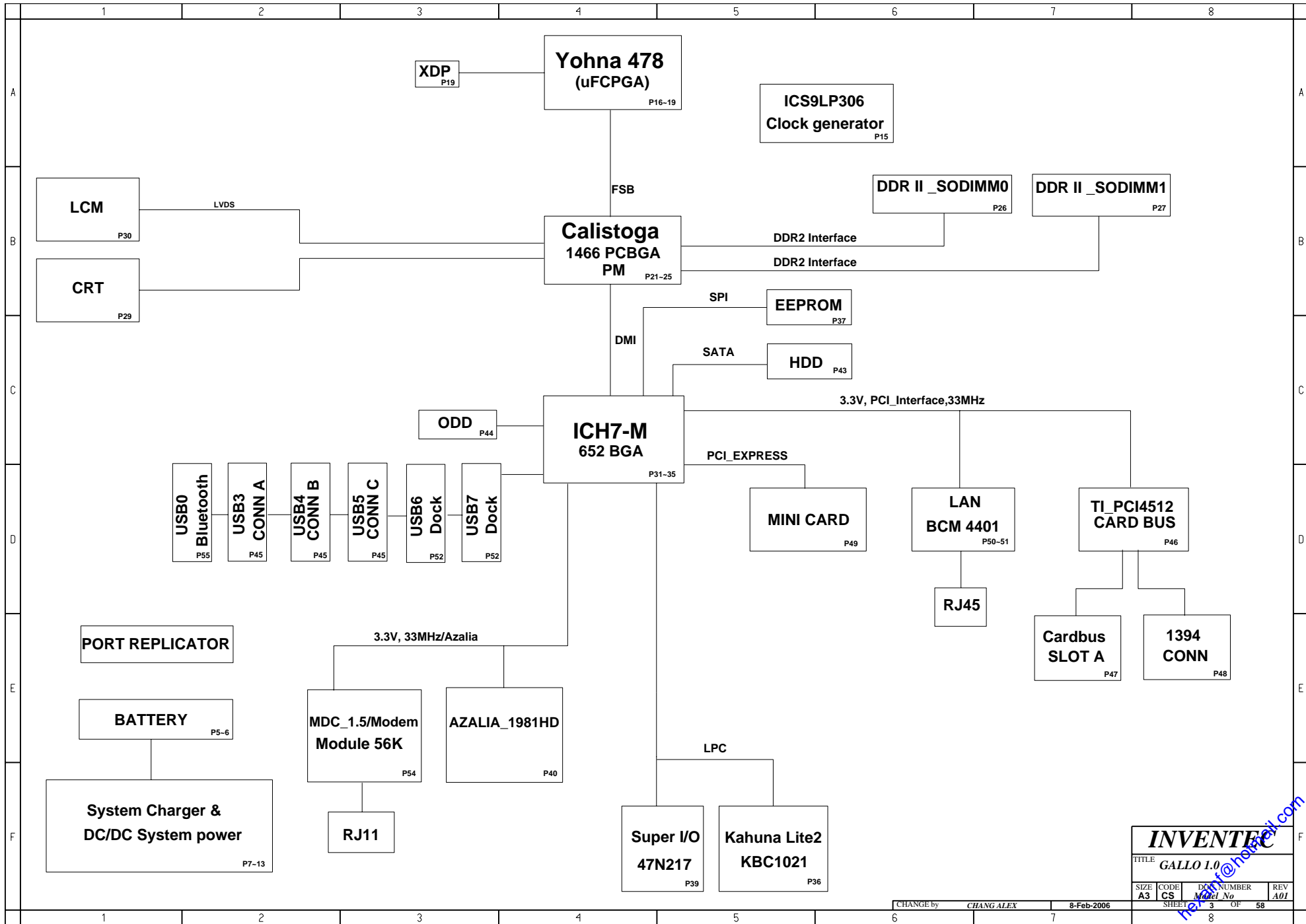

INVENTEC			
TITLE GALLO 1.0			
SIZE A3	CODE CS	DOC NUMBER Model No	REV A01
CHANGE by CHANG ALEX		8-Feb-2006	
SHEET 3		OF 58	

mailto:alex@inventec.com

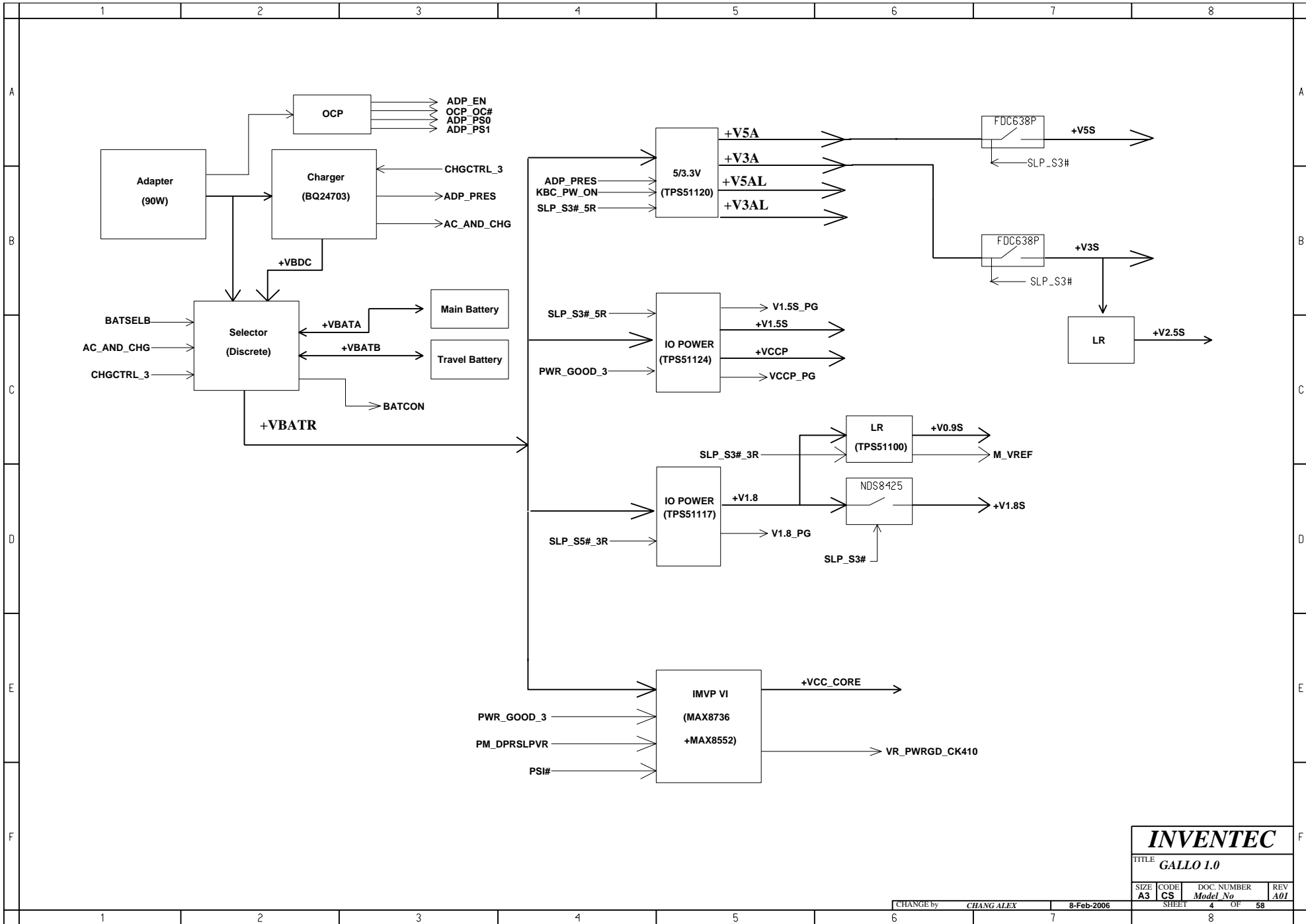

INVENTEC

TITLE GALLO 1.0

SIZE	CODE	DOC. NUMBER	REV
A3	CS	Model No	A01

CHANGE by CHANG ALEX 8-Feb-2006 SHEET 4 OF 58

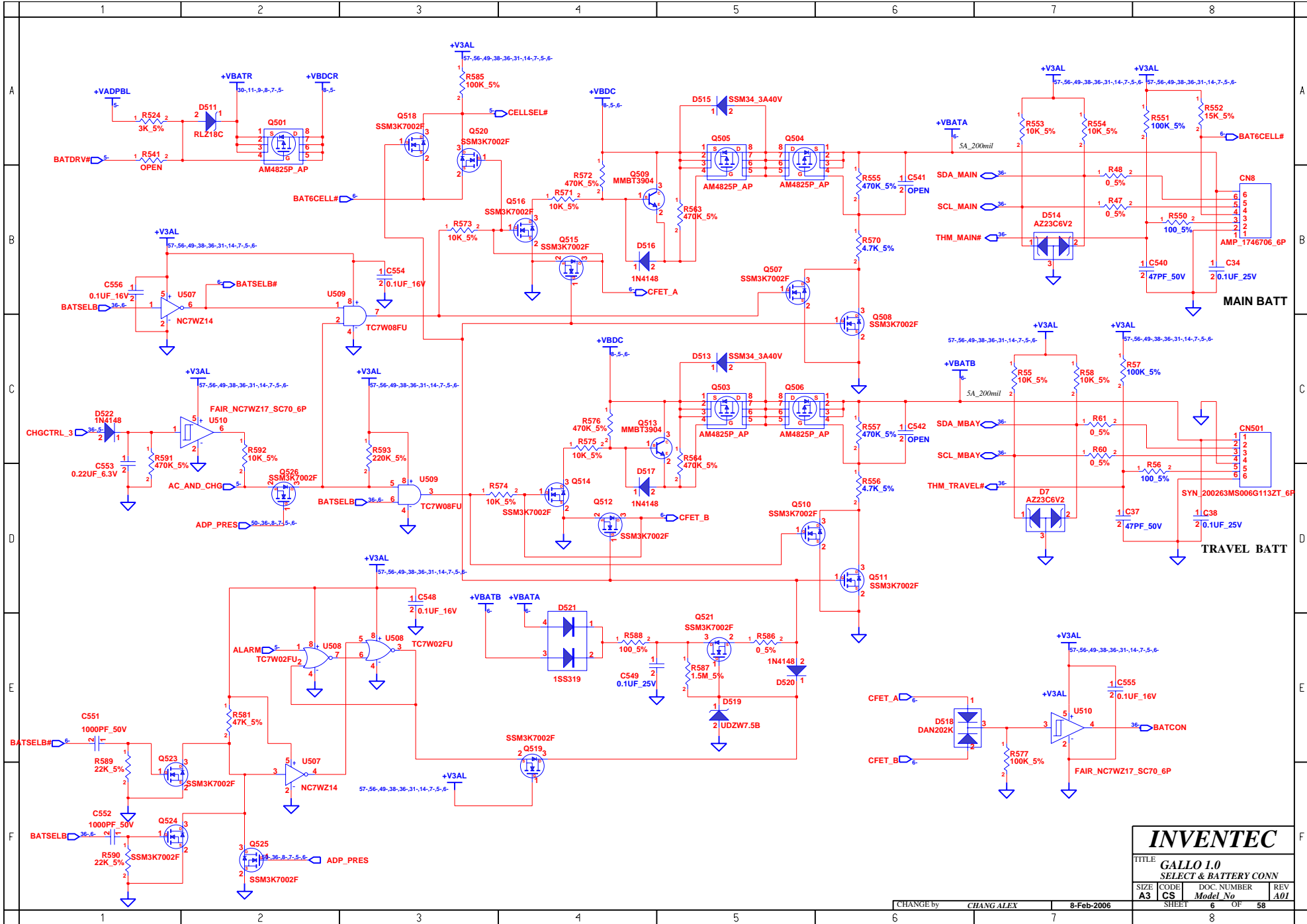

INVENTEC			
TITLE GALLO I.0 SELECT & BATTERY CONN			
SIZE A3	CODE CS	DOC. NUMBER <i>Model No</i>	REV A01
CHANGE by <i>CHANG ALEX</i>		8-Feb-2006	
SHEET 6		OF 58	

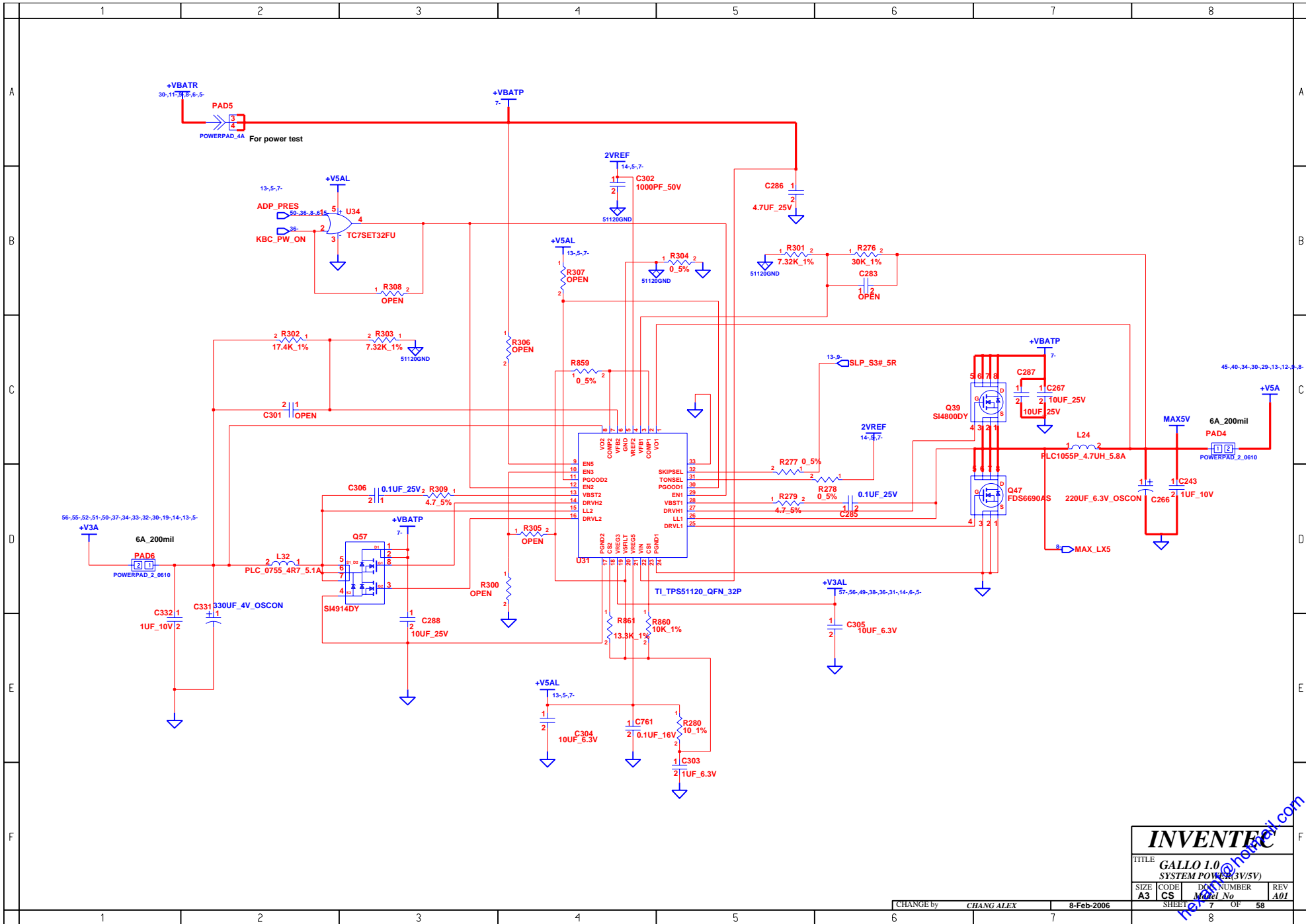

INVENTEC			
TITLE GALLO I.0 SYSTEM POWER(3V/5V)			
SIZE A3	CODE CS	DOC NUMBER Model No	REV A01
CHANGE by CHANG ALEX		8-Feb-2006	
SHEET 7		OF 58	

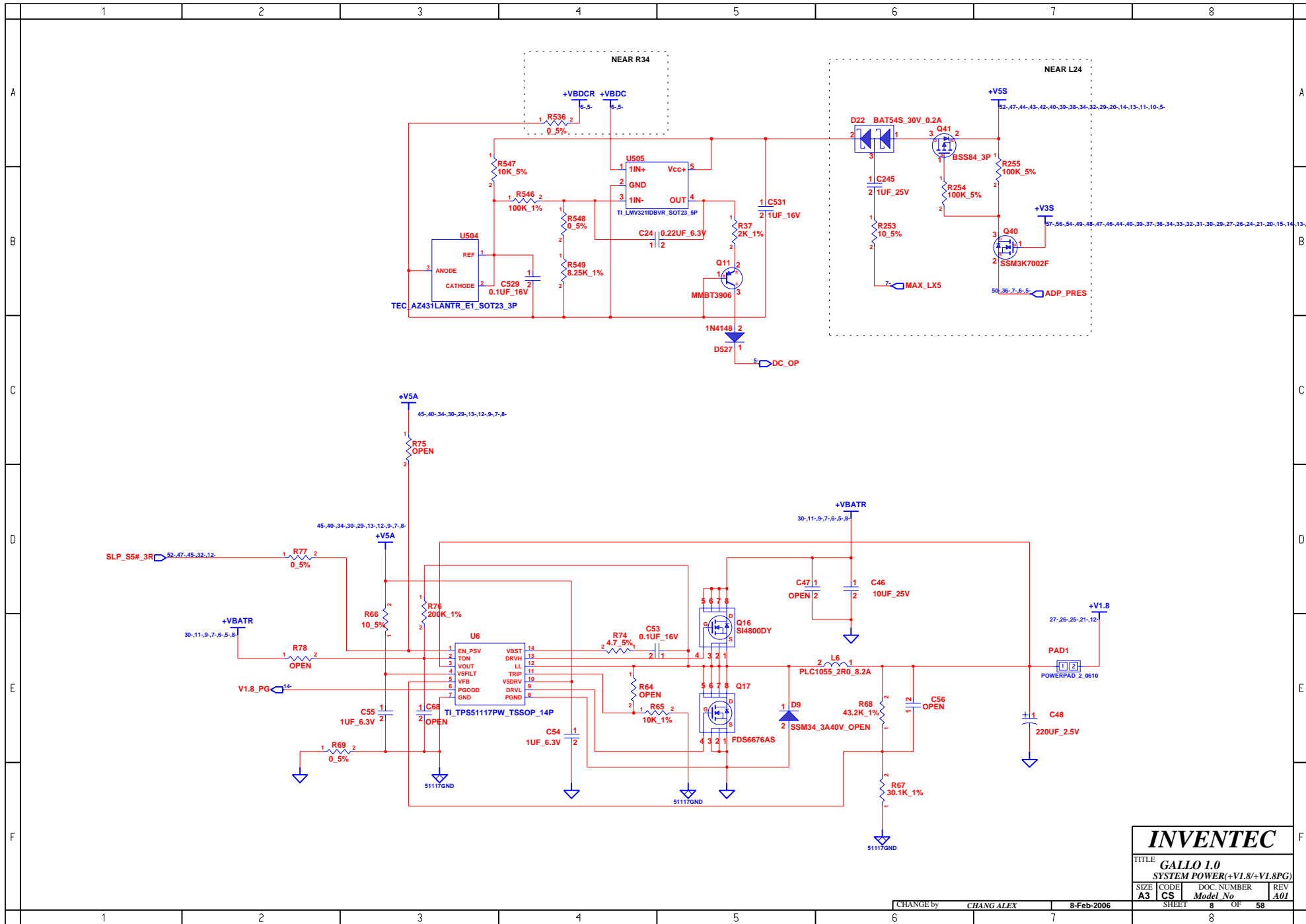

INVENTEC			
TITLE GALLO I.0			
SYSTEM POWER(+V1.8/+V1.8PG)			
SIZE A3	CODE CS	DOC. NUMBER Model No	REV A01
CHANGE by CHANG ALEX		8-Feb-2006	
SHEET 8		OF 58	

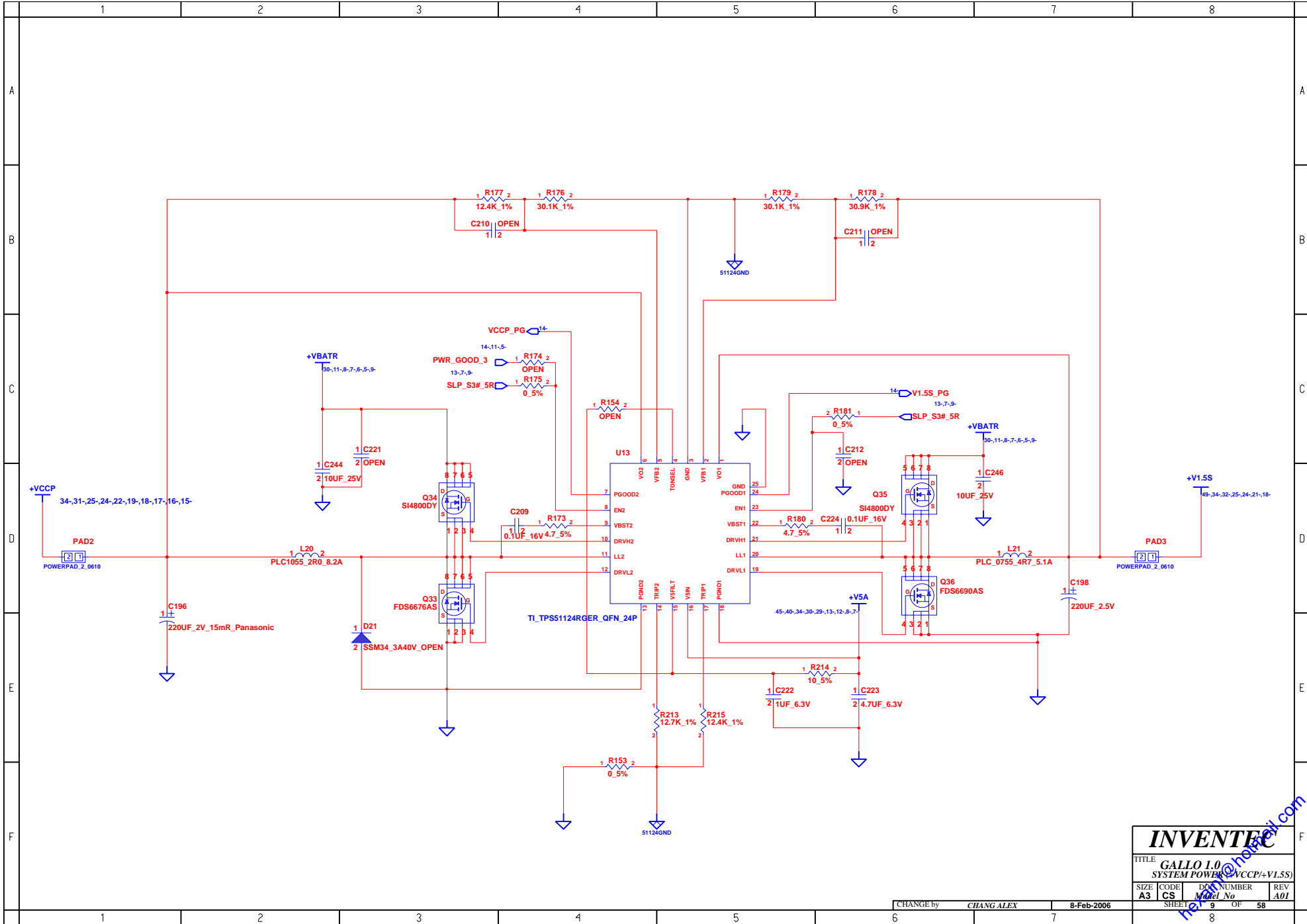

INVENTEC			
TITLE: GALLO I.0 SYSTEM POWER (+VCCP/+V1.5S)			
SIZE: A3	CODE: CS	DOC NUMBER: Model No	REV: A01
CHANGE by: CHANG ALEX		8-Feb-2006	SHEET 9 OF 58

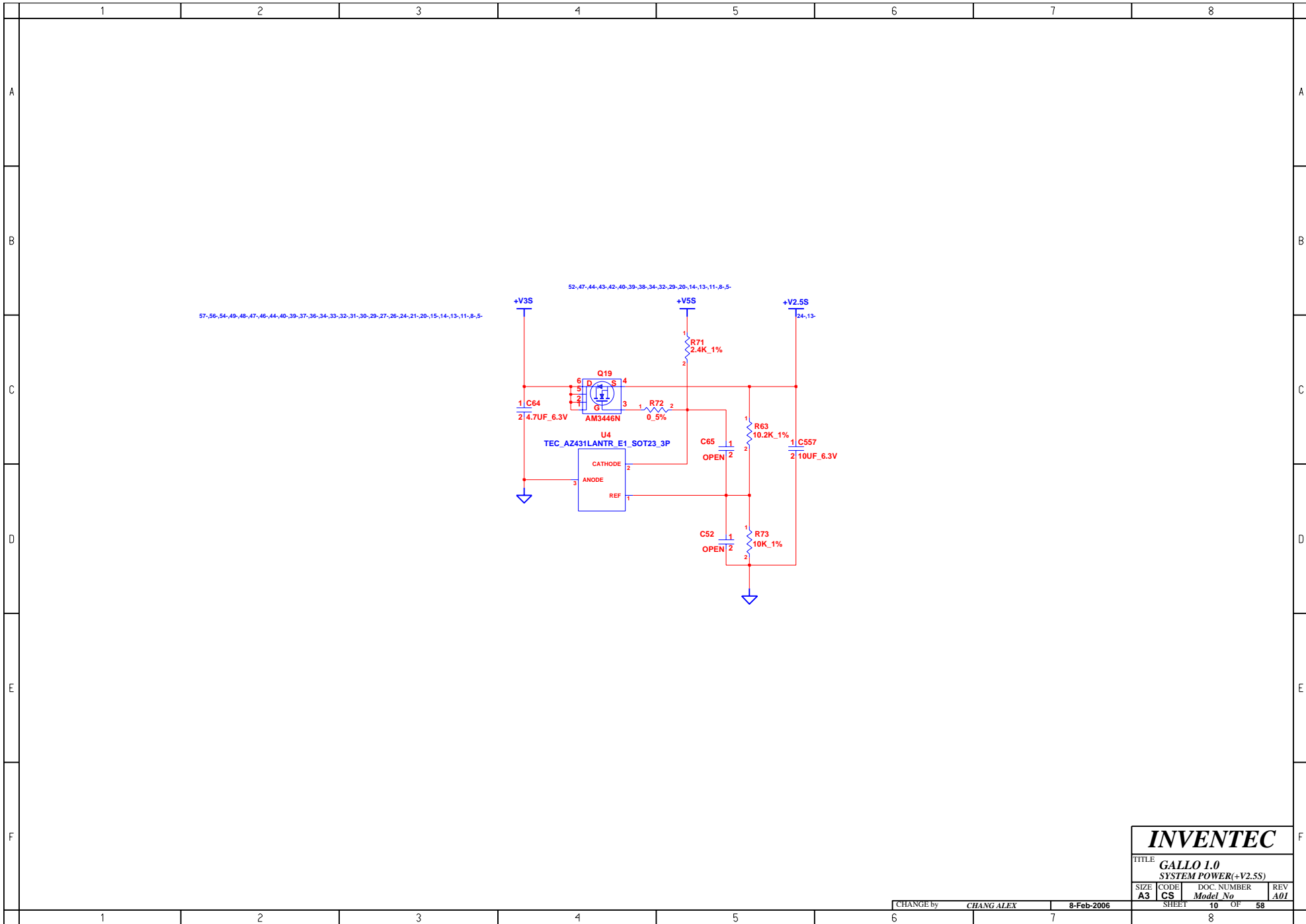

INVENTEC

TITLE **GALLO 1.0**
SYSTEM POWER(+V2.5S)

SIZE A3	CODE CS	DOC. NUMBER <i>Model No</i>	REV A01
SHEET 10 OF 58			

LAYOUT NOTES: C1779 C502 C503 PIN2 CONNECT TO Q14 , Q18 GND
 C1780 C532 C531 PIN2 CONNECT TO Q16 , Q20 GND

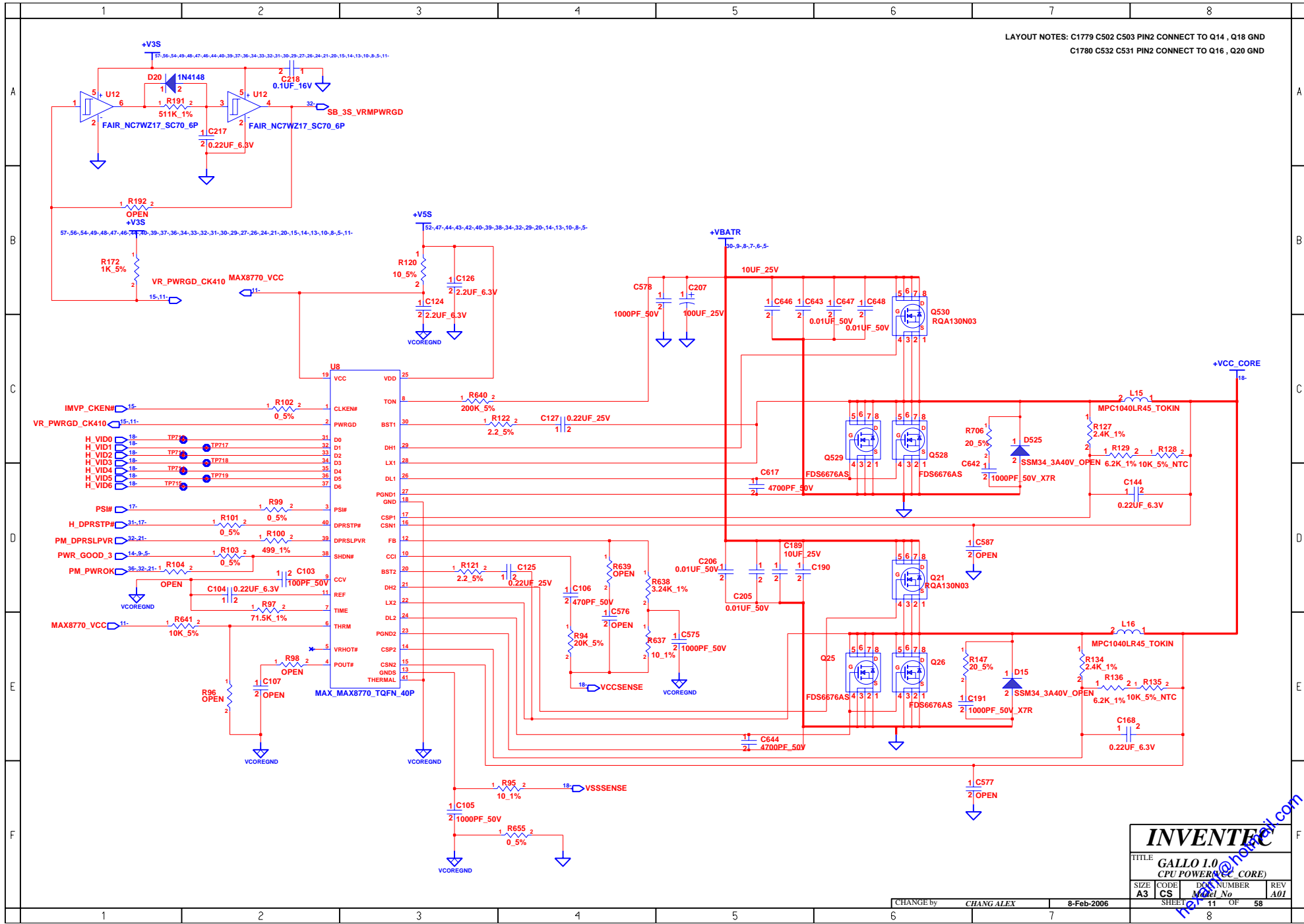

INVENTEC			
TITLE GALLO I.0 CPU POWER (CC CORE)			
SIZE A3	CODE CS	DOC NUMBER Model No	REV A01
CHANGE by CHANG ALEX		8-Feb-2006	
SHEET 11		OF 58	

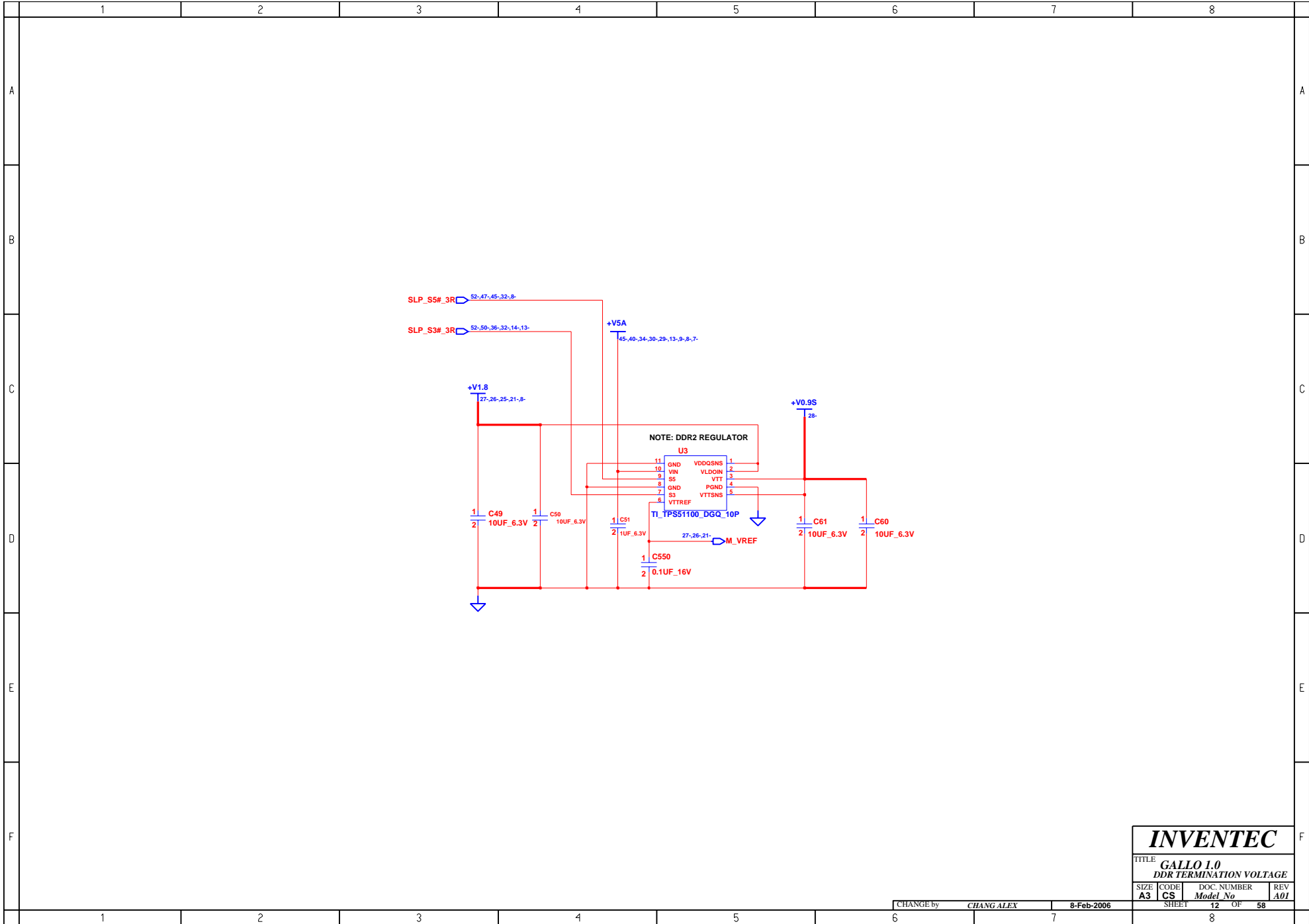

INVENTEC			
TITLE GALLO 1.0 DDR TERMINATION VOLTAGE			
SIZE A3	CODE CS	DOC. NUMBER Model No	REV A01
CHANGE by CHANG ALEX		8-Feb-2006	SHEET 12 OF 58

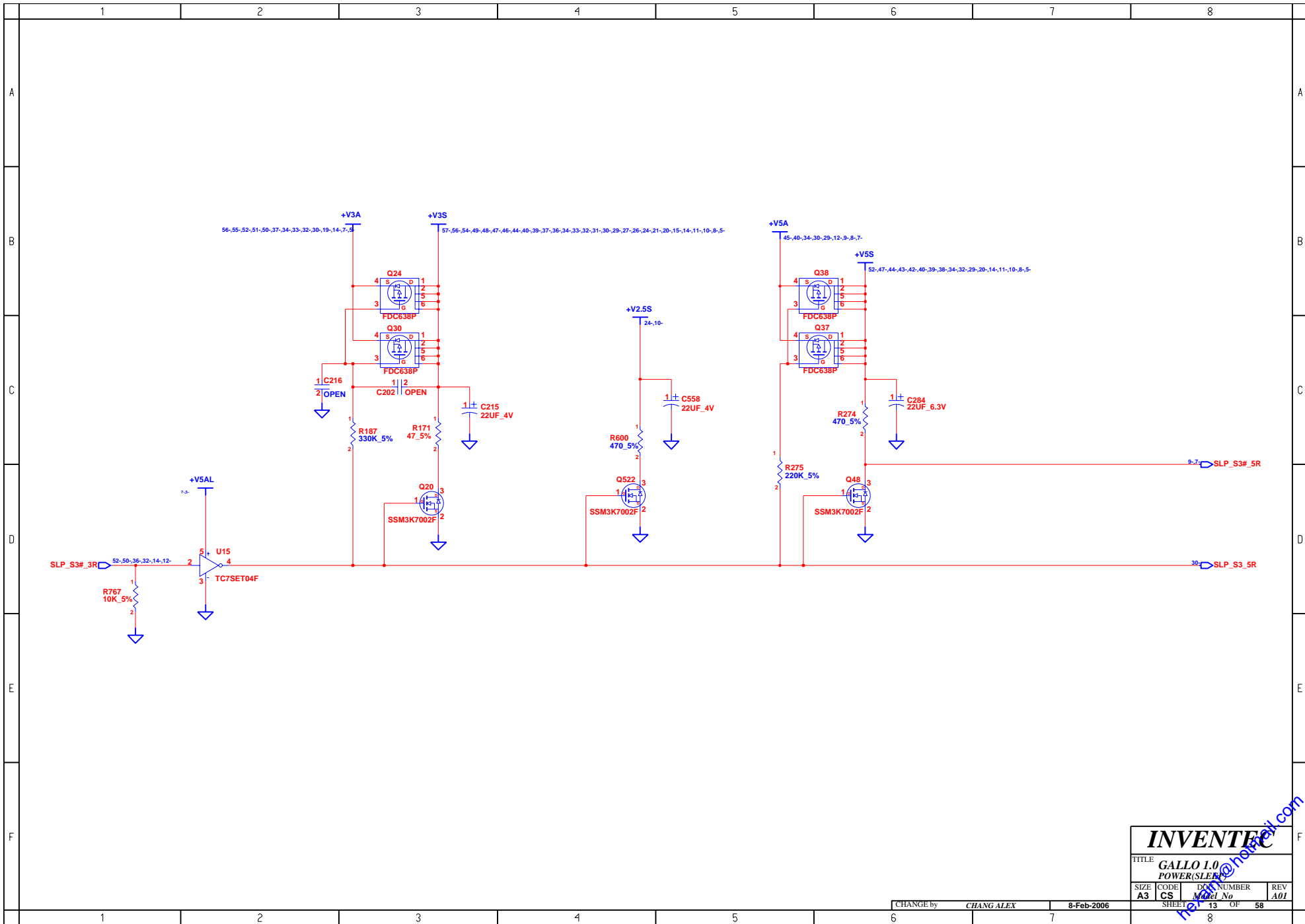

INVENTEC			
TITLE GALLO 1.0 POWER(SLER)			
SIZE A3	CODE CS	DOC NUMBER <i>Model No</i>	REV A01
CHANGE by <i>CHANG ALEX</i>		8-Feb-2006	
SHEET 13		OF 58	

http://www.inventec.com

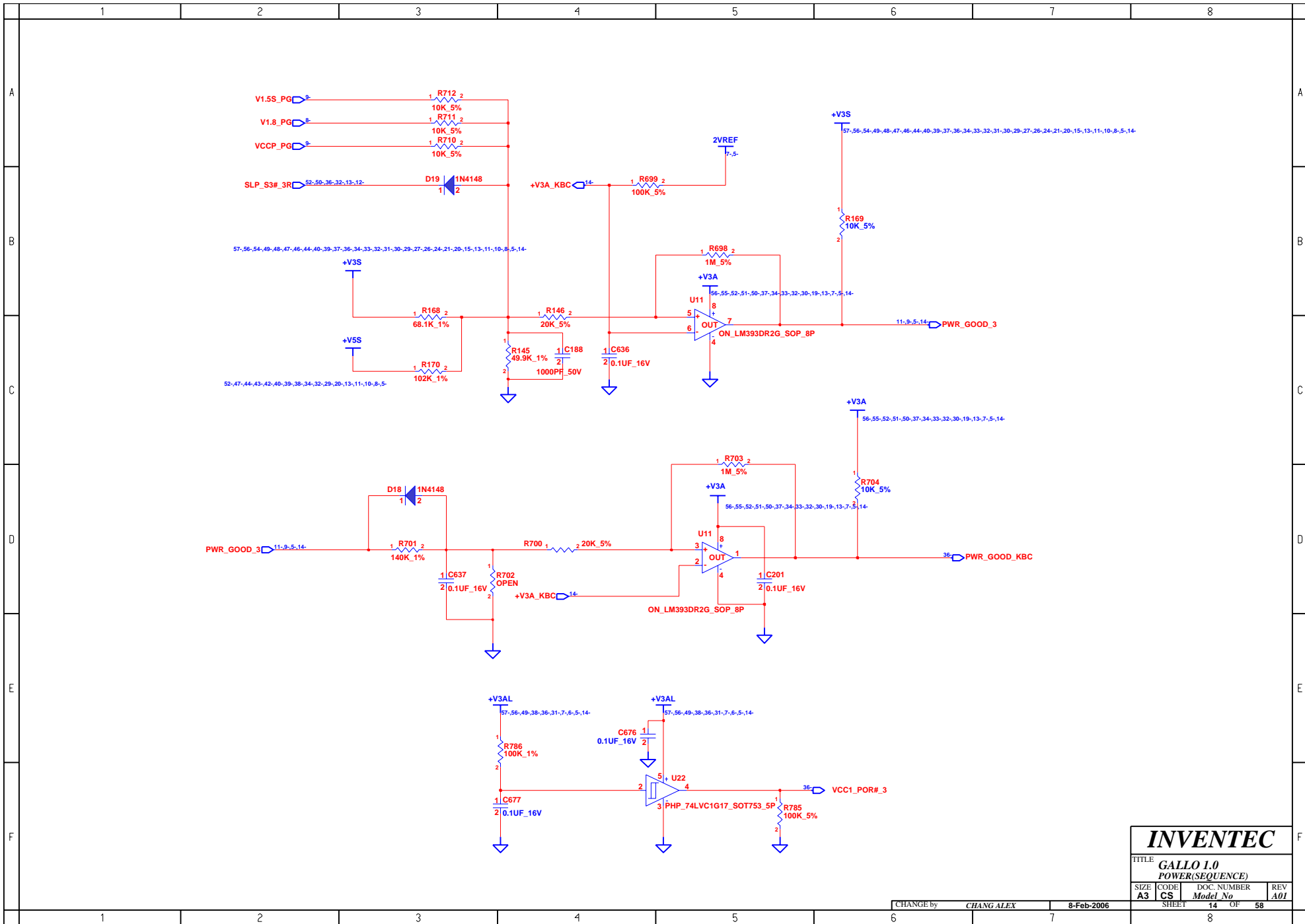

INVENTEC

TITLE			
GALLO 1.0			
POWER(SEQUENCE)			
SIZE	CODE	DOC. NUMBER	REV
A3	CS	Model No	A01

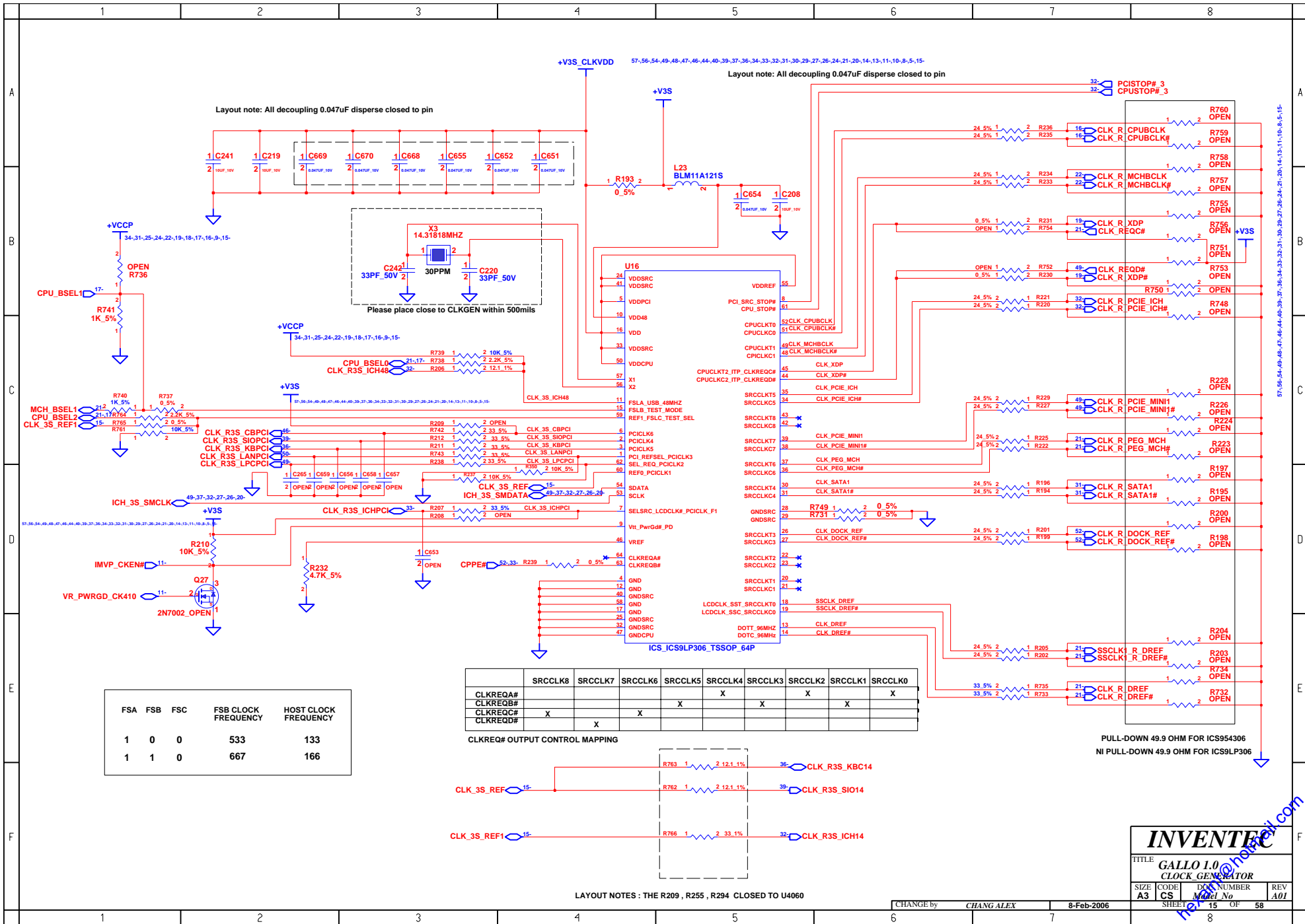

Layout note: All decoupling 0.047uF disperse closed to pin

Layout note: All decoupling 0.047uF disperse closed to pin

Please place close to CLKGEN within 500mils

FSA	FSB	FSC	FSB CLOCK FREQUENCY	HOST CLOCK FREQUENCY
1	0	0	533	133
1	1	0	667	166

	SRCCLK8	SRCCLK7	SRCCLK6	SRCCLK5	SRCCLK4	SRCCLK3	SRCCLK2	SRCCLK1	SRCCLK0
CLKREQA#				X	X	X	X	X	X
CLKREQB#									
CLKREQC#	X		X						
CLKREQD#		X							

CLKREQ# OUTPUT CONTROL MAPPING

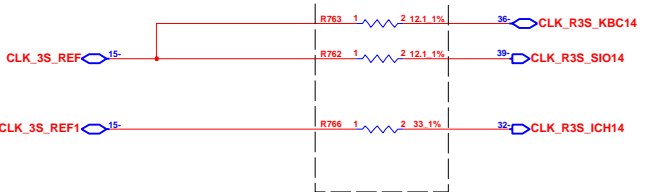

LAYOUT NOTES : THE R209 , R255 , R294 CLOSED TO U4060

PULL-DOWN 49.9 OHM FOR ICS954306
NI PULL-DOWN 49.9 OHM FOR ICS9LP306

INVENTEC

TITLE: GALLO I.0
CLOCK GENERATOR

SIZE	CODE	DOC NUMBER	REV
A3	CS	Model No	A01

SHEET 15 OF 58

CHANGE by: CHANG ALEX 8-Feb-2006

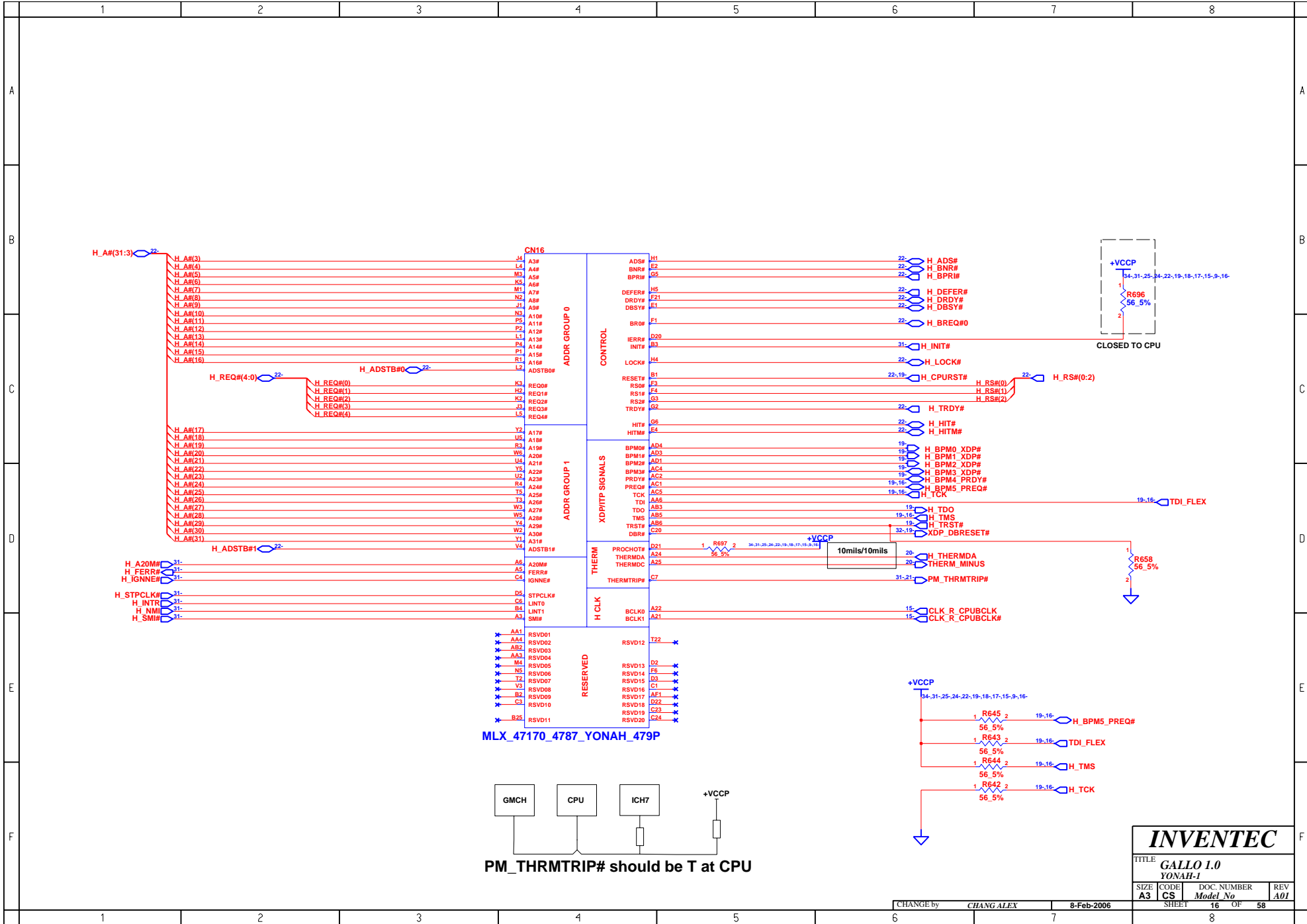

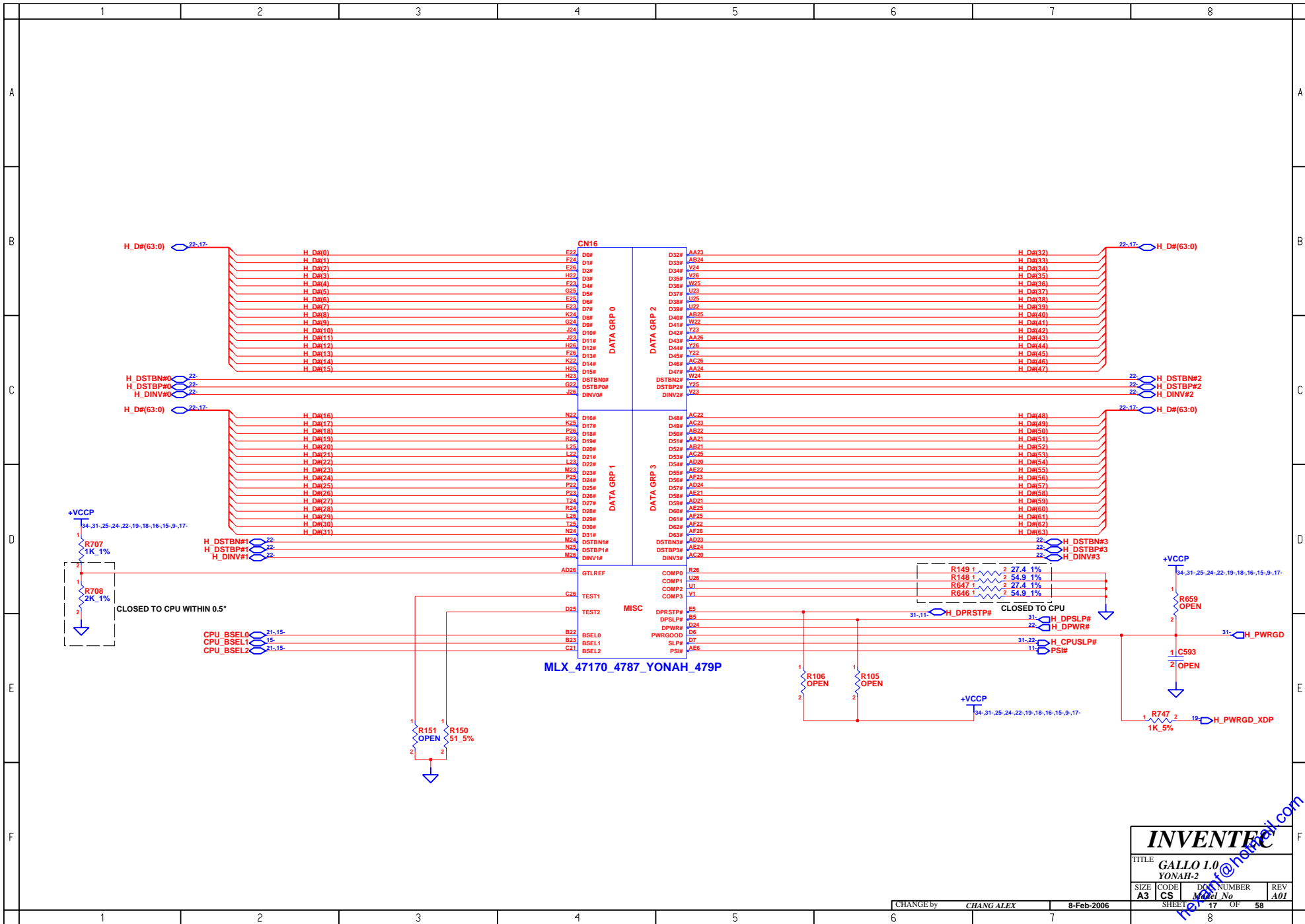

INVENTEC			
TITLE GALLO 1.0 YONAH-2			
SIZE A3	CODE CS	DOC NUMBER Model No	REV A01
CHANGE by CHANG ALEX		8-Feb-2006	
SHEET 17		OF 58	

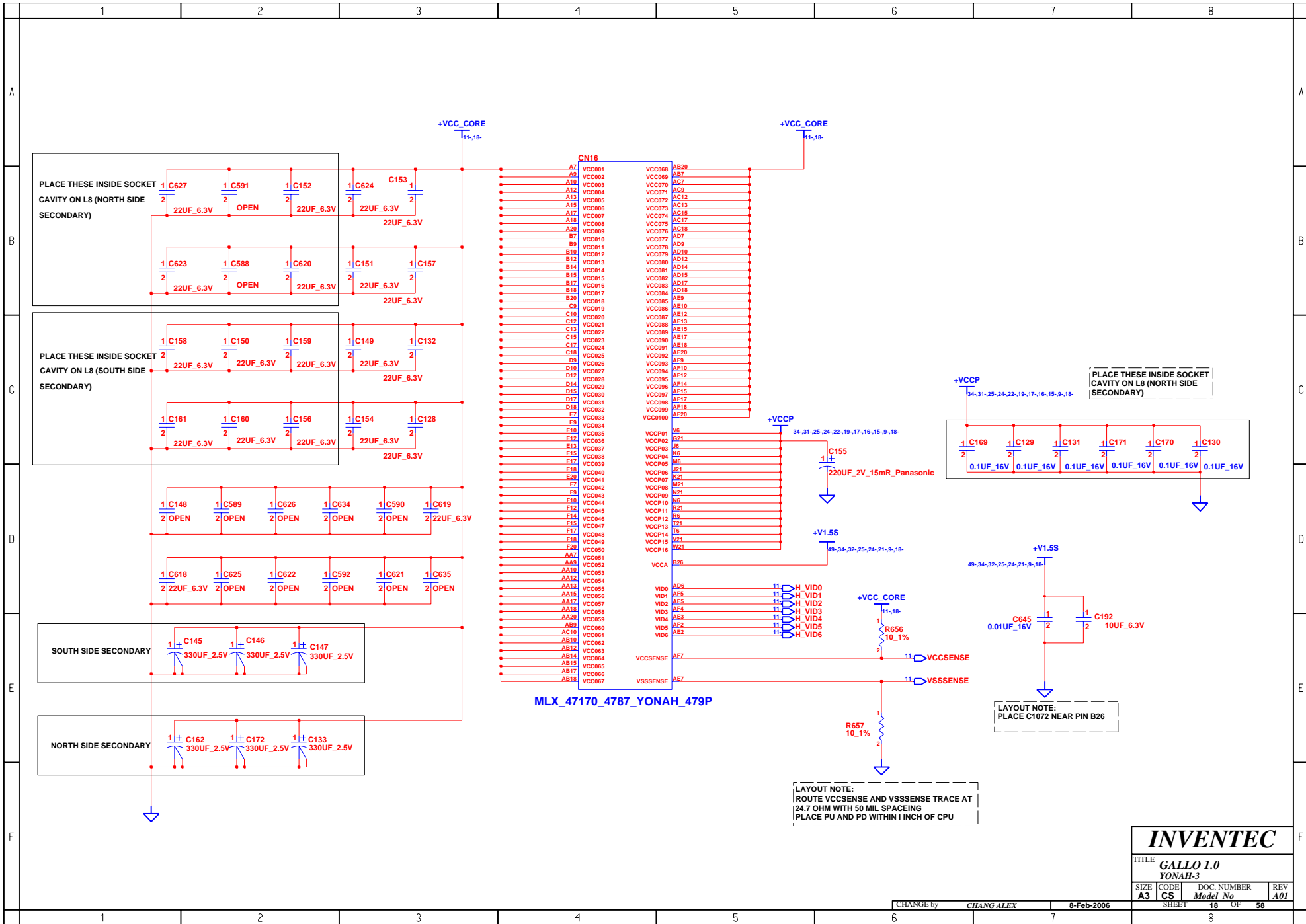

INVENTEC

TITLE			
GALLO 1.0			
YONAH-3			
SIZE	CODE	DOC. NUMBER	REV
A3	CS	Model No	A01
CHANGE by			SHEET
CHANG ALEX			18 OF 58

8-Feb-2006

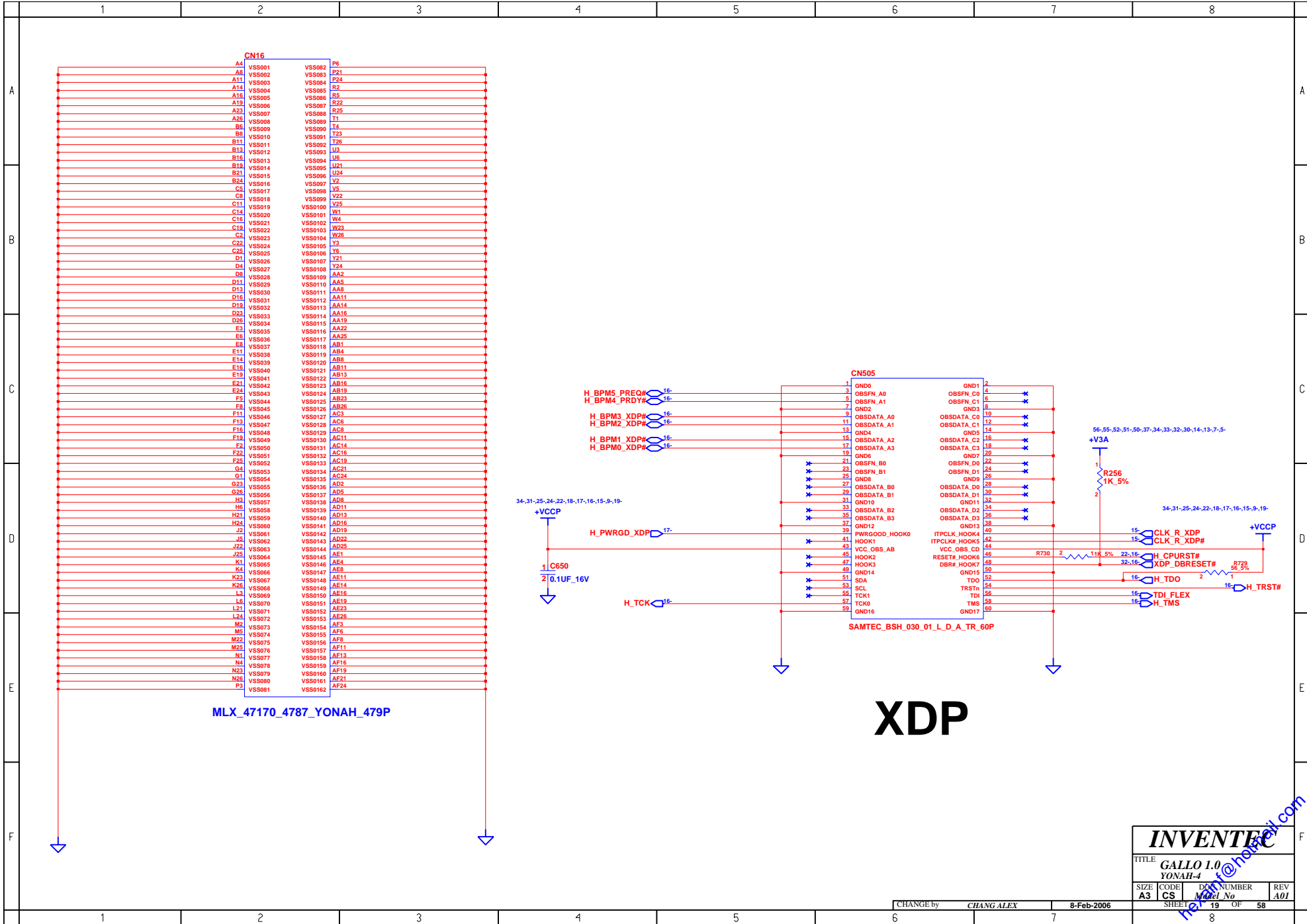

MLX_47170_4787_YONAH_479P

XDP

INVENTEC			
TITLE GALLO 1.0 YONAH-4			
SIZE A3	CODE CS	DOC NUMBER Model No	REV A01
CHANGE by CHANG ALEX		8-Feb-2006	
SHEET 19		OF 58	

mailto:inventec@inventec.com

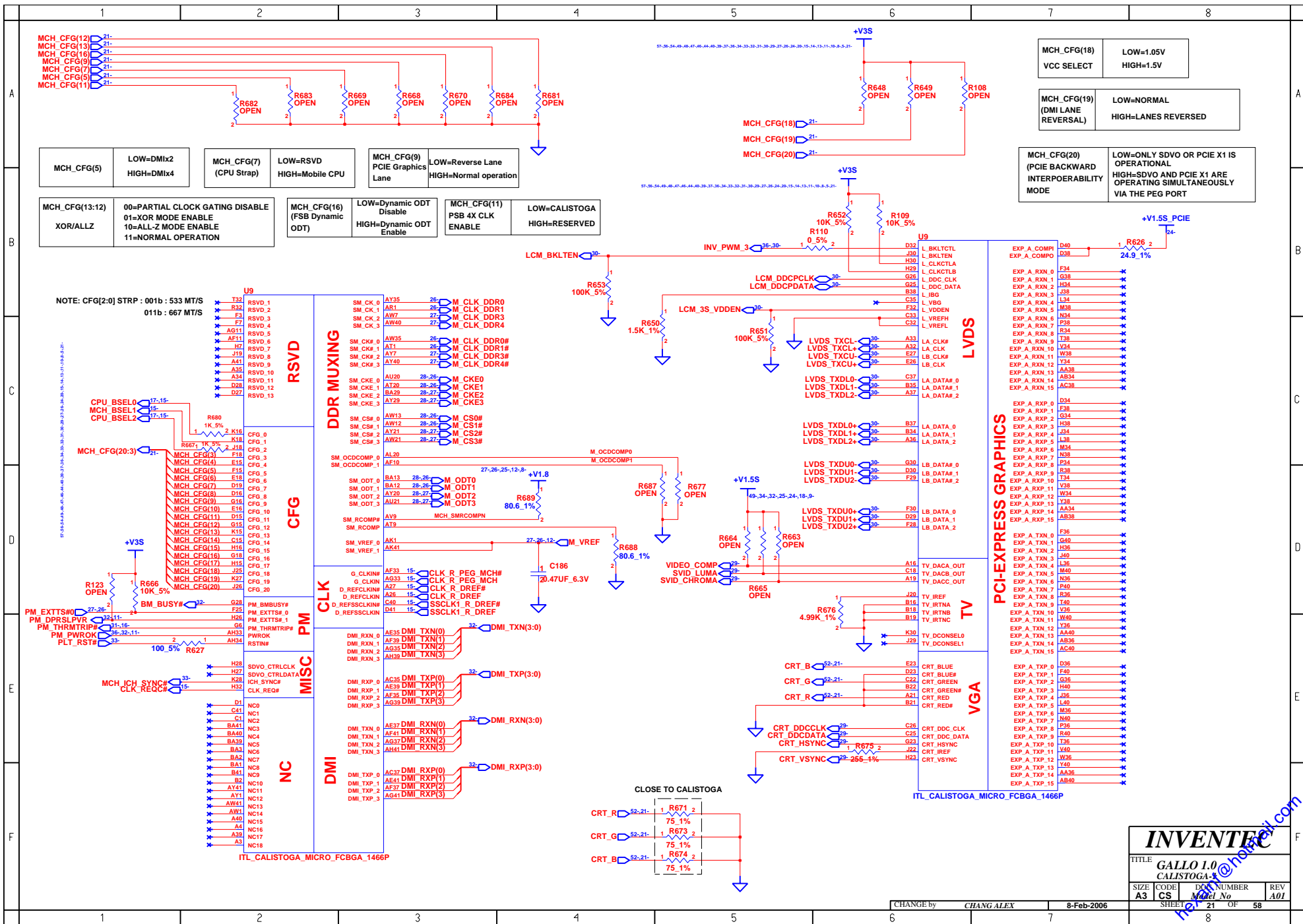

INVENTEC

TITLE: GALLO I.0 CALISTOGA-1

SIZE	CODE	DOC NUMBER	REV
A3	CS	Model No	A01

CHANGE by: CHANG ALEX 8-Feb-2006

SHEET 21 OF 58

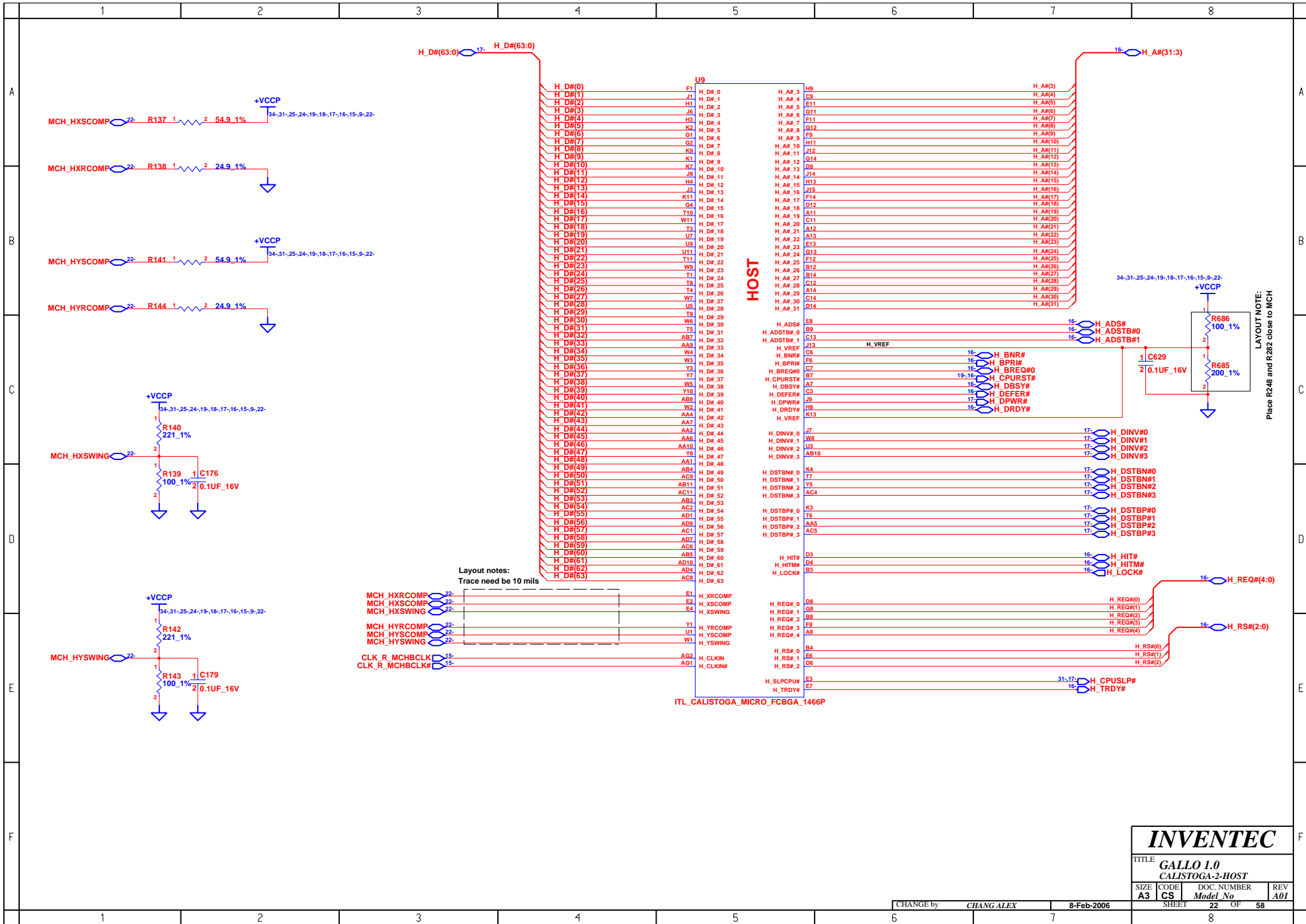

HOST

Layout notes:
Trace need be 10 mils

LAYOUT NOTE:
Place R248 and R282 close to MCH

INVENTEC			
TITLE GALLO I.0 CALISTOGA-2-HOST			
SIZE A3	CODE CS	DOC. NUMBER <i>Model No</i>	REV A01
CHANGE by CHANG ALEX		8-Feb-2006	
SHEET 22		OF 58	

ITL_CALISTOGA_MICRO_FCBGA_1466P

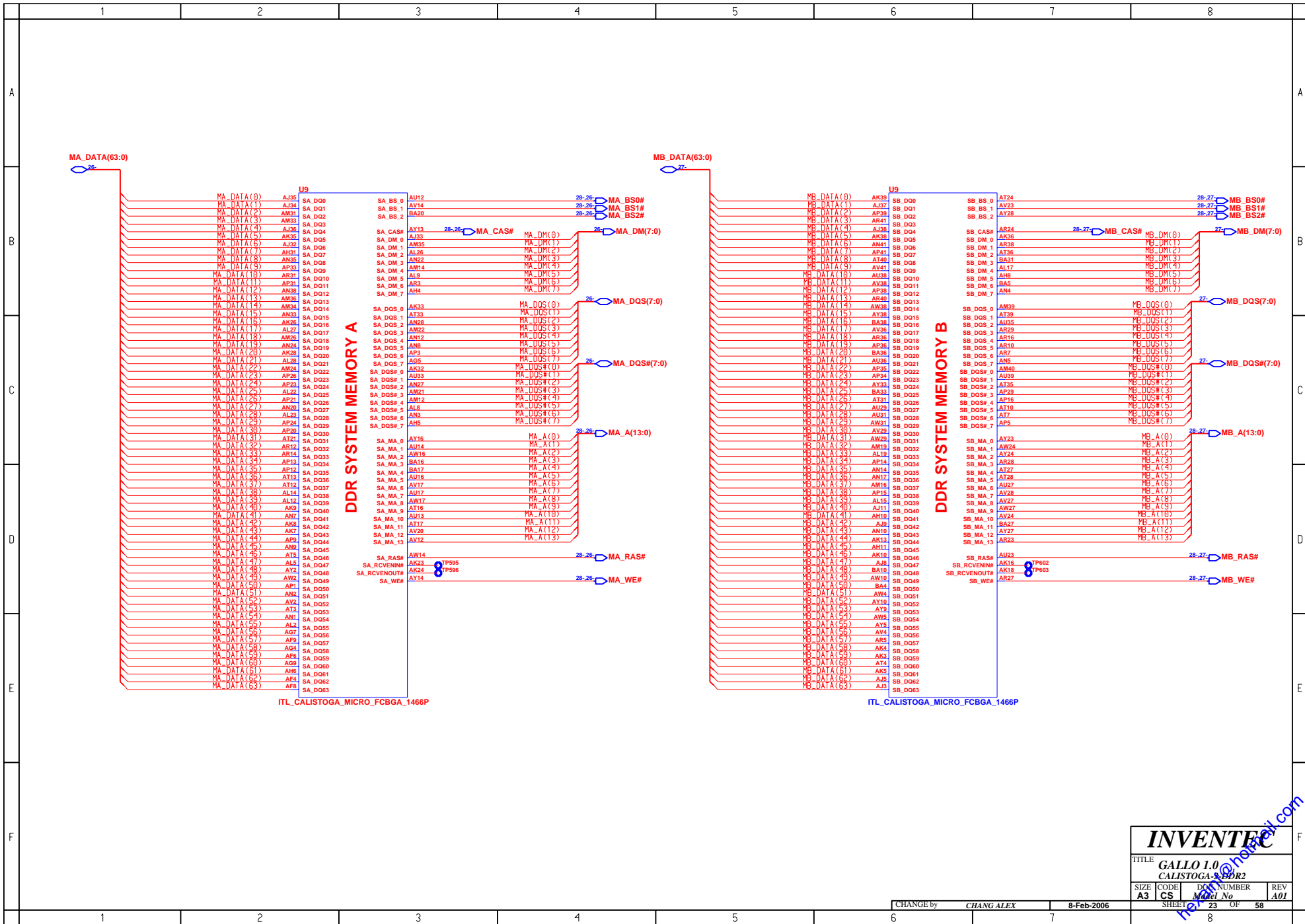

INVENTEC

TITLE: GALLO I.0
CALISTOGA-3DDR2

SIZE	CODE	DOC NUMBER	REV
A3	CS	Model No	A01

CHANGE by: CHANG ALEY 8-Feb-2006 SHEET 23 OF 58

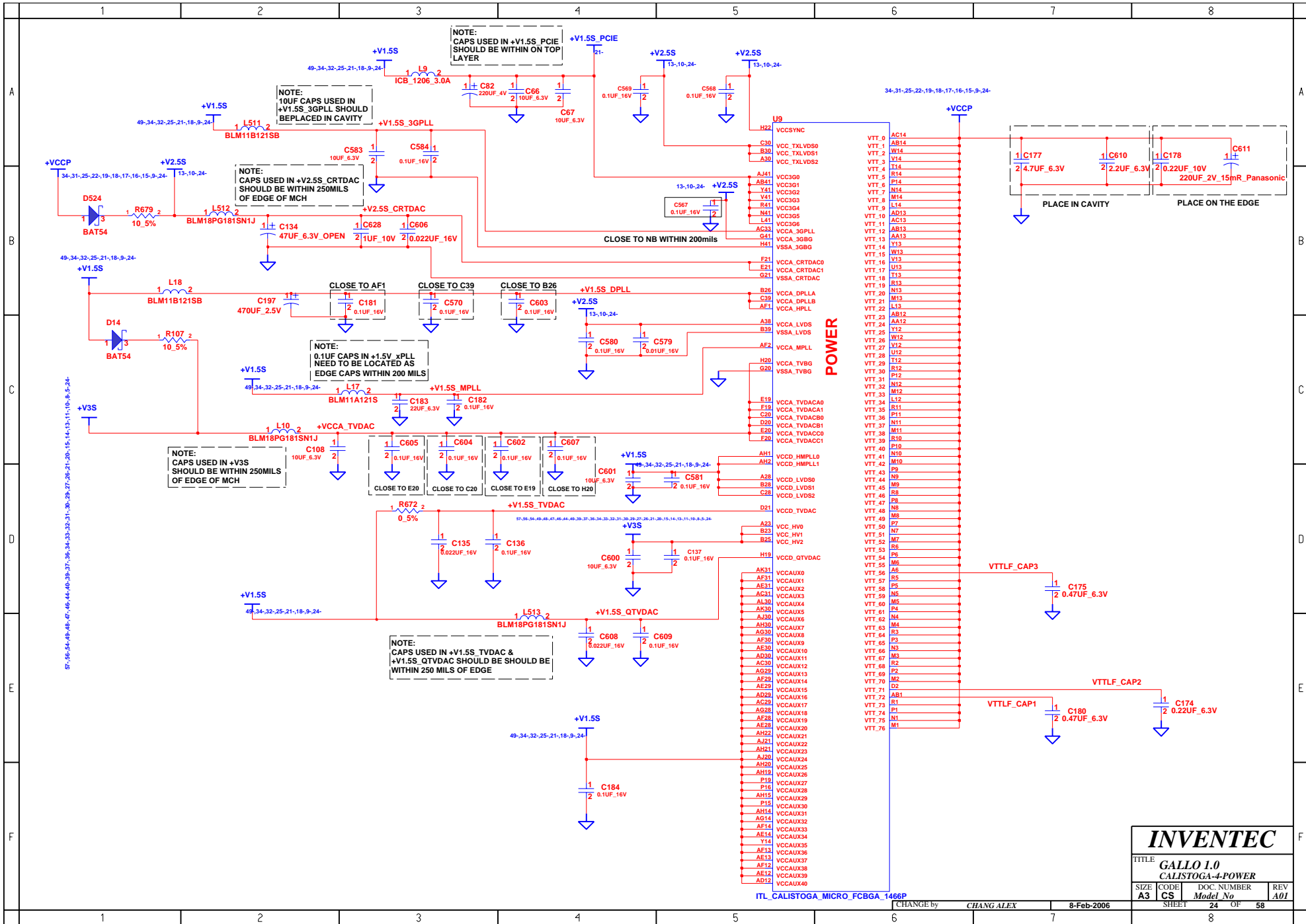

INVENTEC			
TITLE: GALLO I.0 CALISTOGA-4-POWER			
SIZE	CODE	DOC. NUMBER	REV
A3	CS	Model No	A01
SHEET		24 OF 58	

CHANGE by: CHANG ALEX 8-Feb-2006

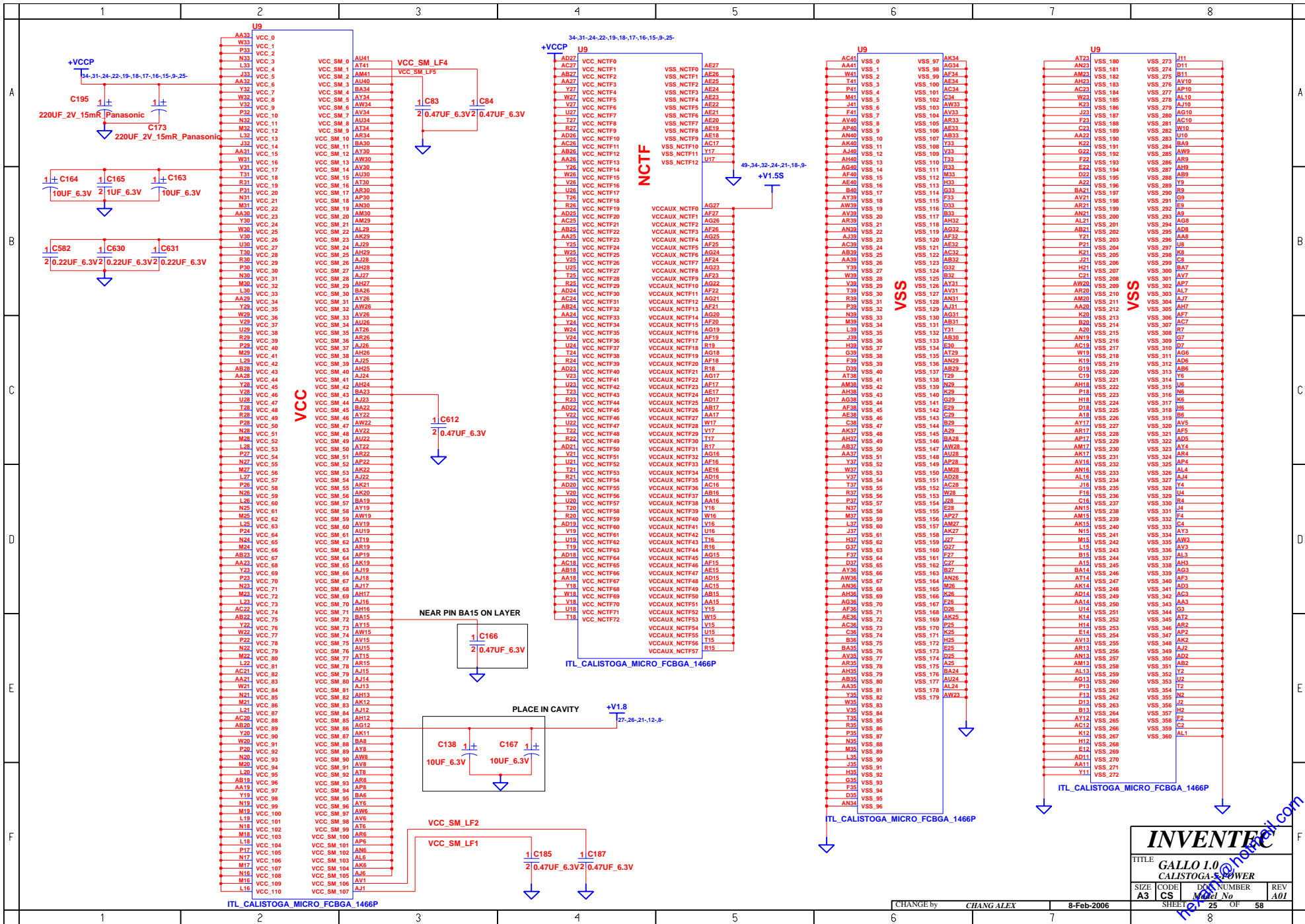

INVENTEC

TITLE: GALLO I.0
CALISTOGA POWER

SIZE	CODE	DOC NUMBER	REV
A3	CS	Model No	A01

SHEET 25 OF 58

CHANGE by: CHANG ALEX 8-Feb-2006

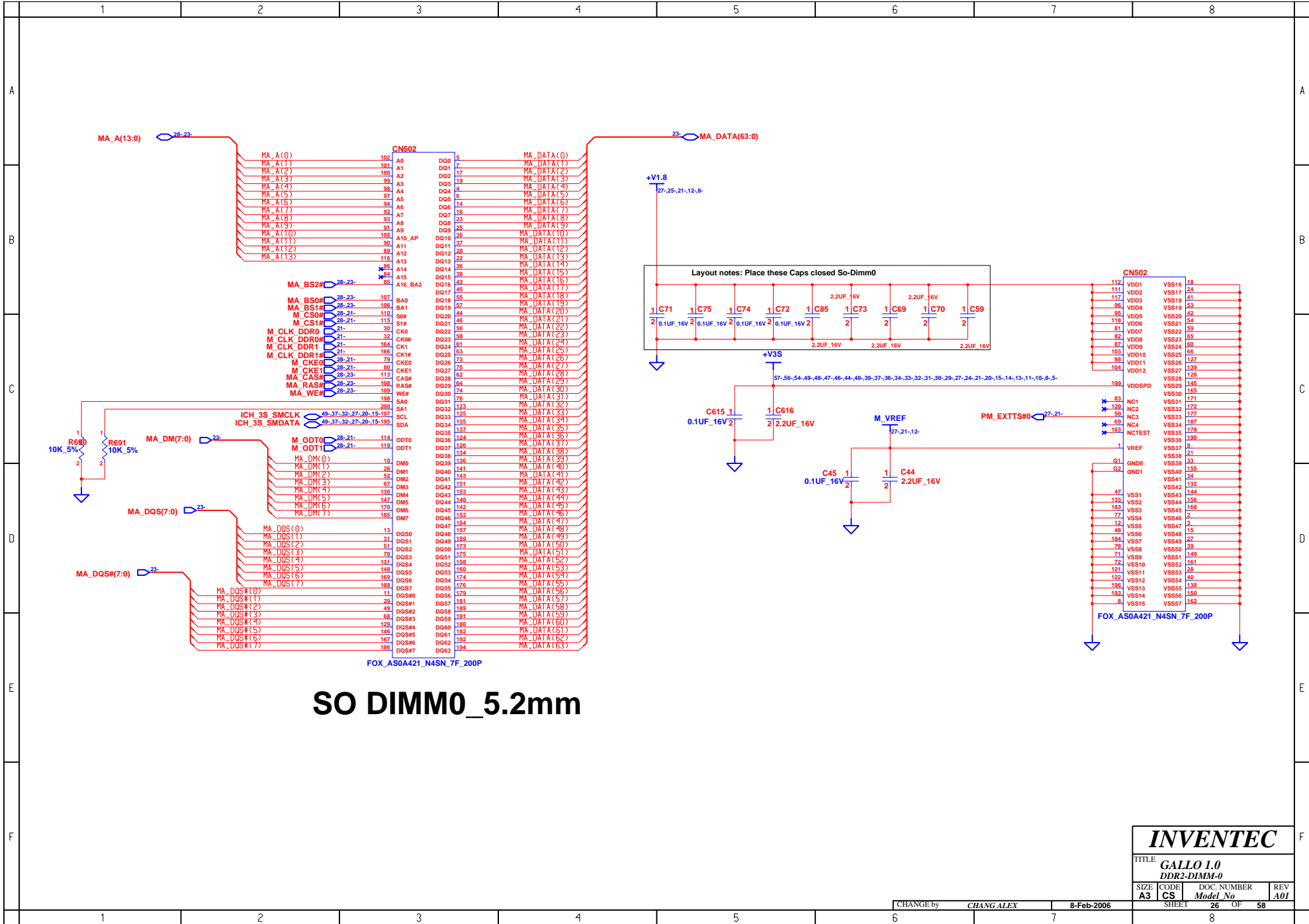

SO DIMM0_5.2mm

INVENTEC

TITLE GALLO I.0
DDR2-DIMM-0

SIZE	CODE	DOC. NUMBER	REV
A3	CS	Model No	A01

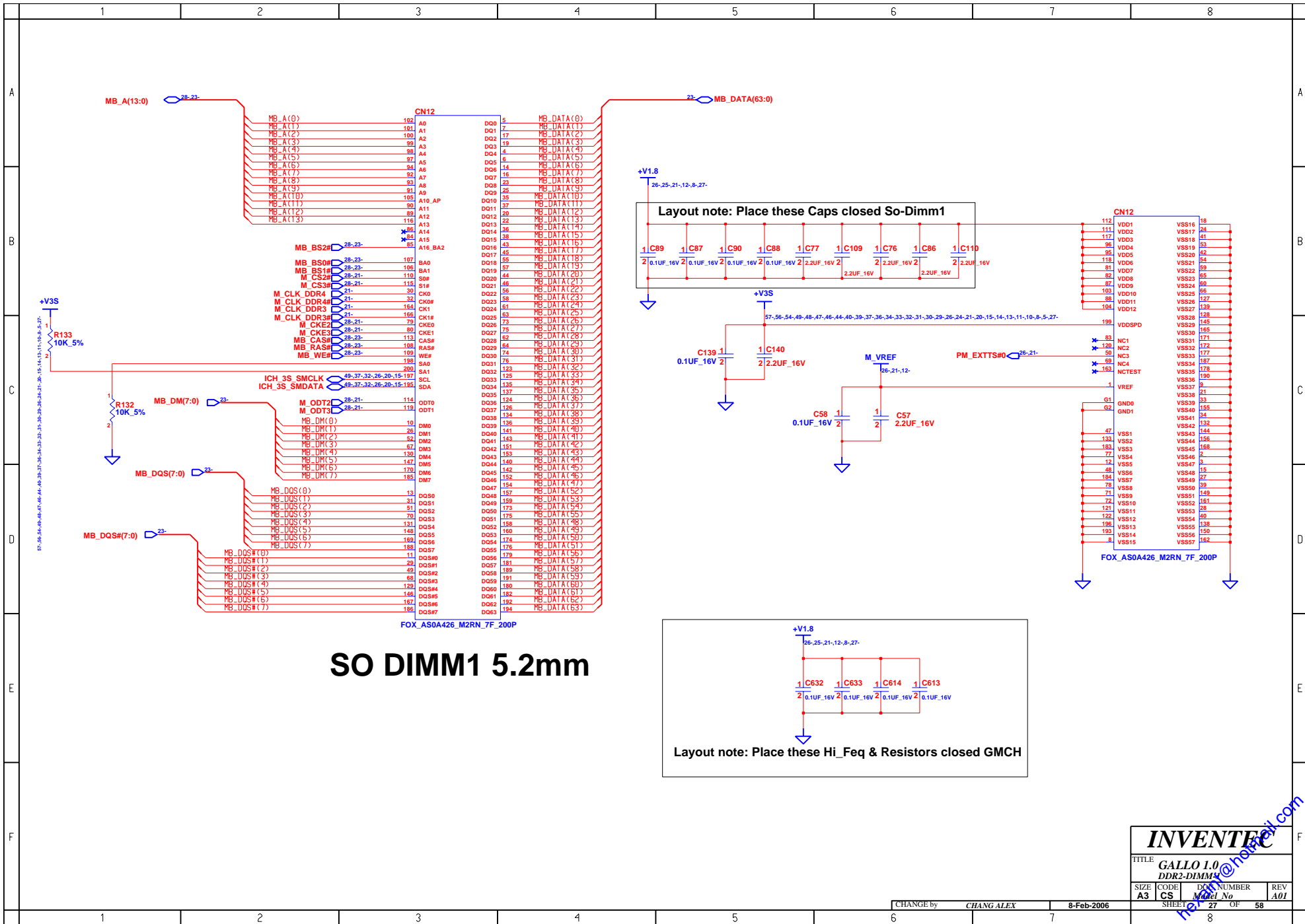

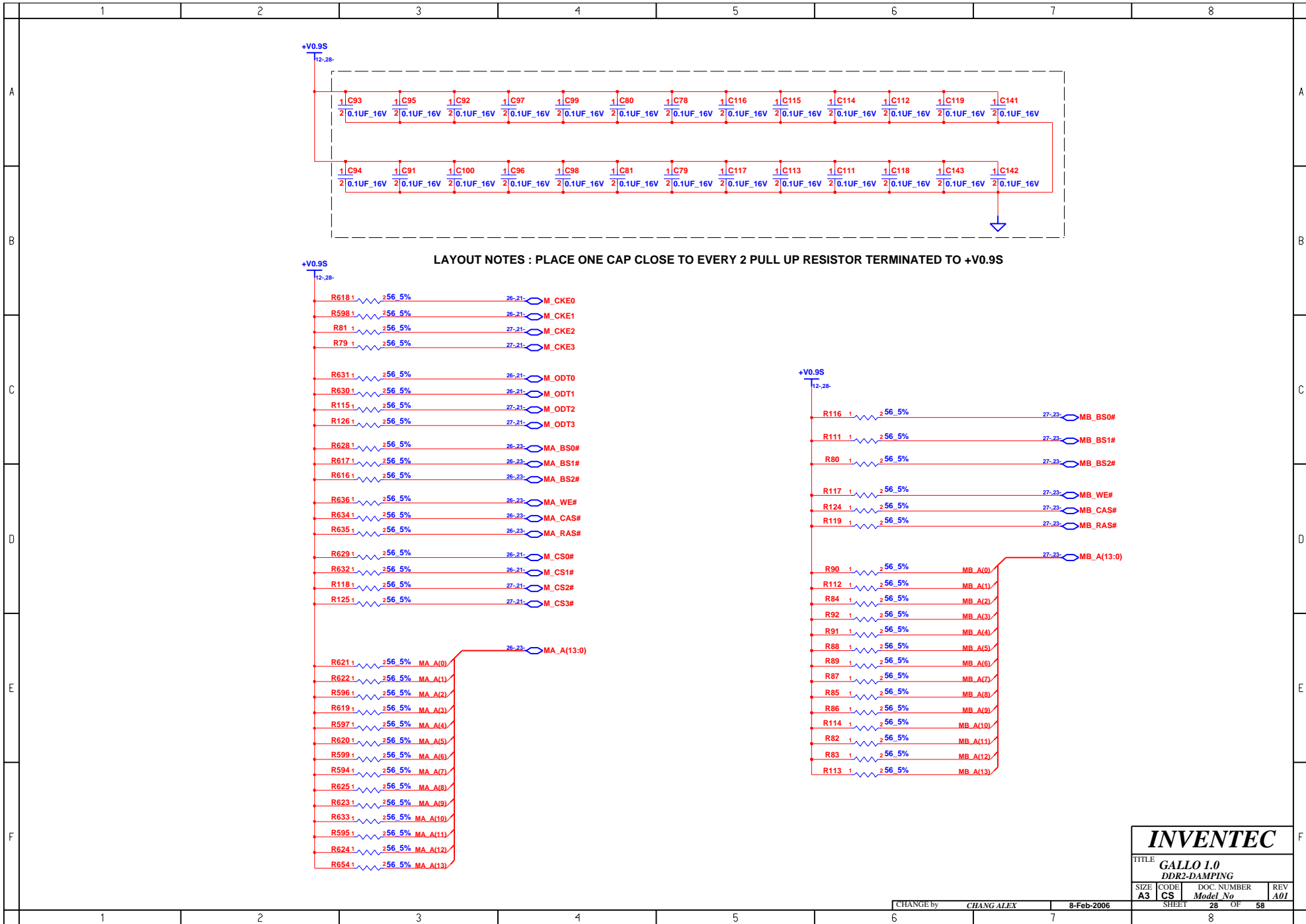

INVENTEC			
TITLE GALLO I.0			
DDR2-DAMPING			
SIZE	CODE	DOC. NUMBER	REV
A3	CS	Model No	A01
CHANGE by		8-Feb-2006	SHEET 28 OF 58
CHANG ALEX			

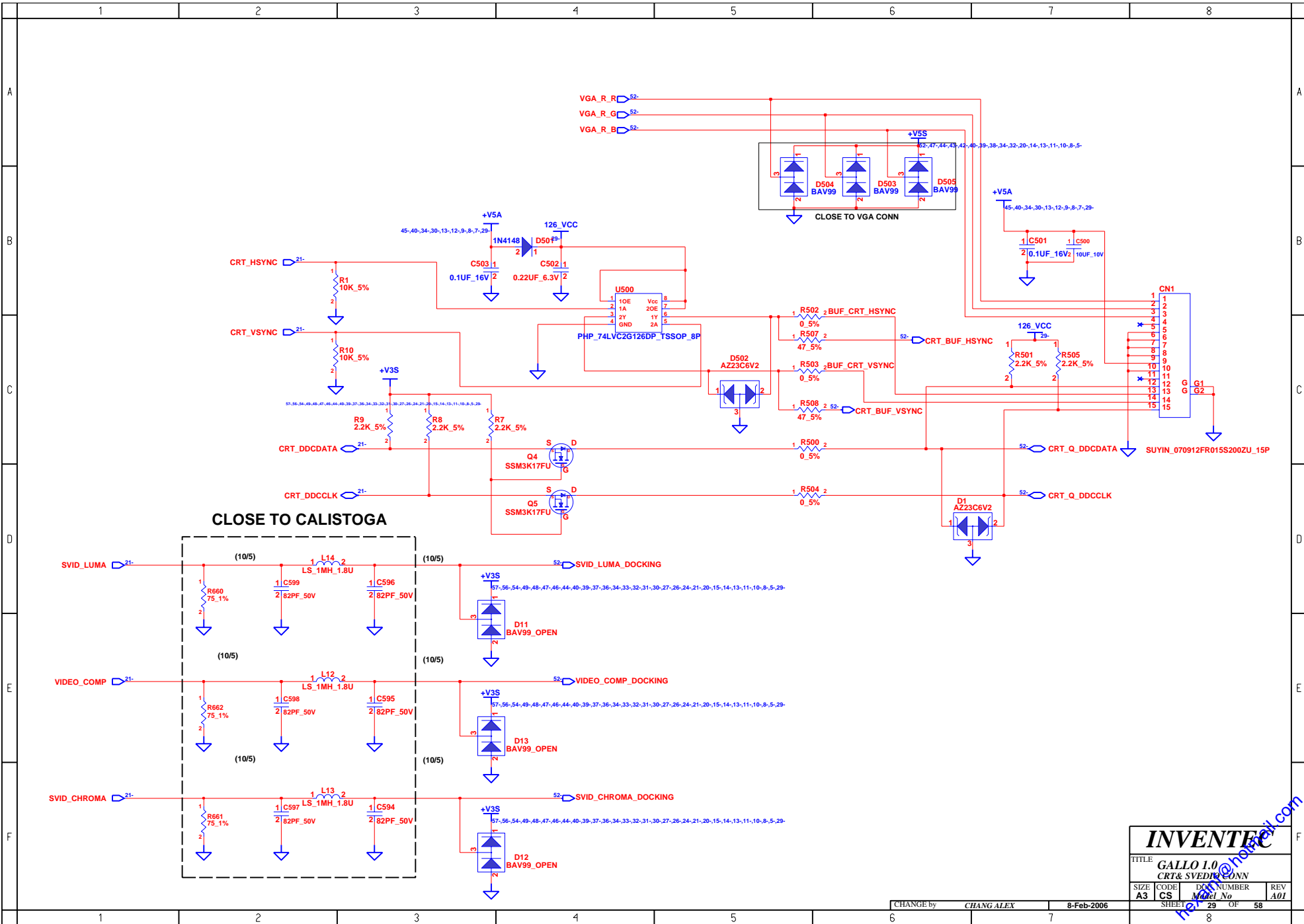

INVENTEC			
TITLE GALLO I.0 CRT & SVIDEO CONN			
SIZE A3	CODE CS	DOC NUMBER Model No	REV A01
CHANGE by CHANG ALEX		8-Feb-2006	
SHEET 29		OF 58	

Place closed to connector

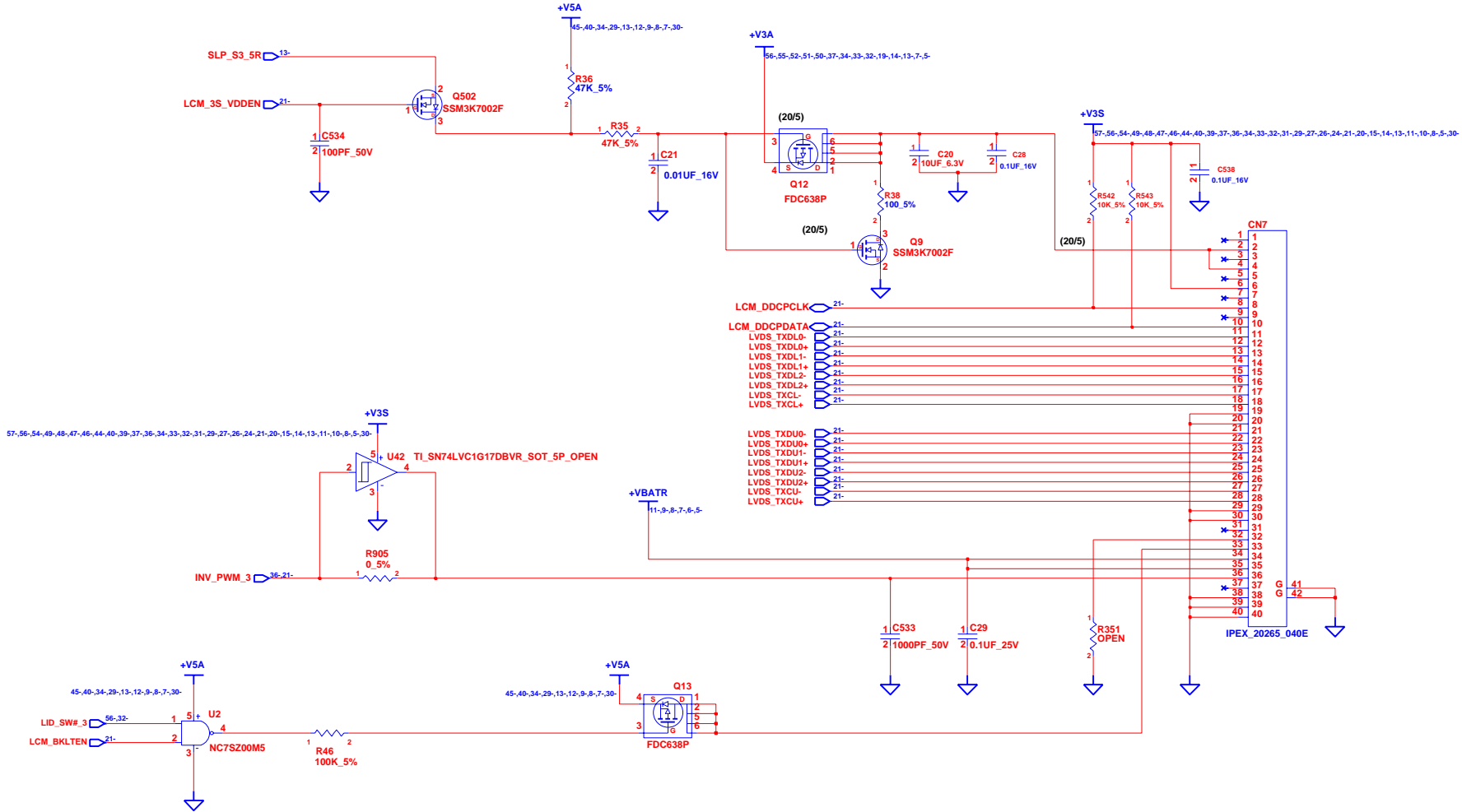

INVENTEC

TITLE
GALLO 1.0
 LCD CONN

SIZE A3	CODE CS	DOC. NUMBER <i>Model No</i>	REV A01
-------------------	-------------------	--------------------------------	-------------------

CHANGE by *CHANG ALEX* 8-Feb-2006 SHEET 30 OF 58

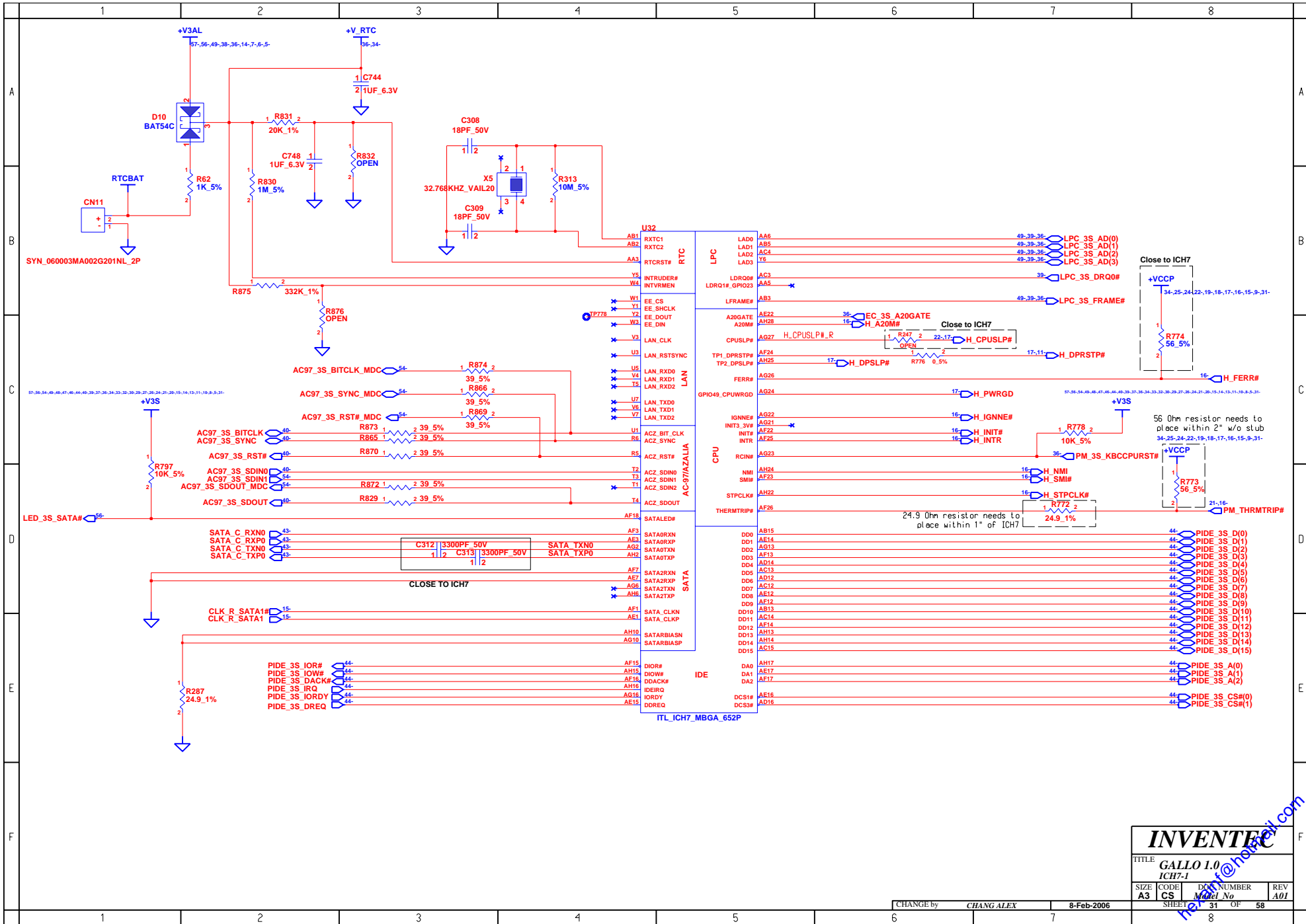

INVENTEC			
TITLE GALLO I.0 ICH7-1			
SIZE A3	CODE CS	DOC NUMBER Model No	REV A01
CHANGE by CHANG ALEX		8-Feb-2006	
SHEET 31		OF 58	

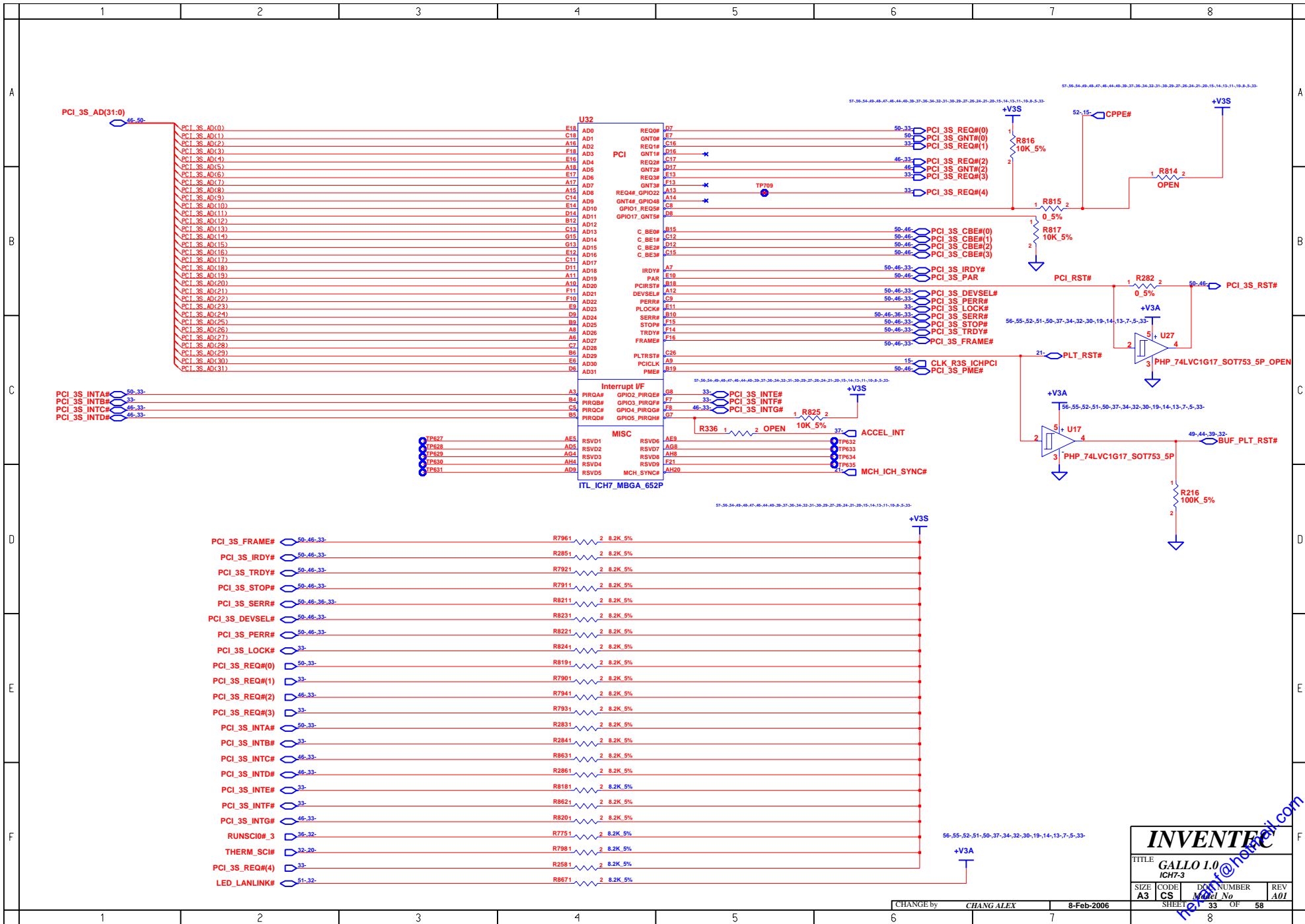

INVENTEC				
TITLE GALLO I.0 ICH7-3				
SIZE A3	CODE CS	DOC NUMBER Model No	REV A01	
SHEET 33 OF 58				

CHANGE by CHANG ALEX 8-Feb-2006

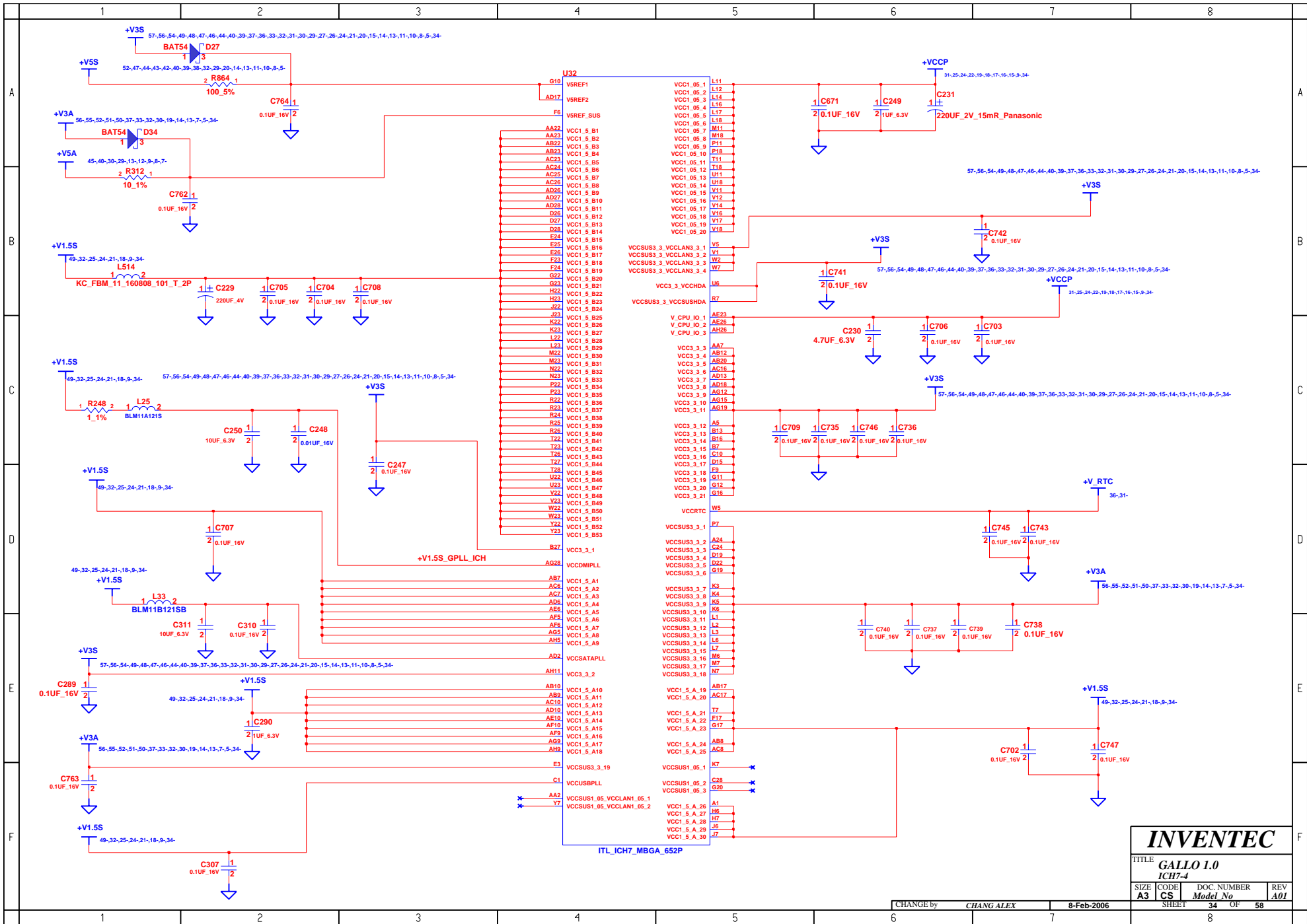

INVENTEC

TITLE: GALLO I.0 ICH7-4

SIZE	CODE	DOC. NUMBER	REV
A3	CS	Model No	A01

SHEET 34 OF 58

CHANGE by: CHANG ALEX 8-Feb-2006

	1	2	3	4	5	6	7	8	
A									A
B									B
C									C
D									D
E									E
F									F

U32

A4	VSS1	VSS98
A23	VSS2	VSS99
B1	VSS3	VSS100
B8	VSS4	VSS101
B11	VSS5	VSS102
B14	VSS6	VSS103
B17	VSS7	VSS104
B20	VSS8	VSS105
B26	VSS9	VSS106
B29	VSS10	VSS107
C2	VSS11	VSS108
C6	VSS12	VSS109
C27	VSS13	VSS110
D10	VSS14	VSS111
D13	VSS15	VSS112
D18	VSS16	VSS113
D21	VSS17	VSS114
D24	VSS18	VSS115
E1	VSS19	VSS116
E2	VSS20	VSS117
E4	VSS21	VSS118
E8	VSS22	VSS119
E15	VSS23	VSS120
F3	VSS24	VSS121
F4	VSS25	VSS122
F5	VSS26	VSS123
F12	VSS27	VSS124
F27	VSS28	VSS125
F28	VSS29	VSS126
G1	VSS30	VSS127
G2	VSS31	VSS128
G6	VSS32	VSS129
G6	VSS33	VSS130
G9	VSS34	VSS131
G14	VSS35	VSS132
G18	VSS36	VSS133
G21	VSS37	VSS134
G24	VSS38	VSS135
G25	VSS39	VSS136
G26	VSS40	VSS137
H3	VSS41	VSS138
H4	VSS42	VSS139
H5	VSS43	VSS140
H24	VSS44	VSS141
H27	VSS45	VSS142
H28	VSS46	VSS143
J1	VSS47	VSS144
J2	VSS48	VSS145
J5	VSS49	VSS146
J24	VSS50	VSS147
J25	VSS51	VSS148
J26	VSS52	VSS149
K24	VSS53	VSS150
K27	VSS54	VSS151
K28	VSS55	VSS152
L13	VSS56	VSS153
L15	VSS57	VSS154
L24	VSS58	VSS155
L25	VSS59	VSS156
L26	VSS60	VSS157
M3	VSS61	VSS158
M4	VSS62	VSS159
M5	VSS63	VSS160
M12	VSS64	VSS161
M13	VSS65	VSS162
M14	VSS66	VSS163
M15	VSS67	VSS164
M16	VSS68	VSS165
M17	VSS69	VSS166
M24	VSS70	VSS167
M27	VSS71	VSS168
M28	VSS72	VSS169
N1	VSS73	VSS170
N2	VSS74	VSS171
N5	VSS75	VSS172
N6	VSS76	VSS173
N11	VSS77	VSS174
N12	VSS78	VSS175
N13	VSS79	VSS176
N14	VSS80	VSS177
N15	VSS81	VSS178
N16	VSS82	VSS179
N17	VSS83	VSS180
N18	VSS84	VSS181
N24	VSS85	VSS182
N25	VSS86	VSS183
N26	VSS87	VSS184
P3	VSS88	VSS185
P4	VSS89	VSS186
P12	VSS90	VSS187
P13	VSS91	VSS188
P14	VSS92	VSS189
P15	VSS93	VSS190
P16	VSS94	VSS191
P17	VSS95	VSS192
P24	VSS96	VSS193
P27	VSS97	VSS194

ITL_ICH7_MBGA_652P



INVENTEC

TITLE GALLO 1.0
ICH7-5

SIZE	CODE	DOC NUMBER	REV
A3	CS	Model No	A01

SHEET 35 OF 58

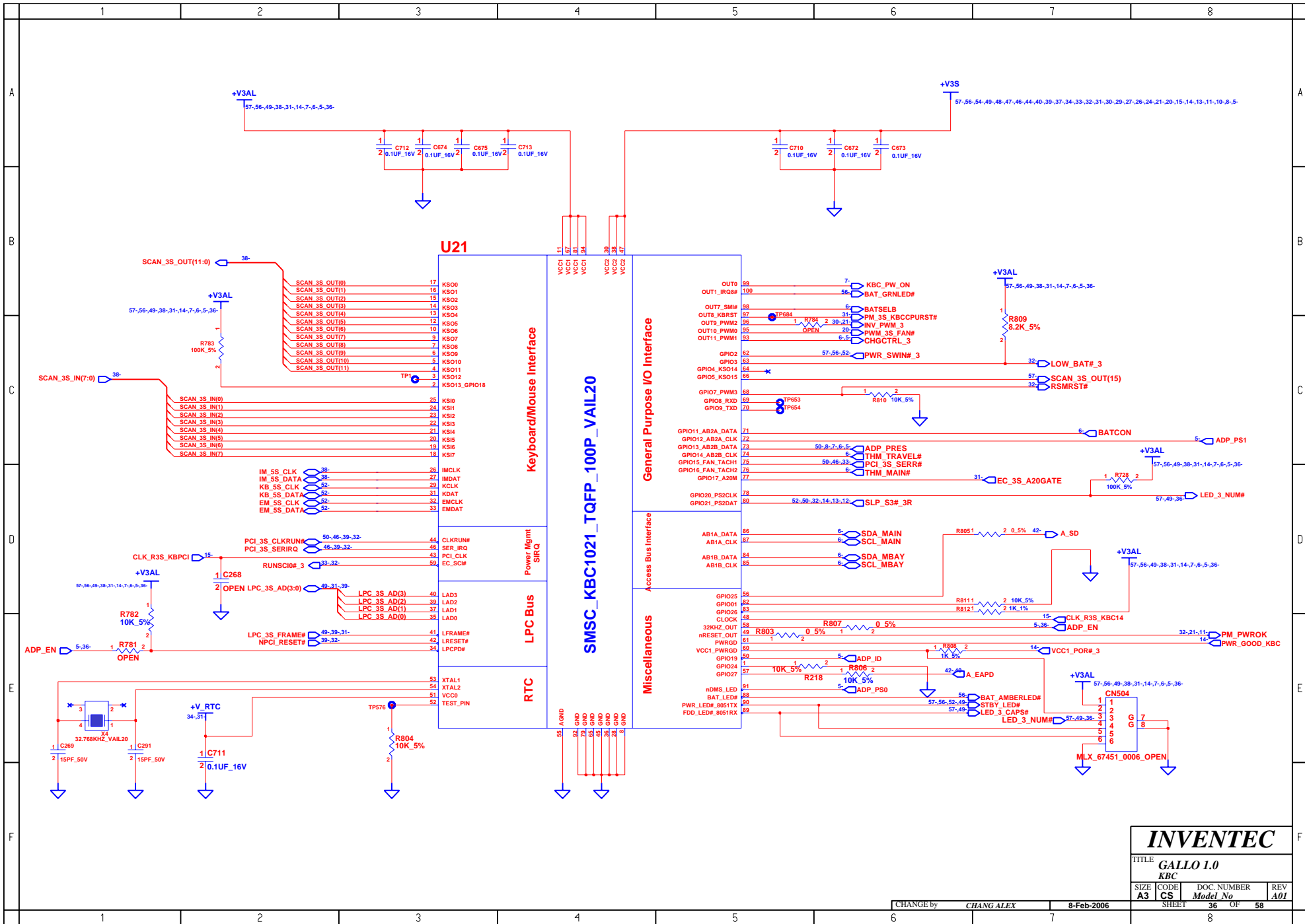

INVENTEC

TITLE			
GALLO I.0			
KBC			
SIZE	CODE	DOC. NUMBER	REV
A3	CS	Model No	A01

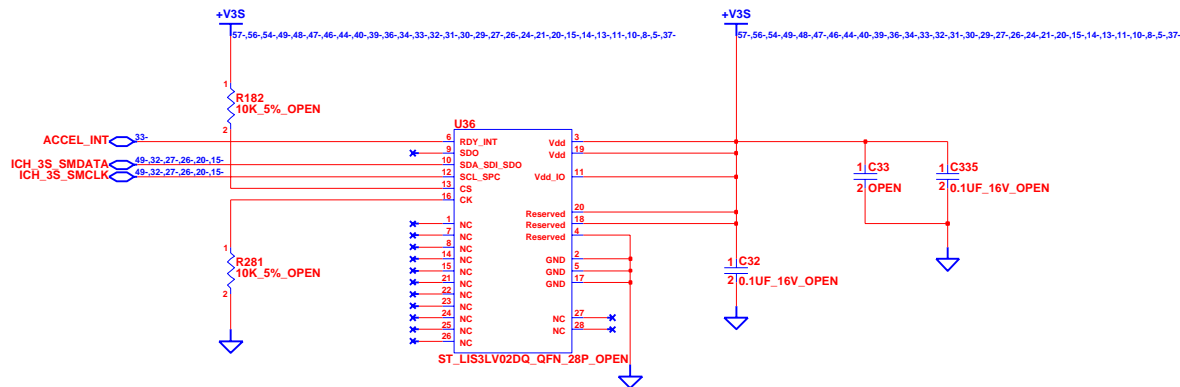

HARDDRIVE PROTECTION

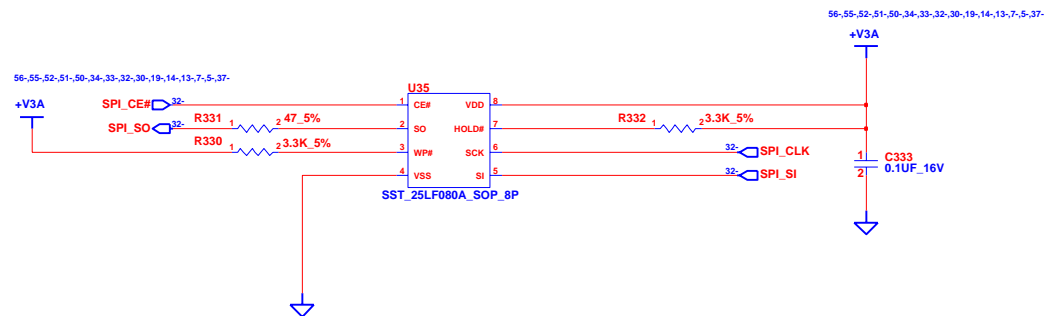

INVENTEC			
TITLE GALLO 1.0 SPI/HDD PROTECTION			
SIZE A3	CODE CS	DOC NUMBER Model No	REV A01
CHANGE by CHANG ALEX		8-Feb-2006	SHEET 37 OF 58

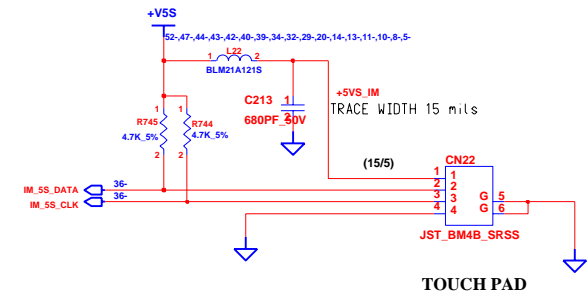
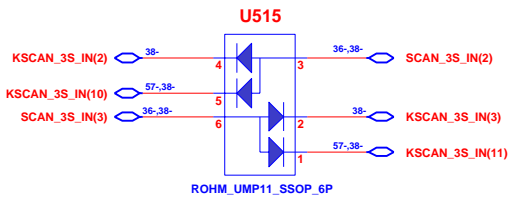
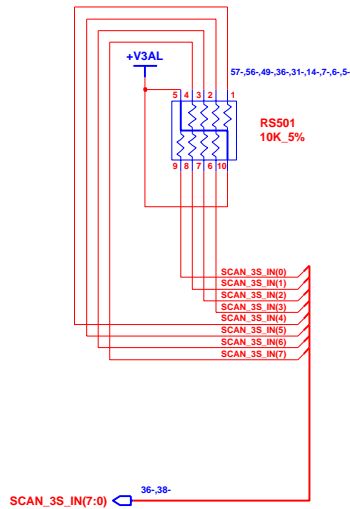
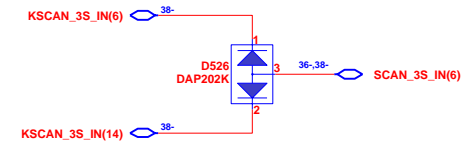
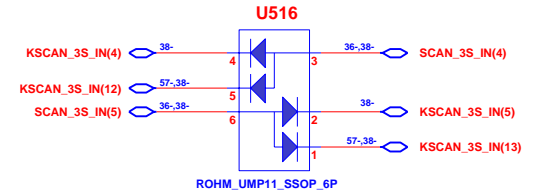
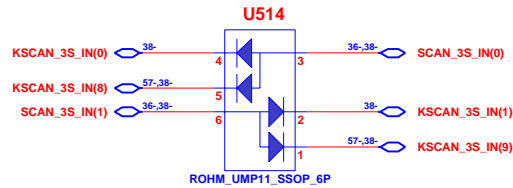
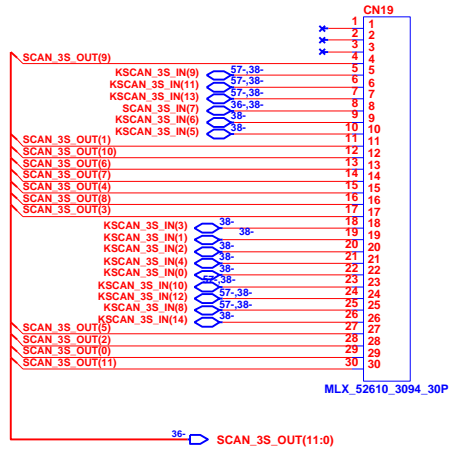

INVENTEC

TITLE			
GALLO 1.0			
INT.KBC/POINT DEVICES			
SIZE	CODE	DOC. NUMBER	REV
A3	CS	Model No	A01

CHANGE by CHANG ALEX 8-Feb-2006

SHEET 38 OF 58

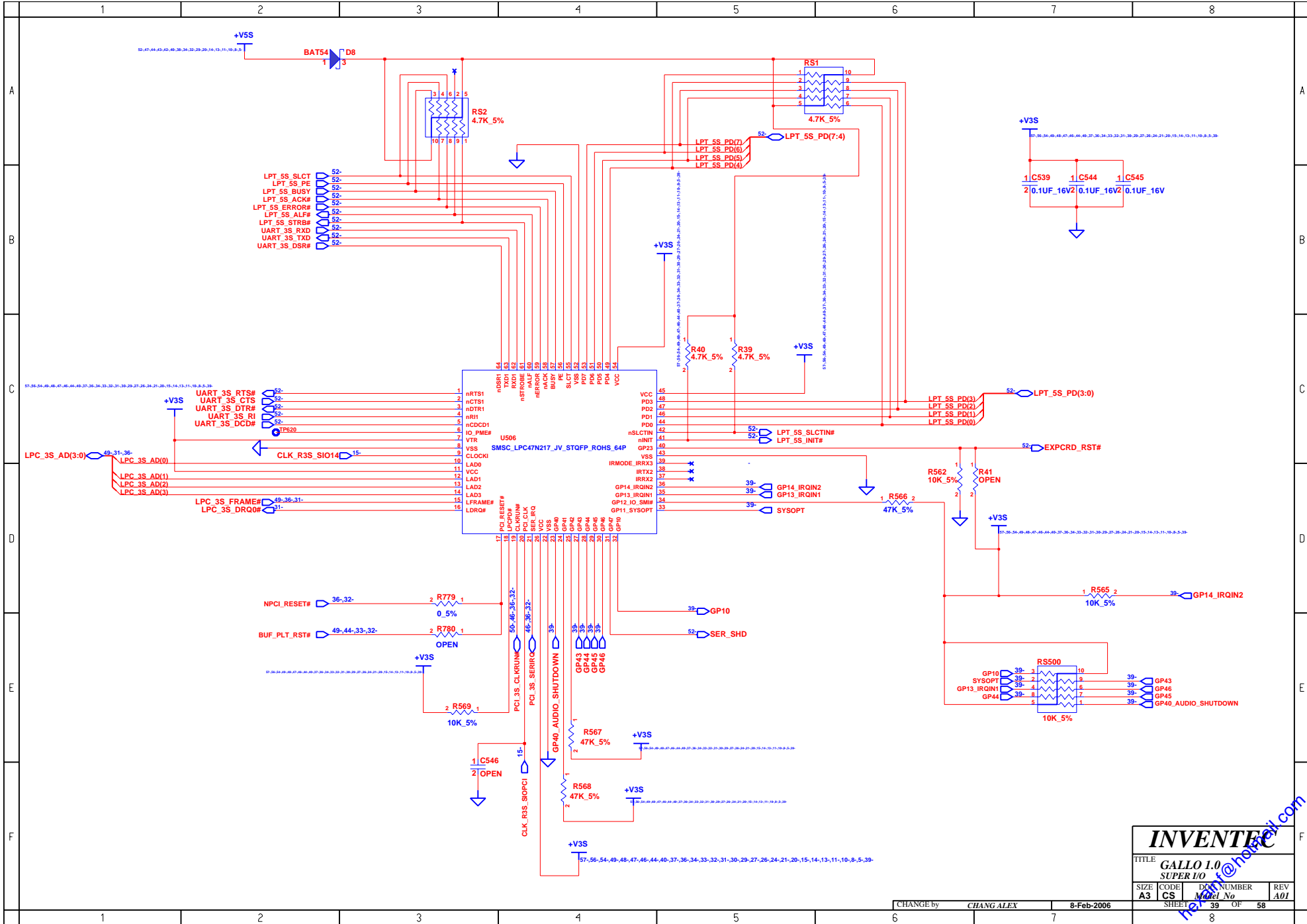

INVENTEC			
TITLE GALLO 1.0 SUPER I/O			
SIZE A3	CODE CS	DOC NUMBER <i>Model No</i>	REV A01
CHANGE by CHANG ALEX		8-Feb-2006	
SHEET 39		OF 58	

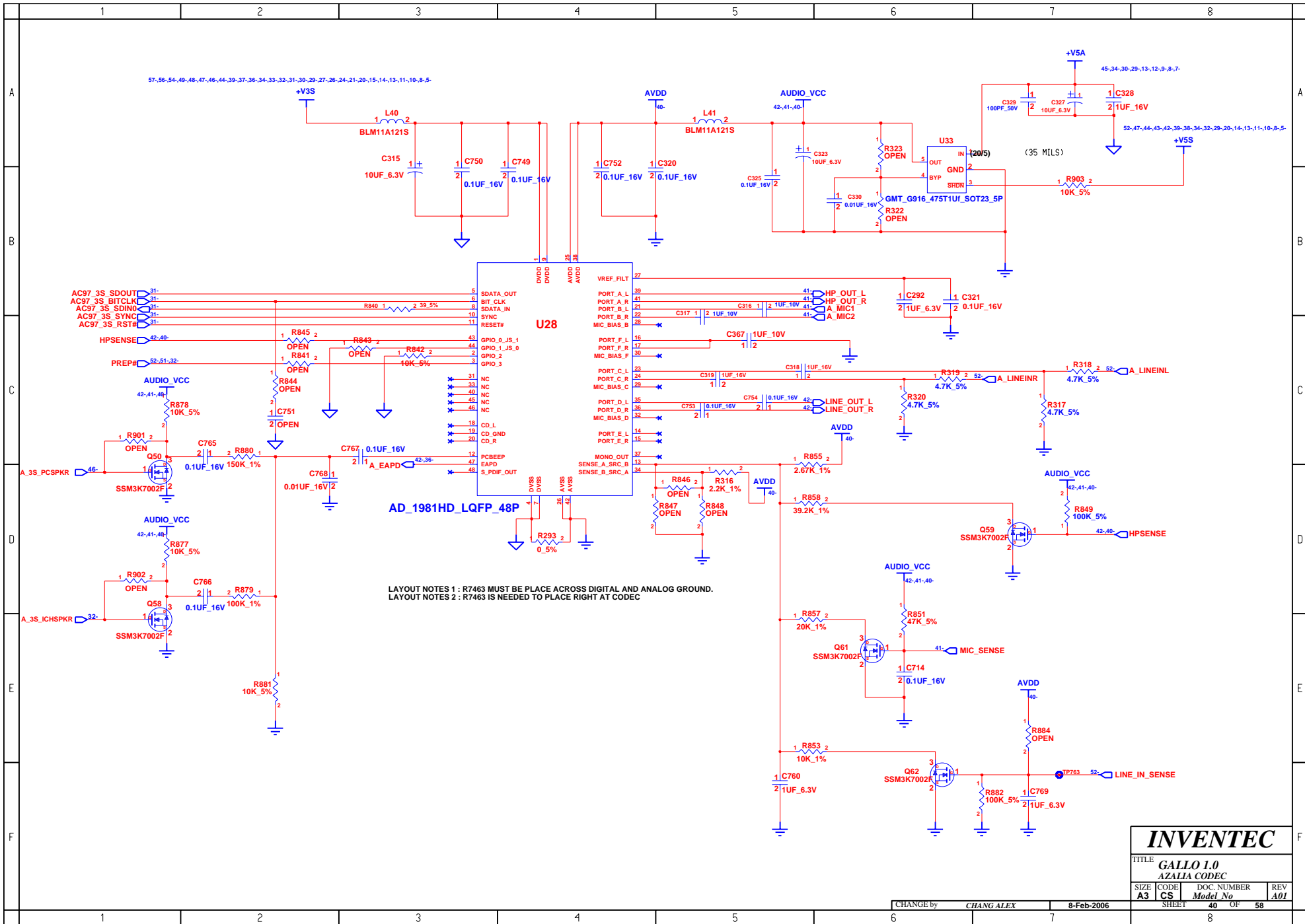

INVENTEC			
TITLE GALLO I.0 AZALIA CODEC			
SIZE A3	CODE CS	DOC. NUMBER <i>Model No</i>	REV A01
CHANGE by <i>CHANG ALEX</i>		8-Feb-2006	
SHEET 40		OF 58	

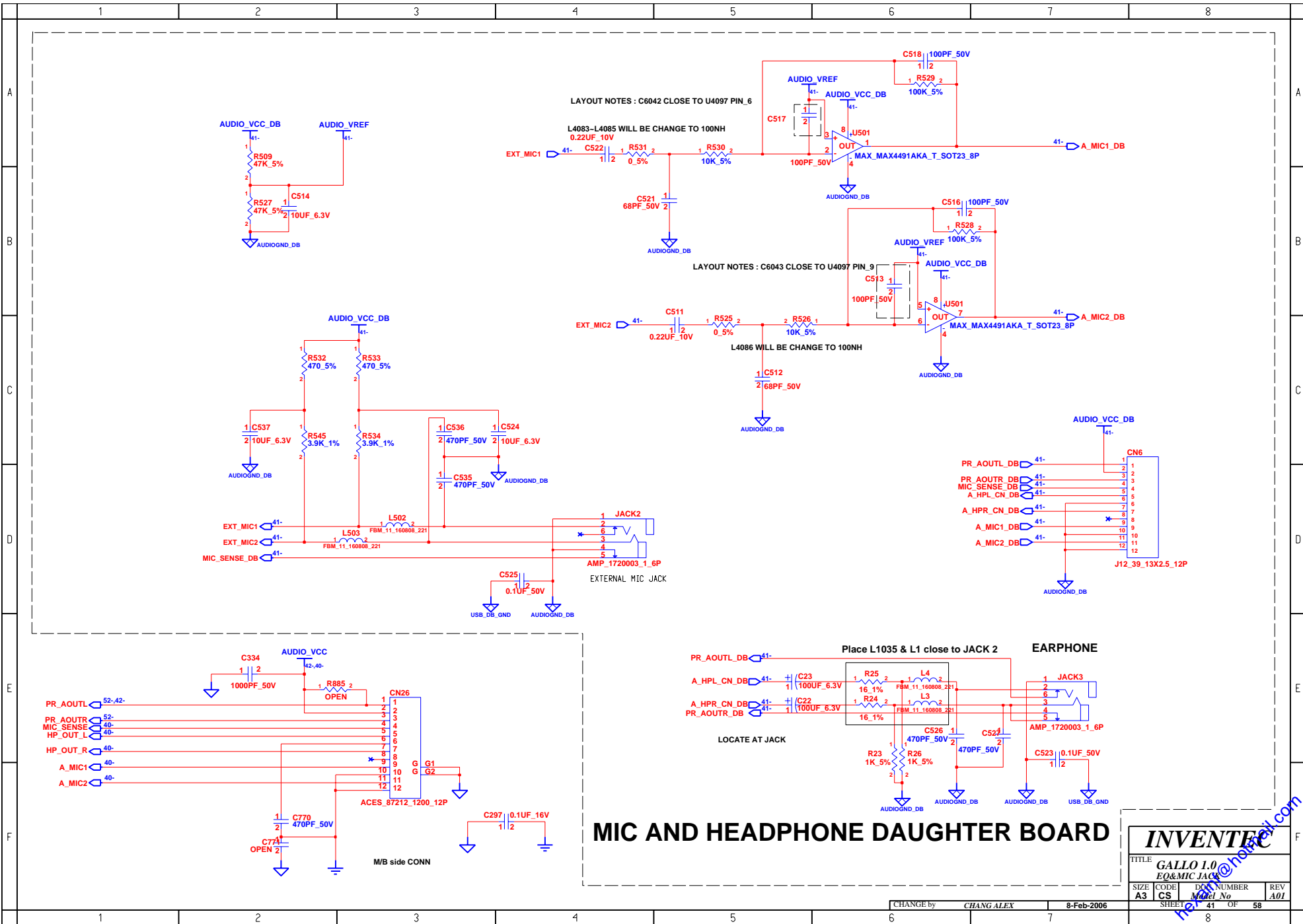

INVENTEC				
TITLE GALLO I.0 EQ&MIC JACK				
SIZE A3	CODE CS	DOC NUMBER Model No	REV A01	
CHANGE by CHANG ALEX		8-Feb-2006		
SHEET 41		OF 58		

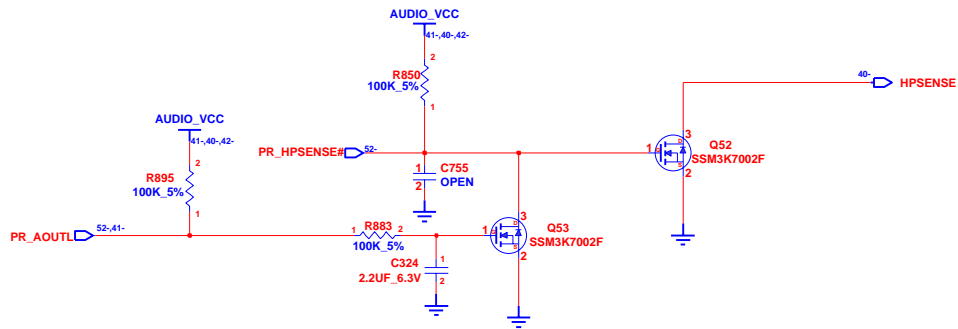
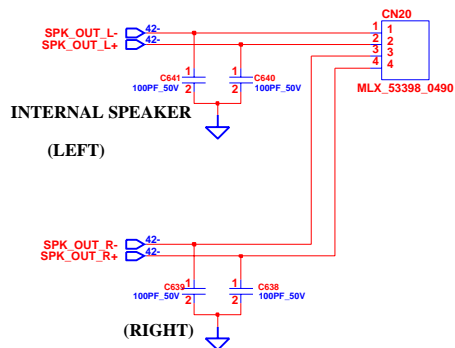
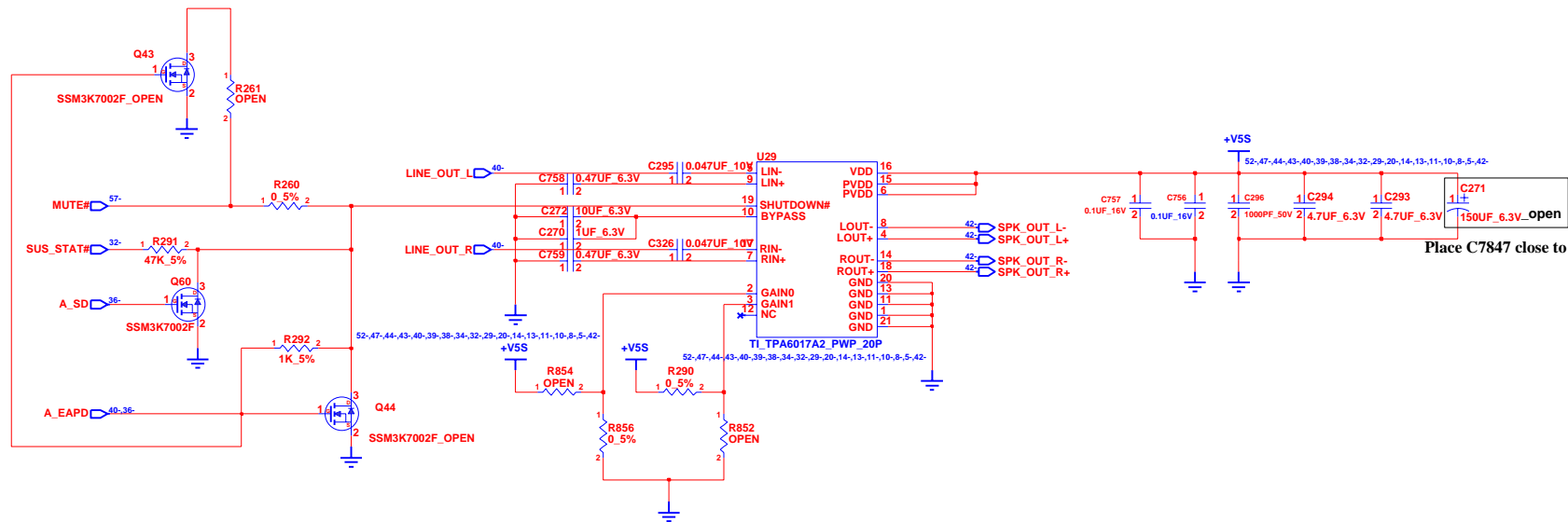

INVENTEC

TITLE			
GALLO I.0			
AUDIO AMP & HP JACK			
SIZE	CODE	DOC. NUMBER	REV
A3	CS	Model No	A01

CHANGE by CHANG ALEX 8-Feb-2006

SHEET 42 OF 58

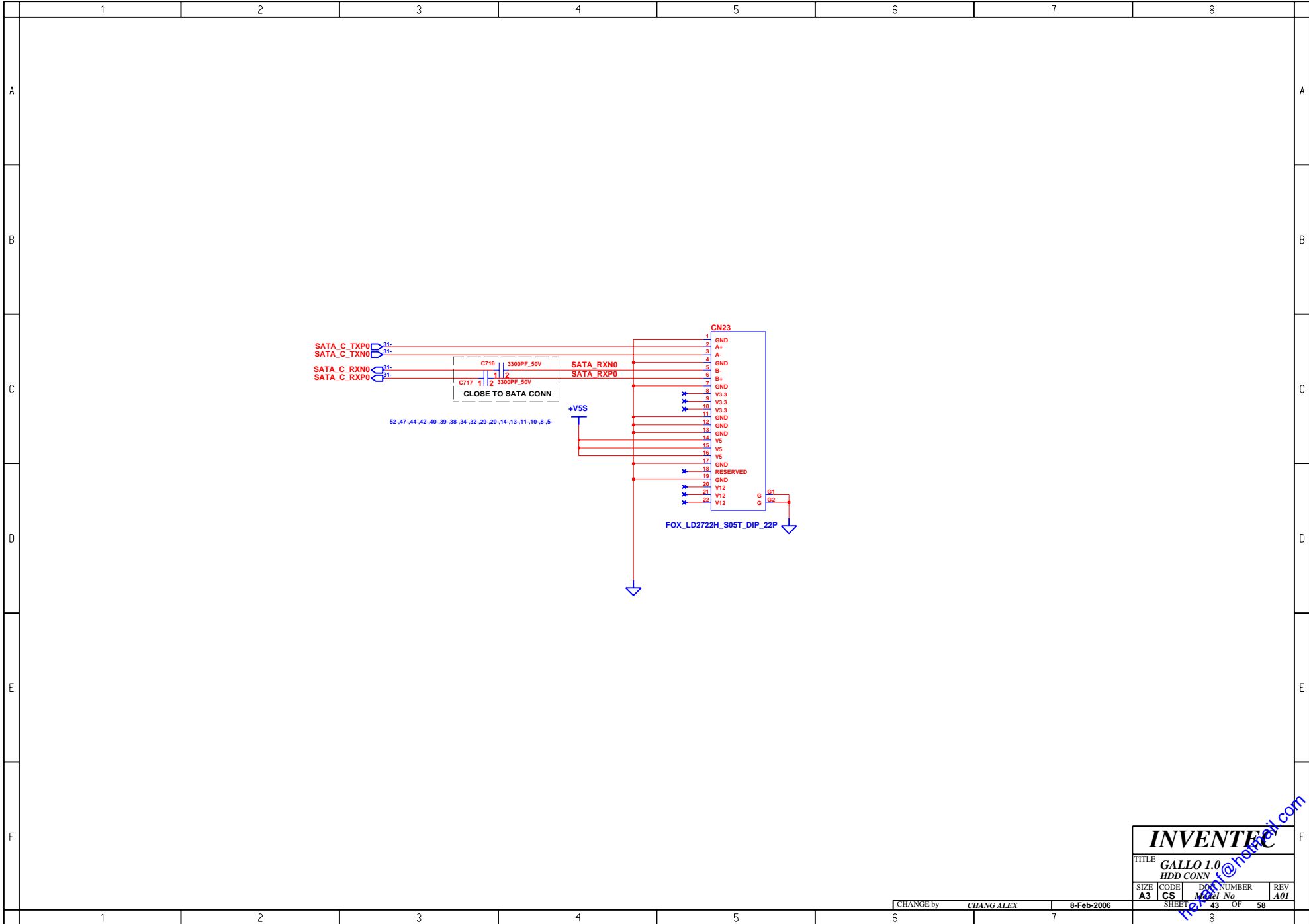

INVENTEC

TITLE **GALLO 1.0
HDD CONN**

SIZE A3	CODE CS	DOC NUMBER <i>Model No</i>	REV A01
-------------------	-------------------	-------------------------------	-------------------

CHANGE by **CHANG ALEX** 8-Feb-2006

SHEET 43 OF 58

net@inventec.com

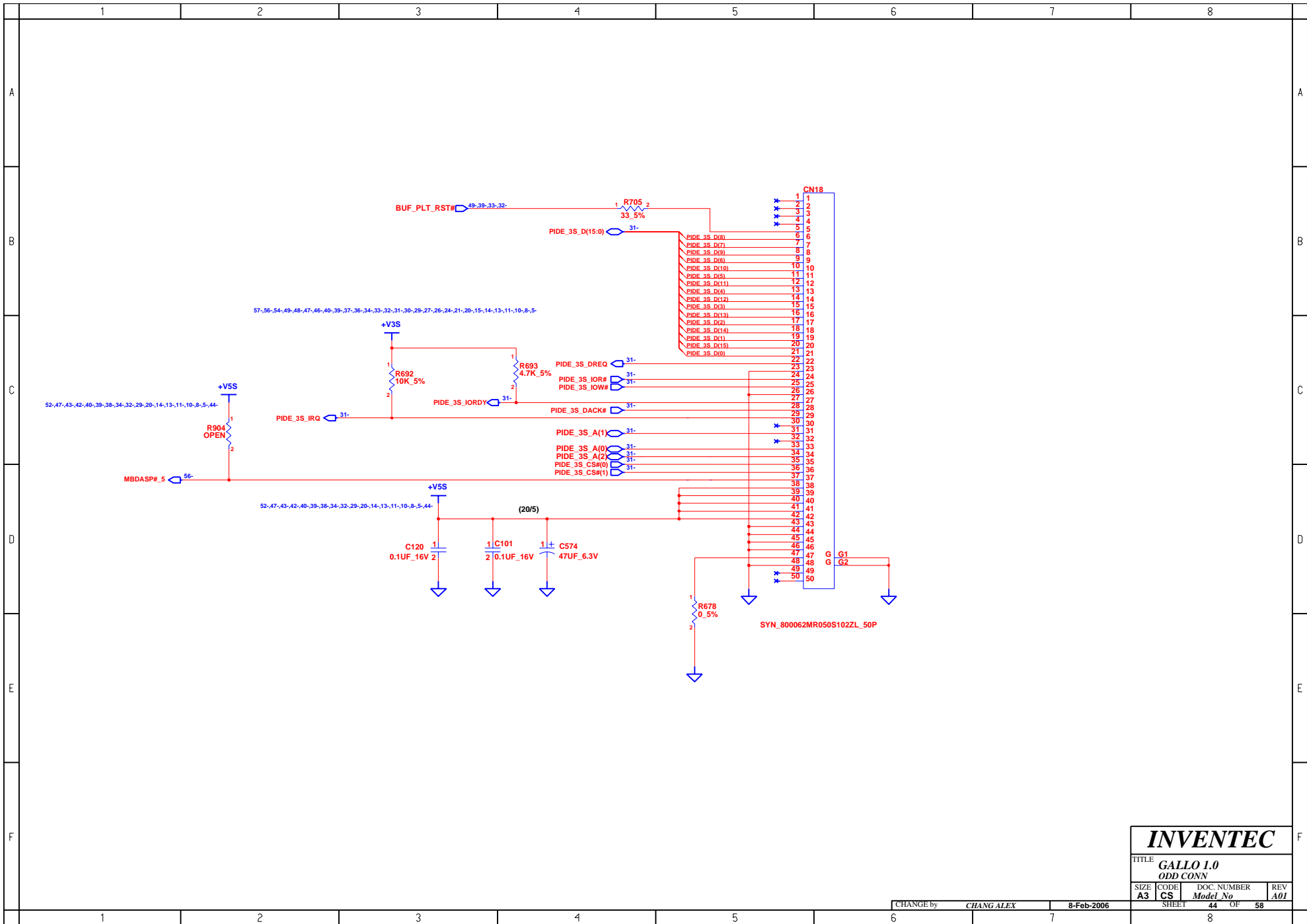

INVENTEC

TITLE **GALLO 1.0**
ODD CONN

SIZE	CODE	DOC. NUMBER	REV
A3	CS	Model No	A01

CHANGE by **CHANG ALEX** 8-Feb-2006

SHEET 44 OF 58

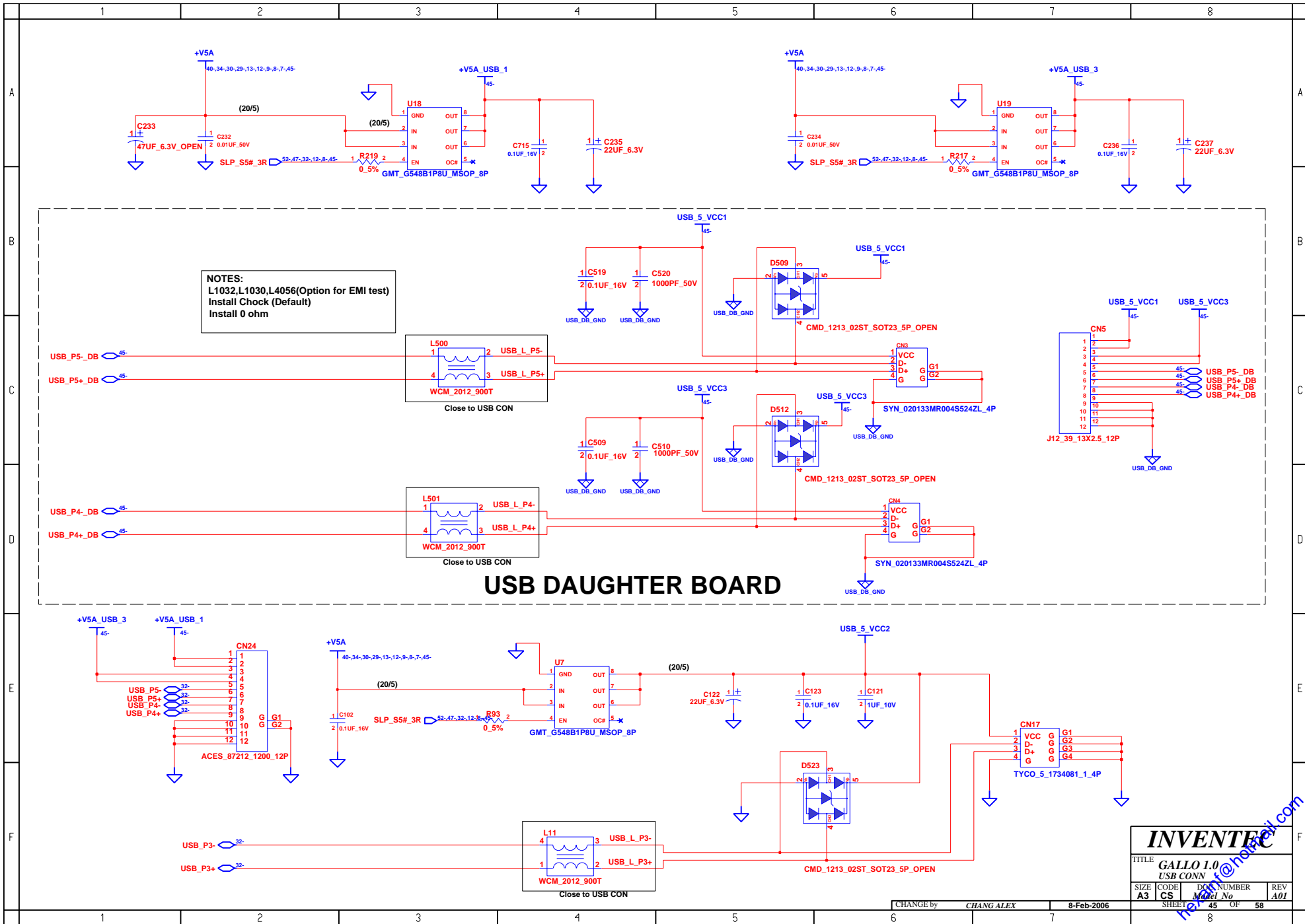

INVENTEC			
TITLE GALLO I.0 USB CONN			
SIZE A3	CODE CS	DOC NUMBER <i>Model No</i>	REV A01
CHANGE by <i>CHANG ALEX</i>		8-Feb-2006	
SHEET 45		OF 58	

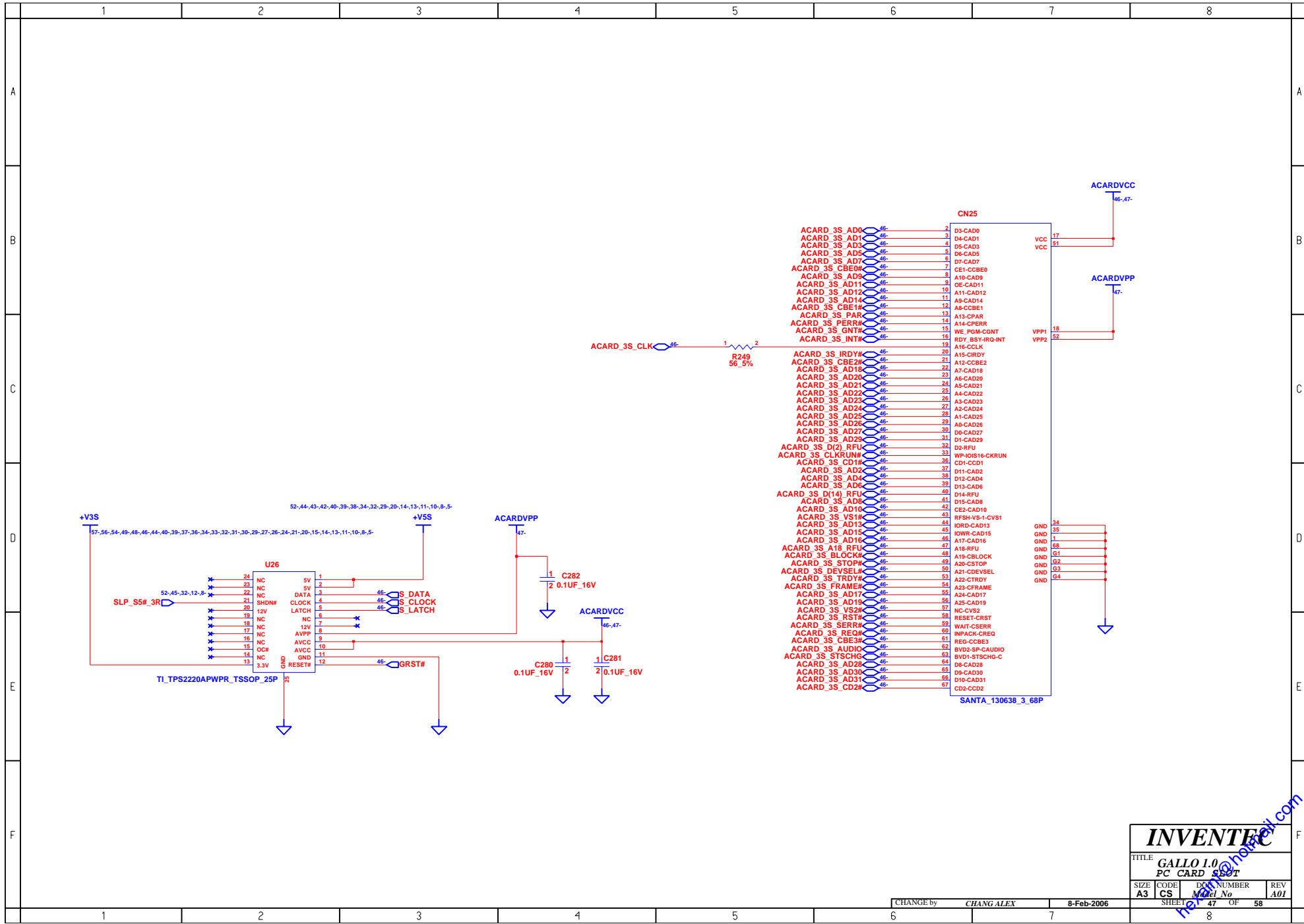

INVENTEC			
TITLE GALLO 1.0 PC CARD SET			
SIZE A3	CODE CS	DOC NUMBER Model No	REV A01
CHANGE by CHANG ALEX		8-Feb-2006	SHEET 47 OF 58

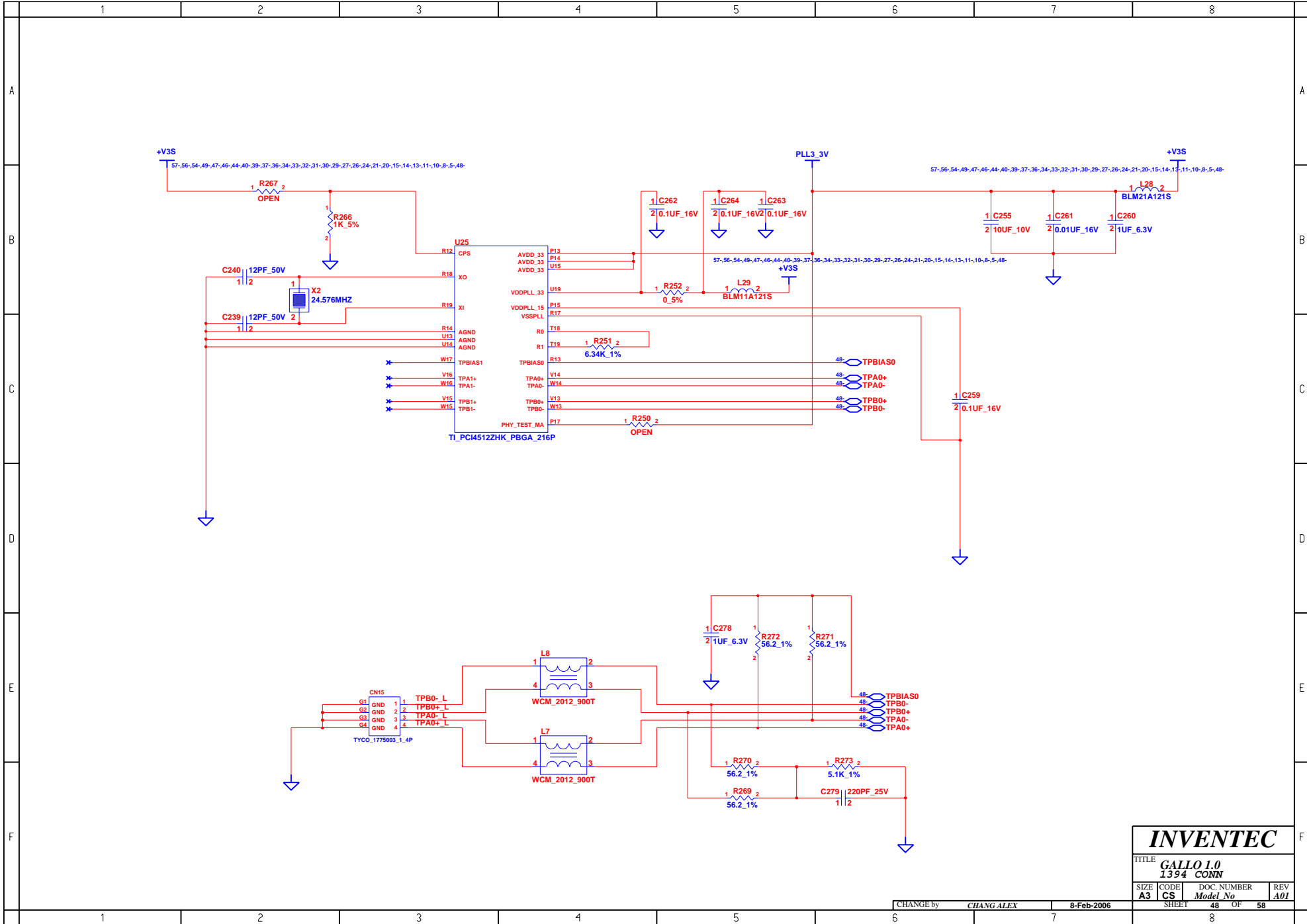

INVENTEC

TITLE
GALLO 1.0
1394_CONN

SIZE A3	CODE CS	DOC NUMBER Model No	REV A01
-------------------	-------------------	------------------------	-------------------

CHANGE by **CHANG ALEX** 8-Feb-2006 SHEET 48 OF 58

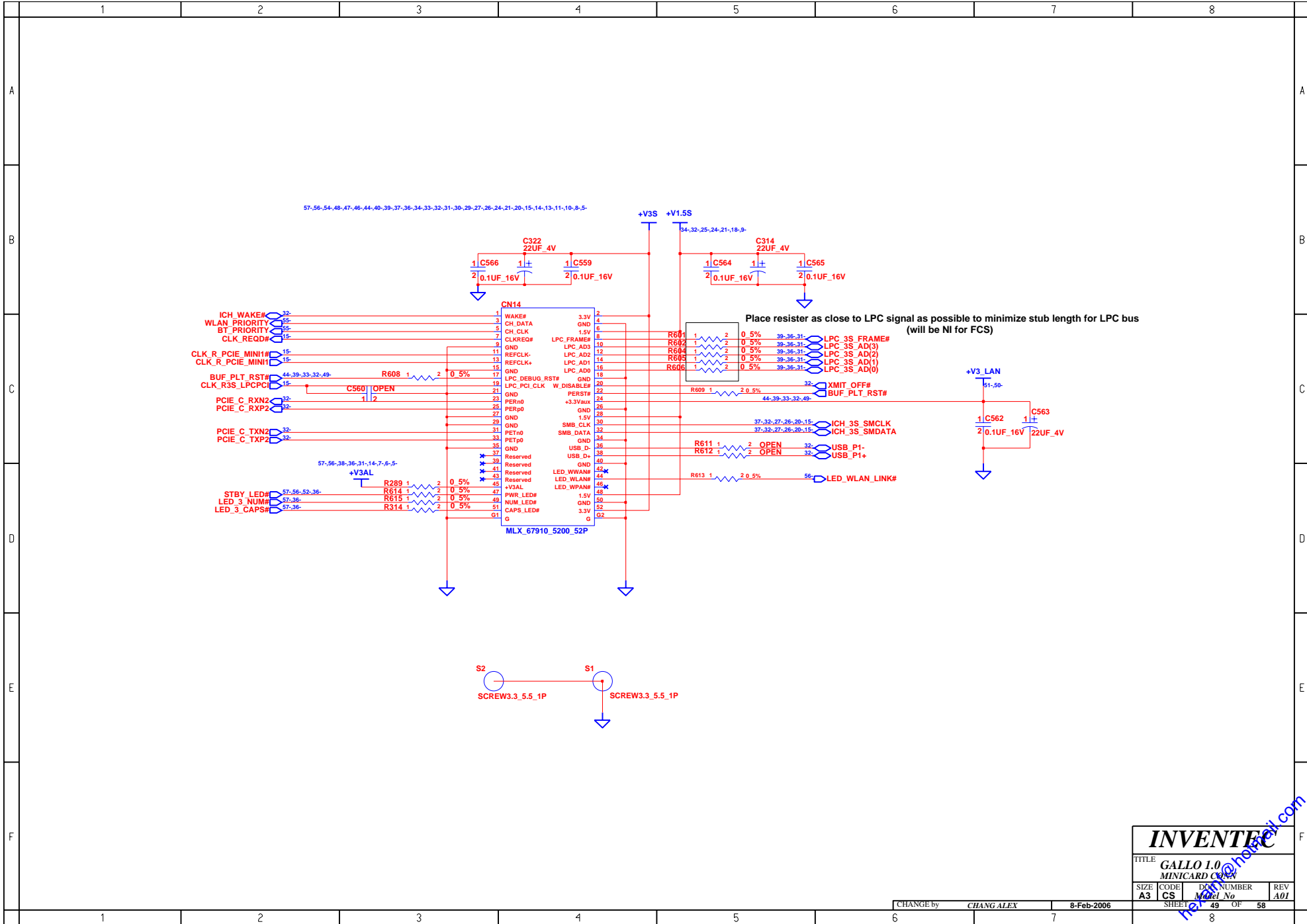

INVENTEC				
TITLE GALLO I.0 MINICARD CONN				
SIZE A3	CODE CS	DOC NUMBER Model No	REV A01	
CHANGE by		CHANG ALEX	8-Feb-2006	SHEET 49 OF 58

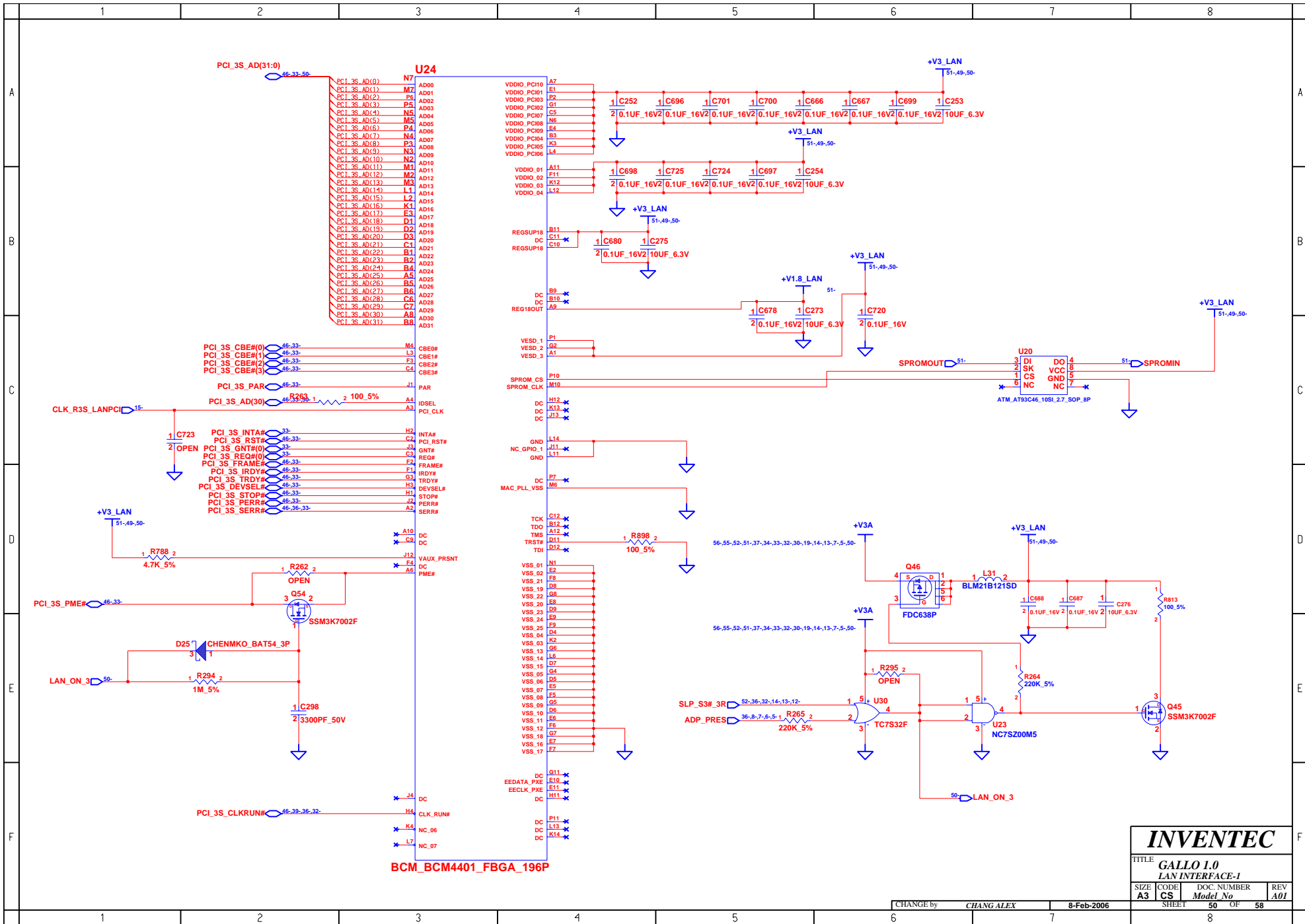

INVENTEC			
TITLE GALLO I.0 LAN INTERFACE-1			
SIZE A3	CODE CS	DOC. NUMBER Doc No	REV A01
CHANGE by CHANG ALEX		8-Feb-2006	
SHEET 50		OF 58	

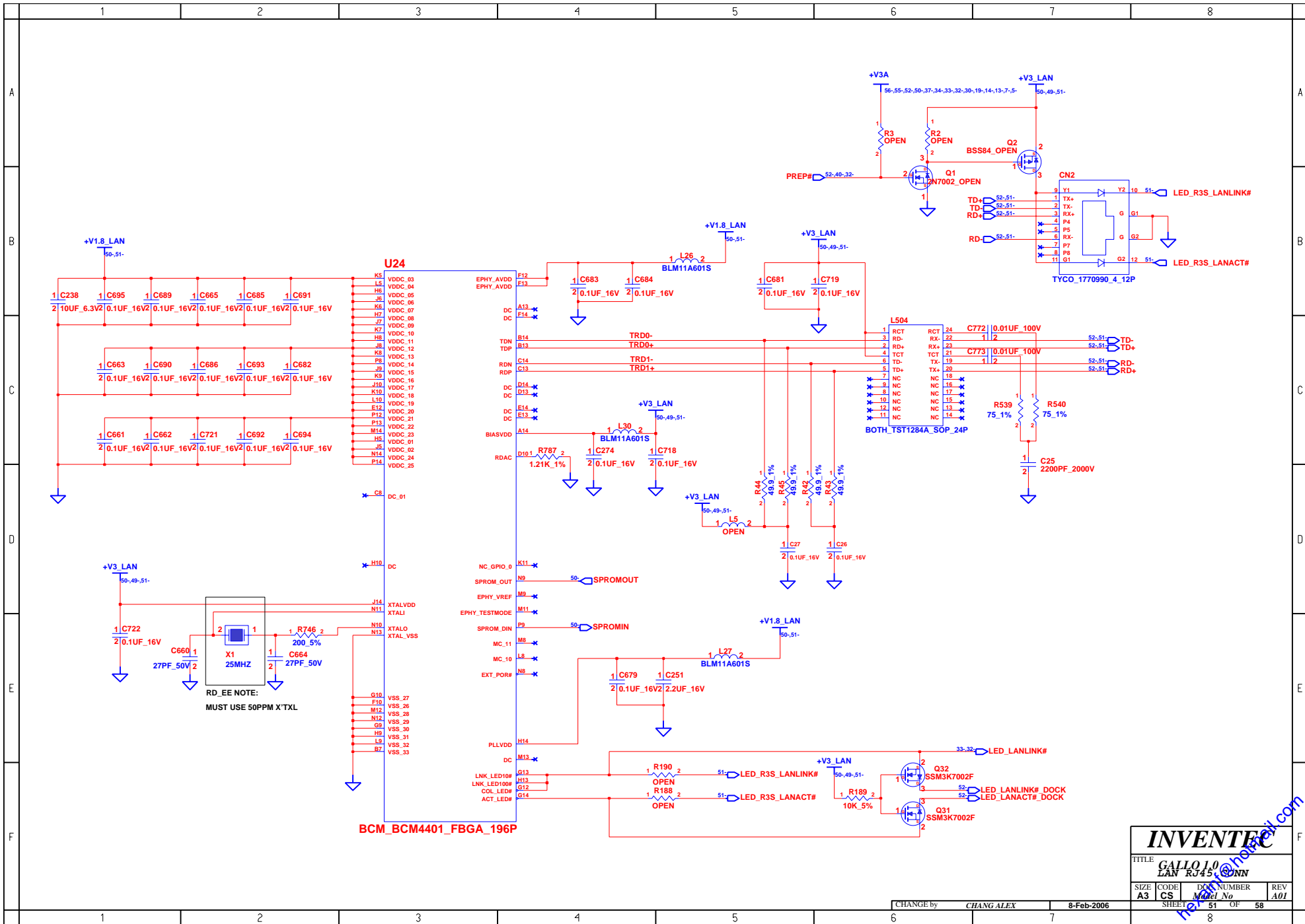

BCM BCM4401_FPGA_196P

RD_EE NOTE:
MUST USE 50PPM X'TXL

INVENTEC			
TITLE GALLO 10 LAN R345 @ CNN			
SIZE A3	CODE CS	DOC NUMBER Model No	REV A01
CHANGE by CHANG ALEX		8-Feb-2006	
SHEET 51		OF 58	

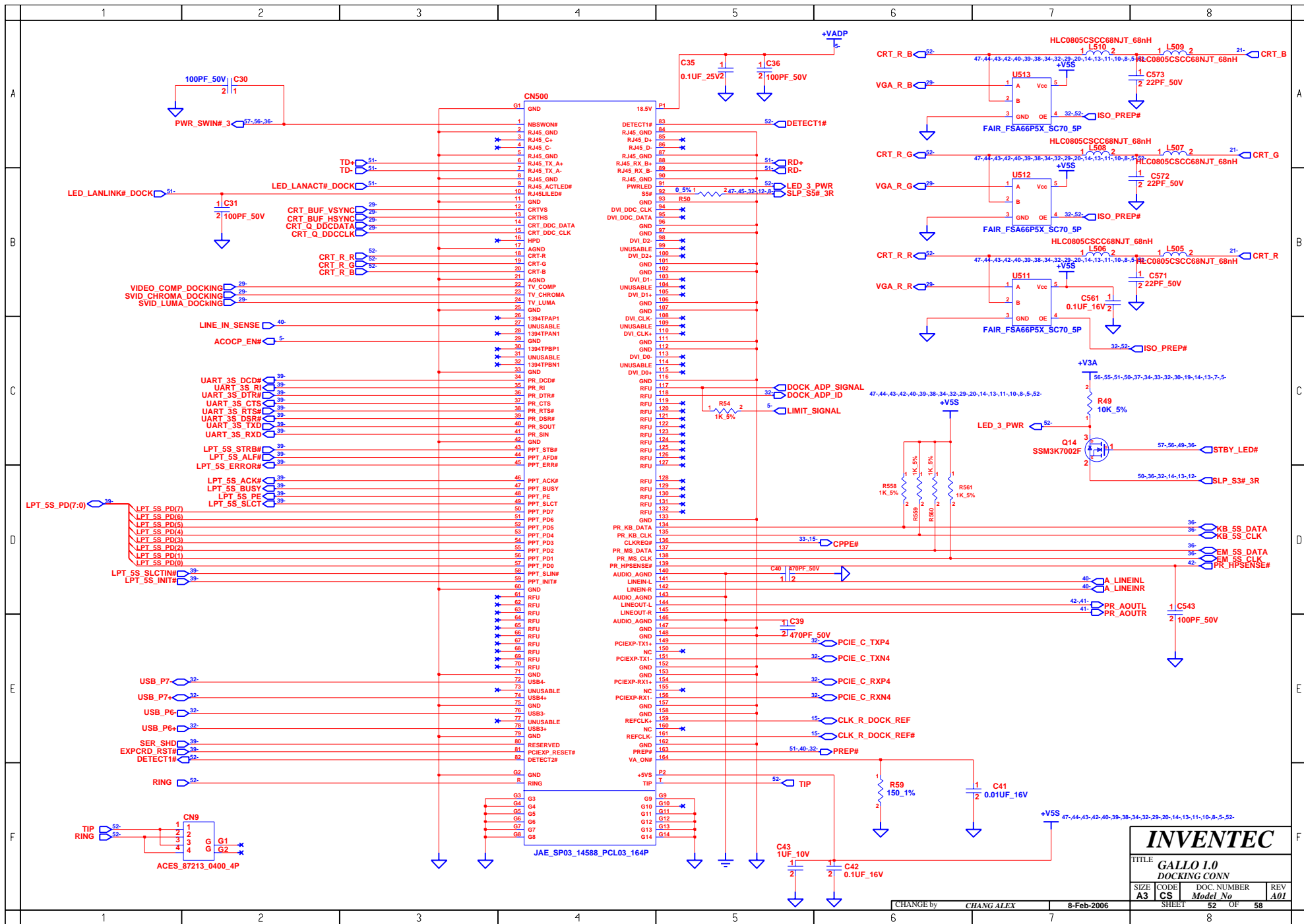

INVENTEC

TITLE
GALLO I.0
DOCKING CONN

SIZE A3	CODE CS	DOC NUMBER Doc No	REV A01
------------	------------	----------------------	------------

SHEET 52 OF 58

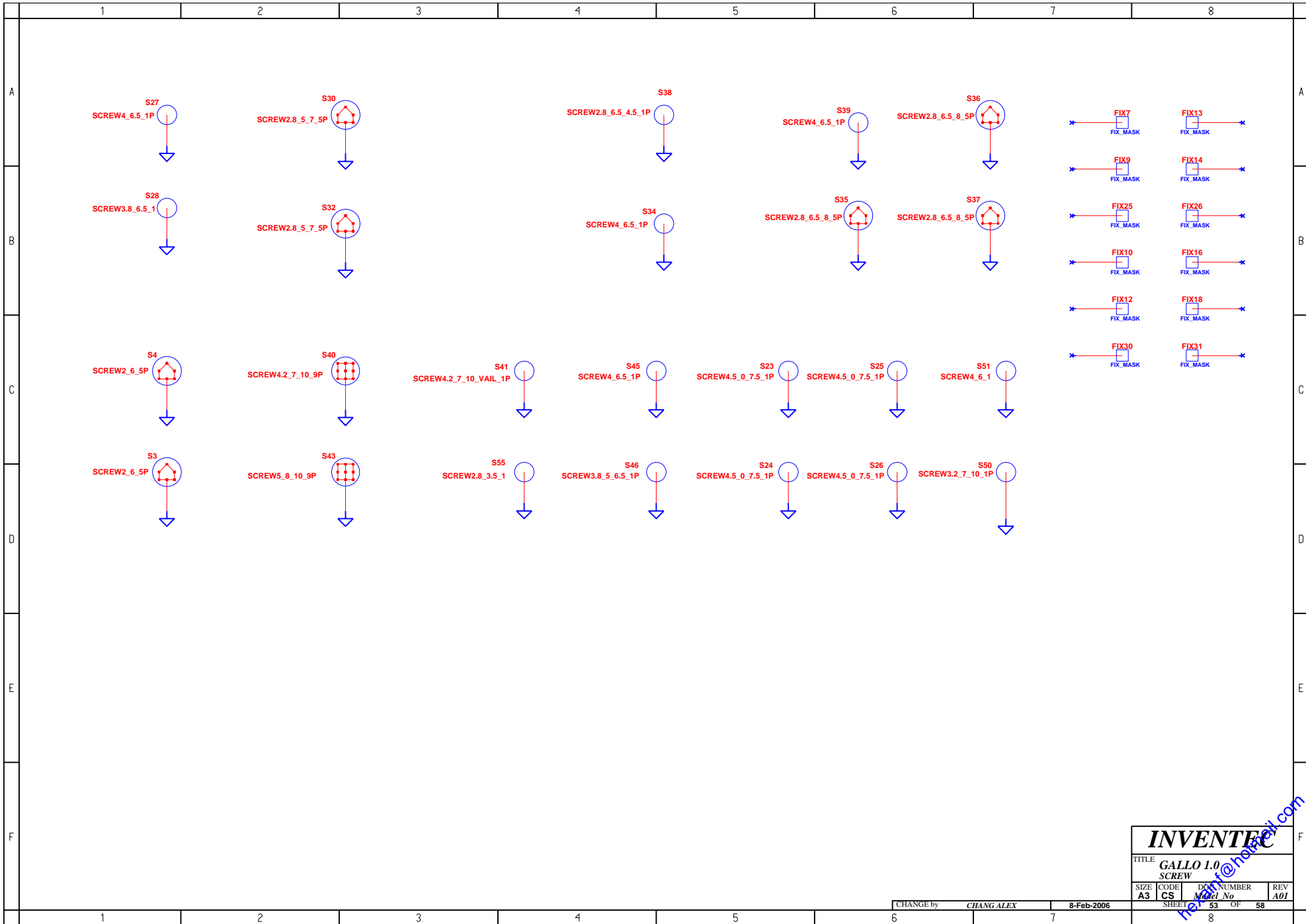

INVENTEC			
TITLE GALLO 1.0 SCREW			
SIZE A3	CODE CS	DOC NUMBER Model No	REV A01

CHANGE by CHANG ALEX 8-Feb-2006

SHEET 53 OF 58

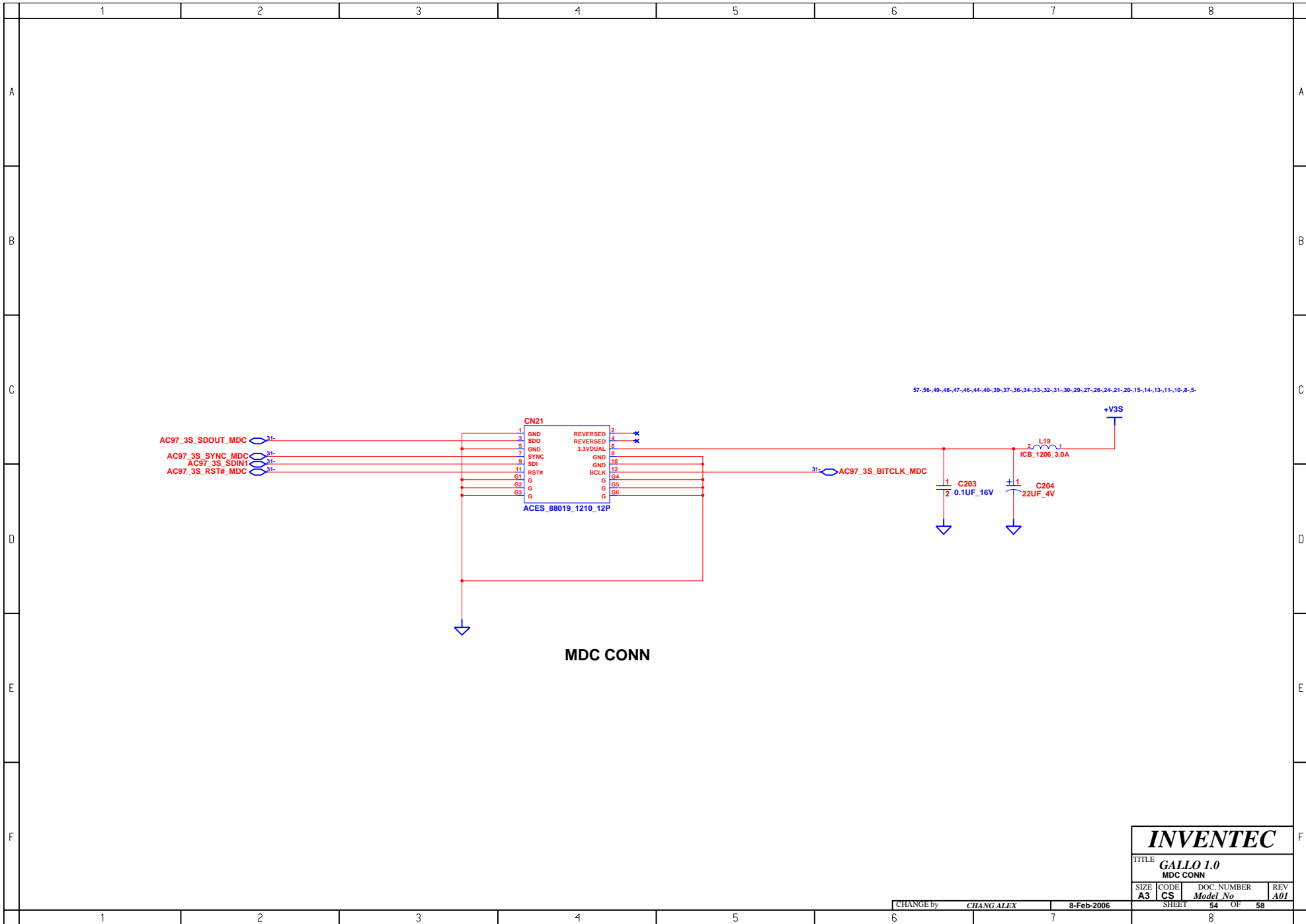

MDC CONN

INVENTEC			
TITLE GALLO 1.0			
MDC CONN			
SIZE	CODE	DOC. NUMBER	REV
A3	CS	Model No	A01
CHANGE by		8-Feb-2006	SHEET 54 OF 58
1	2	7	8

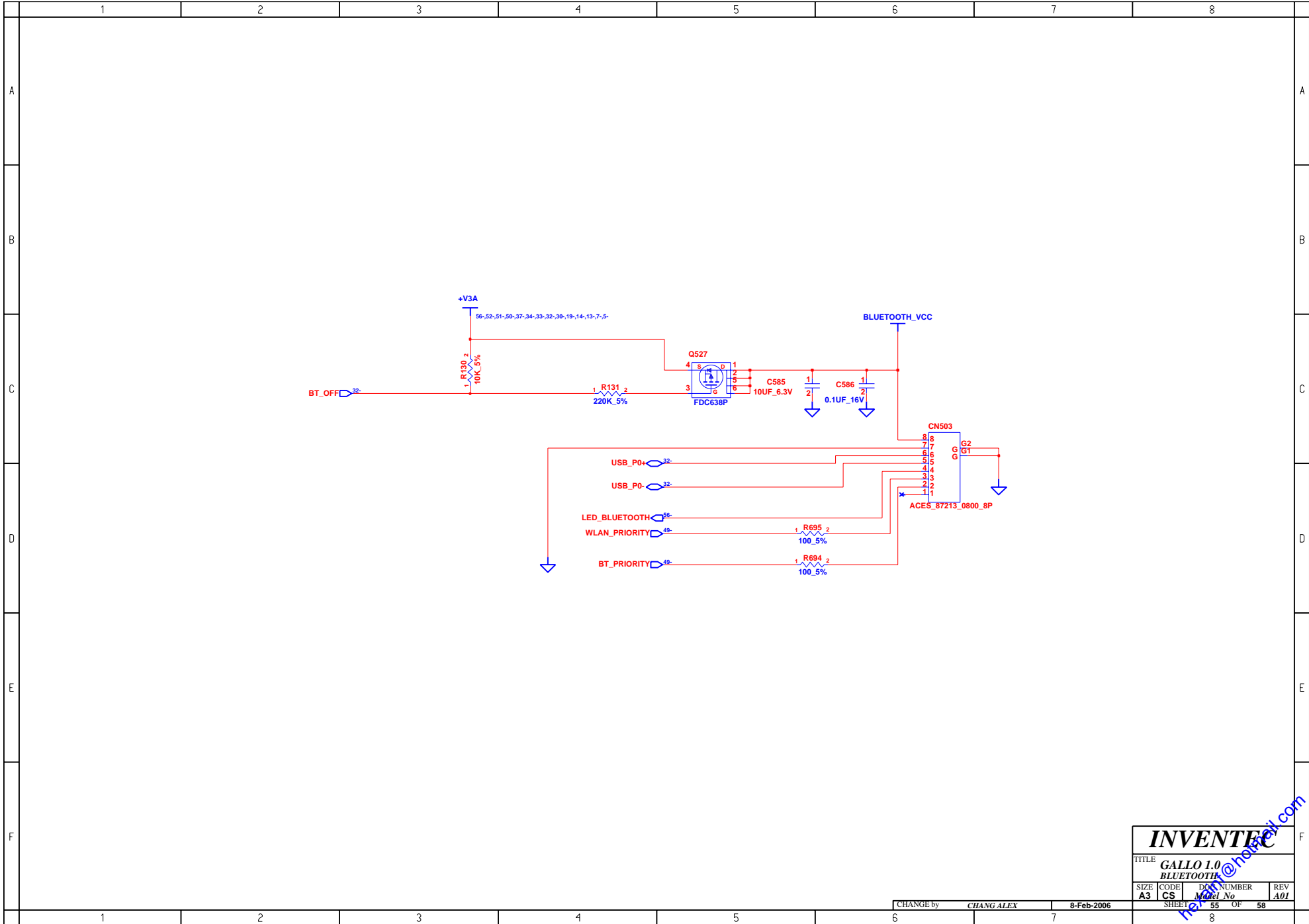

INVENTEC

TITLE **GALLO 1.0
BLUETOOTH**

SIZE A3	CODE CS	DOC NUMBER Model No	REV A01
-------------------	-------------------	------------------------	-------------------

CHANGE by **CHANG ALEX** 8-Feb-2006

SHEET 55 OF 58

net@inventec.com

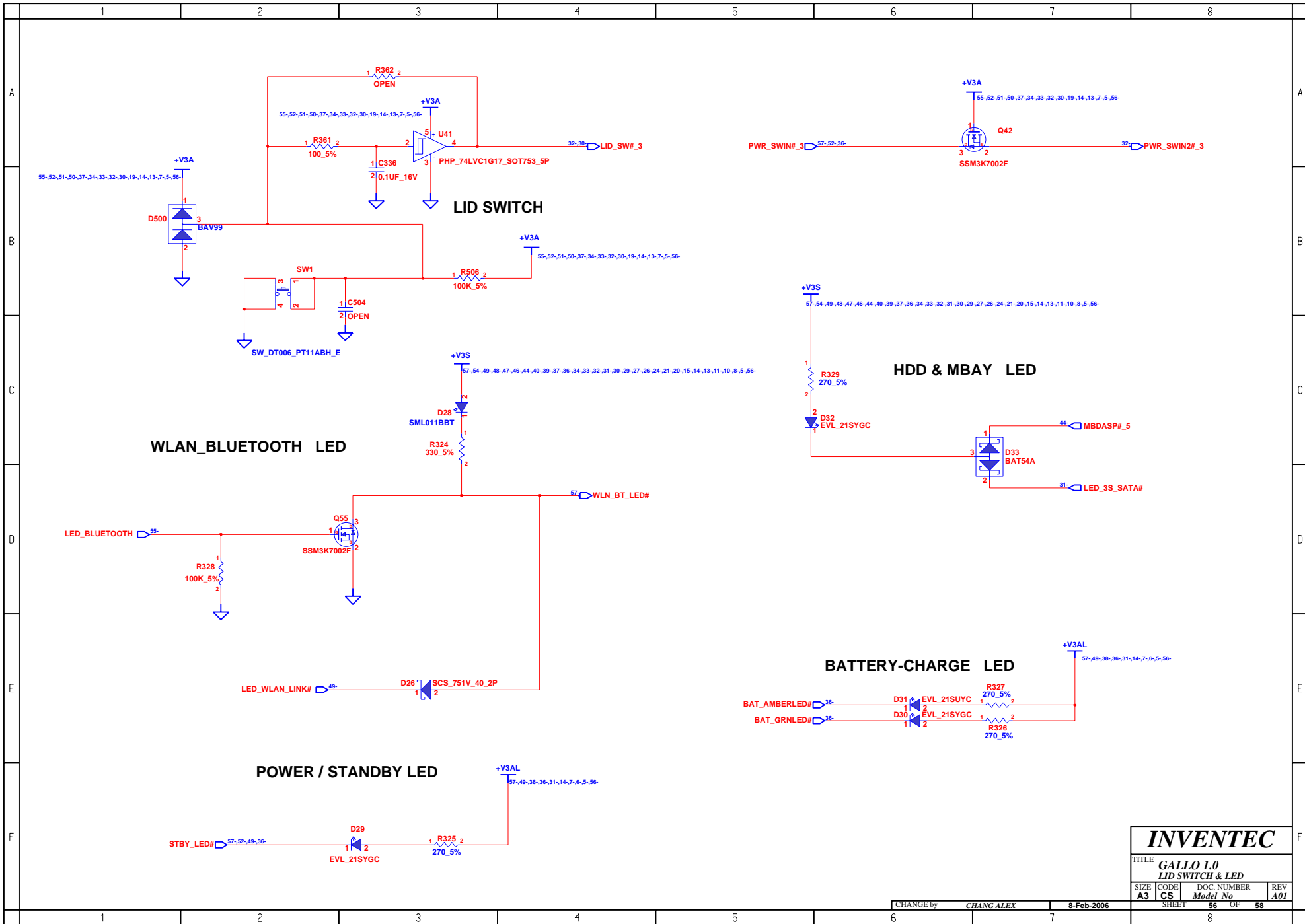

INVENTEC

TITLE			
GALLO 1.0			
LID SWITCH & LED			
SIZE	CODE	DOC. NUMBER	REV
A3	CS	Model No	A01

CHANGE by *CHANG ALEX* 8-Feb-2006

SHEET 56 OF 58

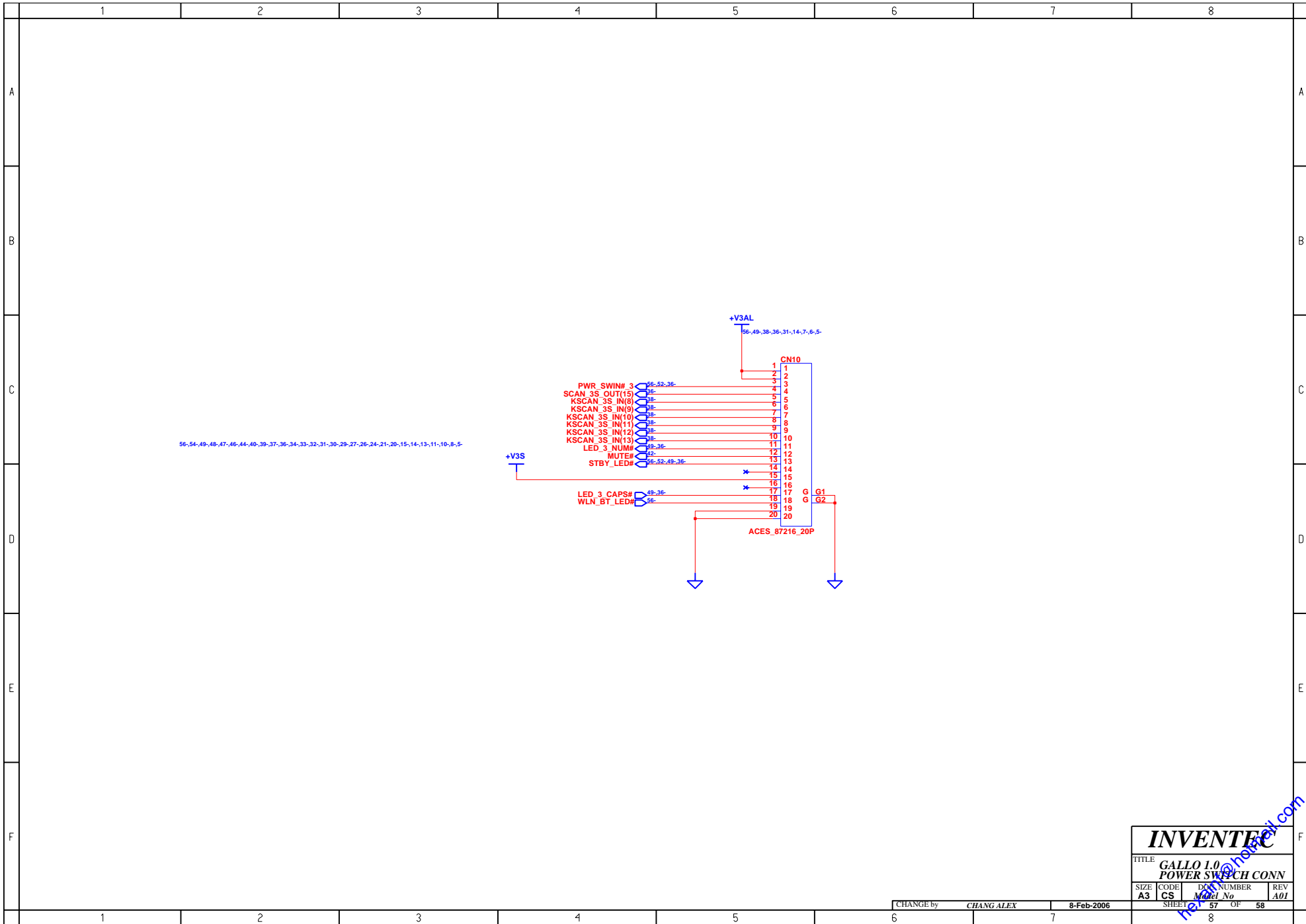

INVENTEC

TITLE **GALLO 1.0**
POWER SWITCH CONN

SIZE A3	CODE CS	DOC NUMBER <i>Model No</i>	REV A01
-------------------	-------------------	-------------------------------	-------------------

SHEET 57 OF 58

CHANGE by **CHANG ALEX** 8-Feb-2006

net@inventec.com

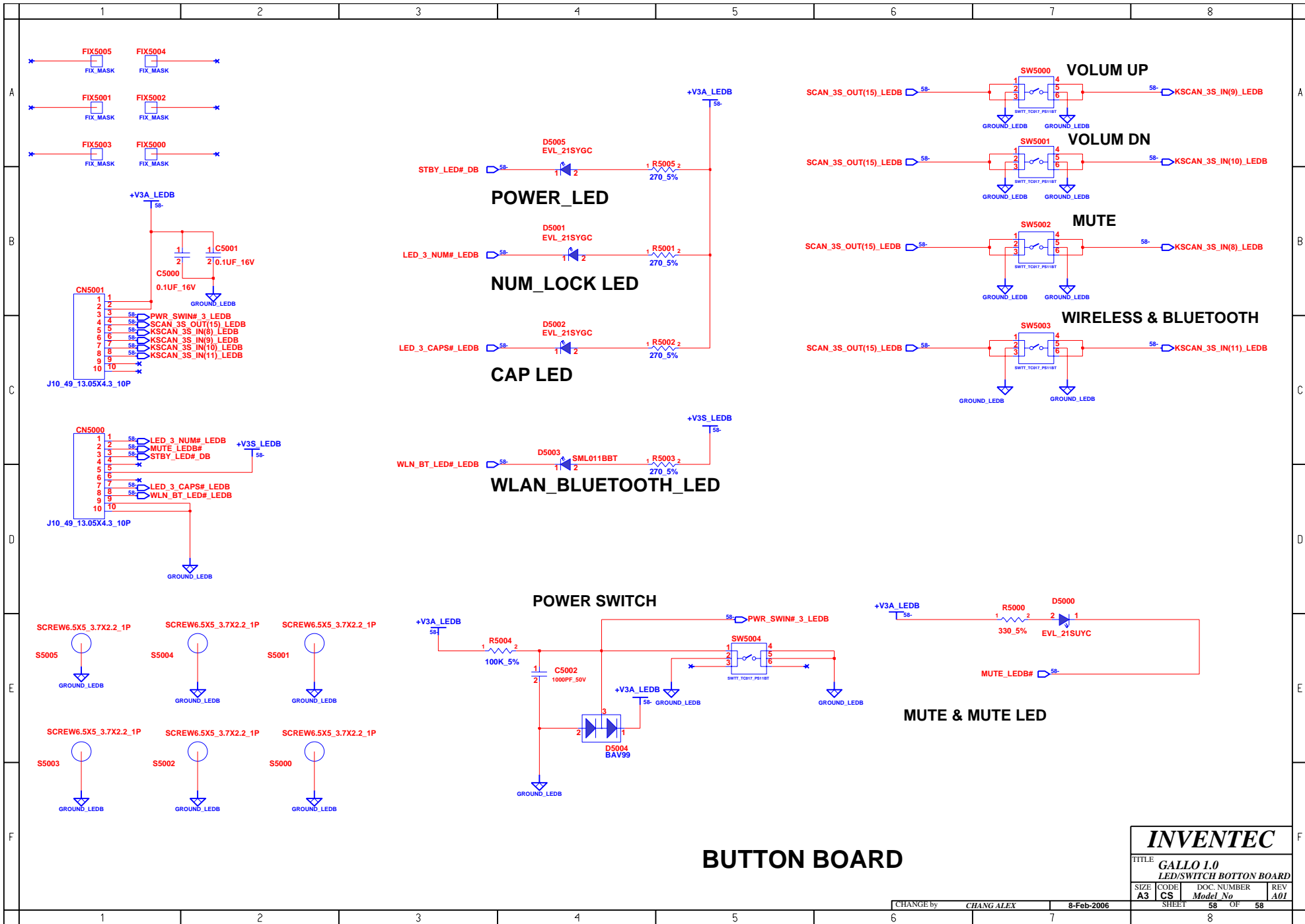

BUTTON BOARD

INVENTEC

TITLE			
GALLO 1.0			
LED/SWITCH BOTTON BOARD			
SIZE	CODE	DOC. NUMBER	REV
A3	CS	Model No	A01

CHANGE by *CHANG ALEX* 8-Feb-2006

SHEET 58 OF 58