

Thank you for purchasing this Factory Service Manual CD/DVD from servicemanuals4u.com.

Please check out our eBay auctions for more great deals on Factory Service Manuals:

servicemanuals4u



Maintenance and Service Guide

Compaq Evo N115 Series

Document Part Number: 263816-001

January 2002

This guide is a troubleshooting reference used for maintaining and servicing the notebook. It provides comprehensive information on identifying computer features, components, and spare parts, troubleshooting computer problems, and performing computer disassembly procedures.

© 2002 Compaq Information Technologies Group, L.P.

Compaq, the Compaq logo, and Evo are trademarks of Compaq Information Technologies Group, L.P. in the U.S. and/or other countries.

Microsoft and Windows are trademarks of Microsoft Corporation in the U.S. and/or other countries.

Athlon, Duron, and PowerNow! are trademarks of the AMD Corporation in the U.S. and/or other countries.

All other product names mentioned herein may be trademarks of their respective companies.

Compaq shall not be liable for technical or editorial errors or omissions contained herein. The information in this document is provided “as is” without warranty of any kind and is subject to change without notice. The warranties for Compaq products are set forth in the express limited warranty statements accompanying such products. Nothing herein should be construed as constituting an additional warranty.

Maintenance and Service Guide

First Edition January 2002

Document Part Number: 263816-001

Contents

1 Product Description

1.1 Models	1-2
1.2 Features	1-8
1.3 Clearing a Password.	1-9
1.4 Power Management	1-10
1.5 Computer External Components	1-11
1.6 Design Overview	1-22

2 Troubleshooting

2.1 Using the PhoenixBIOS Setup Utility	2-1
2.2 Troubleshooting Flowcharts.	2-2

3 Illustrated Parts Catalog

3.1 Serial Number Location	3-1
3.2 Computer System Major Components	3-2
3.3 Plastics and Hardware Kit Components.	3-8
3.4 Cable Kit Components	3-9
3.5 Mass Storage Devices	3-10
3.6 Miscellaneous.	3-12

4 Removal and Replacement Preliminaries

4.1 Tools Required	4-1
4.2 Service Considerations	4-2
Plastic Parts	4-2
Cables and Connectors	4-2
4.3 Preventing Damage to Removable Drives	4-3
4.4 Preventing Electrostatic Damage	4-4
4.5 Packaging and Transporting Precautions	4-4
4.6 Workstation Precautions	4-5
4.7 Grounding Equipment and Methods	4-6

5 Removal and Replacement Procedures

5.1 Serial Number	5-2
5.2 Disassembly Sequence Chart	5-3
5.3 Preparing the Computer for Disassembly	5-4
5.4 Computer Feet	5-11
5.5 Memory Expansion Board	5-11
5.6 Mini PCI Communications Board	5-13
5.7 Optical Drive	5-16
5.8 LED Cover	5-18
5.9 Keyboard	5-20
5.10 Display	5-22
5.11 Heat Spreader	5-28
5.12 Processor	5-34
5.13 Disk Cell RTC Battery	5-36
5.14 Top Cover	5-38
5.15 Diskette Drive	5-42
5.16 Charger Board	5-46
5.17 Left Side Panel	5-48
5.18 Right Side Panel	5-50
5.19 Speaker Assembly	5-52
5.20 Audio Board	5-54
5.21 Fan	5-56
5.22 System Board	5-58

6 Specifications

A Connector Pin Assignments

B Power Cord Set Requirements

3-Conductor Power Cord Set	B-1
General Requirements	B-1
Country-Specific Requirements	B-2
Notes	B-2

C Screw Listing

Index

Product Description

The Compaq Evo N115 Series of Personal Computers offers advanced modularity, AMD Mobile Athlon 4 and AMD Mobile Duron processors with 64-bit architecture, industry-leading Accelerated Graphics Port (AGP) implementation, and extensive multimedia support.



Figure 1-1. Compaq Evo N115

1.1 Models

Computer models are shown in Table 1-1.

**Table 1-1
Compaq Evo N115
Models and Model Naming Conventions**

Key										
N1	A	100	X4	20	V	M	25	L	O	XXXXXXXX-XXX
1	2	3	4	5	6	7	8	9	10	11
Key	Description				Options					
1	Brand/Series designator				N1 = Evo Notebook 115					
2	Processor type				A = AMD Athlon			D = AMD Duron		
3	Processor speed				110 = 1.10 GHz 100 = 1.00 GHz 950 = 950 MHz			900 = 900 MHz 850 = 850 MHz		
4	Display type/size/resolution				X = XGA (1024 × 768)			4 = 14.x-inch 3 = 13.x-inch		
5	Hard drive size				30 = 30 GB 20 = 20 GB			15 = 15 GB 10 = 10 GB		
6	Optical drive designator				D = CD-ROM V = DVD-ROM R = CD-RW			W = DVD-RW omitted = none		
7	Integrated communication				M = modem			0 = none		
8	RAM				25 = 256 MB			12 = 128 MB		
9	Battery cells/type				L = 8 cells, Lithium ion (Li ion)					
10	Operating system				O = Windows XP					
11	SKU#									

**Table 1-1
Compaq Evo N115
Models and Model Naming Conventions (Continued)**

Build-to-Order Models										
1	2	3	4	5	6	7	8	9	10	11
N1	A	100	X4	20	W	M	25	L	O	SKU#
Belgium				Config. code = KDH8						470023-558
Europe				Config. code = KDH8						470020-516
France				Config. code = KDH8						470020-518
Germany				Config. code = KDH8						470020-520
Italy				Config. code = KDH8						470020-522
The Netherlands				Config. code = KDH8						470023-559
Poland				Config. code = KDH8						470024-539
Switzerland				Config. code = KDH8						470024-818
United Kingdom				Config. code = KDH8						470023-560
United States				Config. code = KDKU						470023-833
United States				Config. code = KDKN						470023-551
N1	A	100	X4	20	V	M	25	L	O	SKU#
Australia/New Zealand				Config. code = KDKV						470020-462
Asia/Pacific				Config. code = KDKV						470021-815
India				Config. code = KDKV						470020-466
Portugal				Config. code = KDH2						470024-541
Spain				Config. code = KDH2						470024-542
Thailand				Config. code = KDKV						470024-535

**Table 1-1
Compaq Evo N115
Models and Model Naming Conventions (Continued)**

Build-to-Order Models (Continued)										
N1	D	950	X4	20	V	M	25	L	O	SKU#
Belgium				Config. code = KDH7						470024-815
Denmark				Config. code = KDH7						470024-536
Europe				Config. code = KDH7						470023-930
Germany				Config. code = KDH7						470025-650
Italy				Config. code = KDH7						470023-570
Latin America				Config. code = KDH3						470024-543
The Netherlands				Config. code = KDH7						470024-816
Poland				Config. code = KDH7						470024-538
Spain (NAFTA)				Config. code = KDH3						470024-544
Sweden				Config. code = KDH7						470024-817
Switzerland				Config. code = KDH7						470023-576
United States				Config. code = KDKM						470023-557
N1	D	950	X4	20	W	M	12	L	O	SKU#
France				Config. code = KJ21						470024-283
United Kingdom				Config. code = KJ21						470024-540
N1	D	950	X4	20	D	M	12	L	O	SKU#
Australia/New Zealand				Config. code = KDH1						470023-555
Asia/Pacific				Config. code = KDH1						470023-968
India				Config. code = KDH1						470023-556
Thailand				Config. code = KDH1						470024-534

Table 1-1
Compaq Evo N115
Models and Model Naming Conventions (Continued)

Build-to-Order Models (Continued)										
N1	D	900	X4	20	W	M	25	L	O	SKU#
Japan				Config. code = KDJR						470023-566
N1	D	900	X4	20	V	M	25	L	O	SKU#
Canada				Config. code = KDHC						470020-491
French Canada				Config. code = KDHC						470020-511
United States				Config. code = KDHB						470020-490
N1	D	900	X4	20	V	M	12	L	O	SKU#
France				Config. code = KDKW						470024-749
United Kingdom				Config. code = KDJR						470024-192
N1	D	900	X4	20	D	M	12	L	O	SKU#
Denmark				Config. code = KDJS						470020-473
Europe				Config. code = KDJS						470020-474
Finland				Config. code = KDJS						470020-475
Italy				Config. code = KDJS						470020-479
Latin America				Config. code = KDH9						470020-480
The Netherlands				Config. code = KDJS						470020-488
Norway				Config. code = KDJS						470020-481
Portugal				Config. code = KDJS						470020-483
Spain				Config. code = KDJS						470020-484
Spain (NAFTA)				Config. code = KDH9						470020-489
Sweden				Config. code = KDJS						470020-485

**Table 1-1
Compaq Evo N115
Models and Model Naming Conventions (Continued)**

Build-to-Order Models (Continued)

N1	D	900	X4	20	R	M	25	L	O	SKU#
Japan				Config. code = KDJP						470023-561
N1	D	900	X4	10	V	M	12	L	O	SKU#
United States				Config. code = KDH6						470024-820

Configure-to-Order Models

All configure-to-order models are United States models and have a config. code of **JNZZ**.

N1	A	100	X4	20	V	C	25	L	O	470025-434
N1	A	100	X4	20	V	C	25	L	O	470024-822
N1	A	100	X4	20	V	C	12	L	O	470025-432
N1	A	100	X4	20	W	C	25	L	O	470025-429
N1	A	100	X4	20	W	C	12	L	O	470025-427
N1	A	100	X3	20	V	C	25	L	O	470025-433
N1	A	100	X3	20	V	C	12	L	O	470025-430
N1	A	100	X3	20	W	C	25	L	O	470025-428
N1	A	100	X3	20	W	C	12	L	O	470025-426
N1	D	950	X4	20	V	C	25	L	O	470025-444
N1	D	950	X4	20	V	C	12	L	O	470025-441
N1	D	950	X4	20	D	C	25	L	O	470025-438
N1	D	950	X4	20	D	C	12	L	O	470025-436

Table 1-1
Compaq Evo N115
Models and Model Naming Conventions (Continued)

Configure-to-Order Models

All configure-to-order models are United States models and have a config. code of **JNZZ**.

N1	D	950	X4	10	V	C	25	L	O	470025-425
N1	D	950	X4	10	V	C	12	L	O	470025-423
N1	D	950	X4	10	D	C	25	L	O	470025-420
N1	D	950	X4	10	D	C	12	L	O	470025-418
N1	D	950	X3	20	V	C	25	L	O	470025-442
N1	D	950	X3	20	V	C	12	L	O	470025-439
N1	D	950	X3	20	D	C	25	L	O	470025-437
N1	D	950	X3	20	D	C	12	L	O	470025-435
N1	D	950	X3	10	V	C	25	L	O	470025-424
N1	D	950	X3	10	V	C	12	L	O	470025-422
N1	D	950	X3	10	D	C	25	L	O	470025-419
N1	D	950	X3	10	D	C	12	L	O	470025-414
N1	D	950	X3	10	D	C	12	L	O	470025-415
N1	D	900	X4	15	D	C	25	L	O	470024-821

1.2 Features

- 1.1- or 1.0-GHz, or 950- or 900-MHz AMD Mobile Athlon 4 processor, with 256-KB integrated L2 cache, or 950-, 900-, or 850-MHz AMD Mobile Duron processor, with 64-KB integrated L2 cache, varying by computer model
- VIA ProSavage KN 133 graphics accelerator with up to 32-MB of shared SDRAM and 4X AGP graphics card
- 128-MB high-performance Synchronous DRAM (SDRAM), expandable to 384 MB
- Microsoft Windows XP Home or Professional, varying by computer model
- 14.1- or 13.3-inch XGA, TFT (1024 × 768) display with over 16.7 million colors, varying by computer model
- Full-size keyboard with TouchPad pointing device
- Network interface card (NIC) integrated on the system board, with a mini PCI V.92 modem
- Support for one Type I/II/III PC Card slot with support for both 32-bit CardBus and 16-bit PC Cards
- External 60W AC adapter with power cord
- 8-cell Lithium ion (Li ion) battery pack
- 30-, 20-, 15-, or 10-GB high-capacity hard drive, varying by computer model

- Connectors for:
 - ❑ RJ-45 network
 - ❑ RJ-11 modem
 - ❑ Universal Serial Bus
 - ❑ S-Video
 - ❑ Parallel devices
 - ❑ External monitor
 - ❑ AC power
 - ❑ Stereo line out/headphone
 - ❑ Mono microphone
 - ❑ External keyboard/mouse
- JBL Pro stereo speakers with bass reflex

1.3 Clearing a Password

If the notebook you are servicing has an unknown password, follow these steps to clear the password. These steps also clear CMOS:

1. Prepare the computer for disassembly (refer to Section 5.3, “Preparing the Computer for Disassembly,” for more information).
2. Remove the RTC battery (refer to Section 5.13, “Disk Cell RTC Battery”).
3. Wait approximately five minutes.
4. Replace the RTC battery and reassemble the computer.
5. Connect AC power to the computer. Do **not** reinsert any battery packs at this time.
6. Turn on the computer.

All passwords and all CMOS settings have been cleared.

1.4 Power Management

The computer comes with power management features that extend battery operating time and conserve power. The computer supports the following power management features:

- Standby
- Hibernation
- Setting customization by the user
- Hotkeys for setting level of performance
- Smart battery that provides an accurate battery power gauge
- Battery calibration
- Lid switch suspend/resume
- Power/suspend button
- Advanced Configuration and Power Management (ACP) compliance

1.5 Computer External Components

The external components on the right side of the computer are shown in Figure 1-2 and described in Table 1-2.

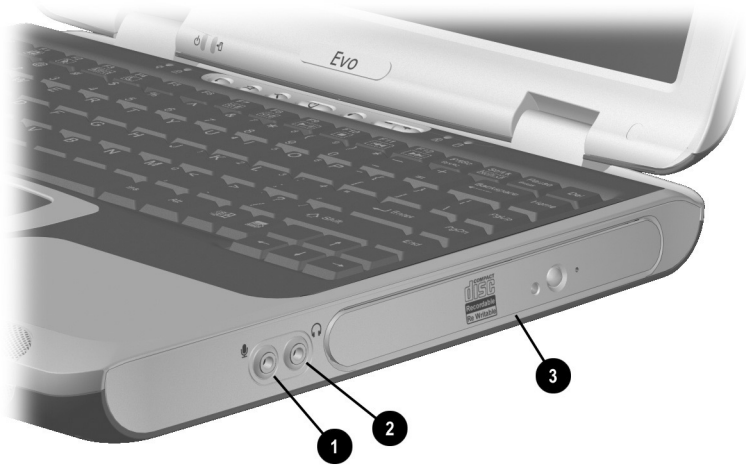

Figure 1-2. Right Side Components

**Table 1-2
Right Side Components**

Item	Component	Function
1	Mono microphone jack	Connects a mono microphone, disabling the built-in microphone.
2	Stereo speaker/ headphone jack	Connects stereo speakers, headphones, headset, or television audio.
3	Optical drive	Accepts a CD-ROM, CD-RW, DVD-ROM, or combination DVD-ROM/CD-RW drive.

The computer left side components are shown in Figure 1-3 and described in Table 1-3.

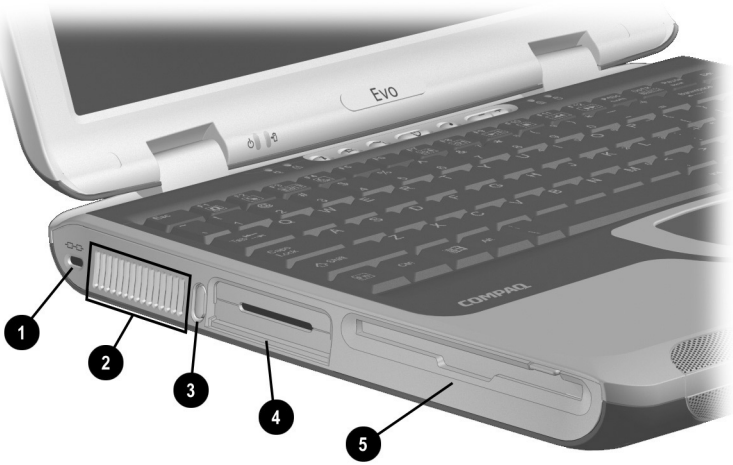



Figure 1-3. Left Side Components

Table 1-3
Left Side Components

Item	Component	Function
1	Security cable slot	Attaches an optional security cable to the computer.
2	Vents	Allow airflow to cool internal components.  CAUTION: To prevent damage, the computer shuts down if an overheating condition occurs. Do not block the cooling vent. Avoid placing the computer on a blanket, rug, or other flexible surface that may cover the vent area.
3	PC Card eject button	Ejects a PC Card from the PC Card slot.
4	PC Card slot	Supports a 32-bit (CardBus) or 16-bit PC Card.
5	Diskette drive	Accepts 3.5-inch diskettes.

The computer rear panel components are shown in Figure 1-4 and described in Table 1-4.

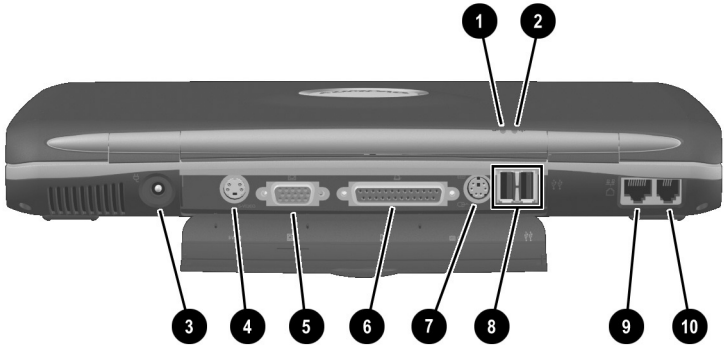

Figure 1-4. Rear Panel Components

**Table 1-4
Rear Panel Components**

Item	Component	Function
1	Battery light	On: A battery pack is charging. Blinking: A battery pack that is the only available power source has reached a low-battery condition.
2	Drive activity light	Turns on when the hard drive, CD-, or DVD-ROM drive is accessed.

Table 1-4
Rear Panel Components (Continued)

Item	Component	Function
3	DC power jack	Connects any one of the following: <ul style="list-style-type: none"> ■ AC adapter ■ Optional automobile power adapter/charger ■ Optional aircraft power adapter
4	S-Video connector	Connects a television, VCR, camcorder, or overhead projector.
5	External monitor connector	Connects an external monitor or overhead projector.
6	Parallel connector	Connects a parallel device.
7	External keyboard/mouse connector	Connects an optional full-sized keyboard or a mouse. Both external mouse and computer pointing device are active. An optional splitter/adaptor allows both an external keyboard and mouse to be used at the same time.
8	USB connectors (2)	Connects USB devices.
9	RJ-45 network jack	Connects the network cable. A network cable is not included with the computer.
10	RJ-11 modem jack	Connects the modem cable to an internal modem. A modem cable is included with internal modem models.

The keyboard components are shown in Figure 1-5 and described in Table 1-5.

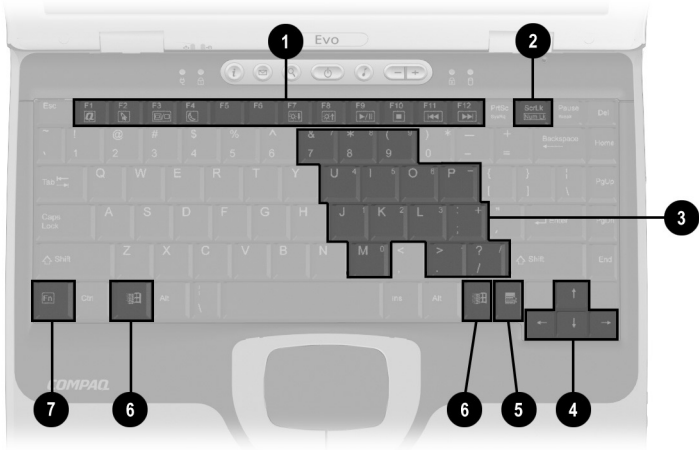

Figure 1-5. Keyboard Components

Table 1-5
Keyboard Components

Item	Component	Function
1	F1 through F12 function keys	Perform preset functions.
2	Num lock key	Turns on the numeric lock function.
3	Embedded numeric keypad	Converts keys to numeric keypad.
4	Cursor control keys	Move the cursor around the screen.
5	Windows application key	Displays a menu when using a Microsoft application. The menu is the same one that is displayed by pressing the right mouse button.
6	Windows logo keys	Displays the Windows Start menu.
7	Fn key	Used with hotkeys to perform preset hotkey functions.

The components on the top of the computer are shown in Figure 1-6 and described in Table 1-6.

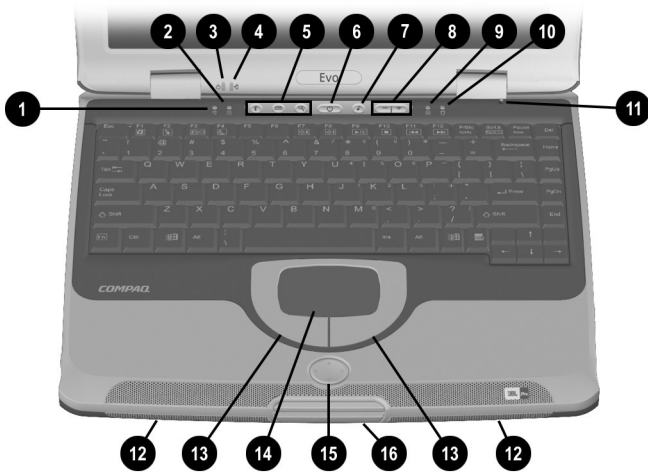

Figure 1-6. Top Components

**Table 1-6
Top Components**

Item	Component	Function
1	Power light	On: Power is turned on. Blinking: Computer is in Standby. The power light also blinks if a battery pack that is the only available power source reaches a low-battery condition.
2	Num lock light	On: Num lock is on and the embedded numeric keypad is enabled.
3	Drive activity light	Turns on when the hard drive, CD-, or DVD-ROM drive is accessed.

Table 1-6
Top Components (*Continued*)

Item	Component	Function
4	Battery light	On: A battery pack is charging. Blinking: A battery pack that is the only available power source has reached a low-battery condition.
5	Easy Access buttons (3)	Provide quick access to the Internet. Refer to the <i>Hardware Guide</i> that ships with the computer for information about these buttons.
6	Power button	Turns on the computer. Use the operating system Shut Down command to turn off the computer.
7	Digital audio button	Launches Windows Media Player to play MP3 music.
8	Volume control buttons	Adjust the volume of the stereo speakers.
9	Caps lock light	On: Caps lock is on.
10	Drive activity light	Turns on when the hard drive, CD-, or DVD-ROM drive is accessed.
11	Display lid switch	Turns off the computer display if the computer is closed while on.
12	Stereo speakers	Produce stereo sound.
13	TouchPad buttons	Function like the left and right mouse buttons on an external mouse.
14	TouchPad	Moves the mouse cursor, selects, and activates.
15	EasyScroll button	Scrolls the screen left, right, up, and down.
16	Display release latch	Opens the computer.

The external components on the bottom of the computer are shown in Figure 1-7 and described in Table 1-7.

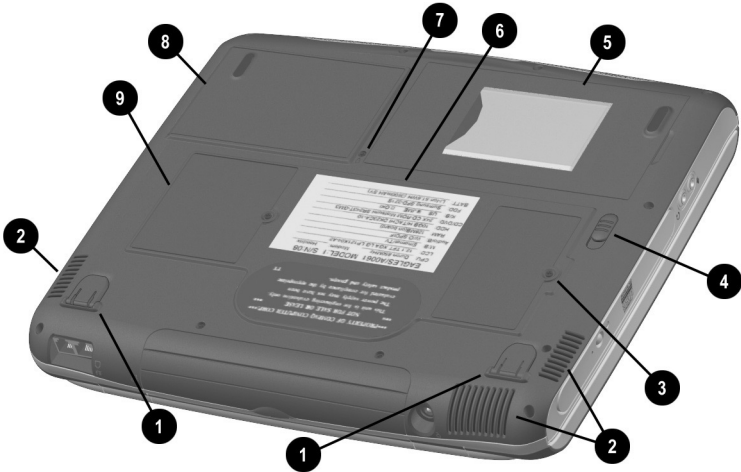

Figure 1-7. Bottom Components

**Table 1-7
Bottom Components**

Item	Component	Function
1	Tilt feet	Tilt the computer for ease of use.
2	Vents	Allow airflow to cool internal components.
<p>CAUTION: To prevent damage, the computer shuts down if an overheating condition occurs. Do not block the cooling vent. Avoid placing the computer on a blanket, rug, or other flexible surface that may cover the vent area.</p>		
3	Memory expansion compartment	Covers the memory expansion compartment that contains two memory expansion slots for memory expansion boards.

Table 1-7
Bottom Components (*Continued*)

Item	Component	Function
4	Battery pack release switch	Releases the battery pack from the battery compartment.
5	Battery bay	Accepts an 8-cell Lithium ion (Li ion) battery pack.
6	Label area	Contains the serial number and Microsoft Certificate of Authenticity labels, which may be needed when you call Compaq customer support or use some Windows operating systems.
7	Hard drive retention screw	Secures the hard drive to the computer.
8	Hard drive bay	Supports the removable primary hard drive. The hard drive is secured to the computer by one screw.
9	Mini PCI compartment	Contains the mini PCI modem card.

1.6 Design Overview

This section presents a design overview of key parts and features of the computer. Refer to Chapter 3, “Illustrated Parts Catalog,” to identify replacement parts, and Chapter 5, “Removal and Replacement Procedures,” for disassembly steps. The system board provides the following device connections:

- Memory expansion board
- Hard drive
- Display
- Keyboard/TouchPad or pointing stick
- Audio
- AMD Athlon and Duron processors
- Fan
- PC Card
- Modem or modem/NIC

The computer uses an electrical fan for ventilation. The fan is controlled by a temperature sensor and is designed to turn on automatically when high temperature conditions exist. These conditions are affected by high external temperatures, system power consumption, power management/battery conservation configurations, battery fast charging, and software applications. Exhaust air is displaced through the ventilation grill located on the left side of the computer.



CAUTION: To properly ventilate the computer, allow at least a 3-inch (7.6 cm) clearance on the left and right sides of the computer.

Troubleshooting



WARNING: Only authorized technicians trained by Compaq should repair this equipment. All troubleshooting and repair procedures are detailed to allow only subassembly/module level repair. Because of the complexity of the individual boards and subassemblies, no one should attempt to make repairs at the component level or to make modifications to any printed wiring board. Improper repairs can create a safety hazard. Any indication of component replacement or printed wiring board modification may void any warranty or exchange allowances.

Utilities that are preinstalled on the computer include:

- **PhoenixBIOS Setup Utility**—Allows you to modify or restore factory default settings and configure the system BIOS to diagnose and solve minor problems.
- **Power Management**—Allows you to reduce your computer power consumption.
- **Security**—Allows you to set or remove your power-on password.

2.1 Using the PhoenixBIOS Setup Utility

The PhoenixBIOS Setup Utility (PSU) is built into the system. You can configure the system BIOS and modify or restore factory default settings, such as date and time, types of disk drives, power management, and password settings. To run PSU, press the **F10** key during system startup. When the main screen displays, use the keyboard and arrow keys to move around the menus and make selections.

2.2 Troubleshooting Flowcharts

Table 2-1
Troubleshooting Flowcharts Overview

Flowchart	Description
2.1	Initial troubleshooting
2.2	No power, part 1
2.3	No power, part 2
2.4	No power, part 3
2.5	No power, part 4
2.6	No video, part 1
2.7	No video, part 2
2.8	Nonfunctioning docking station
2.9	No operating system (OS) loading
2.10	No OS loading from hard drive, part 1
2.11	No OS loading from hard drive, part 2
2.12	No OS loading from hard drive, part 3
2.13	No OS loading from diskette drive
2.14	No OS loading from CD- or DVD-ROM drive
2.15	No audio, part 1
2.16	No audio, part 2
2.17	Nonfunctioning device
2.18	Nonfunctioning keyboard
2.19	Nonfunctioning pointing device
2.20	No network or modem connection

Flowchart 2.1 - Initial Troubleshooting

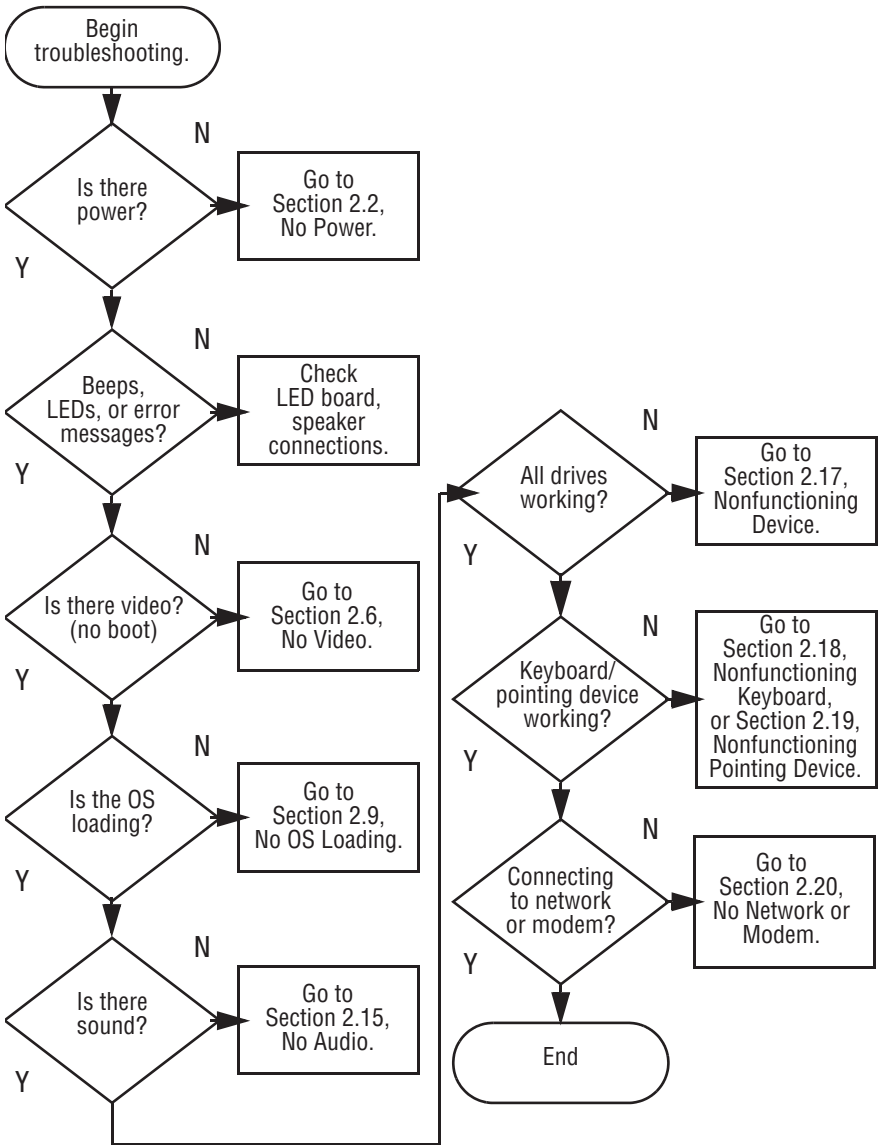

Flowchart 2.2 - No Power, Part 1

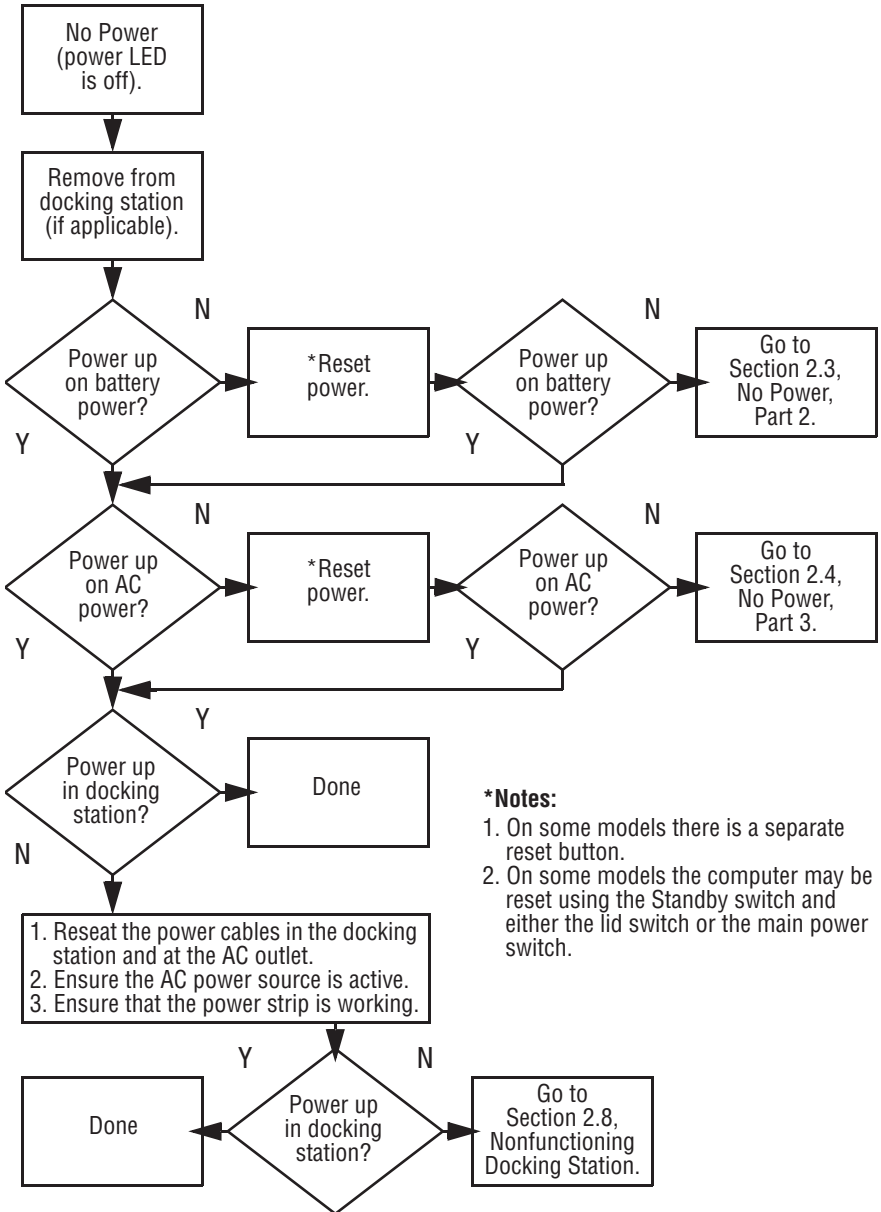

Flowchart 2.3 - No Power, Part 2

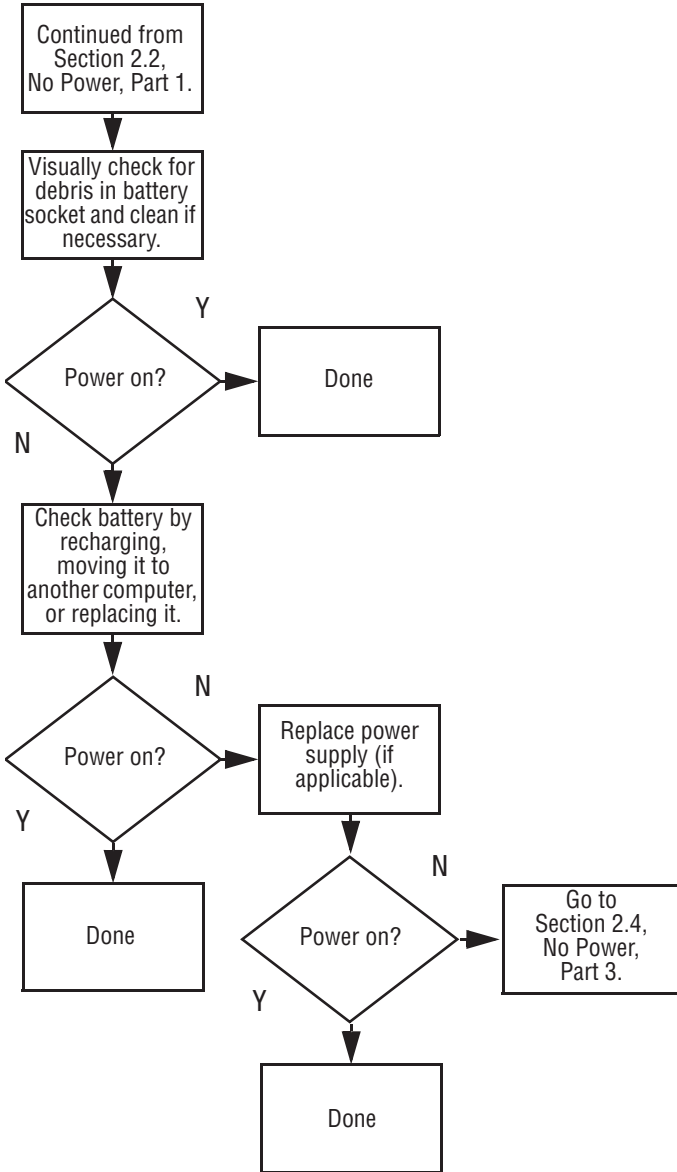

Flowchart 2.4 - No Power, Part 3

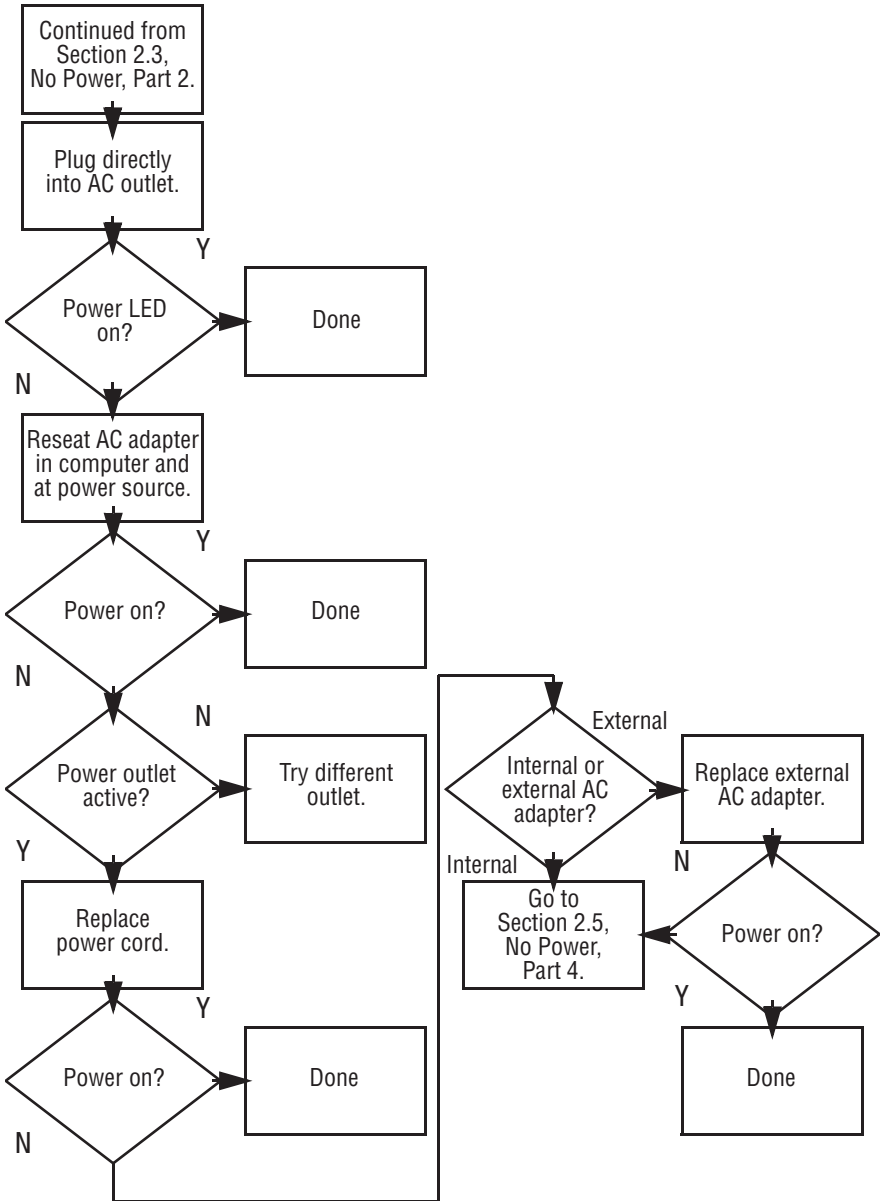

Flowchart 2.5 - No Power, Part 4

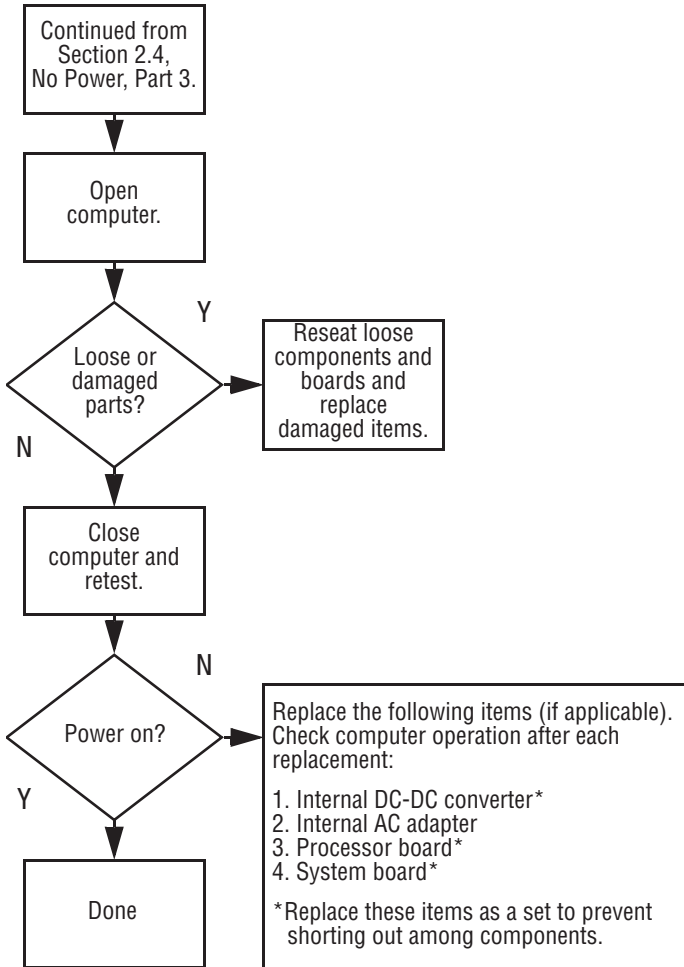

Flowchart 2.6 - No Video, Part 1

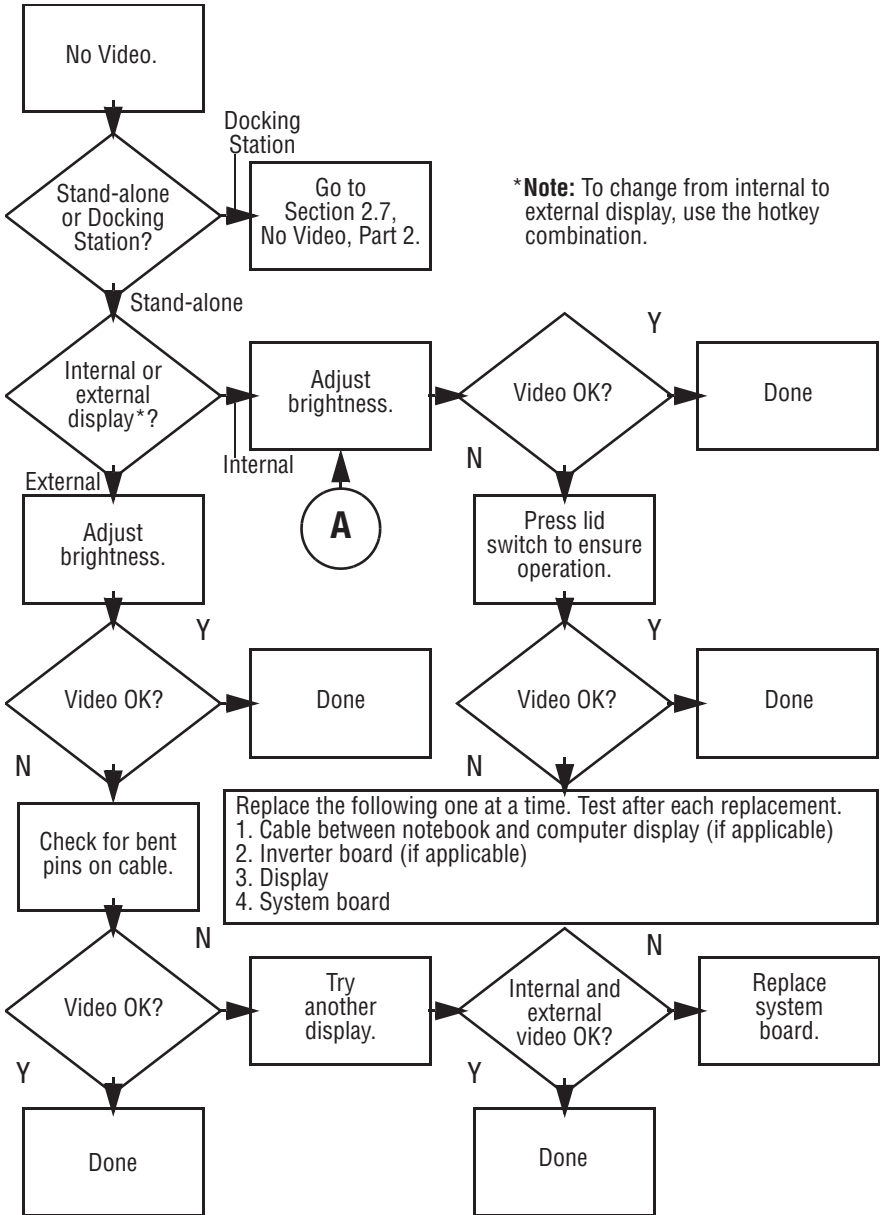

Flowchart 2.7 - No Video, Part 2

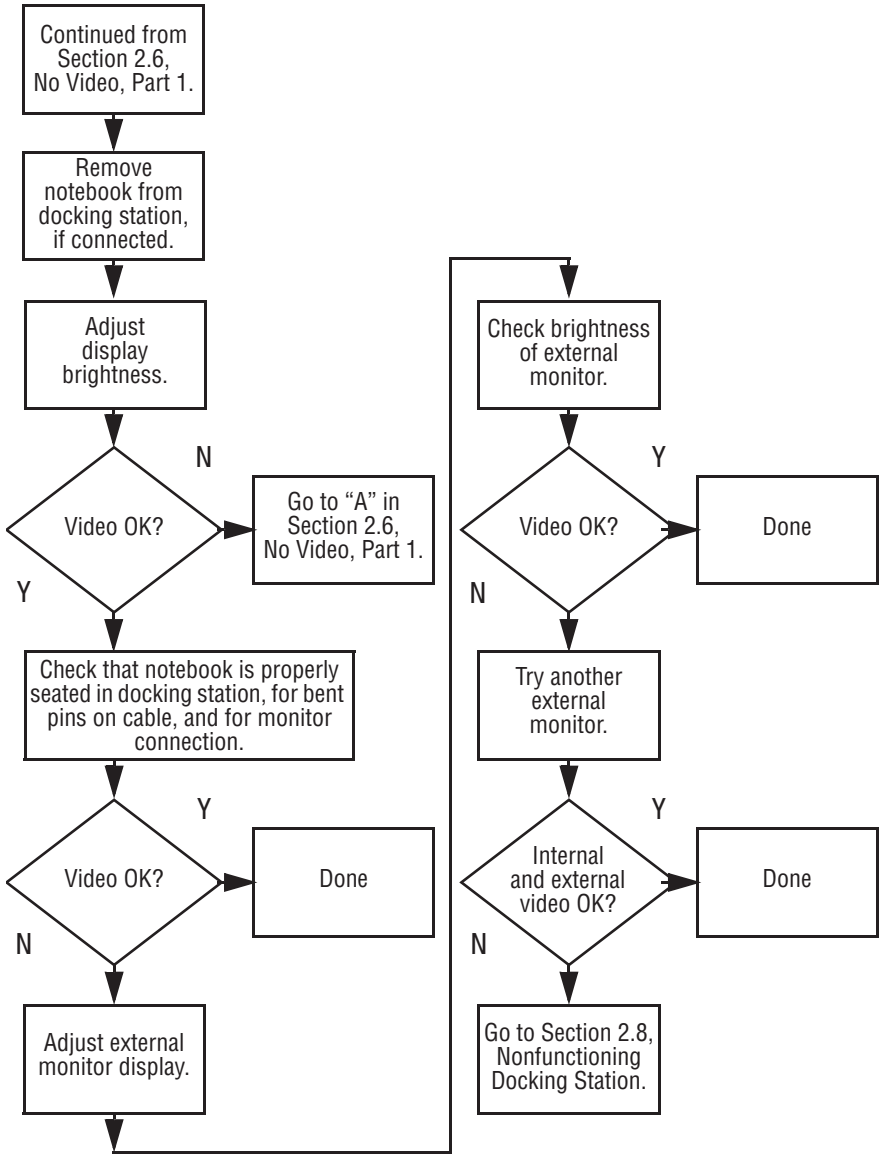

Flowchart 2.8 - Nonfunctioning Docking Station (if applicable)

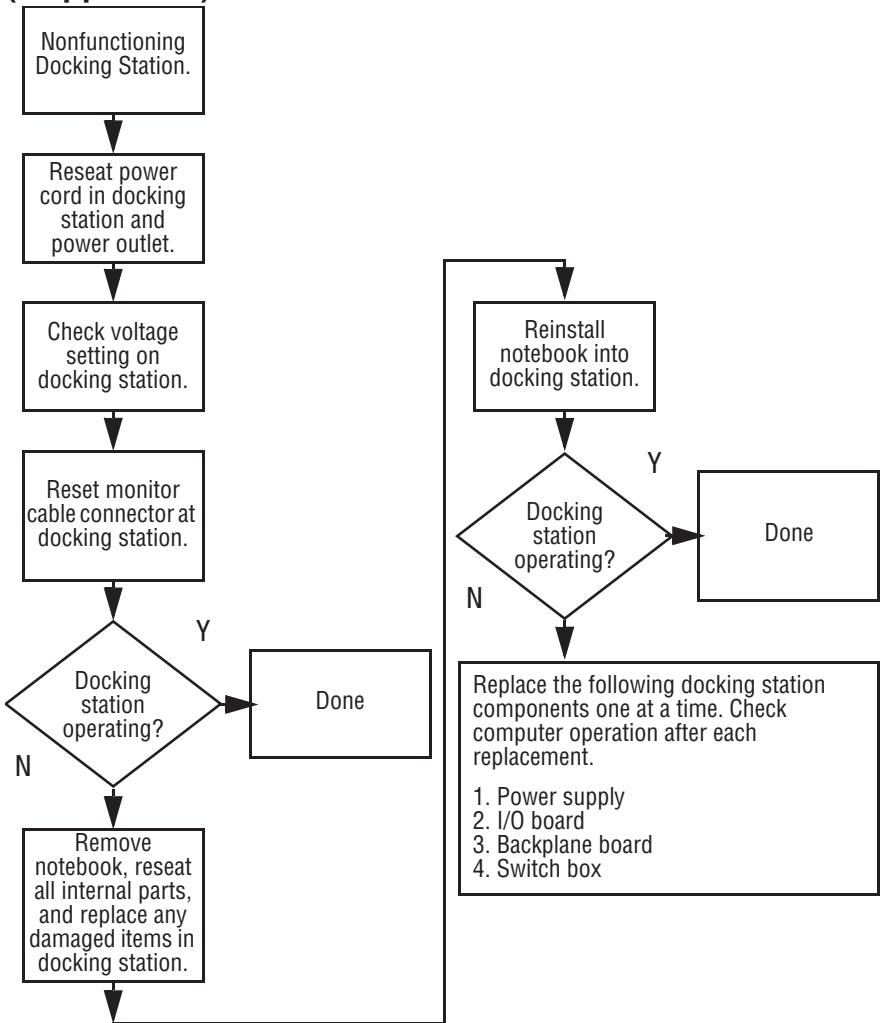

Flowchart 2.9 - No Operating System (OS) Loading

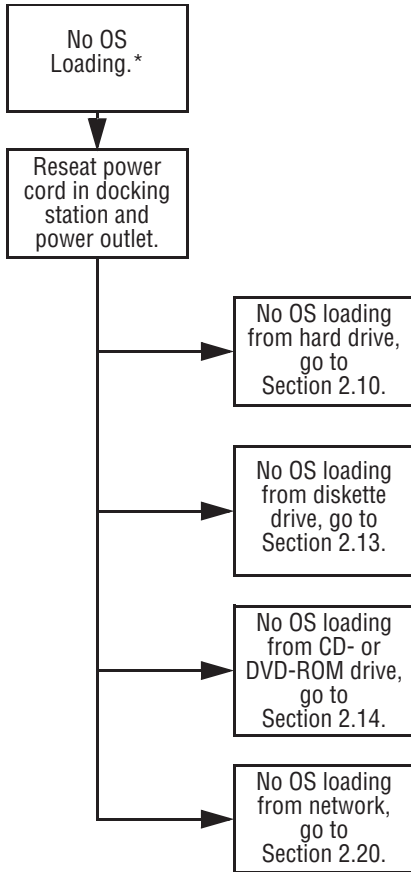

*Before beginning troubleshooting, always check cable connections, cable ends, and drives for bent or damaged pins.

Flowchart 2.10 - No OS Loading from Hard Drive, Part 1

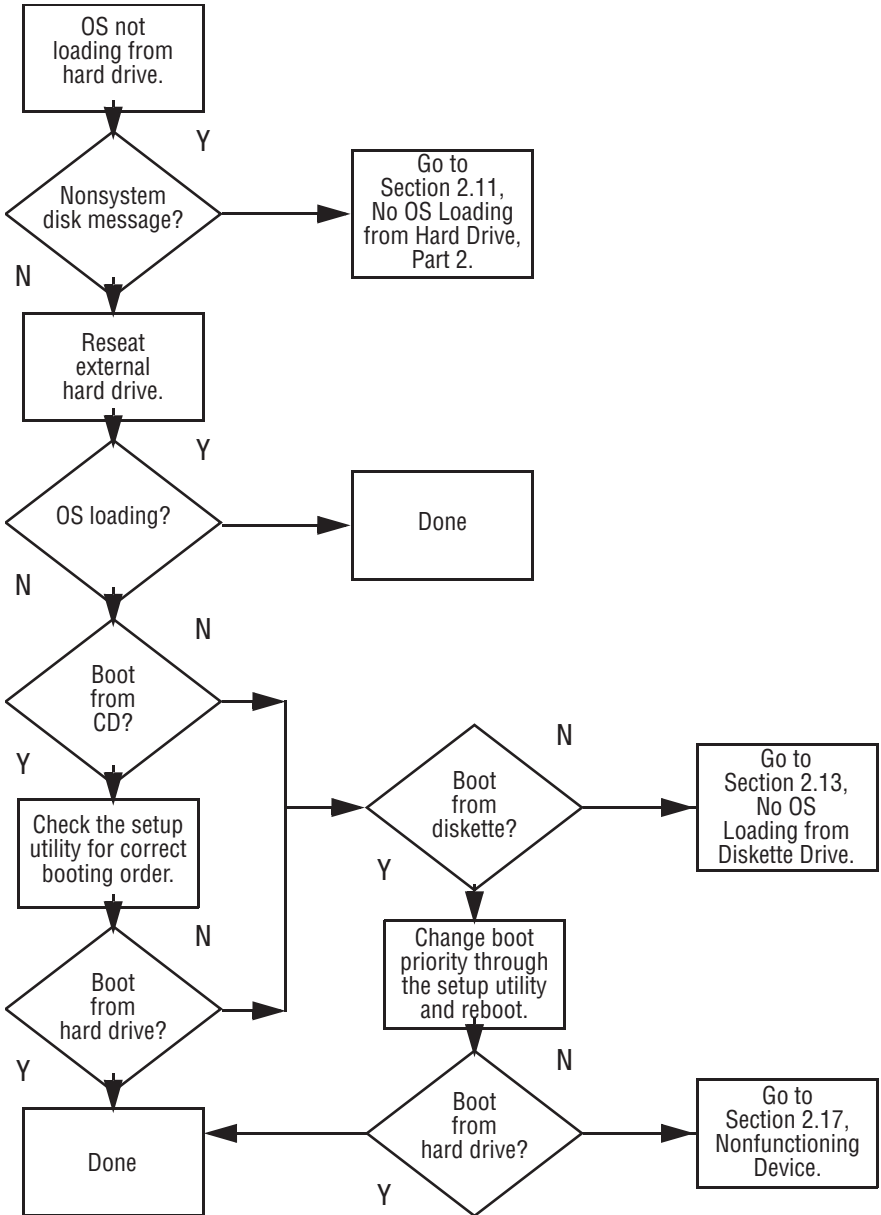

Flowchart 2.11 - No OS Loading from Hard Drive, Part 2

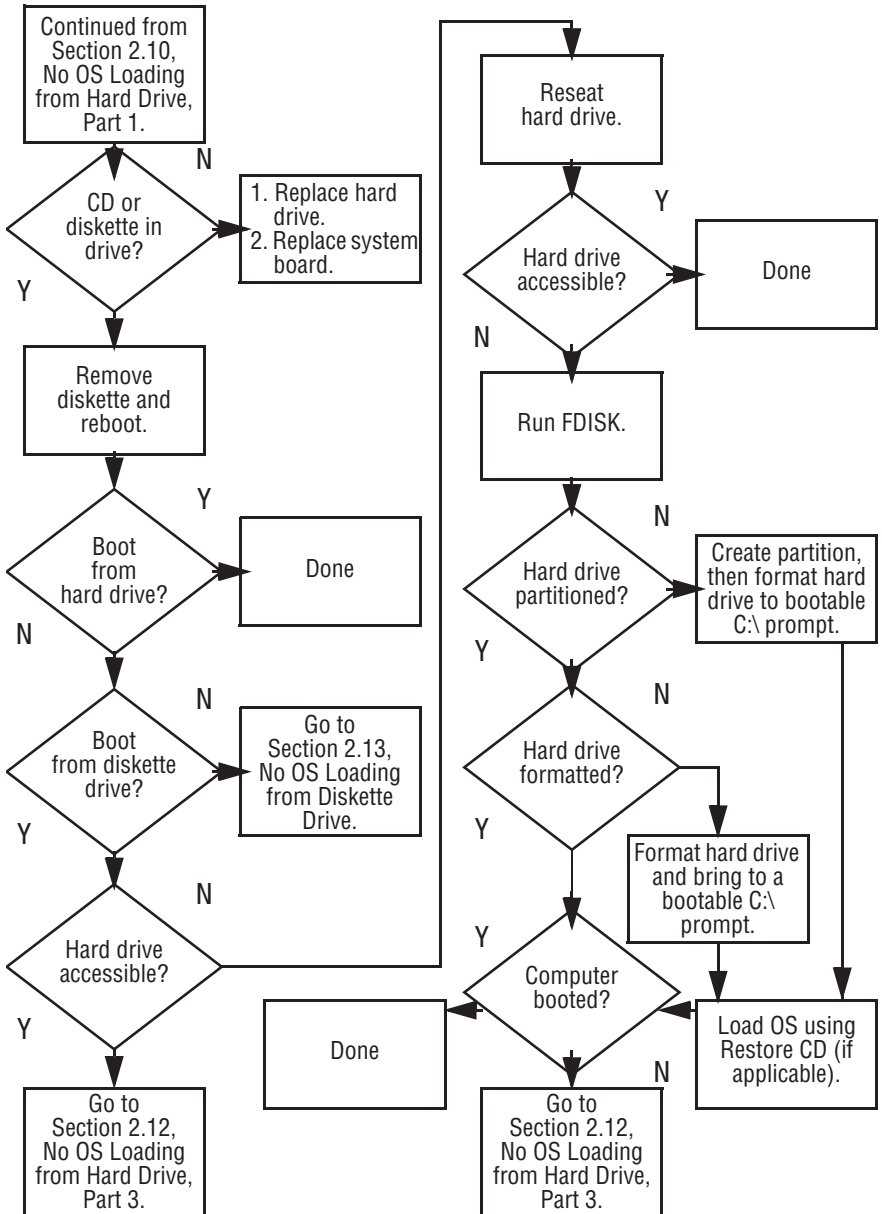

Flowchart 2.12 - No OS Loading from Hard Drive, Part 3

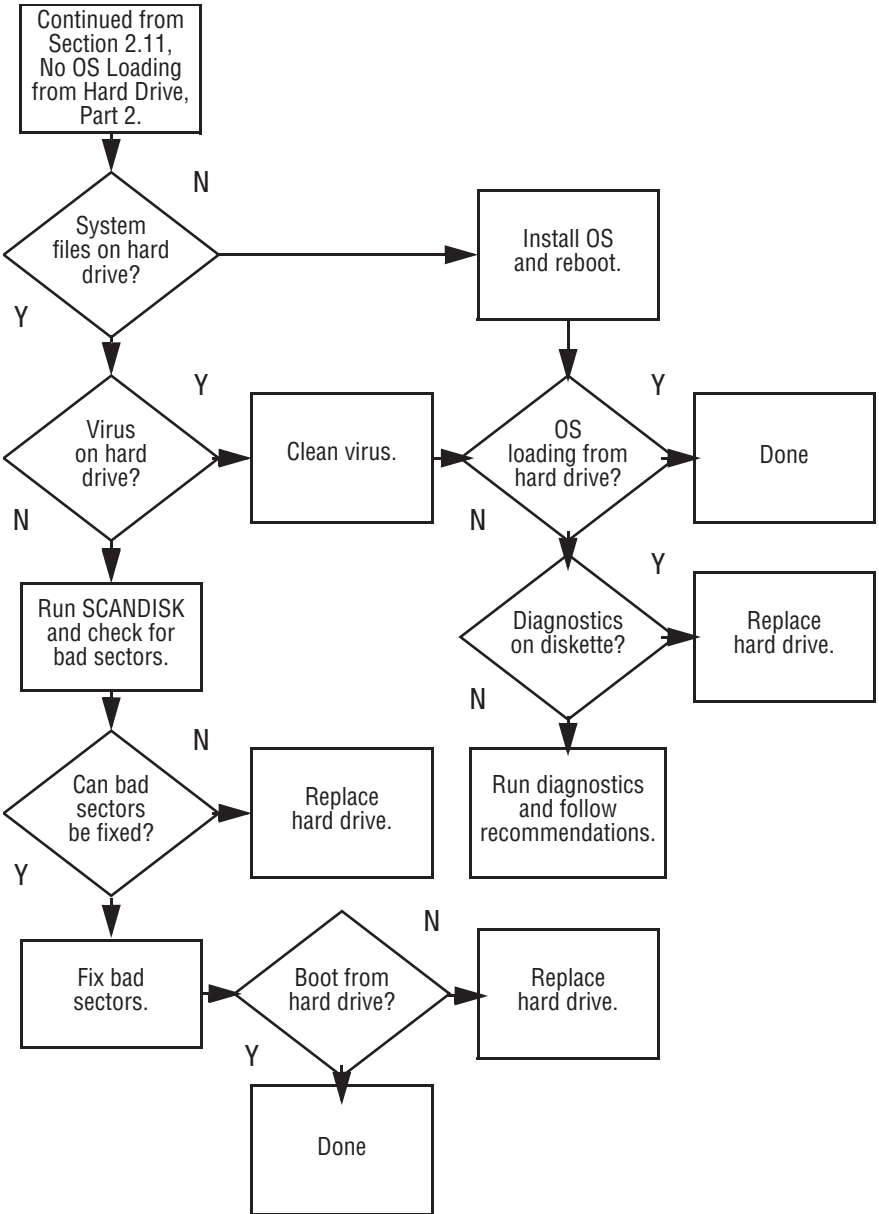

Flowchart 2.13 - No OS Loading from Diskette Drive

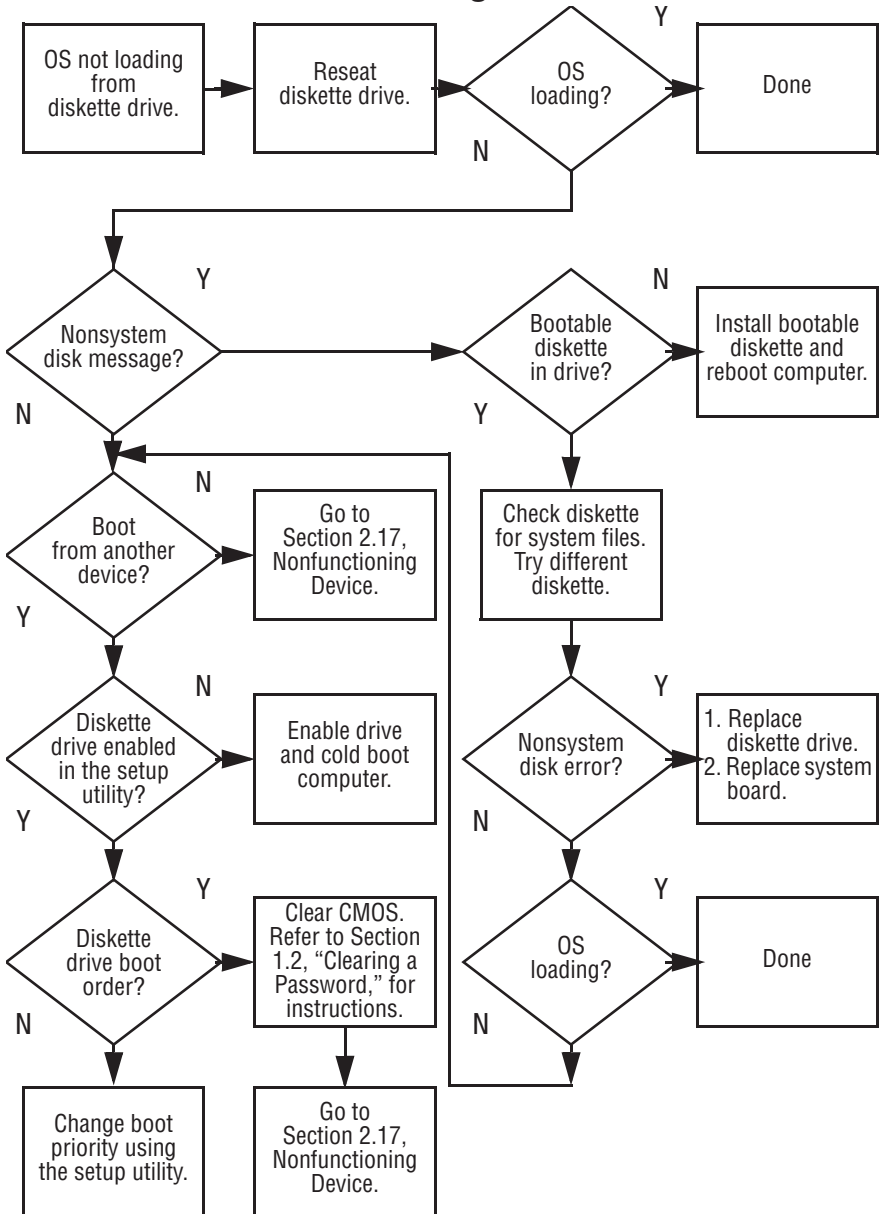

Flowchart 2.14 - No OS Loading from CD- or DVD-ROM Drive

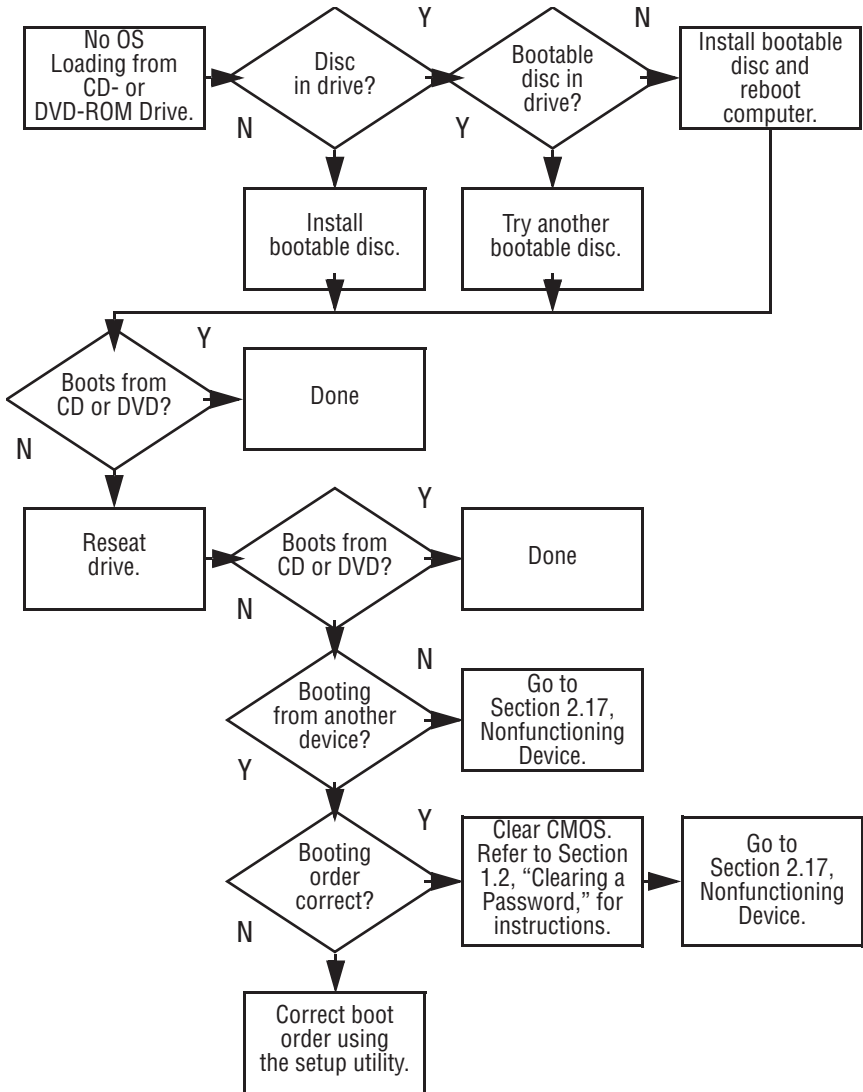

Flowchart 2.15 - No Audio, Part 1

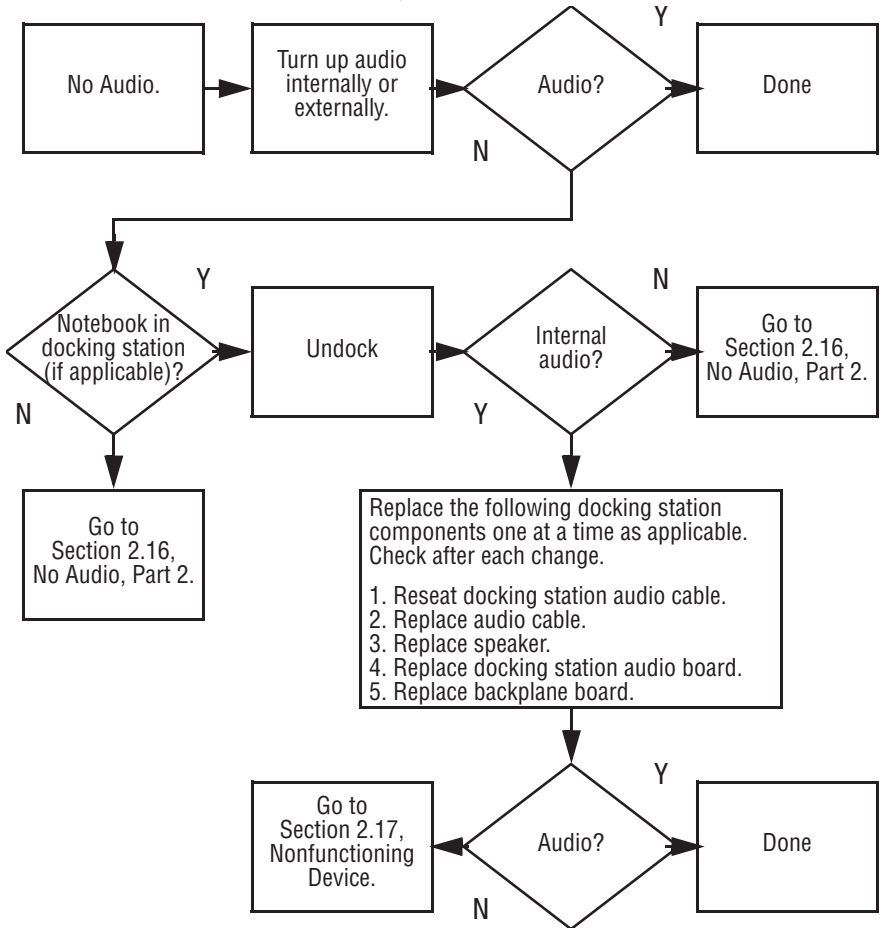

Flowchart 2.16 - No Audio, Part 2

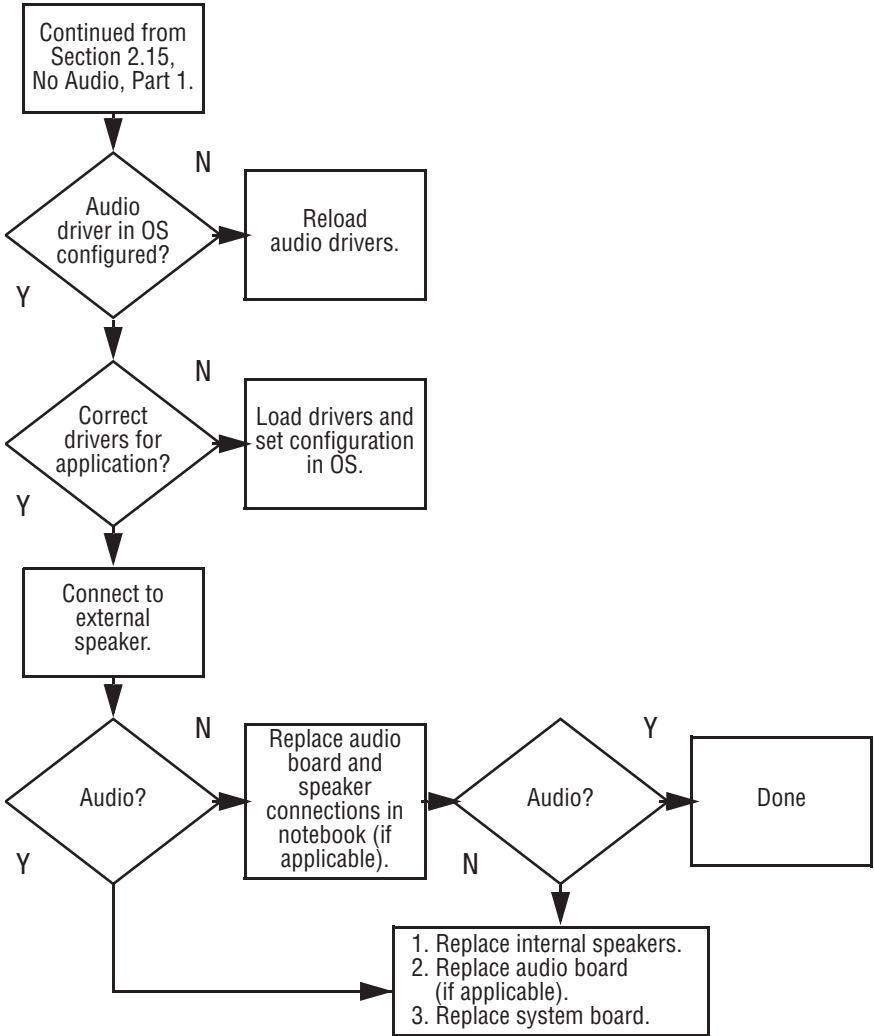

Flowchart 2.17 - Nonfunctioning Device

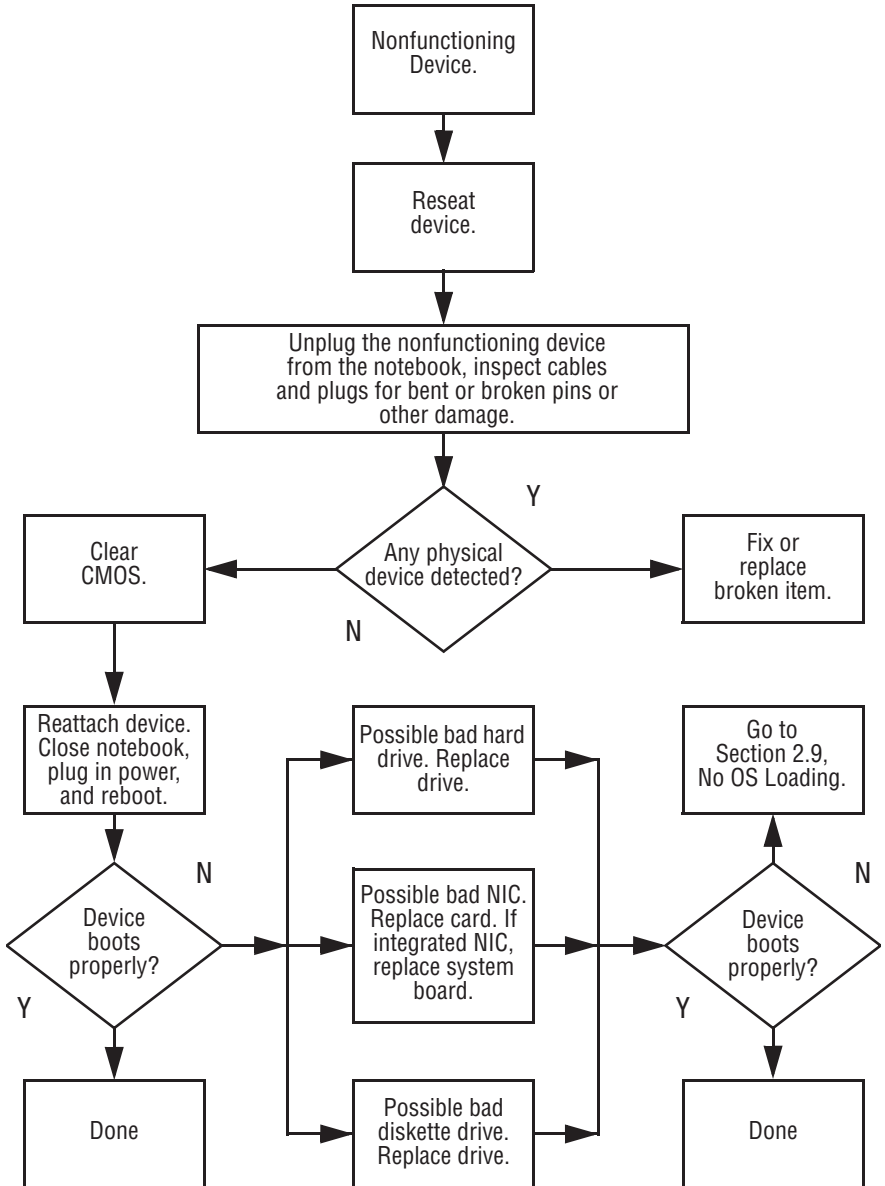

Flowchart 2.18 - Nonfunctioning Keyboard

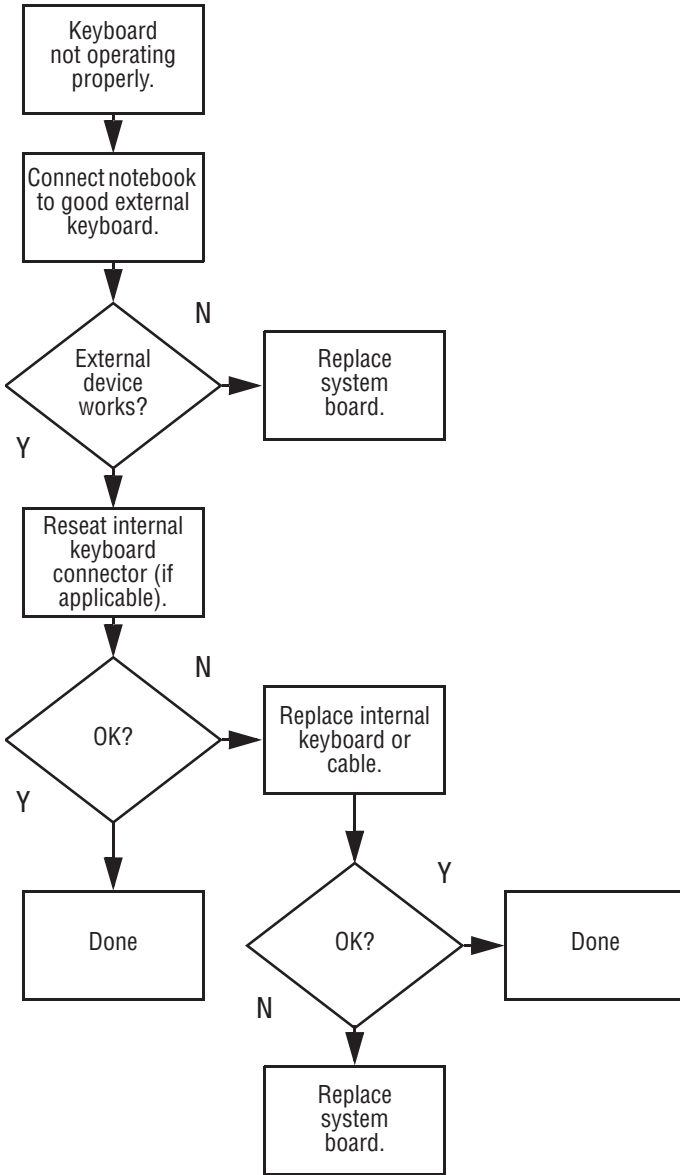

Flowchart 2.19 - Nonfunctioning Pointing Device

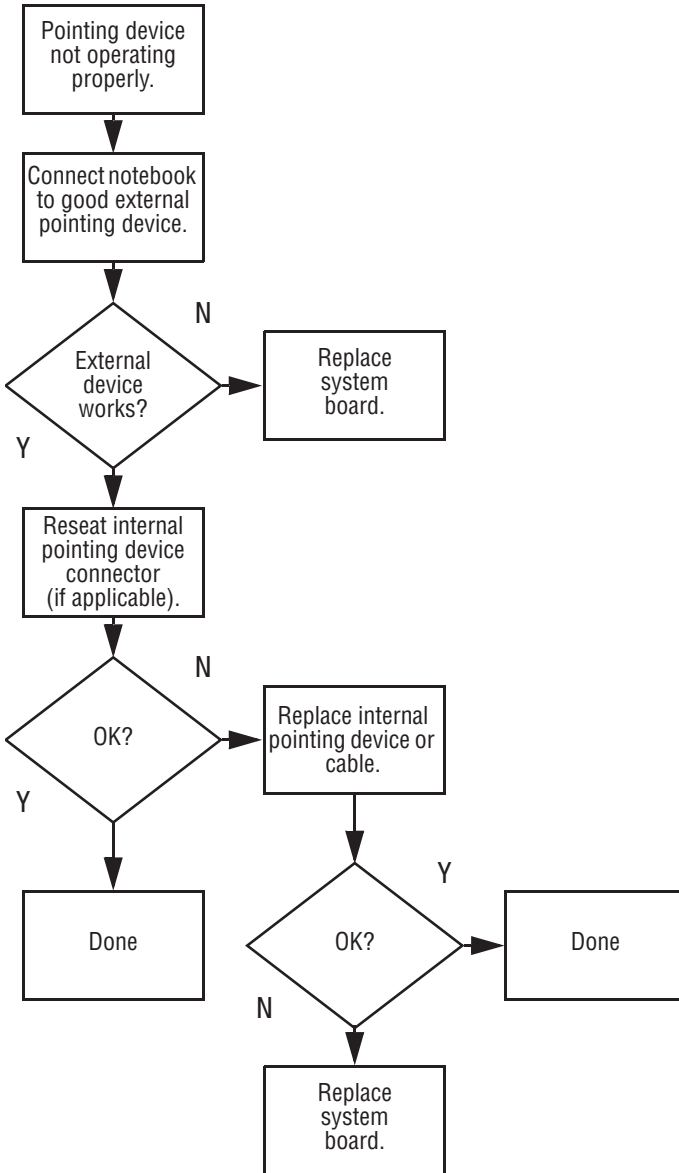

Flowchart 2.20 - Network or Modem Connection

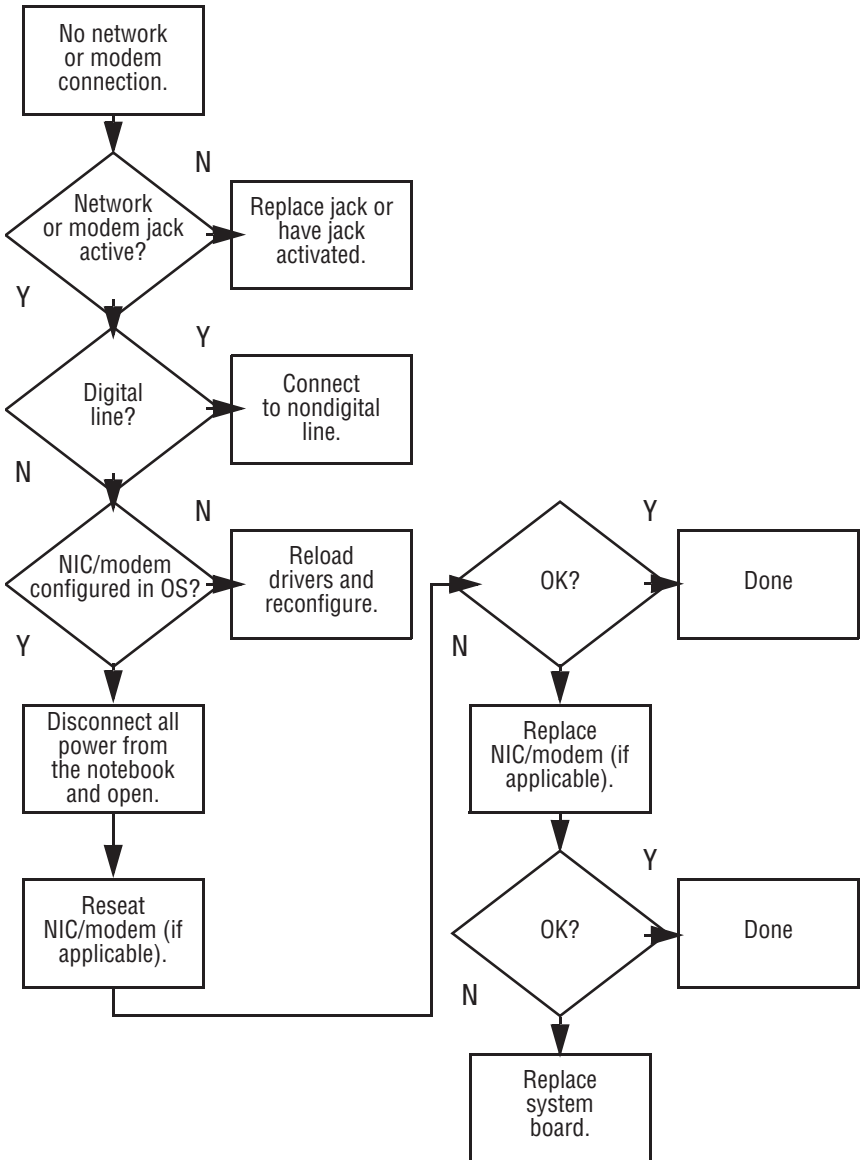

Illustrated Parts Catalog

This chapter provides an illustrated parts breakdown and a reference for spare part numbers and option part numbers.

3.1 Serial Number Location

When ordering parts or requesting information, provide the computer serial number and model number located on the bottom of the computer (Figure 3-1).



Figure 3-1. Serial Number Location

3.2 Computer System Major Components

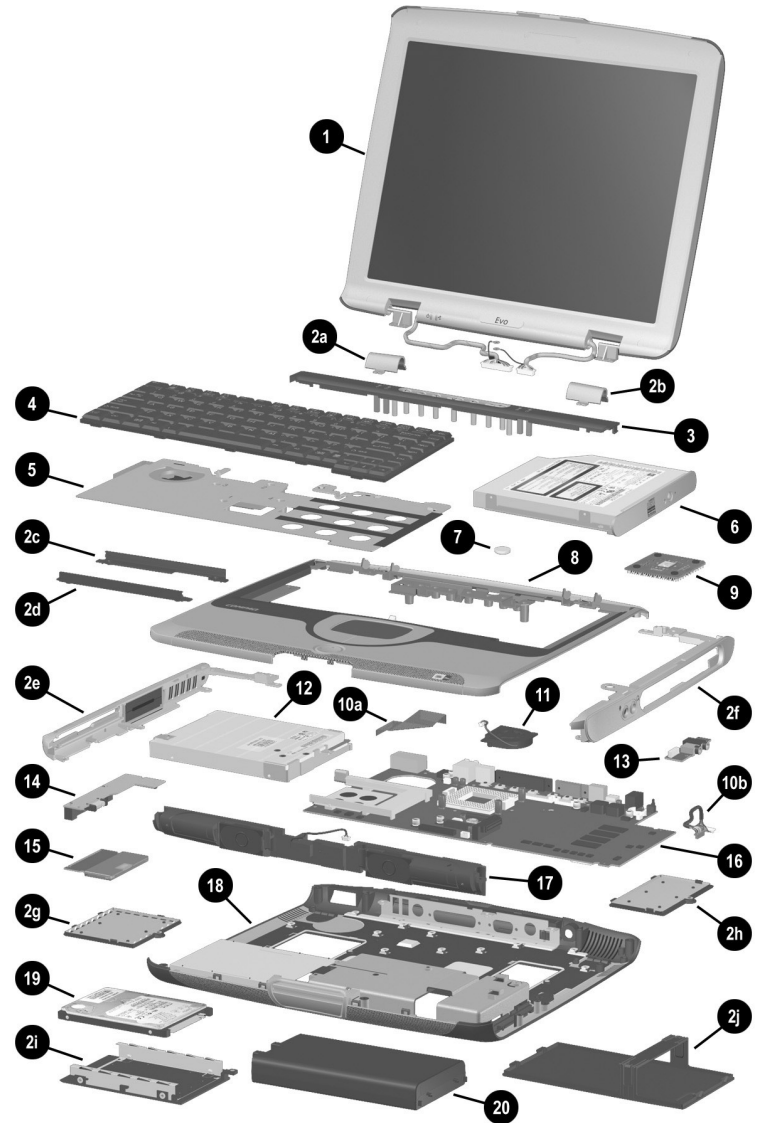
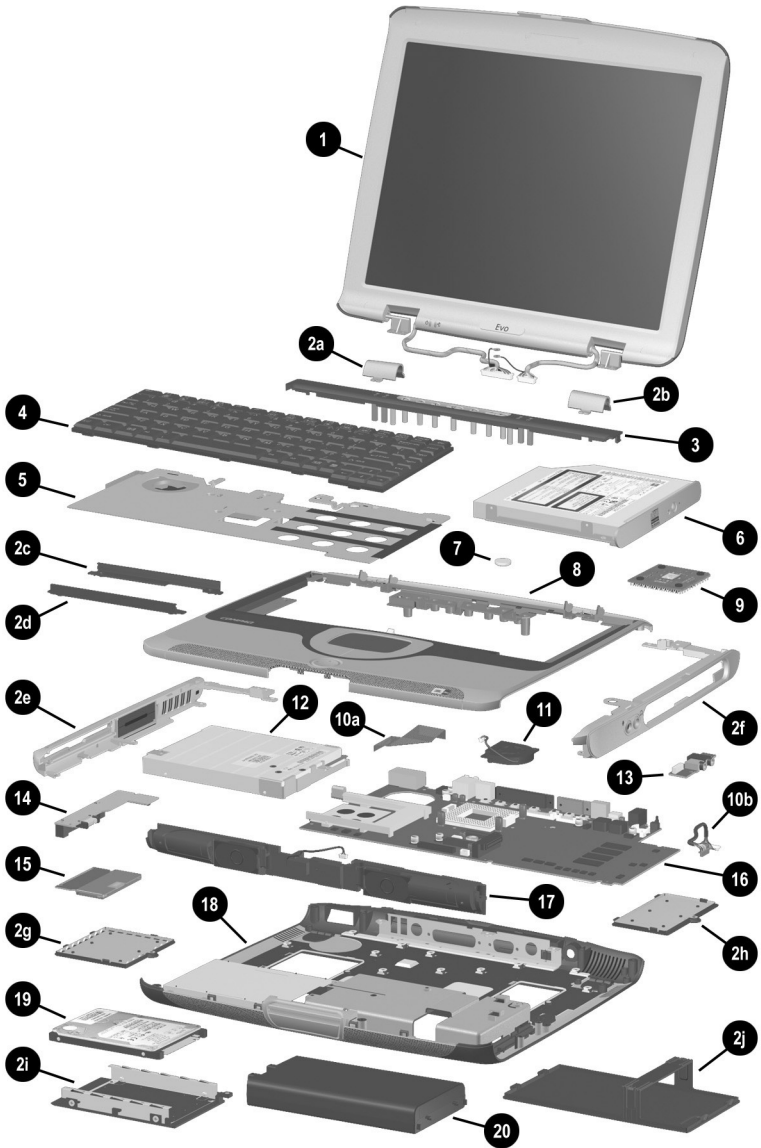

Figure 3-2. Computer System Major Components

Table 3-1
Spare Parts: Computer System Major Components

Item	Description	Spare Part Number
1	Displays	
	14.1-inch, XGA, CTFT	254108-001
	13.3-inch, XGA, CTFT	254107-001
	Plastics and Hardware Kit , includes:	254121-001
2a	Left hinge cover	
2b	Right hinge cover	
2c	Optical drive rear alignment rail	
2d	Optical drive front alignment rail	
2e	Left side panel	
2f	Right side panel	
2g	Mini PCI slot cover	
2h	Memory expansion slot cover	
2i	Hard drive bezel	
2j	Battery bracket	
3	LED cover	254117-001
4	Keyboards	
	Belgian	254114-181
	Brazilian	254114-201
	Danish	254114-081
	Dutch	254114-331
	French	
	Canadian	254114-121
	French	254114-051
	German	254114-041
	Italian	254114-061
	Japanese	254114-191
	Latin American	
	Spanish	254114-162
	Norwegian	254114-091
	Polish	254114-241
	Portuguese	254114-131
	Spanish	254114-072
	Swedish	254114-101
	Swiss	254114-111
	Taiwanese	254114-AB1
	Thai	254114-281
	U.K. English	254114-031
	U.S. English	254114-001



Computer System Major Components (continued)

Table 3-1
Spare Parts: Computer System Major Components (Continued)

Item	Description	Spare Part Number	
5	Heat spreader	254124-001	
	Thermal Pad Kit (not illustrated)	265995-001	
6	Optical drives		
	24X Max CD-ROM drive	254110-001	
	8X Max CD-RW drive	254111-001	
	8X Max DVD-ROM drive	254112-001	
	8X Max DVD-ROM/CD-RW combination drive	254113-001 and 264298-001	
7	Disk cell RTC battery	279769-001	
8	Top cover	254116-001	
9	Processors		
	AMD Mobile Athlon 4 1.1 GHz with PowerNow! technology (includes 256 KB L2 cache)	254105-001	
	AMD Mobile Athlon 4 1.0 GHz with PowerNow! technology (includes 256 KB L2 cache)	239184-001	
	AMD Mobile Athlon 4 900 MHz with PowerNow! technology (includes 256 KB L2 cache)	239182-001	
	AMD Mobile Duron 950 MHz with PowerNow! technology (includes 64 KB L2 cache)	260738-001	
	AMD Mobile Duron 900 MHz with PowerNow! technology (includes 64 KB L2 cache)	249664-001	
	AMD Mobile Duron 850 MHz with PowerNow! technology (includes 64 KB L2 cache)	239181-001	
	Processor Stopper Kit (not illustrated)	265994-001	
	Cable Kit	254120-001	
	10a	Diskette drive cable	
	10b	Audio board cable	

Table 3-1
Spare Parts: Computer System Major Components (Continued)

Item	Description	Spare Part Number
11	Fan	254123-001
12	Diskette drive	254119-001
13	Audio board	254125-001
14	Charger board	254109-001
15	Mini PCI communication boards	
	56-KBPS domestic modem	248776-001
	56-KBPS international modem	248777-002
16	System boards	
	includes 256 MB SDRAM	273487-001
	includes 128 MB SDRAM	254103-001
17	Speaker assembly	254118-001
18	Base enclosure	254115-001
19	Hard drives	
	40 GB 273491-001 15 GB	216173-001
	30 GB 192406-001 10 GB	200349-001
	20 GB 200350-001	
20	Battery packs	
	4.0 Amp hour capacity	247051-001
	3.6 Amp hour capacity	247050-001

3.3 Plastics and Hardware Kit Components

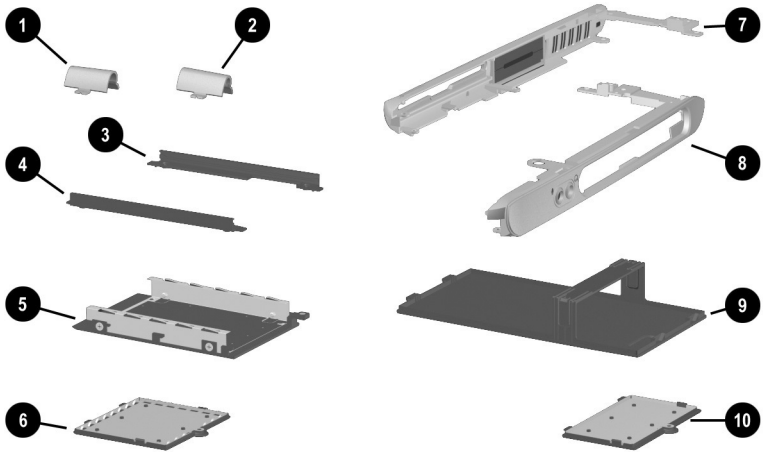

Figure 3-3. Plastics and Hardware Kit Components

**Table 3-2
Plastics and Hardware Kit Components
Spare Part Number 254121-001**

Item	Description	Item	Description
1	Left hinge cover	6	Mini PCI slot cover
2	Right hinge cover	7	Left side panel
3	Optical drive rear alignment rail	8	Right side panel
4	Optical drive front alignment rail	9	Battery bracket
5	Hard drive bezel	10	Memory expansion slot cover

3.4 Cable Kit Components

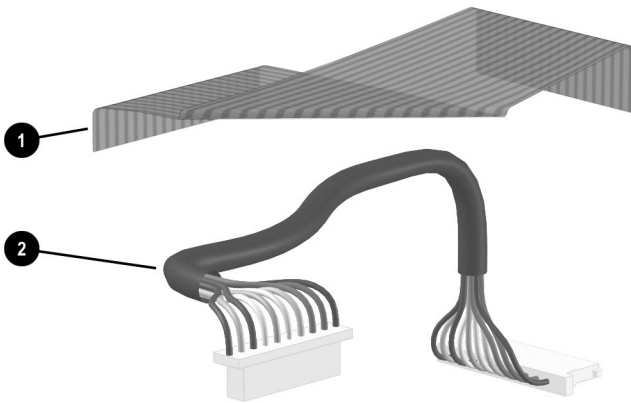

Figure 3-4. Cable Kit Components

**Table 3-3
Cable Kit Components
Spare Part Number 254120-001**

Item	Description
1	Diskette drive cable
2	Audio board cable

3.5 Mass Storage Devices

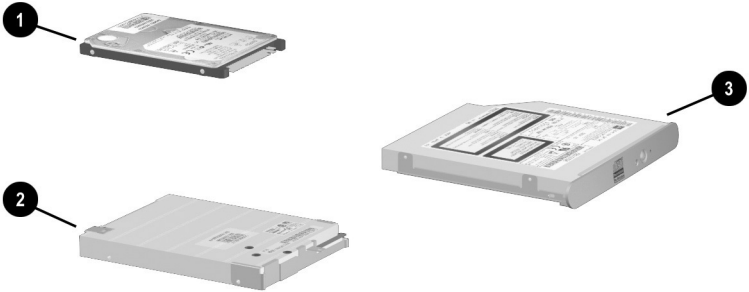

Figure 3-5. Mass Storage Devices

**Table 3-4
Mass Storage Devices**

Item	Description	Spare Part Number
1	Hard drives	
	30 GB	192406-001
	20 GB	200350-001
	15 GB	216173-001
	10 GB	200349-001

Table 3-4
Mass Storage Devices (Continued)

Item	Description	Spare Part Number
2	Diskette drive	254119-001
3	Optical drives	
	24X Max CD-ROM drive	254110-001
	8X Max CD-RW drive	254111-001
	8X Max DVD-ROM drive	254112-001
	DVD-ROM/CD-RW combination drive	254113-001
		and
		264298-001

3.6 Miscellaneous

Table 3-5
Spare Parts: Miscellaneous (not illustrated)

Description	Spare Part Number
Logo Kit	255353-001
Screw Kit (includes the following screws, standoffs, and screwlocks; refer to Appendix C, "Screw Listing," for more information on screw specifications and usage.)	254122-001
<ul style="list-style-type: none"> ■ PM2.0 x 7.0 ■ PM2.5 x 3.5 ■ PM2.0 x 5.0 ■ TM2.0 x 7.5 ■ TM2.0 x 5.0 ■ TM2.0 x 8.0 ■ TM2.0 x 20.0 ■ HM5.0 x 13.0 standoff ■ HM5.0 x 17.5 standoff ■ HM5.0 x 9.0 standoff ■ HM5.0 x 10.5 screwlock 	
AC adapters	
60-Watt AC adapter power supply (2-wire)	180676-001
60-Watt AC adapter power supply (3-wire)	180675-001
Power cord, 3-wire	
Danish	170513-081
International	170513-002
Italian	170513-061
Japanese	293831-291
Swiss	170513-115
U.K. English	170513-031
North America	293831-001
Memory expansion boards	
256 MB	244399-001
128 MB	239190-001

Removal and Replacement Preliminaries

This chapter provides essential information for proper and safe removal and replacement service.

4.1 Tools Required

You will need the following tools to complete the removal and replacement procedures:

- Magnetic screwdriver
- Phillips P0 screwdriver
- 5.0-mm hex socket (for system board screwlocks)
- Tool kit (includes connector removal tool, loopback plugs, and case utility tool)

4.2 Service Considerations

The following sections include some of the considerations that you should keep in mind during disassembly and assembly procedures.



As you remove each subassembly from the computer, place the subassembly (and all accompanying screws) away from the work area to prevent damage.

Plastic Parts

Using excessive force during disassembly and reassembly can damage plastic parts. Use care when handling the plastic parts. Apply pressure only at the points designated in the maintenance instructions.

Cables and Connectors

Cables must be handled with extreme care to avoid damage. Apply only the tension required to unseat or seat the cables during removal and insertion. Handle cables by the connector whenever possible. In all cases, avoid bending, twisting, or tearing cables. Ensure that cables are routed in such a way that they cannot be caught or snagged by parts being removed or replaced. Handle flex cables with extreme care; these cables tear easily.



CAUTION: When servicing the computer, ensure that cables are placed in their proper locations during the reassembly process. Improper cable placement can damage the computer.

4.3 Preventing Damage to Removable Drives

Removable drives are fragile components that must be handled with care. To prevent damage to the computer, damage to a removable drive, or loss of information, observe the following precautions:

- Before removing or inserting a hard drive, shut down the computer. If you are unsure whether the computer is off or in Hibernation, turn the computer on, then shut it down.
- Before removing a diskette drive or optical drive, ensure that a diskette or disc is not in the drive. Ensure that the optical drive tray is closed.
- Before handling a drive, ensure that you are discharged of static electricity. While handling a drive, avoid touching the connector.
- Handle drives on surfaces that have at least one inch of shock-proof foam.
- Avoid dropping drives from any height onto any surface.
- After removing a hard drive, CD-ROM drive, or a diskette drive, place it in a static-proof bag.
- Avoid exposing a hard drive to products that have magnetic fields, such as monitors or speakers.
- Avoid exposing a drive to temperature extremes or to liquids.
- If a drive must be mailed, place the drive in a bubble pack mailer or other suitable form of protective packaging and label the package “Fragile: Handle With Care.”

4.4 Preventing Electrostatic Damage

Many electronic components are sensitive to electrostatic discharge (ESD). Circuitry design and structure determine the degree of sensitivity. Networks built into many integrated circuits provide some protection, but in many cases the discharge contains enough power to alter device parameters or melt silicon junctions.

A sudden discharge of static electricity from a finger or other conductor can destroy static-sensitive devices or microcircuitry. Often the spark is neither felt nor heard, but damage occurs.

An electronic device exposed to electrostatic discharge may not be affected at all and can work perfectly throughout a normal cycle. Or the device may function normally for a while, then degrade in the internal layers, reducing its life expectancy.

4.5 Packaging and Transporting Precautions

Use the following grounding precautions when packaging and transporting equipment:

- To avoid hand contact, transport products in static-safe containers such as tubes, bags, or boxes.
- Protect all electrostatic-sensitive parts and assemblies with conductive or approved containers or packaging.
- Keep electrostatic-sensitive parts in their containers until the parts arrive at static-free workstations.
- Place items on a grounded surface before removing items from their containers.
- Always be properly grounded when touching a sensitive component or assembly.

- Store reusable electrostatic-sensitive parts from assemblies in protective packaging or nonconductive foam.
- Use transporters and conveyers made of antistatic belts and roller bushings. Ensure that mechanized equipment used for moving materials is wired to ground and that proper materials are selected to avoid static charging. When grounding is not possible, use an ionizer to dissipate electric charges.

4.6 Workstation Precautions

Use the following grounding precautions at workstations:

- Cover the workstation with approved static-dissipative material (refer to Table 4-2).
- Use a wrist strap connected to a properly grounded work surface and use properly grounded tools and equipment.
- Use conductive field service tools, such as cutters, screwdrivers, and vacuums.
- When using fixtures that must directly contact dissipative surfaces, only use fixtures made of static-safe materials.
- Keep the work area free of nonconductive materials such as ordinary plastic assembly aids and Styrofoam.
- Handle electrostatic-sensitive components, parts, and assemblies by the case or PCM laminate. Handle these items only at static-free workstations.
- Avoid contact with pins, leads, or circuitry.
- Turn off power and input signals before inserting or removing connectors or test equipment.

4.7 Grounding Equipment and Methods

Grounding equipment must include either a wrist strap or a foot strap at a grounded workstation.

- When seated, wear a wrist strap connected to a grounded system. Wrist straps are flexible straps with a minimum of one megohm $\pm 10\%$ resistance in the ground cords. To provide proper ground, wear a strap snugly against the skin at all times. On grounded mats with banana-plug connectors, connect a wrist strap with alligator clips.
- When standing, use foot straps and a grounded floor mat. Foot straps (heel, toe, or boot straps) can be used at standing workstations and are compatible with most types of shoes or boots. On conductive floors or dissipative floor mats, use foot straps on both feet with a minimum of one-megohm resistance between the operator and ground. To be effective, the conductive strips must be worn in contact with the skin.

Other grounding equipment recommended for use in preventing electrostatic damage includes:

- Antistatic tape
- Antistatic smocks, aprons, and sleeve protectors
- Conductive bins and other assembly or soldering aids
- Nonconductive foam
- Conductive tabletop workstations with ground cords of one-megohm resistance
- Static-dissipative tables or floor mats with hard ties to the ground
- Field service kits
- Static awareness labels
- Material-handling packages

- Nonconductive plastic bags, tubes, or boxes
- Metal tote boxes
- Electrostatic voltage levels and protective materials

Table 4-1 shows how humidity affects the electrostatic voltage levels generated by different activities.

Table 4-1
Typical Electrostatic Voltage Levels

Event	Relative Humidity		
	10%	40%	55%
Walking across carpet	35,000 V	15,000 V	7,500 V
Walking across vinyl floor	12,000 V	5,000 V	3,000 V
Motions of bench worker	6,000 V	800 V	400 V
Removing DIPS from plastic tube	2,000 V	700 V	400 V
Removing DIPS from vinyl tray	11,500 V	4,000 V	2,000 V
Removing DIPS from Styrofoam	14,500 V	5,000 V	3,500 V
Removing bubble pack from PCB	26,500 V	20,000 V	7,000 V
Packing PCBs in foam-lined box	21,000 V	11,000 V	5,000 V

 A product can be degraded by as little as 700 volts.

Table 4-2 lists the shielding protection provided by antistatic bags and floor mats.

Table 4-2
Static-Shielding Materials

Material	Use	Voltage Protection Level
Antistatic plastic	Bags	1,500 V
Carbon-loaded plastic	Floor mats	7,500 V
Metallized laminate	Floor mats	5,000 V

Removal and Replacement Procedures

This chapter provides removal and replacement procedures.

Phillips P1 and Torx T8 screws are removed during disassembly. There are 62 screws, standoffs, and screwlocks, in 11 different sizes, that must be removed and replaced when servicing the computer. Make special note of each screw size and location during removal and replacement.

Refer to Appendix C, “Screw Listing,” for detailed information on screw sizes, locations, and usage.

5.1 Serial Number

Report the computer serial number to Compaq when requesting information or ordering spare parts. The serial number is located on the bottom of the computer (Figure 5-1).



Figure 5-1. Serial Number Location

5.2 Disassembly Sequence Chart

Use the chart below to determine the section number to be referenced when removing computer components.

Table 5-1
Disassembly Sequence Chart

Section	Description	# of Screws Removed
5.3	Preparing the computer for disassembly	
	Battery pack	0
	Hard drive	1 to remove hard drive 4 to separate hard drive from hard drive bracket
5.4	Computer feet	0
5.5	Memory expansion board	1
5.6	Mini PCI communications board	1
5.7	Optical Drive	2
5.8	LED cover	2
5.9	Keyboard	0
5.10	Display	7
5.11	Heat spreader	7

Table 5-1
Disassembly Sequence Chart (Continued)

Section	Description	# of Screws Removed
5.12	Processor	0
5.13	Disk cell RTC battery	0
5.14	Top cover	12
5.15	Diskette drive	1
5.16	Charger board	1
5.17	Left side panel	3 screws 1 standoff
5.18	Right side panel	3
5.19	Speaker assembly	0
5.20	Audio board	2
5.21	Fan	2
5.22	System board	5 screws 3 standoffs 4 screwlocks

5.3 Preparing the Computer for Disassembly

Perform the following steps before disassembling the computer:

1. Turn off the computer.
2. Disconnect the AC adapter and all external devices.

3. Remove the battery pack by following these steps:
 - a. Turn the computer bottom side up with the front facing forward.
 - b. Slide and hold the battery release latch ❶ toward the back of the computer (Figure 5-2). The left edge of the battery bracket rises up ❷.



Figure 5-2. Releasing the Battery Pack

- c. Lift and hold the battery bracket open as far as it will open ❶ (Figure 5-3).
- d. Grasp the edges of the battery pack and slide it to the left to remove it ❷.

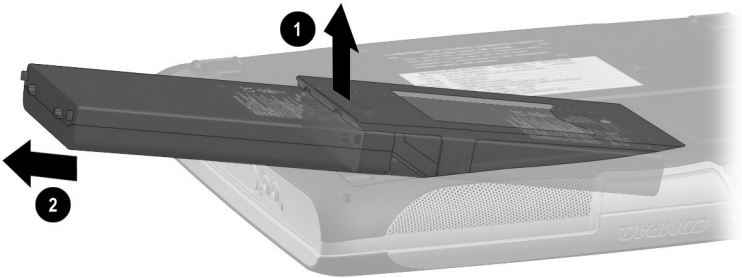

Figure 5-3. Removing the Battery Pack

- e. Press in on the tabs on the battery bracket retention arms ❶ and swing the battery bracket up and to the right ❷ (Figure 5-4).
- f. Lift the battery bracket straight up to remove it ❸.

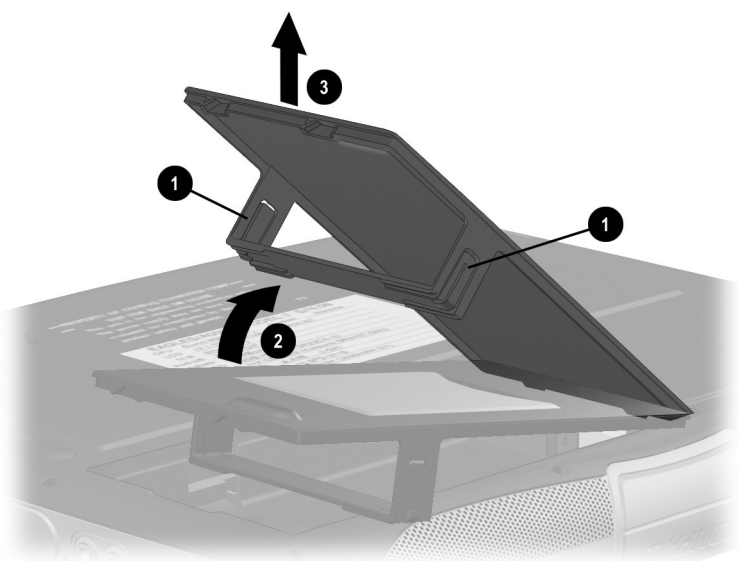

Figure 5-4. Removing the Battery Bracket



The battery bracket is included in the Plastics and Hardware Kit (spare part number 254121-001).

Reverse the above procedures to install the battery pack and battery bracket.

4. Remove the hard drive by following these steps:
 - a. Remove the battery pack (Section 5.3).
 - b. Remove the black PM2.0 × 7.0 hard drive retention screw ❶ (Figure 5-5).
 - c. Slide the hard drive to the right to unseat the hard drive connector ❷.

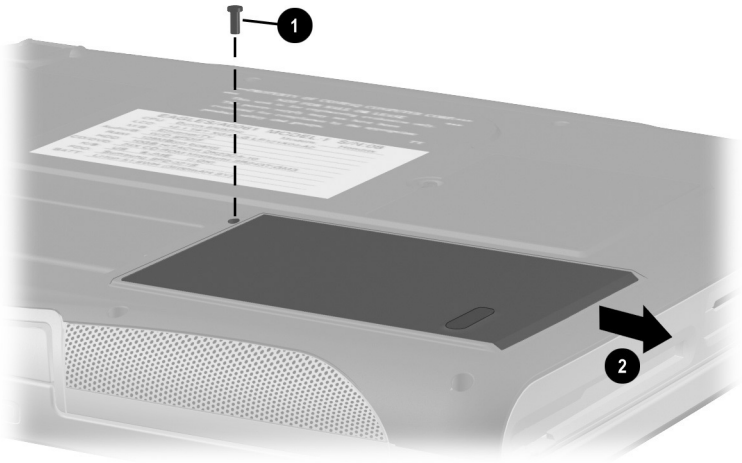

Figure 5-5. Releasing the Hard Drive

- d. Swing the right side of the hard drive up and to the left until it is resting at an angle (Figure 5-6).
- e. Lift the hard drive straight up and remove it ②.

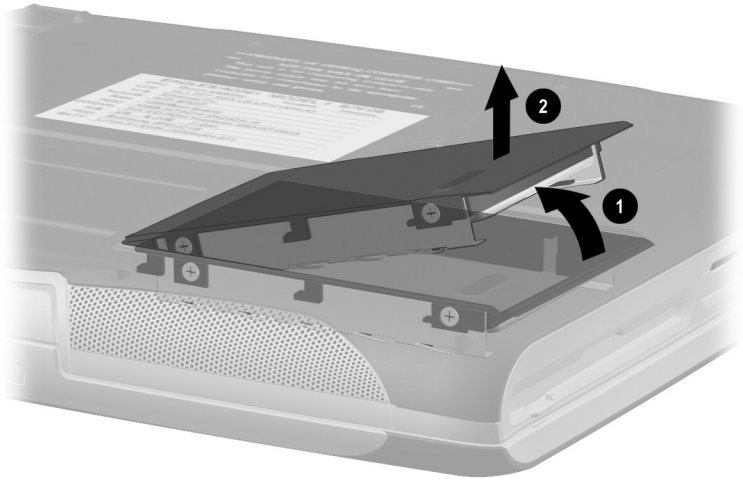

Figure 5-6. Removing the Hard Drive

5. If the hard drive must be removed from the hard drive bezel, perform the following steps:
 - a. Remove the four silver PM2.5 × 3.5 screws ❶ that secure the hard drive to the hard drive bezel (Figure 5-7).
 - b. Slide the hard drive forward ❷ and remove it from the hard drive bezel.

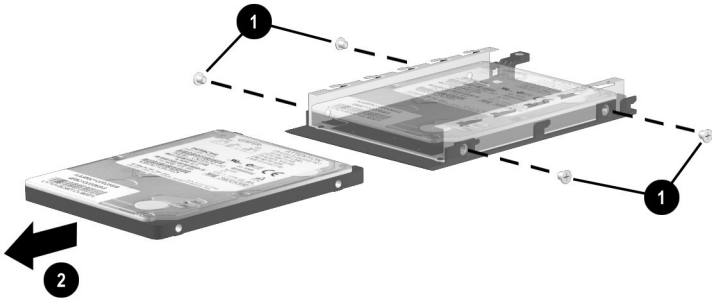

Figure 5-7. Removing the Hard Drive from the Hard Drive Bezel



The hard drive bezel is included in the Plastics and Hardware Kit (spare part number 254121-001).

Reverse the above procedure to install the hard drive.

5.4 Computer Feet

The computer feet are adhesive-backed rubber pads. The computer feet are included in the Plastics and Hardware Kit (spare part number 254121-001). The computer feet attach to the battery bracket and hard drive bezel as illustrated in Figure 5-8.

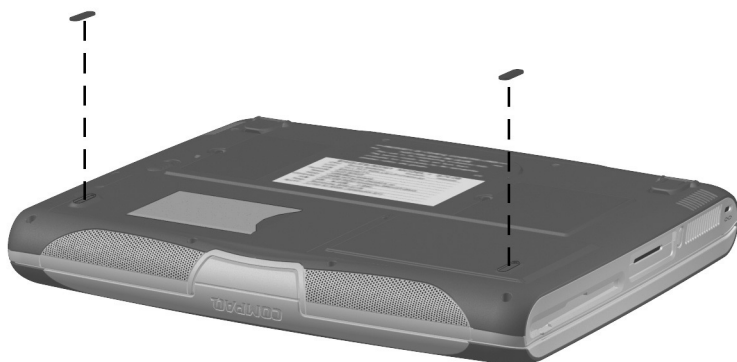

Figure 5-8. Replacing the Computer Feet

5.5 Memory Expansion Board

Memory Expansion Boards Spare Part Number Information

Memory expansion boards

256 MB	244399-001
128 MB	239190-001

1. Prepare the computer for disassembly (Section 5.3).
2. Turn the computer bottom side up with the front facing forward.
3. Remove the black PM2.0 × 5.0 screw ❶ that secures the memory expansion compartment cover to the base enclosure (Figure 5-9).
4. Swing the left side of the cover up and to the right until it rests at an angle ❷.
5. Lift the cover straight up and remove it ❸.

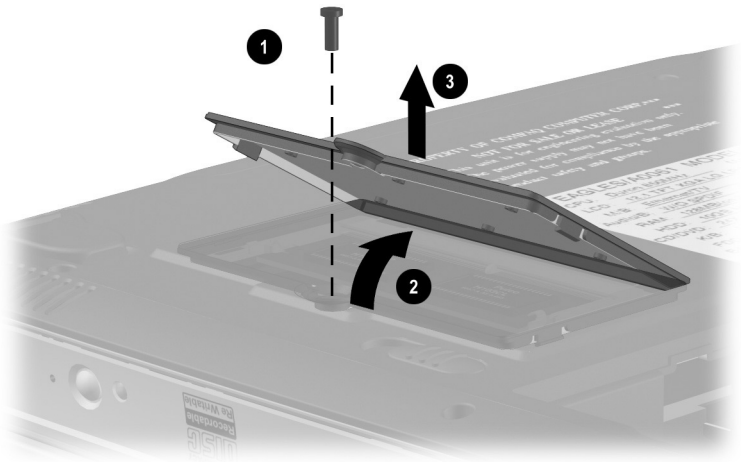

Figure 5-9. Removing the Memory Expansion Compartment Cover



The memory expansion compartment cover is included in the Plastics and Hardware Kit (spare part number 254121-001).

6. Spread the memory expansion slot retaining tabs to release the memory expansion board ❶. The board tilts up at a 45-degree angle (Figure 5-10).
7. Remove the board by pulling it away from the connector at a 45-degree angle ❷.

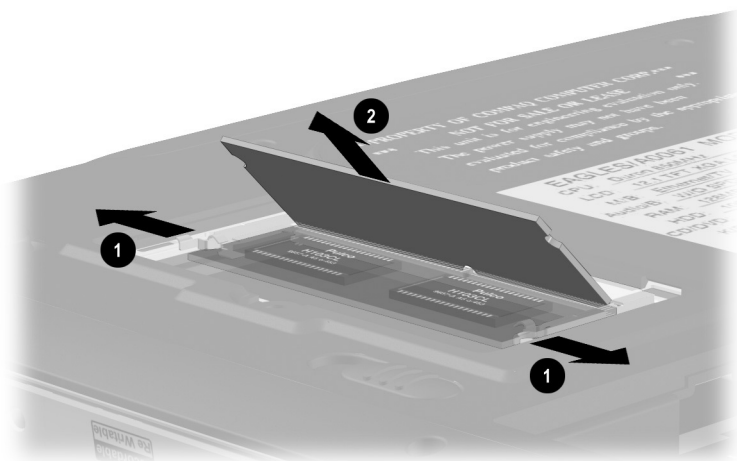

Figure 5-10. Removing a Memory Expansion Board

Reverse the above procedure to install a memory expansion board.

5.6 Mini PCI Communications Board

Mini PCI Communication Boards Spare Part Number Information

Mini PCI communication boards

56-KBPS domestic modem	248776-001
56-KBPS international modem	248777-002

1. Prepare the computer for disassembly (Section 5.3).
2. Turn the computer bottom side up with the front facing forward.
3. Remove the black PM2.0 × 5.0 screw ❶ that secures the mini PCI communications slot cover to the base enclosure (Figure 5-11).
4. Swing the left side of the cover up and to the right until it rests at an angle ❷.
5. Lift the cover straight up and remove it ❸.



The mini PCI communications slot cover is included in the Plastics and Hardware Kit (spare part number 254121-001).

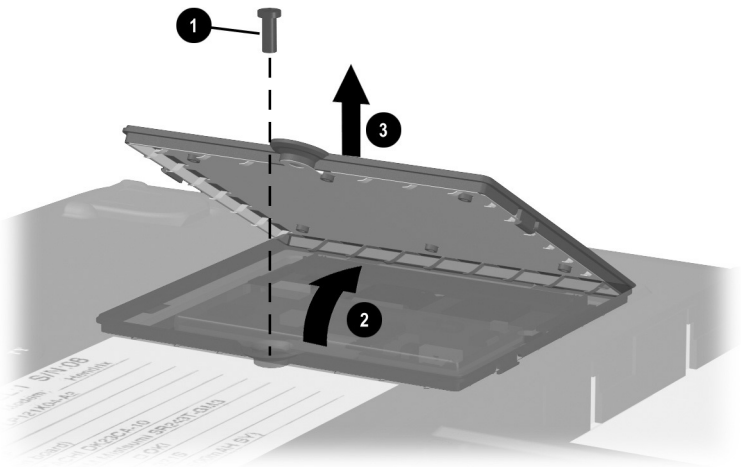

Figure 5-11. Removing the Mini PCI Communications Slot Cover

6. Spread the retaining tabs to release the mini PCI communications board ❶. The board tilts up at a 45-degree angle (Figure 5-12).
7. Remove the board by pulling it away from the connector at a 45-degree angle ❷.

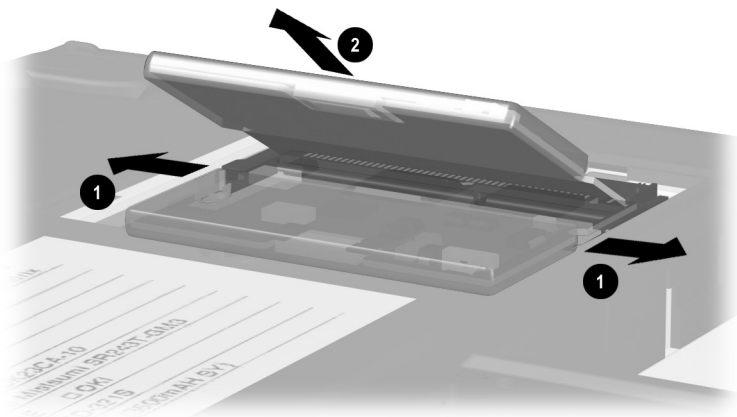

Figure 5-12. Removing a Mini PCI Communications Board

Reverse the above procedure to install a mini PCI communications board.

5.7 Optical Drive

Optical Drives Spare Part Number Information

Optical drives

24X Max CD-ROM drive	254110-001
8X Max CD-RW drive	254111-001
8X Max DVD-ROM drive	254112-001
8X Max DVD-ROM/CD-RW combination drive	254113-001 and 264298-001

1. Prepare the computer for disassembly (Section 5.3).
2. Turn the computer bottom side up with the front facing forward.
3. Remove the two pewter TM2.0 × 7.5 screws that secure the optical drive to the base enclosure (Figure 5-13).



Figure 5-13. Removing the Optical Drive Screws

4. Turn the computer top side up with the front facing forward.
5. Insert a paper clip or similar thin metal rod into the manual release hole on the front bezel of the optical drive ❶ (Figure 5-14). Press firmly.
6. Grasp the drive bezel and slide the drive out of the optical drive bay ❷.



Figure 5-14. Removing the Optical Drive

Reverse the above procedure to install the optical drive.

5.8 LED Cover

LED Cover Spare Part Number Information

LED cover	254117-001
-----------	------------

1. Prepare the computer for disassembly (Section 5.3).
2. Turn the computer bottom side up with the rear panel facing forward.
3. Remove the two pewter TM2.0 × 7.5 screws that secure the LED cover to the base enclosure (Figure 5-15).

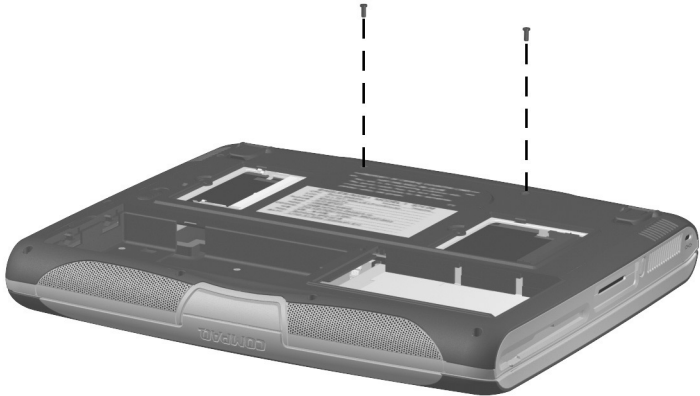

Figure 5-15. Removing the LED Cover Screws

4. Turn the computer top side up with front facing forward.
5. Open the computer as far as it will open.

6. Press the **Esc** and **F1** keys to reveal the slot in the LED cover ❶ (Figure 5-16).
7. Insert a flat-bladed tool into the slot in the LED cover and lift the left side of the LED cover up ❷.
8. Lift the LED cover up from left to right ❸.

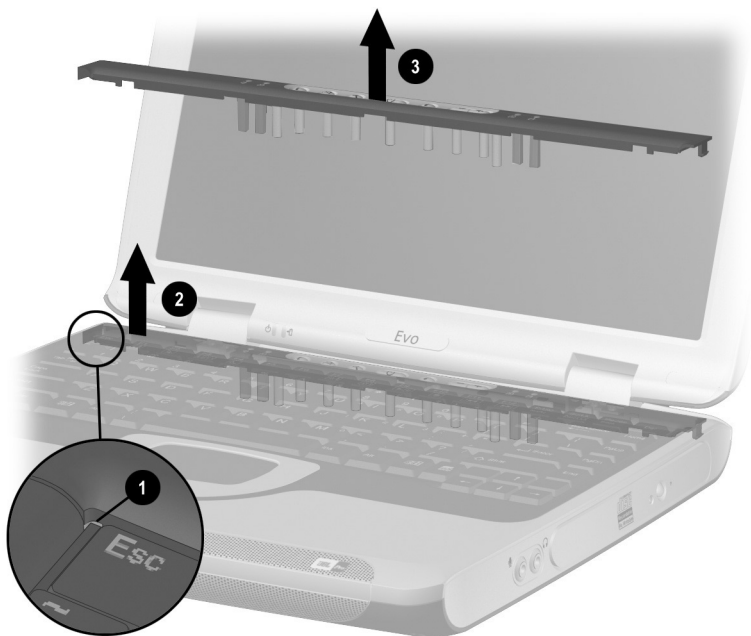

Figure 5-16. Removing the LED Cover

9. Remove the LED cover.

Reverse the above procedure to install the LED cover.

5.9 Keyboard

Keyboards Spare Part Number Information

Keyboards

Belgian	254114-181	Norwegian	254114-091
Brazilian	254114-201	Polish	254114-241
Danish	254114-081	Portuguese	254114-131
Dutch	254114-331	Spanish	254114-072
French Canadian	254114-121	Swedish	254114-101
French	254114-051	Swiss	254114-111
German	254114-041	Taiwanese	254114-AB1
Italian	254114-061	Thai	254114-281
Japanese	254114-191	U.K. English	254114-031
Latin American	254114-162	U.S. English	254114-001
Spanish			

1. Prepare the computer for disassembly (Section 5.3).
2. Remove the LED cover (Section 5.8).

3. Swing the back edge of the keyboard up and forward ❶ and rest it upside down on the palm rest ❷ (Figure 5-17).

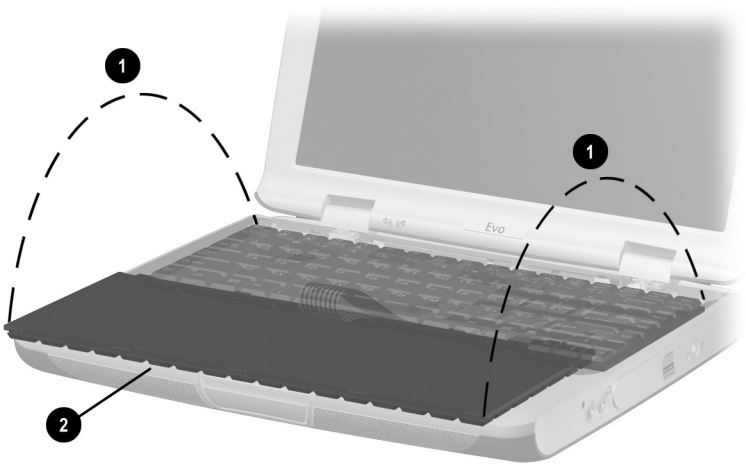

Figure 5-17. Releasing the Keyboard

4. Release the ZIF connector ❶ to which the keyboard cable is connected and disconnect the keyboard cable ❷ (Figure 5-18).

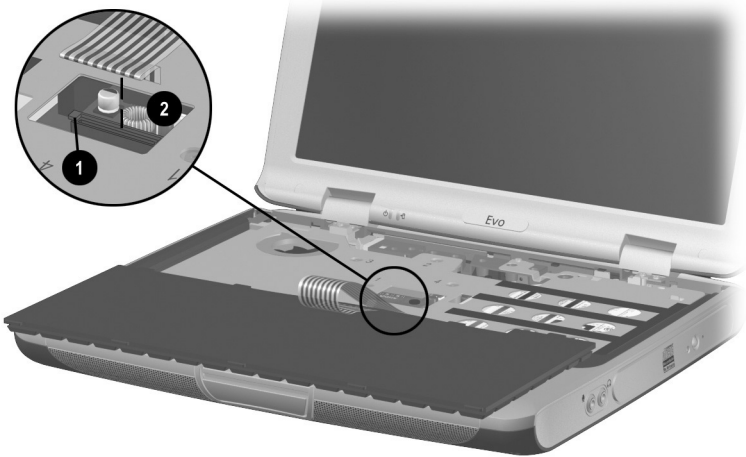

Figure 5-18. Disconnecting the Keyboard Cable

5. Remove the keyboard.

Reverse the above procedure to install the keyboard.

5.10 Display

Displays Spare Part Number Information

Displays

14.1-inch, XGA, CTFT	254108-001
13.3-inch, XGA, CTFT	254107-001

1. Prepare the computer for disassembly (Section 5.3).
2. Remove the LED cover (Section 5.8).
3. Remove the keyboard (Section 5.9).
4. Remove the two silver TM2.0 × 5.0 screws ❶ that secure the hinge covers to the base enclosure (Figure 5-19).
5. Lift the front edge of the hinge cover ❷ until it separates from the base enclosure.

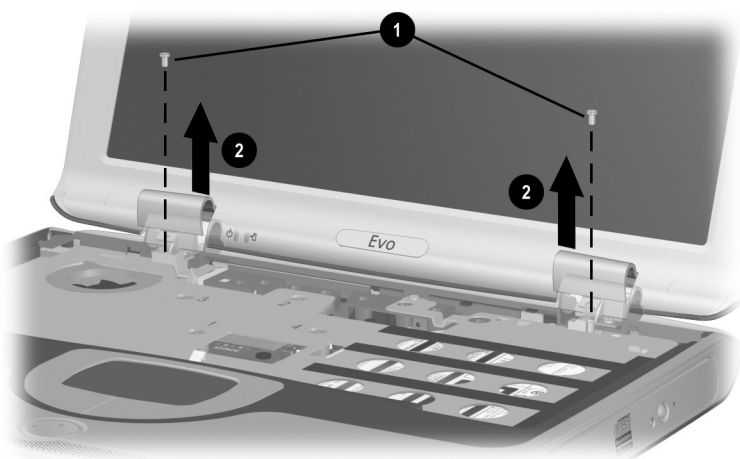

Figure 5-19. Removing the Hinge Cover Screws

6. Position the display so it rests at a 90-degree angle in relationship to the work surface.

7. Press forward on the back of the hinge cover ❶ (Figure 5-20).
8. Remove the hinge cover ❷.



The display hinge covers are included in the Plastics and Hardware Kit (spare part number 254121-001).

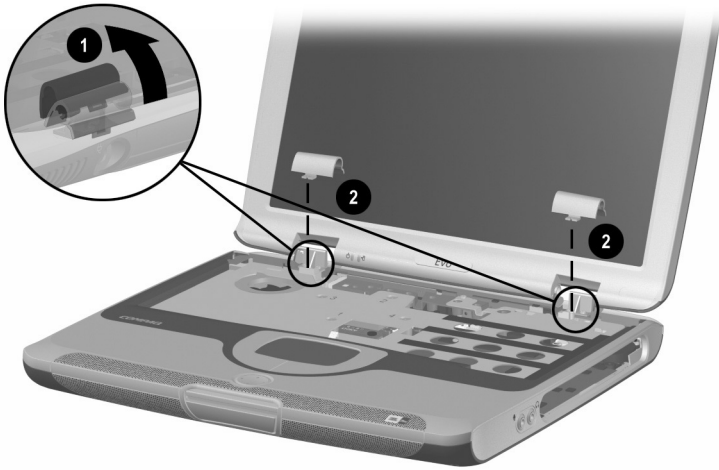

Figure 5-20. Removing the Hinge Covers

9. Remove the pewter TM2.0 × 7.5 screw ❶ that secures the display backlight ❷ and display video ground cables ❸ to the heat spreader (Figure 5-21).

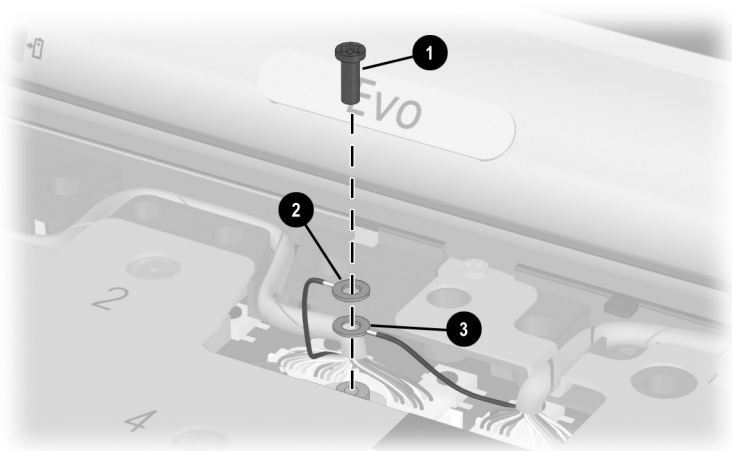

Figure 5-21. Removing the Display Ground Cable Screw

10. Disconnect the display backlight cable ❶ from the system board and unroute the cable ❷ from the heat spreader.
11. Disconnect the display video cable ❸ from the system board and unroute the cable ❹ from the heat spreader (Figure 5-22).

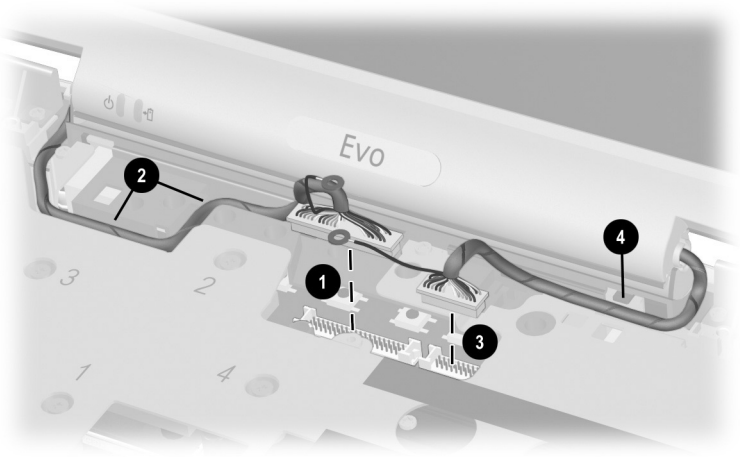



Figure 5-22. Disconnecting and Unrouting the Display Cables

12. Remove the four silver TM2.0 × 8.0 screws ❶ that secure the display to the base enclosure.

 **CAUTION:** Secure the display when removing these screws. The display is secured to the computer only by these screws and will fall if not supported during screw removal.

13. Remove the display ❷ (Figure 5-23).

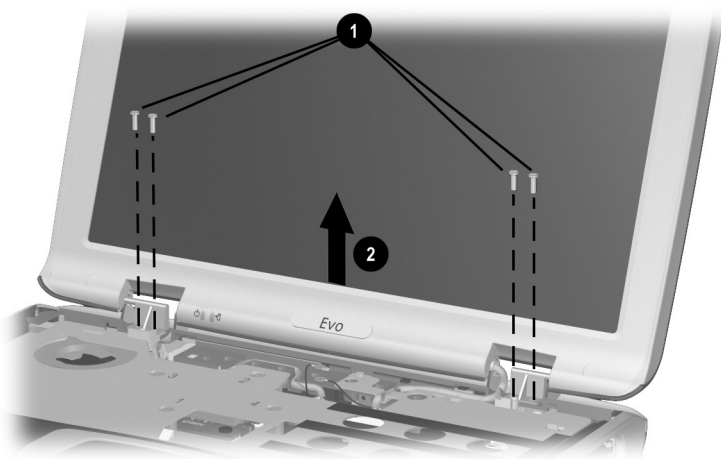

Figure 5-23. Removing the Display

When installing the display, install the screws in the ❶, ❷, ❸, ❹ sequence shown in the Figure 5-24.

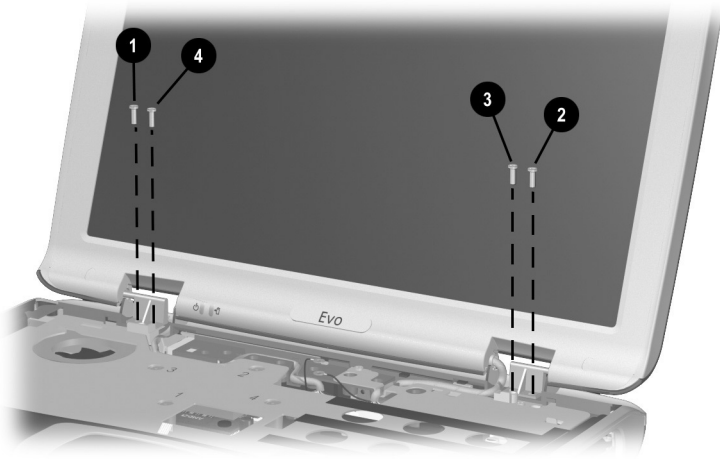

Figure 5-24. Installing the Display Screws

5.11 Heat Spreader

Heat Spreader Spare Part Number Information

Heat spreader

254124-001

1. Prepare the computer for disassembly (Section 5.3) and remove the following components:
 - a. LED cover (Section 5.8)
 - b. Keyboard (Section 5.9)
 - c. Display (Section 5.10)

2. Remove the three silver TM2.0 \times 5.0 screws ❶ that secure the heat spreader to the base enclosure (Figure 5-25).
3. Remove the four silver TM2.0 \times 20.0 spring-loaded screws ❷ that secure the heat spreader to the base enclosure.

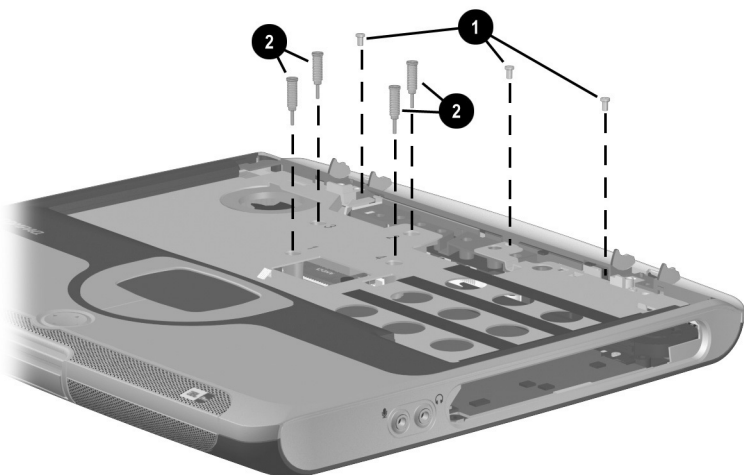

Figure 5-25. Removing the Heat Spreader Screws



The spring-loaded screws should be removed and installed in the **1, 2, 3, 4** sequence stamped into the heat spreader as illustrated in Figure 5-26.

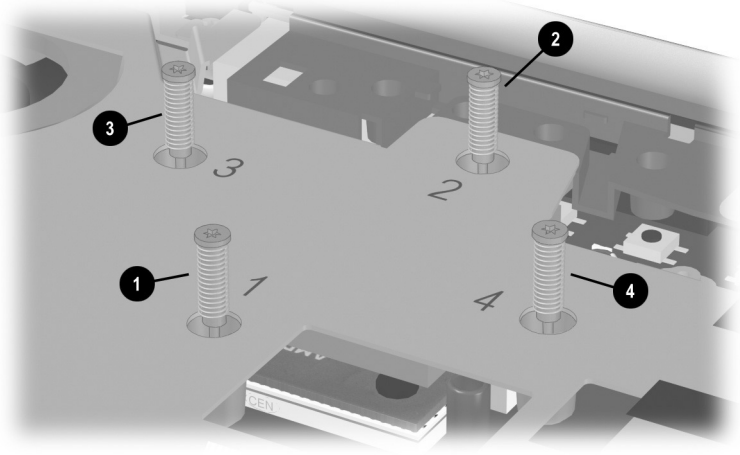

Figure 5-26. Heat Spreader Screw Sequence

4. Lift up the front right side of the heat spreader ❶ and slide it forward ❷ until the back edge of the heat spreader clears the tab ❸ on the base enclosure (Figure 5-27).

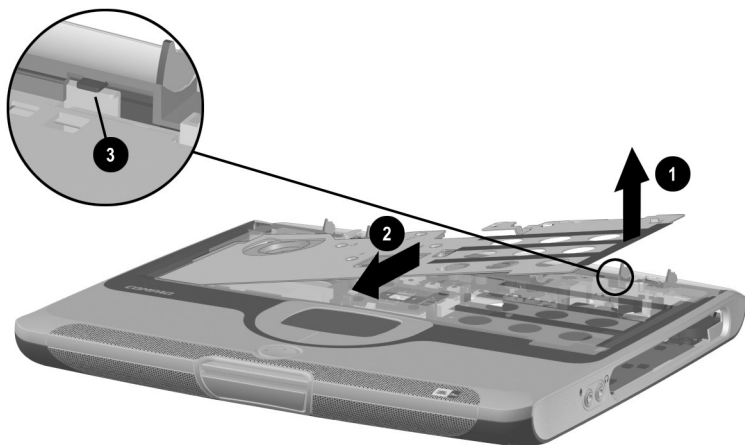

Figure 5-27. Removing the Heat Spreader

5. Lift up the right side of the heat spreader ❶ until it rests at an angle (Figure 5-28).
6. Slide the heat spreader to the right ❷ until the left side of the heat spreader clears the base enclosure.
7. Slide the heat spreader forward ❸ and rest it on the palm rest.
8. Disconnect the fan cable ❹ from the system board.

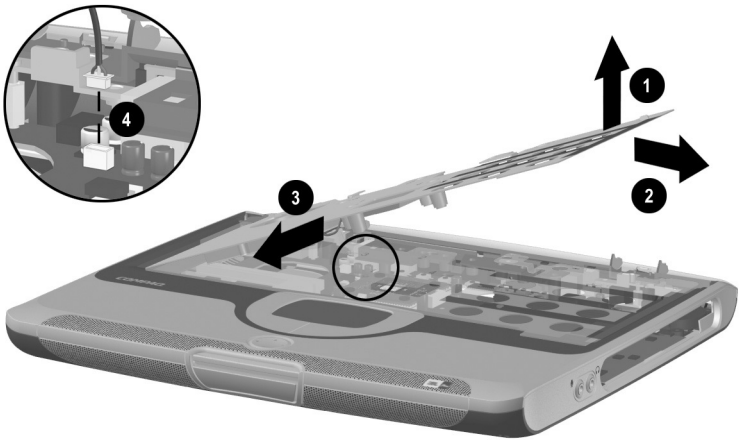

Figure 5-28. Removing the Heat Spreader (Continued)

9. Remove the heat spreader.



The heat spreader thermal pad should be replaced every time the processor is replaced. Refer to Figure 5-29 for the location of the thermal pad. The Thermal Pad Kit spare part number is 265995-001.

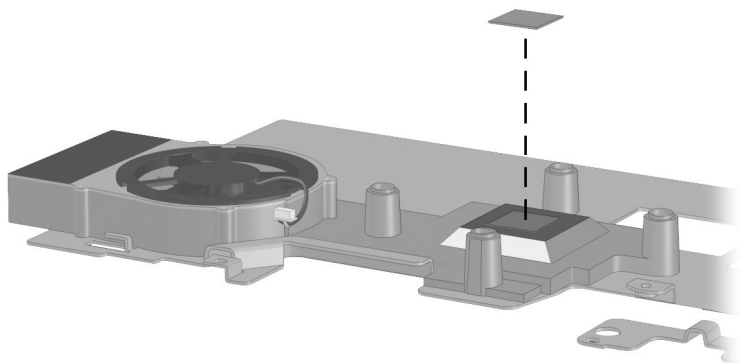

Figure 5-29. Replacing the Thermal Pad

5.12 Processor

Processors Spare Part Number Information

Processors

AMD Mobile Athlon 4 1.1 GHz with PowerNow! technology (includes 256 KB L2 cache)	254105-001
AMD Mobile Athlon 4 1.0 GHz with PowerNow! technology (includes 256 KB L2 cache)	239184-001
AMD Mobile Athlon 4 900 MHz with PowerNow! technology (includes 256 KB L2 cache)	239182-001
AMD Mobile Duron 950 MHz with PowerNow! technology (includes 64 KB L2 cache)	260738-001
AMD Mobile Duron 900 MHz with PowerNow! technology (includes 64 KB L2 cache)	249664-001
AMD Mobile Duron 850 MHz with PowerNow! technology (includes 64 KB L2 cache)	239181-001
Processor Stopper Kit (not illustrated)	265994-001



CAUTION: Before removing the processor, make special note of the orientation of the printing on the processor. The processor must be installed in the same orientation in which it was removed.

1. Prepare the computer for disassembly (Section 5.3) and remove the following components:
 - a. Optical drive device (Section 5.7)
 - b. LED cover (Section 5.8)
 - c. Keyboard (Section 5.9)
 - d. Display (Section 5.10)
 - e. Heat spreader (Section 5.11)

2. If a stopper ❶ is installed in the left slot (marked “Lock”), remove it (Figure 5-30).
3. Insert a flat-bladed tool into the right slot (marked “Open”) ❷.
4. Swing the tool to the left ❸ to unseat the processor from the socket on the system board.
5. Lift the processor straight up and remove it ❹.

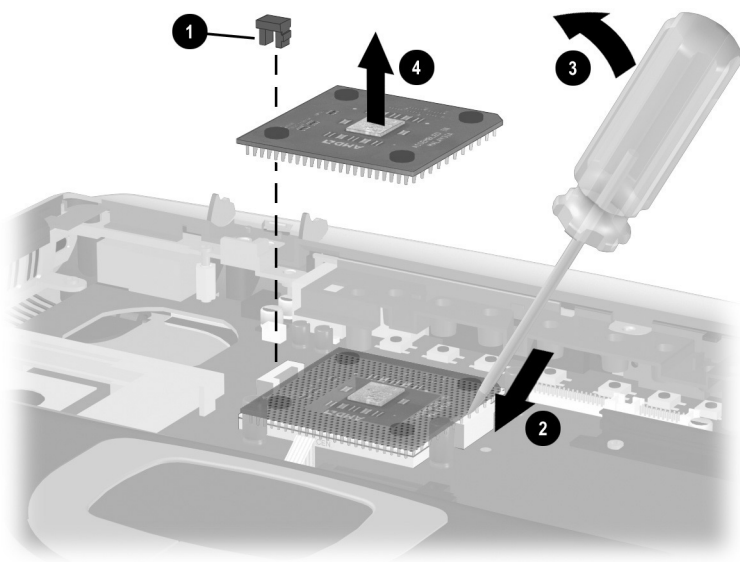

Figure 5-30. Removing the Processor

When installing the processor, insert a flat-bladed tool in the left “Lock” slot ❶ (Figure 5-31). Swing the tool to the right ❷ to seat the processor in the socket on the system board.

If the processor socket has the letters “CEN” ❸ printed on the front, install a stopper ❹ into the “Lock” slot.

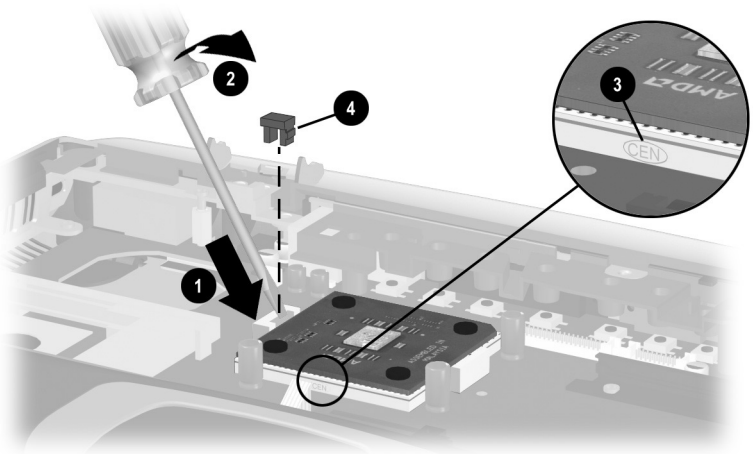

Figure 5-31. Installing the Processor

5.13 Disk Cell RTC Battery

Disk Cell RTC Battery Spare Part Number Information

Disk cell RTC battery

279769-001

1. Prepare the computer for disassembly (Section 5.3) and remove the following components:
 - a. Optical drive (Section 5.7)
 - b. LED cover (Section 5.8)

- c. Keyboard (Section 5.9)
 - d. Display (Section 5.10)
 - e. Heat spreader (Section 5.11)
2. Use a flat-bladed tool to remove the RTC battery from the socket in the system board (Figure 5-32).

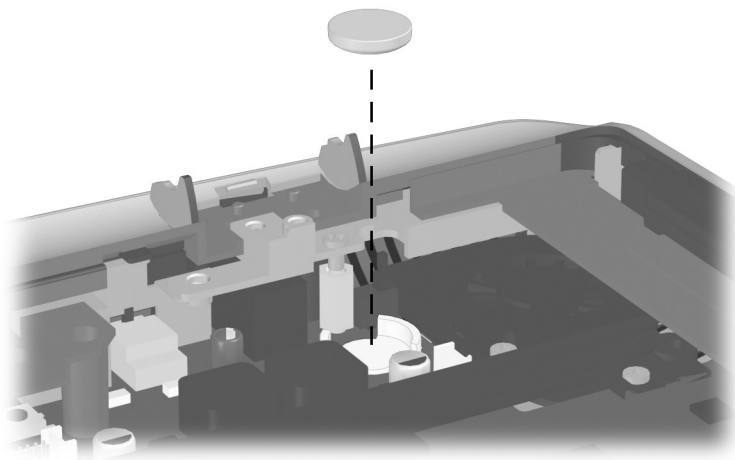

Figure 5-32. Removing the Disk Cell RTC Battery



When replacing an RTC battery, insert the battery with the “+” sign facing up.

5.14 Top Cover

Top Cover Spare Part Number Information

Top cover

254116-001

1. Prepare the computer for disassembly (Section 5.3) and remove the following components:
 - a. Optical drive (Section 5.7)
 - b. LED cover (Section 5.8)
 - c. Keyboard (Section 5.9)
 - d. Display (Section 5.10)
 - e. Heat spreader (Section 5.11)
2. Turn the computer bottom side up with the front facing forward.

3. Remove the six pewter TM2.0 × 7.5 screws ❶ that secure the top cover to the base enclosure (Figure 5-33).
4. Remove the three silver TM2.0 × 5.0 screws ❷ in the battery bay that secure the top cover to the base enclosure.

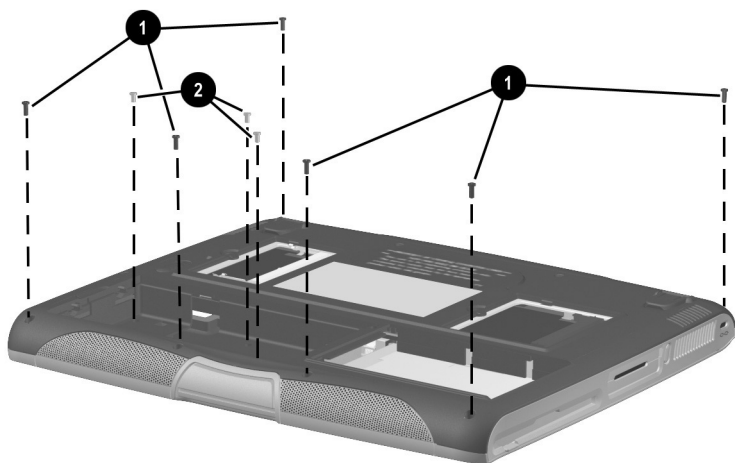

Figure 5-33. Removing the Top Cover Screws

5. Turn the computer top side up with the front facing forward.
6. Disconnect the TouchPad cable ❶ from the low insertion force (LIF) connector on the system board (Figure 5-34).
7. Remove the two silver TM2.0 × 5.0 screws ❷ and the pewter TM2.0 × 7.5 screw ❸ that secure the top cover to the base enclosure.

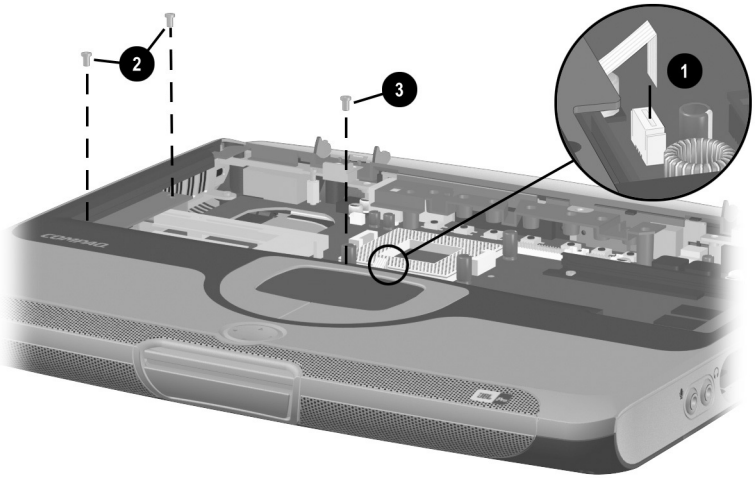

Figure 5-34. Disconnecting the TouchPad Cable and Removing the Top Cover Screws

8. Swing the back edge of the top cover up and forward until the front edge of the top cover disengages from the base enclosure (Figure 5-35).

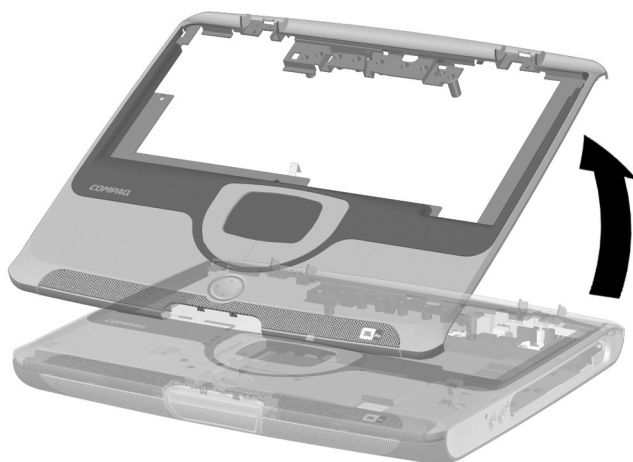

Figure 5-35. Removing the Top Cover

9. Remove the top cover.

Reverse the above procedure to install the top cover.

5.15 Diskette Drive

Diskette Drive Spare Part Number Information

Diskette drive

254119-001

1. Prepare the computer for disassembly (Section 5.3) and remove the following components:
 - a. Optical drive (Section 5.7)
 - b. LED cover (Section 5.8)
 - c. Keyboard (Section 5.9)
 - d. Display (Section 5.10)
 - e. Heat spreader (Section 5.11)
 - f. Top cover (Section 5.14)

2. Release the ZIF connector ❶ to which the diskette drive cable is connected and disconnect the cable ❷ from the system board (Figure 5-36).
3. Remove the silver TM2.0 × 5.0 screw ❸ that secures the diskette drive to the base enclosure.

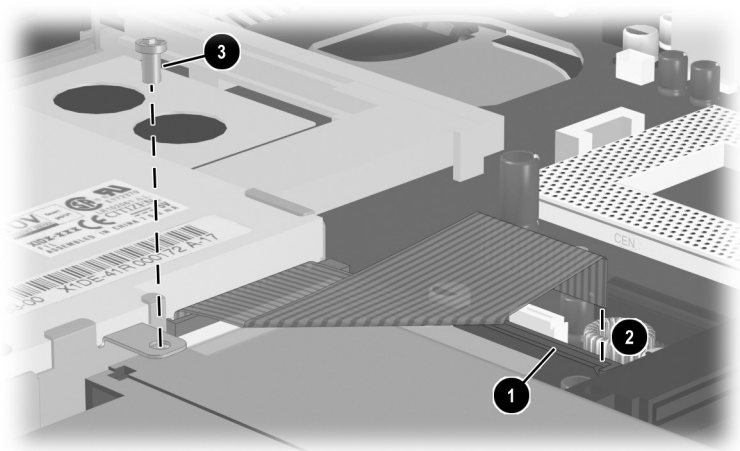

Figure 5-36. Disconnecting the Diskette Drive Cable and Removing the Diskette Drive Screws

4. Lift up the right side of the diskette drive ❶ until the drive rests an angle (Figure 5-37).
5. Slide the diskette drive to the right ❷ and remove it from the base enclosure.

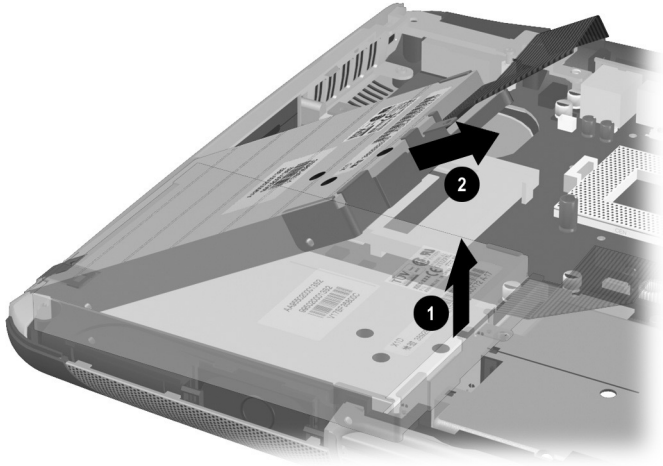

Figure 5-37. Removing the Diskette Drive

6. Release the ZIF connector ❶ to which the diskette drive cable is connected and disconnect the cable from the diskette drive ❷ (Figure 5-38).



The diskette drive cable is included in the Cable Kit (spare part number 254120-001).

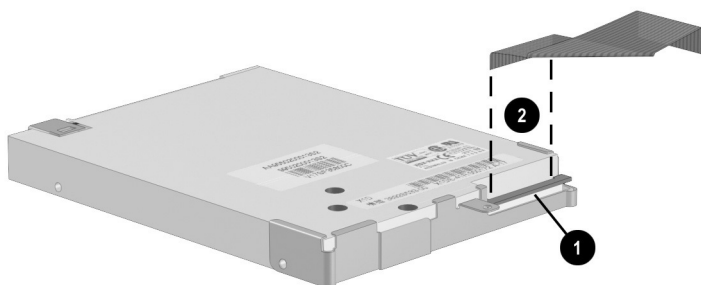

Figure 5-38. Removing the Diskette Drive Cable

Reverse the above procedure to install the diskette drive.

5.16 Charger Board

Charger Board Spare Part Number Information

Charger board

254109-001

1. Prepare the computer for disassembly (Section 5.3) and remove the following components:
 - a. Optical drive (Section 5.7)
 - b. LED cover (Section 5.8)
 - c. Keyboard (Section 5.9)
 - d. Display (Section 5.10)
 - e. Heat spreader (Section 5.11)
 - f. Top cover (Section 5.14)
 - g. Diskette drive (Section 5.15)

2. Remove the silver TM2.0 × 5.0 screw ❶ that secures the charger board to the system board (Figure 5-39).
3. Lift up on the back edge of the charger board ❷ to disconnect it from the system board.

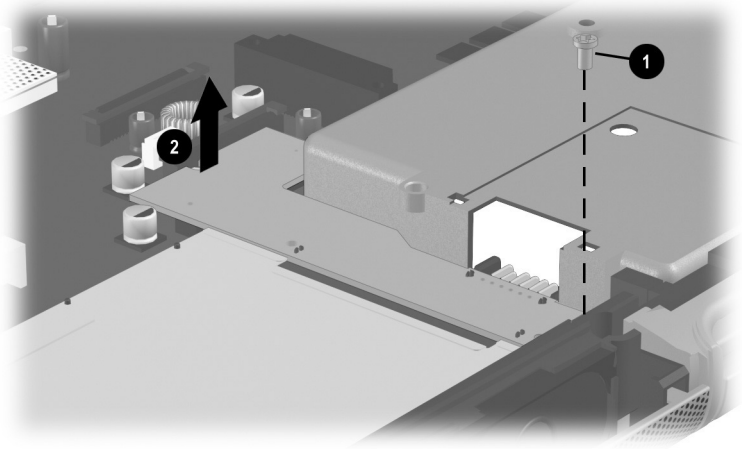

Figure 5-39. Disconnecting the Charger Board

4. Swing the right side of the charger board up and to the left ❶ until the hard drive connector clears the system board (Figure 5-40).
5. Remove the charger board ❷.

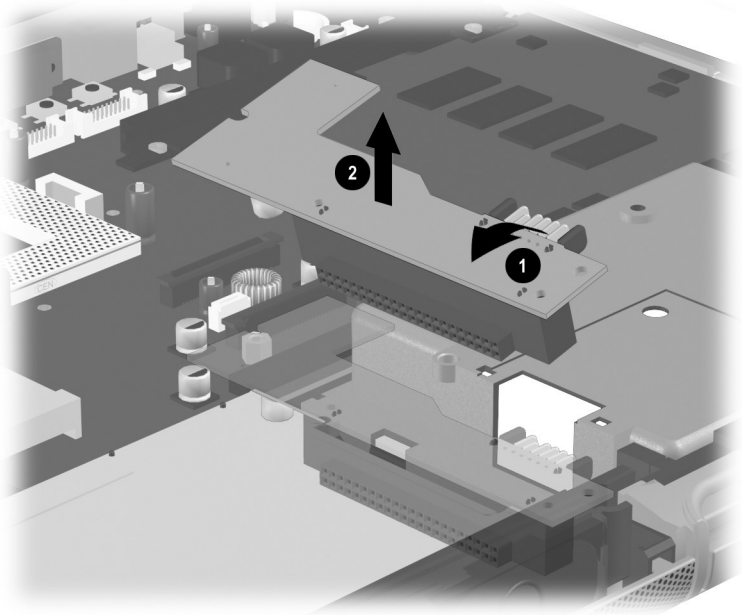

Figure 5-40. Removing the Charger Board

Reverse the above procedure to install the charger board.

5.17 Left Side Panel



The left side panel is included in the Plastics and Hardware Kit (spare part number 254121-001).

1. Prepare the computer for disassembly (Section 5.3) and remove the following components:
 - a. Optical drive (Section 5.7)
 - b. LED cover (Section 5.8)
 - c. Keyboard (Section 5.9)
 - d. Display (Section 5.10)
 - e. Heat spreader (Section 5.11)
 - f. Top cover (Section 5.14)
 - g. Diskette drive (Section 5.15)
2. Remove the following fasteners (Figure 5-41):
 - a. Three silver TM2.0 × 5.0 screws ❶
 - b. One silver HM5.0 × 13.0 standoff ❷
3. Slide the left side panel to the left to remove it from the base enclosure ❸.

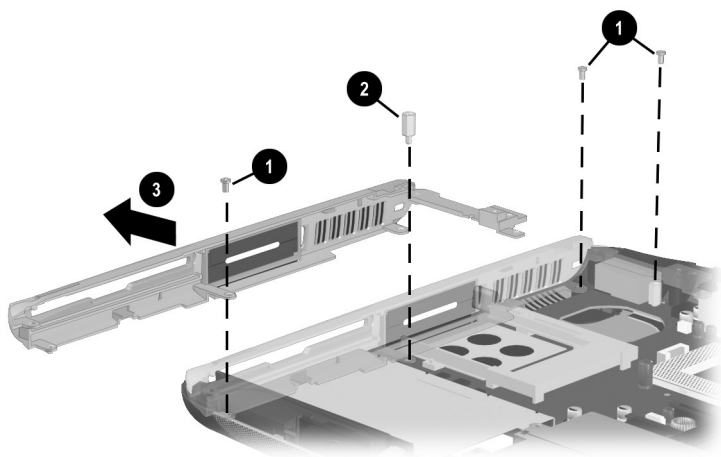

Figure 5-41. Removing the Left Side Panel

Reverse the above procedure to install the left side panel.

5.18 Right Side Panel



The right side panel is included in the Plastics and Hardware Kit (spare part number 254121-001).

1. Prepare the computer for disassembly (Section 5.3) and remove the following components:
 - a. Optical drive (Section 5.7)
 - b. LED cover (Section 5.8)
 - c. Keyboard (Section 5.9)
 - d. Display (Section 5.10)
 - e. Heat spreader (Section 5.11)
 - f. Top cover (Section 5.14)

2. Remove the three silver TM2.0 × 5.0 screws ❶ that secure the right side panel to the base enclosure (Figure 5-42).
3. Lift the slot ❷ on the alignment arm on the bezel off of the circular slot ❸ on the base enclosure.
4. Slide the right side panel to the right to remove it from the base enclosure ❹.

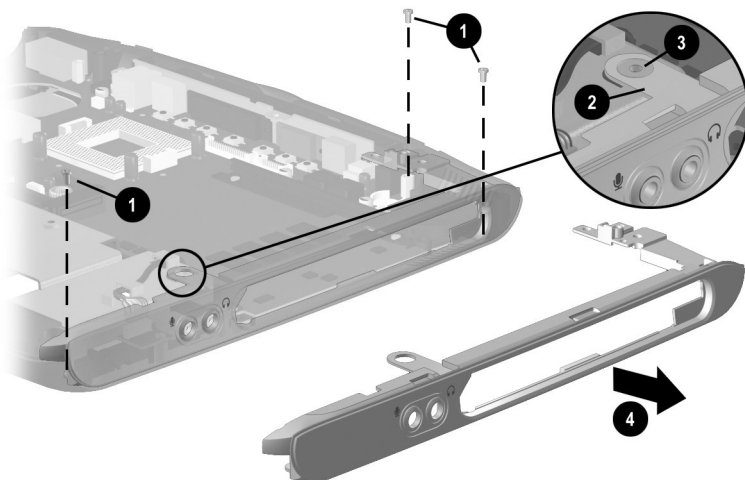

Figure 5-42. Removing the Right Side Panel

Reverse the above procedure to install the right side panel.

5.19 Speaker Assembly

Speaker Assembly Spare Part Number Information

Speaker assembly

254118-001

1. Prepare the computer for disassembly (Section 5.3) and remove the following components:
 - a. Optical drive (Section 5.7)
 - b. LED cover (Section 5.8)
 - c. Keyboard (Section 5.9)
 - d. Display (Section 5.10)
 - e. Heat spreader (Section 5.11)
 - f. Top cover (Section 5.14)
 - g. Diskette drive (Section 5.15)
 - h. Left side panel(Section 5.17)
 - i. Right side panel (Section 5.18)

2. Disconnect the speaker cable ❶ from the system board (Figure 5-43).
3. Lift the speaker assembly straight up and remove it ❷.

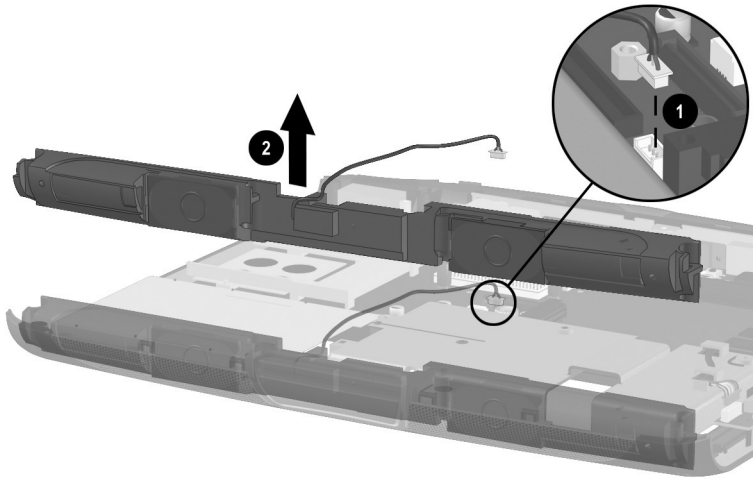

Figure 5-43. Removing the Speaker Assembly

Reverse the above procedure to install the speaker assembly.

5.20 Audio Board

Audio Board Spare Part Number Information

Audio board

254125-001

1. Prepare the computer for disassembly (Section 5.3) and remove the following components:
 - a. Optical drive (Section 5.7)
 - b. LED cover (Section 5.8)
 - c. Keyboard (Section 5.9)
 - d. Display (Section 5.10)
 - e. Heat spreader (Section 5.11)
 - f. Top cover (Section 5.14)
 - g. Diskette drive (Section 5.15)
 - h. Left side panel (Section 5.17)
 - i. Right side panel (Section 5.18)

2. Disconnect the audio cable ❶ from the audio board (Figure 5-44).
3. Remove the two silver TM2.0 × 5.0 screws ❷ that secure the audio board to the base enclosure.
4. Remove the audio board ❸.

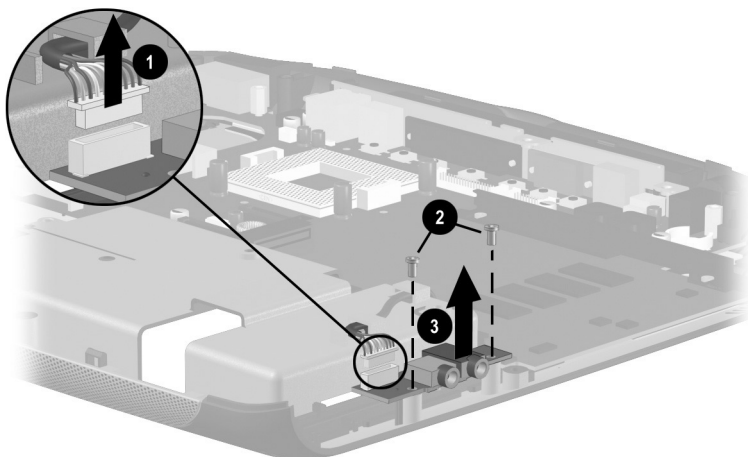

Figure 5-44. Removing the Audio Board

Reverse the above procedure to install the audio board.

5.21 Fan

Fan Spare Part Number Information

Fan

254123-001

1. Prepare the computer for disassembly (Section 5.3) and remove the following components:
 - a. Optical drive (Section 5.7)
 - b. LED cover (Section 5.8)
 - c. Keyboard (Section 5.9)
 - d. Display (Section 5.10)
 - e. Heat spreader (Section 5.11)
 - f. Top cover (Section 5.14)
 - g. Diskette drive (Section 5.15)
 - h. Right side panel (Section 5.18)

2. Disconnect the fan cable ❶ from the system board (Figure 5-45).
3. Remove the two silver TM2.0 × 5.0 screws ❷ that secure the fan to the system board.
4. Remove the fan ❸.

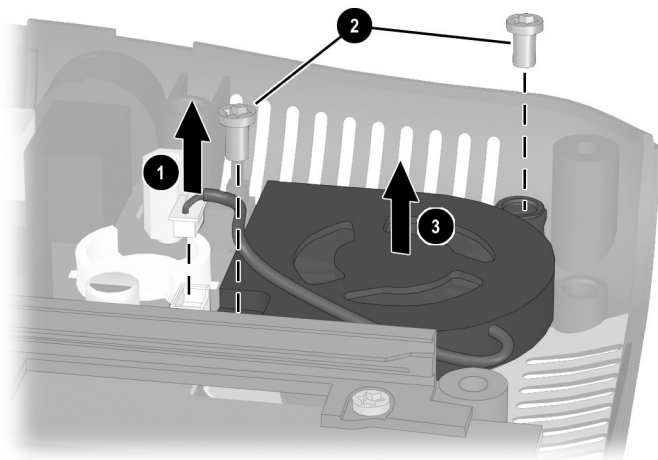

Figure 5-45. Removing the Fan

Reverse the above procedure to install the fan.

5.22 System Board

System Boards Spare Part Number Information

System boards

includes 256 MB SDRAM	263723-001
includes 128 MB SDRAM	254103-001



When replacing the system board, ensure that the following components are removed from the old system board and installed on the new system board:

- Memory expansion boards (Section 5.5)
 - Mini PCI communications board (Section 5.6)
 - Processor (Section 5.12)
 - Disk cell RTC battery (Section 5.13)
-

1. Prepare the computer for disassembly (Section 5.3) and remove the following components:
 - a. Optical drive (Section 5.7)
 - b. LED cover (Section 5.8)
 - c. Keyboard (Section 5.9)
 - d. Display (Section 5.10)
 - e. Heat spreader (Section 5.11)

- f. Top cover (Section 5.14)
 - g. Diskette drive (Section 5.15)
 - h. Charger board (Section 5.16)
 - i. Left side panel (Section 5.17)
 - j. Right side panel (Section 5.18)
 - k. Fan (Section 5.21)
2. Disconnect the audio cable ❶ from the audio board and remove the cable from the clips ❷ in the base enclosure (Figure 5-46).

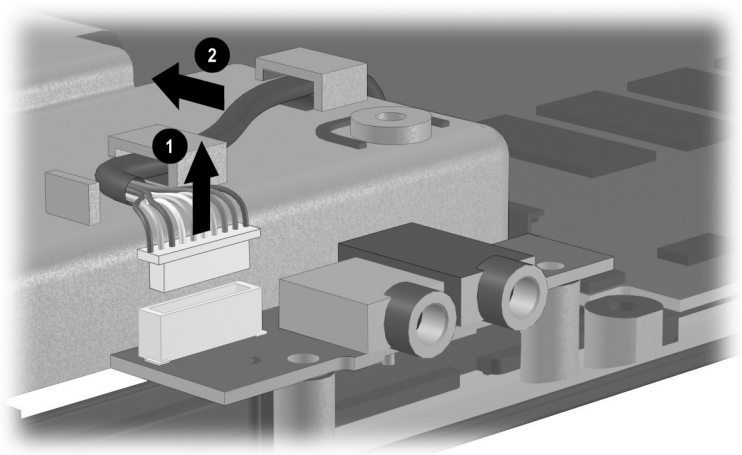

Figure 5-46. Disconnecting the Audio Cable

3. Remove the following components (Figure 5-47):
 - a. Four silver TM2.0 × 5.0 screws ❶ that secure the optical drive front and rear alignment rails
 - b. Optical drive front ❷ and rear ❸ alignment rails
 - c. Two silver HM5.0 × 17.5 standoffs ❹
 - d. One silver HM5.0 × 9.0 standoff ❺
 - e. One silver TM2.0 × 5.0 screw ❻ with bracket ❼

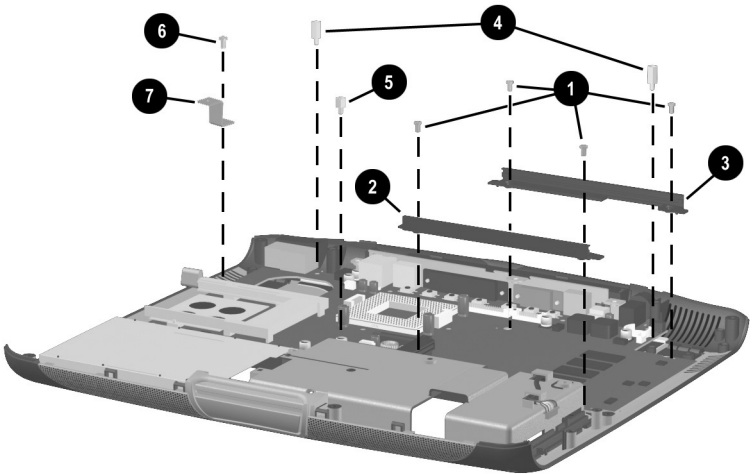

Figure 5-47. Removing the System Board Fasteners

4. Position the computer so the rear panel faces forward.

5. Open the connector cover ❶ to reveal the rear panel connectors (Figure 5-48).
6. Remove the four silver HM5.0 × 10.5 screwlocks ❷ on each side of the parallel and serial connectors.

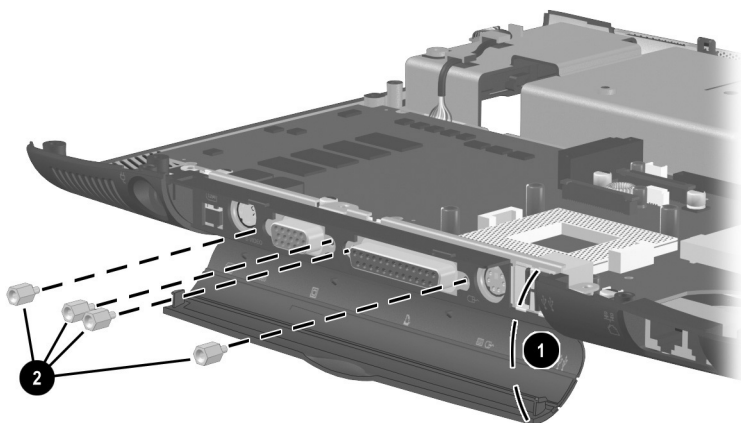

Figure 5-48. Removing the System Board Fasteners (continued)

7. Position the computer so the front faces forward.

8. Use the optical drive connector ❶ to lift the front of the system board ❷ until it clears the base enclosure (Figure 5-49).
9. Slide the system board forward ❸ and remove it from the base enclosure.

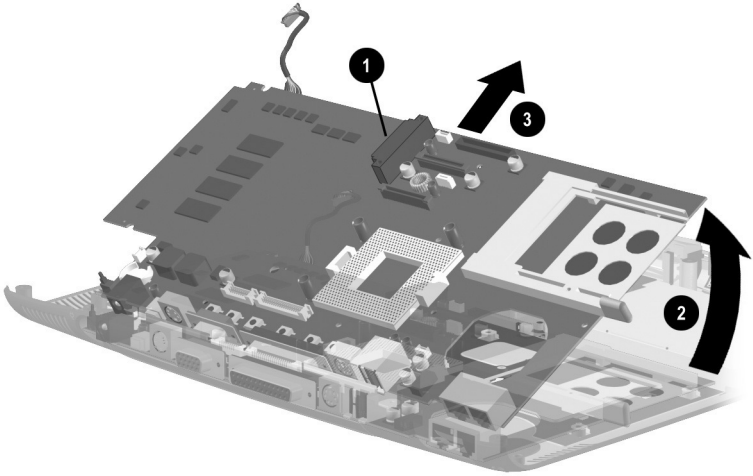

Figure 5-49. Removing the System Board

10. If necessary, disconnect the audio board cable from the system board (Figure 5-50).



The audio cable is included in the Cable Kit (spare part number 254120-001).

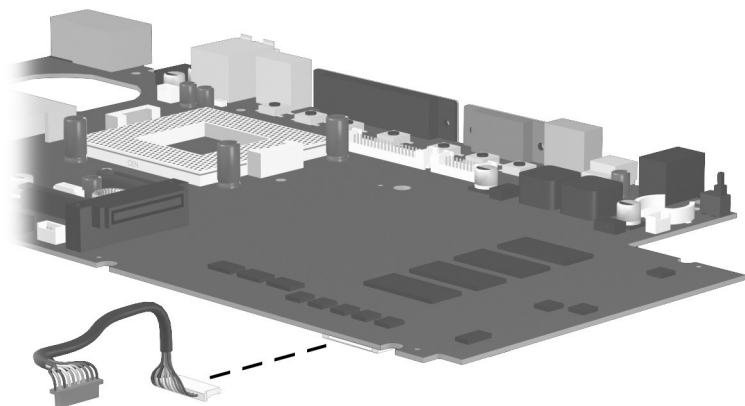

Figure 5-50. Removing the Audio Board Cable

Reverse the above procedure to install the system board.

6

Specifications

This chapter provides physical and performance specifications.

**Table 6-1
Computer**

Dimensions		
Height	12.4 in	31.5 cm
Width	10.6 in	26.9 cm
Depth	1.64 in	4.2 cm
Weight (depending on configuration and components)	6.63 lbs	3.0 kg
Stand-alone power requirements		
Nominal operating voltage	14.8 VDC	
Temperature		
Operating	50° to 90° F	10° to 35° C
Nonoperating	-4° to 140° F	-20° to 60° C
Relative humidity (noncondensing)		
Operating	10% to 90%	
Nonoperating	5% to 95%, 101.6° F (38.7° C) maximum wet bulb temperature	
Altitude (unpressurized)		
Operating	0 to 10,000 ft	0 to 3,048 m
Nonoperating	0 to 30,000 ft	0 to 9,144 m

Table 6-1
Computer (*Continued*)

Shock

Operating	10 G, 11 ms, half-sine
Nonoperating	60 G, 11 ms, half-sine

Vibration

Operating	0.5 G zero-to-peak, 10 to 500 Hz, at 0.5 oct/min sweep rate
Nonoperating	1.0 G zero-to-peak, 10 to 500 Hz, at 0.5 oct/min sweep rate



Applicable product safety standards specify thermal limits for plastic surfaces. The computer operates well within this range of temperatures.

Table 6-2
14.1-inch XGA, TFT Display

Dimensions		
Height	8.97 in	22.8 cm
Depth	11.76 in	29.9 cm
Diagonal	14.1 in	35.81 cm
Number of colors	256K	
Contrast ratio	150:1	
Brightness	120+ nit	
Pixel resolution		
Pitch	0.279 × 0.279 mm	
Format	1024 × 768	
Configuration	RGB vertical stripe	
Backlight	Cold cathode fluorescent, 1 tube	
Character display	80 × 25	
Refresh	60 Hz	
Total power consumption	4.75 W	

Table 6-3
13.3-inch XGA, TFT Display

Dimensions

Height	7.98 in	20.28 mm
Depth	10.64 in	27.03 mm
Width	13.30 in	33.79 mm

Number of colors Up to 16.8 million

Contrast ratio 150:1

Brightness 120 nits minimum, 150 nits typical

Pixel resolution

Pitch	0.264 × 0.264 mm
Format	1024 × 768
Configuration	RGB stripe

Backlight Edge lit, bottom

Character display 80 × 25

Refresh 60 Hz

Total power consumption 4.0 W

**Table 6-3
Hard Drives**

	30 GB	20 GB	15 GB	10 GB
User capacity per drive¹	30.0 GB	20.0 GB	15.0 GB	10.0 GB
Drive height (with drive frame)	9.5 mm	9.5 mm	9.5 mm	9.5 mm
Drive width (with drive frame)	70 mm	70 mm	70 mm	70 mm
Interface type	ATA-5	ATA-5	ATA-4	ATA-4
Seek times (typical read, including setting)				
Single track	2.5 ms	2.5 ms	2.5 ms	2.5 ms
Average	12.0 ms	12.0 ms	12.0 ms	12.0 ms
Full stroke	23.0 ms	23.0 ms	24.0 ms	23.0 ms
User addressable sectors³	58,605,120	39,070,080	23,579,136	19,640,880
Logical configuration				
Cylinders	22,784	16,283	16,683	16,283
Heads	16	16	16	16
Sectors per track	63	63	63	63

¹1 GB = 1,000,000,000 bytes.

²System capability may differ.

³Actual drive specifications may differ slightly.

Certain restrictions and exclusions apply. Consult the Compaq Customer Support Center for details.

**Table 6-3
Hard Drives (Continued)**

	30 GB	20 GB	15 GB	10 GB
Physical configuration				
Cylinders ³	22,784	22,784	25,800	22,784
Heads	6	4	2	4
Sectors per track ³	293 to 560	293 to 560	398 to 731	293 to 560
Bytes per sector	512	512	512	512
Buffer size³	2 MB	2 MB	512 KB	512 KB
Disk rotational speed	4200 rpm	4200 rpm	4200 rpm	4200 rpm
Transfer rate				
Interface max (MB/s) ²	66.6	66.6	100	66.6
Media (Mb/s) ³	109 to 203	109 to 203	155 to 256	109 to 203

¹1 GB = 1,000,000,000 bytes.

²System capability may differ.

³Actual drive specifications may differ slightly.

Certain restrictions and exclusions apply. Consult the Compaq Customer Support Center for details.

Table 6-4
Diskette Drive

Diskette size	3.5 inch
Light	On system
Height	0.5 in (12.7 mm)
Bytes per sector	512
Sectors per track	
High density	18 (1.44 MB)
Low density	9
Tracks per side	
High density	80
Low density	80
Read/write heads	2
Average seek times	
Track-to-track (high/low)	3 to 6 ms
Average (high/low)	95 to 174 ms
Settling time	15 ms
Latency average	100 ms

**Table 6-5
CD-ROM Drive**

Applicable disk	CD-ROM (Mode 1, 2, and 3) CD-XA ready (Mode 2, Form 1 and 2) CD-I ready (Mode 2, Form 1 and 2) CD-R (read only) CD Plus Photo CD (single/multisession) CD-Extra Video CD CD-WO (fixed packets only) CD-Bridge	
Center hole diameter	.59 in	1.5 cm
Disk diameter	12 cm, 8 cm	
Disk thickness	.047 in	1.2 mm
Track pitch	1.6 μ m	
Access time		
Random	< 150 ms	
Full stroke	< 300 ms	
Cache buffer	128 KB	
Data transfer rate		
Sustained, 16X	150 KB/s at 1X	
Variable	1500 to 3600 KB/s (10X to 24X)	
Normal PIO Mode 4 (single burst)	16.66 KB/s	
Startup time	< 8 seconds	
Stop time	< 4 seconds	

Table 6-6
DVD-ROM Drive

Applicable disk	DVD-5, DVD-9, DVD-10 CD-ROM (Mode 1 and 2) CD Digital Audio CD-XA ready (Mode 2, Form 1 and 2) CD-I ready (Mode 2, Form 1 and 2) CD-R (read only) CD Plus Photo CD (single/multisession) CD-Bridge	
Center hole diameter	.59 in	1.5 cm
Disk diameter		12 cm, 8 cm
Disk thickness	.047 in	1.2 mm
Track pitch	.74 μ m	
Access time		
Random	< 150 ms	
Full stroke	< 225 ms	
Audio output level	Line-out, 0.7 Vrms	
Cache buffer	512 KB	
Data transfer rate		
Max 24X CD	3600 KB/s (150 KB/s at 1X CD rate)	
Max 8X DVD	10,800 KB/s (1352 KB/s at 1X DVD rate)	
Normal IO Mode 4 (single burst)	16.6 MB/s	
Startup time	< 12 seconds	
Stop time	< 3 seconds	

Table 6-7
CD-RW Drive

Center hole diameter	.59 in	.39 cm
Disk diameter		12 cm, 8 cm
Disk thickness	.47 in	.12 cm
Track pitch	.74 μ m	
Access time		
Random	< 150 ms	
Full stroke	< 225 ms	
Audio output level	Line-out, 0.7 Vrms	
Cache buffer	128 KB	
Data transfer rate		
Sustained, 16X	150 KB/s	
Sustained, 4X CD-RW	5,520 KB/s	
Normal PIO Mode 4 (single burst)	16.6 MB/s	
Startup time	< 15 seconds	
Stop time	< 6 seconds	

Table 6-8
External AC Adapter

Weight	.45 lb	.21 kg
Power supply (input)		
Operating voltage	100 to 240 VAC RMS nominal	
Operating current	1.5 A RMS	
Operating frequency range	50 to 60 Hz AC nominal	
Maximum transient	4/50 kV	

Table 6-9
8-cell, Li ion Battery Pack

Dimensions		
Height	0.82 in	21 mm
Width	5.67 in	144 mm
Depth	3.03 in	77 mm
Weight	.94 lb	.43 kg
Energy		
4.0 Amp hour		
Voltage	14.4 V	
Amp-hour capacity	4.0 Ah	
Watt-hour capacity	57.6 Wh	
3.6 Amp hour		
Voltage	14.4 V	
Amp-hour capacity	3.6 Ah	
Watt-hour capacity	51.8 Wh	
Temperature		
Operating	50 to 104° F	10 to 40° C
Nonoperating	-4 to 104° F	-20 to 60° C

Table 6-10
System DMA

Hardware DMA	System Function
DMA0	Available for audio
DMA1	Entertainment audio (default; alternate = DMA0, DMA3, none)
DMA2	Diskette drive
DMA3	ECP parallel port LPT1 (default; alternate = DMA0, none)
DMA4	DMA controller cascading (not available)
DMA5	Available for PC Card
DMA6	Not assigned
DMA7	Not assigned

 PC Card controller can use DMA 1, 2, or 5.

**Table 6-11
System Interrupts**

Hardware IRQ	System Function
IRQ0	System timer
IRQ1	Keyboard controller
IRQ2	Cascaded
IRQ3	COM2
IRQ4	COM1
IRQ5	Audio (default)*
IRQ6	Diskette drive
IRQ7	Parallel port
IRQ8	Real time clock (RTC)
IRQ9	Infrared
IRQ10	System use
IRQ11	System use
IRQ12	Internal point stick or external mouse
IRQ13	Coprocessor (not available to any peripheral)
IRQ14	IDE interface (hard drive and optical drive)
IRQ15	System use



PC Cards may assert IRQ3, IRQ4, IRQ5, IRQ7, IRQ9, IRQ10, IRQ11, or IRQ15. Either the infrared or the serial port may assert IRQ3 or IRQ 4.

*Default configuration; audio possible configurations are IRQ5, IRQ7, IRQ9, IRQ10, or none.

Table 6-12
System I/O Addresses

I/O Address (hex)	System Function (shipping configuration)
000 - 00F	DMA controller no. 1
010 - 01F	Unused
020 - 021	Interrupt controller no. 1
022 - 024	Opti chipset configuration registers
025 - 03F	Unused
02E - 02F	87334 "Super IO" configuration for CPU
040 - 05F	Counter/timer registers
044 - 05F	Unused
060	Keyboard controller
061	Port B
062 - 063	Unused
064	Keyboard controller
065 - 06F	Unused
070 - 071	NMI enable/real time clock
072 - 07F	Unused
080 - 08F	DMA page registers
090 - 091	Unused
092	Port A
093 - 09F	Unused
0A0 - 0A1	Interrupt controller no. 2

Table 6-12
System I/O Addresses (*Continued*)

I/O Address (hex)	System Function (shipping configuration)
0A2 - 0BF	Unused
0C0 - 0DF	DMA controller no. 2
0E0 - 0EF	Unused
0F0 - 0F1	Coprocessor busy clear/reset
0F2 - 0FF	Unused
100 - 16F	Unused
170 - 177	Secondary fixed disk controller
178 - 1EF	Unused
1F0 - 1F7	Primary fixed disk controller
1F8 - 200	Unused
201	Joystick (decoded in ESS1688)
202 - 21F	Unused
220 - 22F	Entertainment audio
230 - 26D	Unused
26E - 26	Unused
278 - 27F	Unused
280 - 2AB	Unused
2A0 - 2A7	Unused
2A8 - 2E7	Unused
2E8 - 2EF	Reserved serial port

Table 6-12
System I/O Addresses (*Continued*)

I/O Address (hex)	System Function (shipping configuration)
2F0 - 2F7	Unused
2F8 - 2FF	Infrared port
300 - 31F	Unused
320 - 36F	Unused
370 - 377	Secondary diskette drive controller
378 - 37F	Parallel port (LPT1/default)
380 - 387	Unused
388 - 38B	FM synthesizer - OPL3
38C - 3AF	Unused
3B0 - 3BB	VGA
3BC - 3BF	Reserved (parallel port/no EPP support)
3C0 - 3DF	VGA
3E0 - 3E1	PC Card controller in CPU
3E2 - 3E3	Unused
3E8 - 3EF	Internal modem
3F0 - 3F7	"A" diskette controller
3F8 - 3FF	Serial port (COM1/default)
CF8 - CFB	PCI configuration index register (PCIDIVO-1)
CFC - CFF	PCI configuration data register (PCIDIVO-1)

Table 6-13
System Memory Map

Size	Memory Address	System Function
640 KB	00000000 - 0009FFFF	Base memory
128 KB	000A0000 - 000BFFFF	Video memory
48 KB	000C0000 - 000CBFFF	Video BIOS
160 KB	000C8000 - 000E7FFF	Unused
64 KB	000E8000 - 000FFFFFFF	System BIOS
15 MB	00100000 - 00FFFFFFF	Extended memory
58 MB	01000000 - 047FFFFFFF	Super extended memory
58 MB	04800000 - 07FFFFFFF	Unused
2 MB	08000000 - 080FFFFFFF	Video memory (direct access)
4 GB	08200000 - FFFEFFFFFF	Unused
64 KB	FFFF0000 - FFFFFFFF	System BIOS

A

Connector Pin Assignments

Table A-1
RJ-45 Network Interface

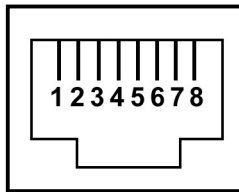

Pin	Signal	Pin	Signal
1	Transmit +	5	Unused
2	Transmit -	6	Receive -
3	Receive +	7	Unused
4	Unused	8	Unused

Table A-2
RJ-11 Modem

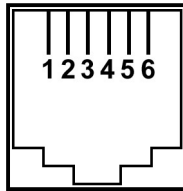

Pin	Signal	Pin	Signal
1	Unused	4	Unused
2	Tip	5	Unused
3	Ring	6	Unused

Table A-3
Universal Serial Bus

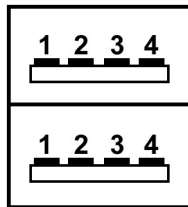

Pin	Signal	Pin	Signal
1	+5 VDC	3	Data +
2	Data -	4	Ground

Table A-4
S-Video

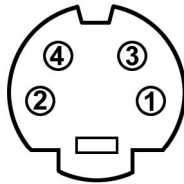

Pin	Signal	Pin	Signal
1	Ground (Y)	3	Y-Luminance (Intensity)
2	Ground (C)	4	C-Chrominance (Color)

**Table A-5
Parallel**

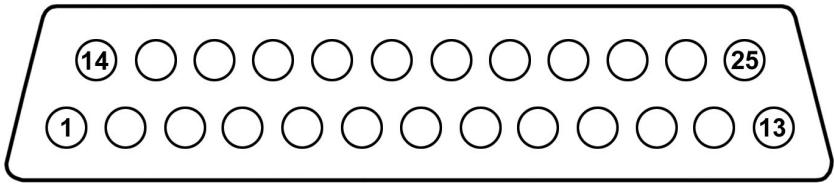

Pin	Signal	Pin	Signal
1	Strobe*	10	Acknowledge*
2	Data bit 0	11	Busy
3	Data bit 1	12	Paper out
4	Data bit 2	13	Select
5	Data bit 3	14	Auto line feed*
6	Data bit 4	15	Error*
7	Data bit 5	16	Initialize printer*
8	Data bit 6	17	Select in*
9	Data bit 7	18-25	Signal ground

*Signal is active low.

Table A-6
External Monitor

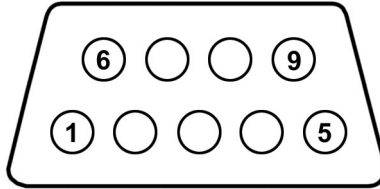

Pin	Signal	Pin	Signal
1	Red analog	9	+5 VDC
2	Green analog	10	Ground
3	Blue analog	11	Monitor detect
4	Not connected	12	DDC 2B data
5	Ground	13	Horizontal sync
6	Ground analog	14	Vertical sync
7	Ground analog	15	DDC 2B clock
8	Ground analog		

Table A-7
Stereo Speaker/Headphone

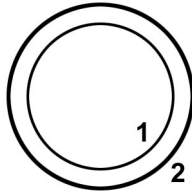

Pin	Signal	Pin	Signal
1	Audio out	2	Ground

Table A-8
Microphone

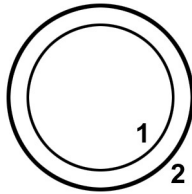

Pin	Signal	Pin	Signal
1	Audio in	2	Ground

Table A-9
External Keyboard/Mouse

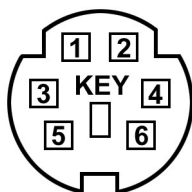

Pin	Signal	Pin	Signal
1	Keyboard/mouse DATA	4	+5 VDC
2	Keyboard/mouse DATA	5	Keyboard/mouse CLK
3	Ground	6	Keyboard/mouse CLK

Power Cord Set Requirements

3-Conductor Power Cord Set

The computer's wide range input feature permits it to operate from any line voltage from 100 to 120 or 220 to 240 volts AC.

The power cord set received with the computer meets the requirements for use in the country where the equipment is purchased.

Power cord sets for use in other countries must meet the requirements of the country where the computer is used. For more information on power cord set requirements, contact a Compaq authorized reseller or service provider.

General Requirements

The requirements listed below are applicable to all countries:

- The length of the power cord set must be at least 5.00 feet (1.5 m) and a maximum of 6.50 feet (2.0 m).
- All power cord sets must be approved by an acceptable accredited agency responsible for evaluation in the country where the power cord set will be used.
- The power cord set must have a minimum current capacity of 10 amps and a nominal voltage rating of 125 or 250 volts AC, as required by each country's power system.
- The appliance coupler must meet the mechanical configuration of an EN 60 320/IEC 320 Standard Sheet C13 connector, for mating with the appliance inlet on the back of the computer.

Country-Specific Requirements

3-Conductor Power Cord Set Requirements

Country	Accredited Agency	Applicable Note Number
Australia	EANSW	1
Austria	OVE	1
Belgium	CEBC	1
Canada	CSA	2
Denmark	DEMKO	1
Finland	FIMKO	1
France	UTE	1
Germany	VDE	1
Italy	IMQ	1
Japan	METI	3
The Netherlands	KEMA	1
Norway	NEMKO	1
Sweden	SEMKO	1
Switzerland	SEV	1
United Kingdom	BSI	1
United States	UL	2

Notes

1. The flexible cord must be <HAR> Type HO5VV-F, 3-conductor, 1.0 mm² conductor size. Power cord set fittings (appliance coupler and wall plug) must bear the certification mark of the agency responsible for evaluation in the country where it will be used.

2. The flexible cord must be Type SPT-3 or equivalent, No. 18 AWG, 3-conductor. The wall plug must be a two-pole grounding type with a NEMA 5-15P (15 A, 125 V) or NEMA 6-15P (15 A, 250 V) configuration.
3. The appliance coupler, flexible cord, and wall plug must bear a “T” mark and registration number in accordance with the Japanese Dentori Law. The flexible cord must be Type VCT or VCTF, 3-conductor, 1.00 mm² conductor size. The wall plug must be a two-pole grounding type with a Japanese Industrial Standard C8303 (7 A, 125 V) configuration.

C

Screw Listing

This appendix provides specification and reference information for the screws used in the computer. All screws listed in this appendix are available in the Miscellaneous Screw Kit, spare part number 254122-001.

Table C-1
Phillips M2.0 × 7.0 Screw

	Color	Qty	Length	Thread	Head Width
	black	1	7.0 mm	2.0 mm	4.0 mm

Where used:

One screw that secures the hard drive to the computer
(documented in Section 5.3, step 4b)

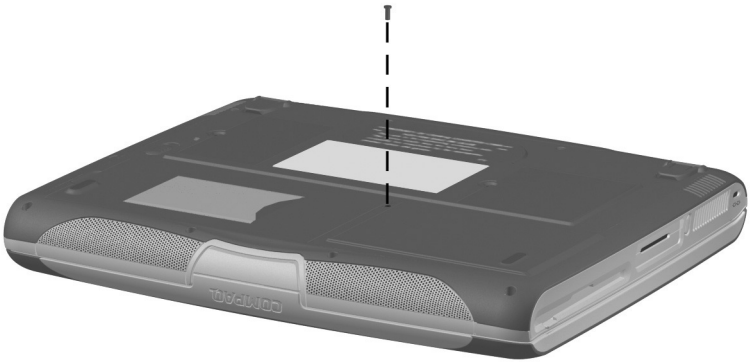



Figure C-1. Phillips M2.0 × 7.0 Screw Location

Table C-2
Phillips M2.5 × 3.5 Screw

	Color	Qty	Length	Thread	Head Width
	black	4	3.5 mm	2.5 mm	5.0 mm

Where used:

Four screws that secure the hard drive to the hard drive bracket
(documented in Section 5.3, step 5a)

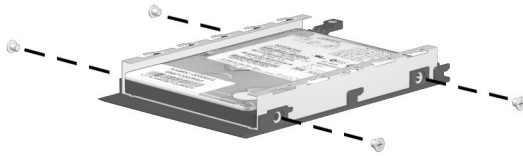



Figure C-2. Phillips M2.5 × 3.5 Screw Locations

Table C-3
Phillips M2.0 x 5.0 Screw

	Color	Qty	Length	Thread	Head Width
	black	2	5.0 mm	2.0 mm	4.5 mm

Where used:

- ❶ One screw that secures the memory expansion compartment cover to the base enclosure (documented in Section 5.4, step 3)
- ❷ One screw that secures the mini PCI compartment cover to the top cover (documented in Section 5.6, step 3)

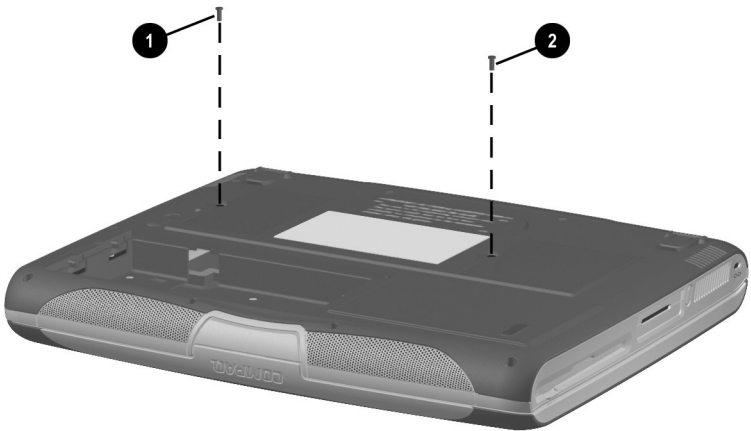



Figure C-3. Phillips M2.0 x 5.0 Screw Locations

Table C-4
Torx M2.0 x 7.5 Screw

	Color	Qty	Length	Thread	Head Width
	pewter	12	7.5 mm	2.0 mm	4.5 mm

Where used:

- ❶ Two screws that secure the LED cover to the base enclosure (documented in Section 5.7, step 3)
- ❷ Two screws that secure the optical drive to the base enclosure (documented in Section 5.9, step 5)
- ❸ Six screws that secure the top cover to the base enclosure (documented in Section 5.14, step 3)

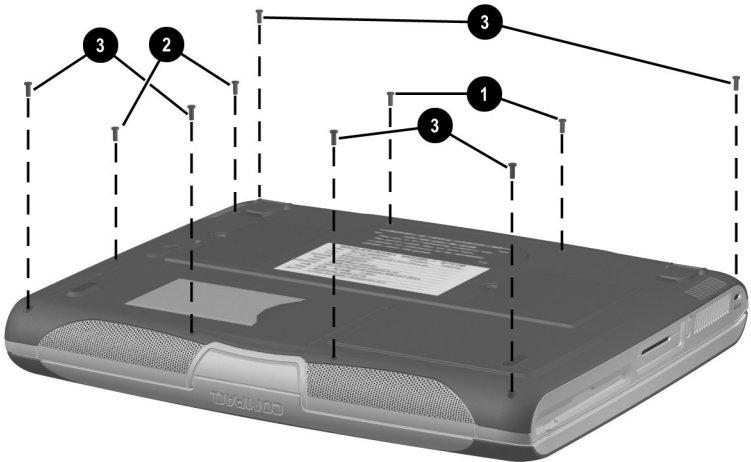



Figure C-4. Torx M2.0 x 7.5 Screw Locations

Table C-4
Torx M2.0 × 7.5 Screw (Continued)

	Color	Qty	Length	Thread	Head Width
	pewter	12	7.5 mm	2.0 mm	4.5 mm

Where used:

- ❶ One screw that secures the display ground cables to the base enclosure (documented in Section 5.10, step 9)
 - ❷ One screw that secures the top cover to the base enclosure (documented in Section 5.14, step 7)
-

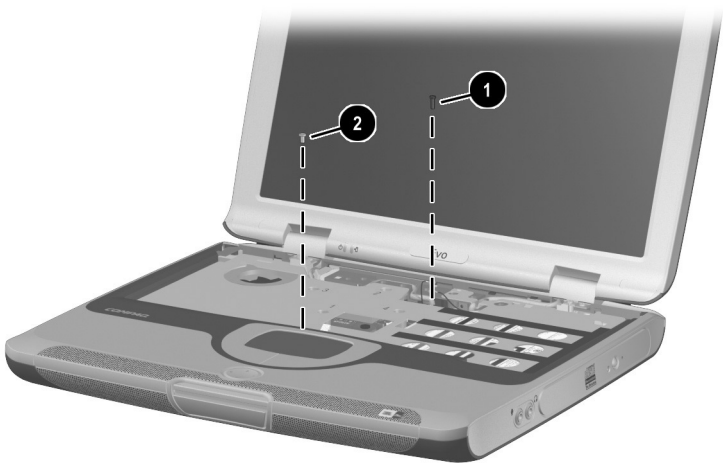

Figure C-5. Torx M2.0 × 7.5 Screw Locations (Continued)

Table C-5
Torx M2.0 x 5.0 Screw



Color	Qty	Length	Thread	Head Width
silver	27	5.0 mm	2.0 mm	4.5 mm

Where used:

- ❶ Two screws that secure the display hinge covers to the base enclosure (documented in Section 5.10, step 4)
- ❷ Three screws that secure the heat spreader to the base enclosure (documented in Section 5.11, step 2)
- ❸ Two screws that secure the top cover to the base enclosure (documented in Section 5.14, step 7)

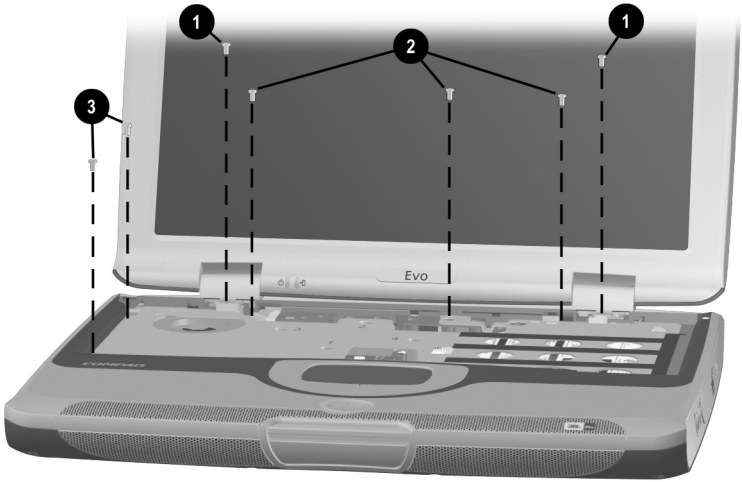



Figure C-6. Torx M2.0 x 5.0 Screw Locations

Table C-5
Torx M2.0 × 5.0 Screw (Continued)

	Color	Qty	Length	Thread	Head Width
	silver	27	5.0 mm	2.0 mm	4.5 mm

Where used:

Three screws that secure the top cover to the base enclosure in the battery bay (documented in Section 5.14, step 4)

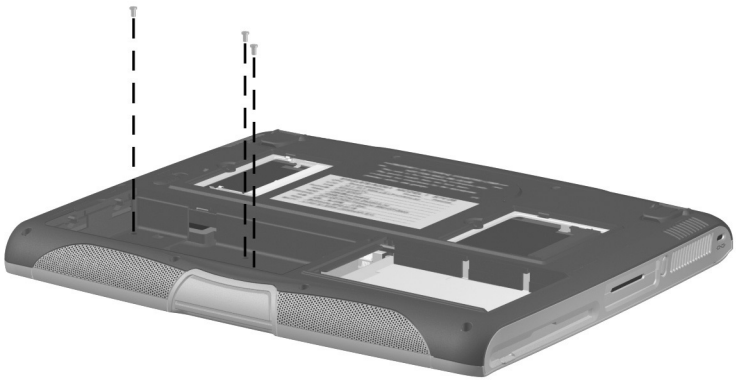



Figure C-7. Torx M2.0 × 5.0 Screw Locations (Continued)

Table C-5
Torx M2.0 × 5.0 Screw (Continued)

	Color	Qty	Length	Thread	Head Width
	silver	27	5.0 mm	2.0 mm	4.5 mm

Where used:

- ① One screw that secures the diskette drive to the base enclosure (documented in Section 5.15, step 3)
- ② One screw that secures the charger board to the base enclosure (documented in Section 5.16, step 2)

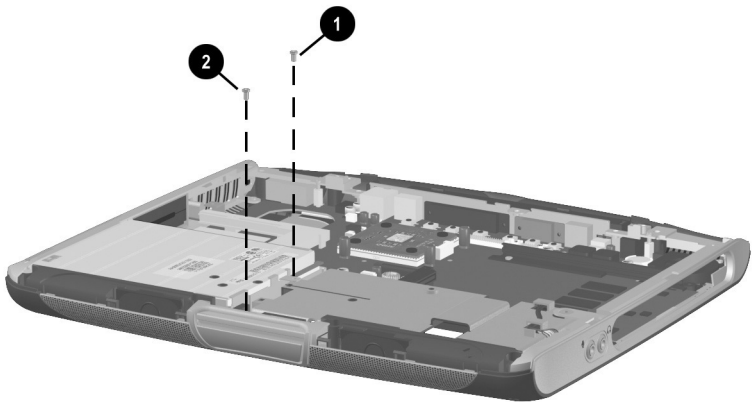



Figure C-8. Torx M2.0 × 5.0 Screw Locations (Continued)

Table C-5
Torx M2.0 × 5.0 Screw (Continued)

	Color	Qty	Length	Thread	Head Width
	silver	27	5.0 mm	2.0 mm	4.5 mm

Where used:

Three screws that secure the left side panel to the base enclosure (documented in Section 5.17, steps 2a and 2b)

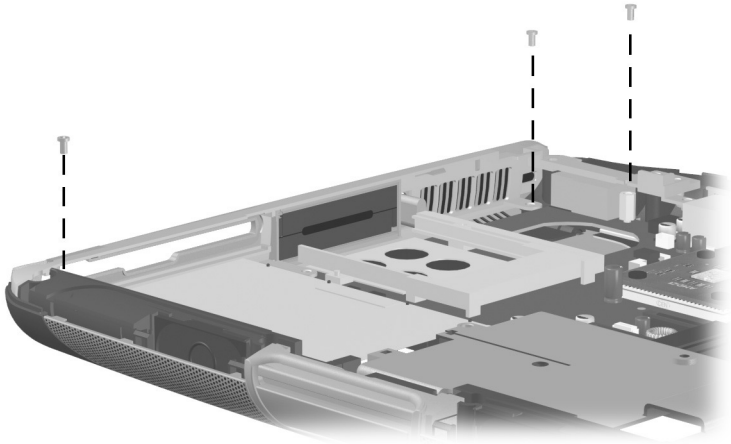



Figure C-9. Torx M2.0 × 5.0 Screw Locations (Continued)

Table C-5
Torx M2.0 × 5.0 Screw (Continued)

	Color	Qty	Length	Thread	Head Width
	silver	27	5.0 mm	2.0 mm	4.5 mm

Where used:

Three screws that secure the right side panel to the base enclosure (documented in Section 5.18, step 2)

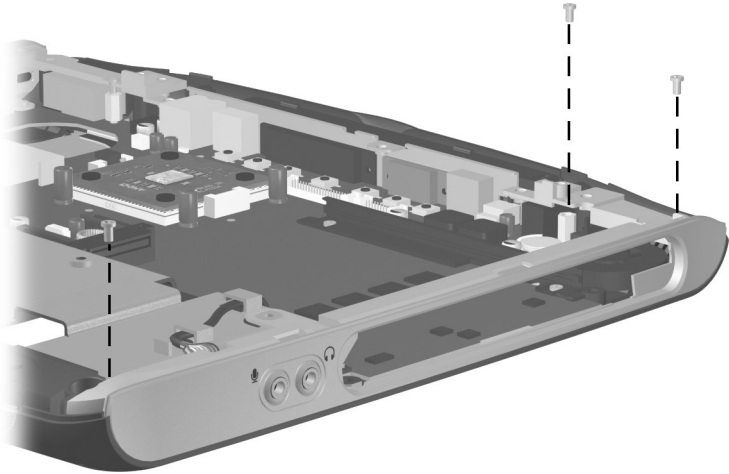



Figure C-10. Torx M2.0 × 5.0 Screw Locations (Continued)

Table C-5
Torx M2.0 x 5.0 Screw (Continued)

	Color	Qty	Length	Thread	Head Width
	silver	27	5.0 mm	2.0 mm	4.5 mm

Where used:

- ❶ Two screws that secure the audio board to the base enclosure (documented in Section 5.20, step 3)
- ❷ Two screws that secure the fan to the base enclosure (documented in Section 5.21, step 3)

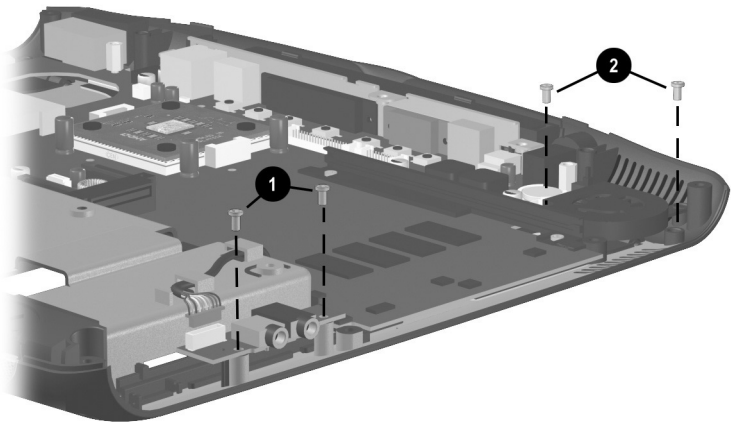



Figure C-11. Torx M2.0 x 5.0 Screw Locations (Continued)

Table C-5
Torx M2.0 × 5.0 Screw (Continued)

	Color	Qty	Length	Thread	Head Width
	silver	27	5.0 mm	2.0 mm	4.5 mm

Where used:

- ❶ Four screws that secure the optical drive front and rear alignment rails to the base enclosure (documented in Section 5.22, step 3a)
- ❷ One screw that secures the PC Card bracket and system board to the base enclosure (documented in Section 5.22, step 3e)

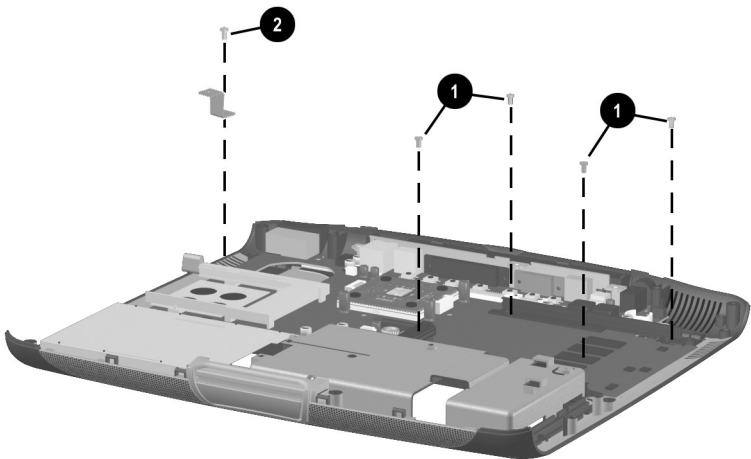

Figure C-12. Torx M2.0 × 5.0 Screw Locations (Continued)

Table C-6
Torx M2.0 x 8.0 Screw



	Color	Qty	Length	Thread	Head Width
	silver	4	8.0 mm	2.0 mm	4.5 mm

Where used:

Four screws that secure the display to the base enclosure
(documented in Section 5.10, step 12)

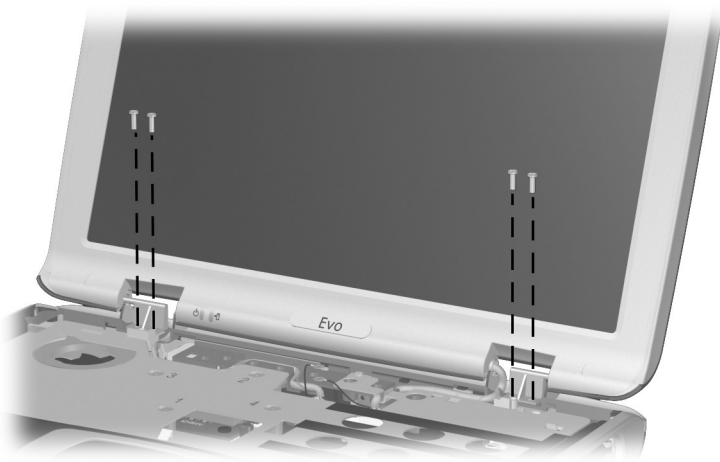

Figure C-13. Torx M2.0 x 8.0 Screw Locations

Table C-7
Torx M2.0 × 20.0 Screw



	Color	Qty	Length	Thread	Head Width
	silver	4	20.0 mm	2.0 mm	6.0 mm

Where used:

Four spring-loaded screws that secure the heat spreader to the base enclosure (documented in Section 5.11, step 3)

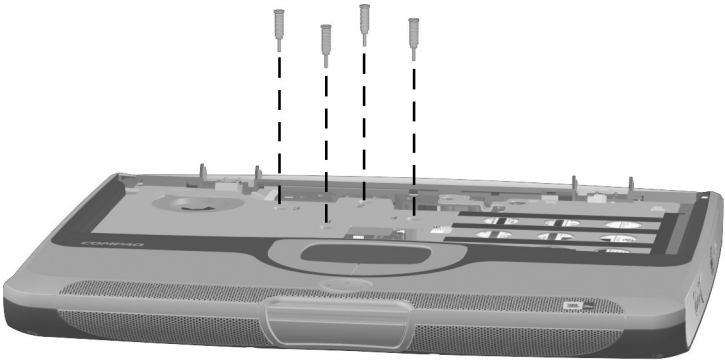



Figure C-14. Torx M2.0 × 20.0 Screw Locations

Table C-8
Hex M5.0 × 13.0 Standoff

	Color	Qty	Length	Thread	Head Width
	silver	1	13.0 mm	5.0 mm	n/a

Where used:

One standoff that secures the left side panel to the base enclosure (documented in Section 5.17, step 2c)

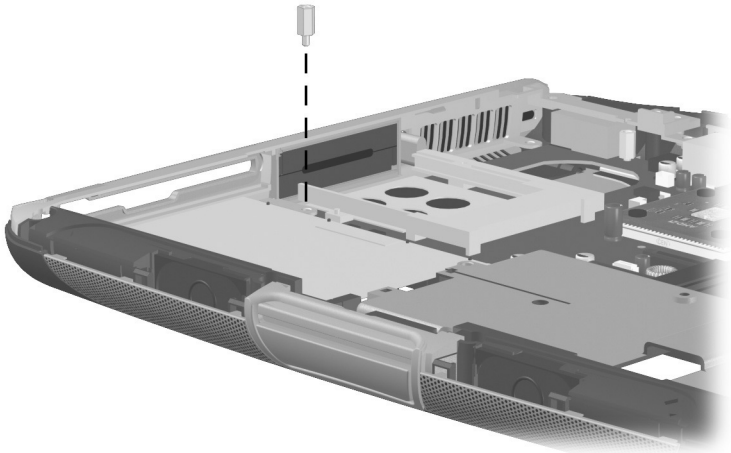
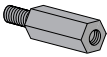

Figure C-15. Hex M5.0 × 13.0 Standoff Location

Table C-9
Hex M5.0 × 17.5 Standoff



	Color	Qty	Length	Thread	Head Width
	silver	2	17.5 mm	5.0 mm	n/a

Where used:

Two standoffs that secure the system board to the base enclosure (documented in Section 5.22, step 3c)

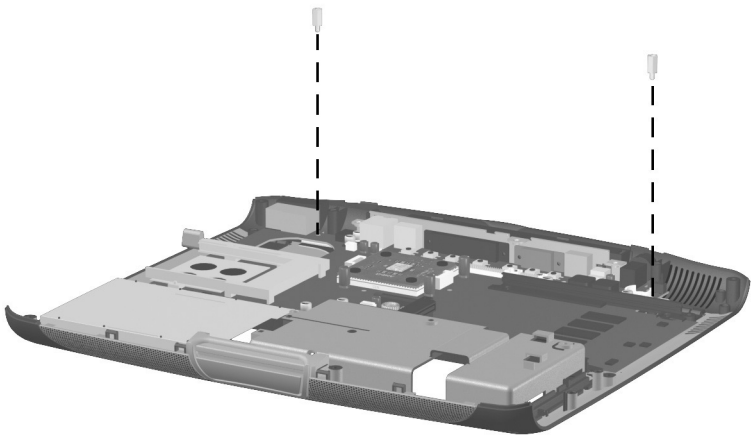

Figure C-16. Hex M5.0 × 17.5 Standoff Locations

Table C-10
Hex M5.0 × 9.0 Standoff



	Color	Qty	Length	Thread	Head Width
	silver	1	9.0 mm	5.0 mm	n/a

Where used:

One standoff that secures the system board to the base enclosure (documented in Section 5.22, step 3d)

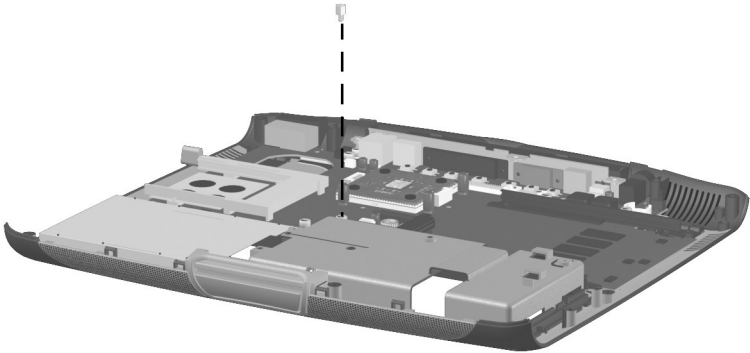

Figure C-17. Hex M5.0 × 9.0 Standoff Location

Table C-11
Hex M5.0 × 10.5 Standoff



	Color	Qty	Length	Thread	Head Width
	silver	4	10.5 mm	5.0 mm	n/a

Where used:

Four screwlocks that secure the system board to the base enclosure through the rear panel (documented in Section 5.22, step 6)

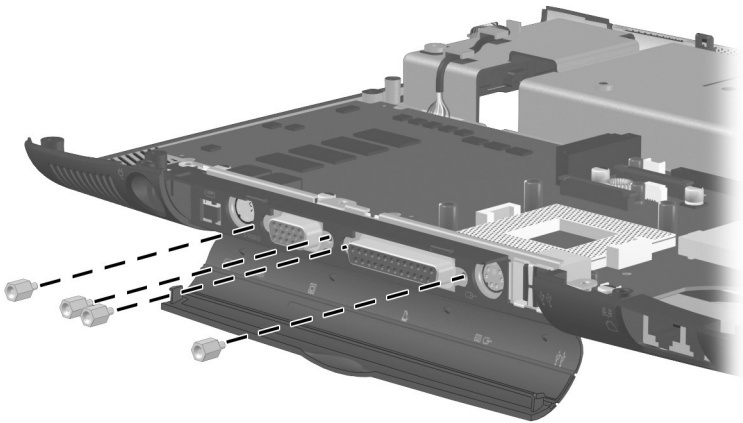

Figure C-18. Hex M5.0 × 10.5 Standoff Locations

Index

A

- AC adapter
 - spare part number 3–12
 - specifications 6–11
- audio board
 - illustrated 3–6
 - removal 5–54
 - spare part number 3–7, 5–54
- audio board cable
 - illustrated 3–9
 - removal 5–63
- audio troubleshooting 2–17

B

- base enclosure
 - illustrated 3–6
 - spare part number 3–7
- battery bay 1–21
- battery bracket
 - illustrated 3–2, 3–8
 - removal 5–7
- battery light 1–14, 1–19
- battery pack
 - illustrated 3–6
 - removal 5–5
 - spare part numbers 3–7
 - specifications 6–11
- battery release switch 1–21

- battery, real time clock (RTC)
 - illustrated 3–4
 - removal 5–36
 - spare part number 3–5, 5–36
- bottom components 1–20

C

- Cable Kit 3–5, 3–9
- cables, service considerations 4–2
- caps lock light 1–19
- CD-ROM drive
 - OS loading problems 2–16
 - specifications 6–8
- CD-RW drive, specifications 6–10
- charger board
 - illustrated 3–6
 - removal 5–46
 - spare part number 3–7, 5–46
- components
 - bottom 1–20
 - keyboard 1–16
 - left side 1–12
 - rear panel 1–14
 - right side 1–11
 - top 1–18
- computer specifications 6–1

- connector pin assignments
 - external monitor connector A-5
 - headphone jack A-6
 - microphone jack A-6
 - modem connector A-2
 - monitor connector A-5
 - network connector A-1
 - parallel connector A-4
 - RJ-11 jack A-2
 - RJ-45 jack A-1
 - speaker jack A-6
 - S-video A-3
 - USB connector A-2
- connectors, service
 - considerations 4-2
- cursor control keys 1-17

D

- DC power jack 1-15
- design overview 1-22
- digital audio button 1-19
- disassembly sequence chart 5-3
- diskette drive
 - illustrated 3-6, 3-9, 3-10
 - location 1-13
 - OS loading problems 2-15
 - removal 5-42
 - spare part number 3-7, 3-10, 5-42
 - specifications 6-7
- diskette drive cable, removal 5-45

- display
 - illustrated 3-2
 - removal 5-22
 - spare part numbers 3-3, 5-22
 - specifications 6-3, 6-4
- display lid switch 1-19
- display release latch 1-19
- DMA specifications 6-12
- docking station,
 - troubleshooting 2-10
- drive activity light 1-14, 1-18, 1-19
- drives, preventing damage 4-3
 - see also specific types of drives*
- DVD-ROM drive
 - OS loading problems 2-16
 - specifications 6-9

E

- Easy Access buttons 1-19
- EasyScroll button 1-19
- electrostatic discharge 4-4, 4-7
- embedded numeric keypad 1-17
- external keyboard connector
 - location 1-15
 - pin assignments A-7
- external monitor connector
 - location 1-15
 - pin assignments A-5
- external mouse connector
 - location 1-15
 - pin assignments A-7

F

- fan
 - illustrated 3–4
 - removal 5–56
 - spare part number 3–7, 5–56
- features 1–8
- feet 5–11
- Fn key 1–17
- function keys 1–17

G

- grounding equipment and methods 4–6

H

- hard drive
 - illustrated 3–6, 3–10
 - OS loading problems 2–12
 - removal 5–8
 - spare part numbers 3–7, 3–10
 - specifications 6–5
- hard drive bay 1–21
- hard drive bezel
 - illustrated 3–2, 3–8
 - removal 5–10
- hard drive retention screw 1–21
- headphone jack
 - location 1–11
 - pin assignments A–6
- heat spreader
 - illustrated 3–4

- removal 5–28
- spare part number 3–5, 5–28

- hinge cover
 - illustrated 3–2, 3–8
 - removal 5–23

I

- I/O address specifications 6–14
- illustrated parts catalog 3–1
- interrupt specifications 6–13

K

- keyboard
 - components 1–16
 - illustrated 3–2
 - removal 5–20
 - spare part numbers 3–3, 5–20
 - troubleshooting 2–20
- keyboard connector
 - location 1–15
 - pin assignments A–7

L

- label area 1–21
- LED cover
 - illustrated 3–2
 - removal 5–18
 - spare part number 3–3, 5–18
- left side components 1–12
- Logo Kit, spare part number 3–12

M

- mass storage devices 3–10
 - see also* *diskette drive*
 - CD-ROM drive*
 - DVD-ROM drive hard drive*
- memory expansion board
 - replacement 5–11
 - spare part numbers 3–12, 5–11
- memory expansion
 - compartment 1–20
- memory expansion slot cover 3–2, 3–8
- memory map specifications 6–17
- microphone jack
 - location 1–11
 - pin assignments A–6
- mini PCI compartment 1–21
- mini PCI slot cover 3–2, 3–8
- models 1–2
- modem board
 - illustrated 3–6
 - replacement 5–13
 - spare part numbers 3–7, 5–13
- modem connector
 - location 1–15
 - pin assignments A–2
- modem, troubleshooting 2–22
- monitor connector
 - location 1–15
 - pin assignments A–5

- mouse connector
 - location 1–15
 - pin assignments A–7

N

- network connector
 - location 1–15
 - pin assignment A–1
- network, troubleshooting 2–22
- nonfunctioning device,
 - troubleshooting 2–10, 2–19
- num lock key 1–17
- num lock light 1–18
- numeric keypad 1–17

O

- operating system loading,
 - troubleshooting 2–11
- optical drive
 - illustrated 3–4, 3–10
 - location 1–11
 - removal 5–16
 - spare part numbers 3–5, 3–10, 5–16
- optical drive alignment rail
 - illustrated 3–2, 3–8
 - removal 5–60

P

- packing precautions 4–4
- parallel connector
 - location 1–15
 - pin assignments A–4
- parts catalog 3–1
- password, clearing 1–9
- PC Card eject button 1–13
- PC Card slot 1–13

- PhoenixBIOS Setup Utility
 - 2-1
- plastic parts 4-2
- Plastics and Hardware Kit
 - components 3-3, 3-8
 - spare part number 3-3, 3-8
- pointing device,
 - troubleshooting 2-21
- power button 1-19
- power cord, spare part
 - numbers 3-12
- power light 1-18
- power management features
 - 1-10
- power, troubleshooting 2-4
- processor
 - illustrated 3-4
 - removal 5-34
 - spare part numbers 3-5, 5-34
- processor stopper, removal
 - 5-35
- R**
- real time clock (RTC) battery
 - illustrated 3-4
 - removal 5-36
 - spare part number 3-5, 5-36
- rear panel components 1-14
- removal and replacement
 - preliminaries 4-1
 - procedures 5-1
- right side components 1-11
- RJ-11 jack
 - location 1-15
 - pin assignments A-2
- RJ-45 jack
 - location 1-15
 - pin assignments A-1
- S**
- Screw Kit, spare part number
 - 3-12
- security cable slot 1-13
- serial number 3-1, 5-2
- service considerations 4-2
- side panel
 - illustrated 3-2, 3-8
 - removal 5-48, 5-50
- speaker assembly
 - illustrated 3-6
 - removal 5-52
 - spare part number 3-7
- speaker jack
 - location 1-11
 - pin assignments A-6
- speakers, location 1-19
- specifications
 - AC adapter 6-11
 - battery 6-11
 - CD-ROM drive 6-8
 - CD-RW drive 6-10
 - computer 6-1
 - diskette drive 6-7
 - display 6-3, 6-4
 - DMA 6-12
 - DVD-ROM drive 6-9
 - hard drive 6-5
 - I/O addresses 6-14

- interrupts 6–13
- memory map 6–17
- static shielding materials 4–7
- stereo speaker jack
 - location 1–11
 - pin assignments A–6
- S-video connector
 - location 1–15
 - pin assignments A–3
- system board
 - illustrated 3–6
 - removal 5–58
 - spare part numbers 3–7, 5–58
- system memory map 6–17

T

- Thermal Pad Kit, spare part number 3–5
- thermal pad, replacement 5–33
- tilt feet 1–20
- tools required 4–1
- top components 1–18
- top cover
 - illustrated 3–4
 - removal 5–38
 - spare part number 3–5, 5–38
- TouchPad 1–19
- TouchPad buttons 1–19
- TouchPad cable,
 - disconnecting 5–40

- transporting precautions 4–4
- troubleshooting
 - audio 2–17
 - docking station 2–10
 - flowcharts 2–2
 - keyboard 2–20
 - modem 2–22
 - network 2–22
 - nonfunctioning device
 - 2–10, 2–19
 - operating system loading
 - 2–11
 - overview 2–1
 - pointing device 2–21
 - power 2–4
 - video 2–8

U

- universal serial bus (USB)
 - connector
 - location 1–15
 - pin assignments A–2

V

- vents 1–13, 1–20
- video troubleshooting 2–8
- volume control buttons 1–19

W

- Windows application key
 - 1–17
- Windows logo key 1–17
- workstation precautions 4–5