

SHEET TITLE

01	COVER SHEET
02	BLOCK DIAGRAM
03	BOM & PCB MODIFY HISTORY
04	P4 LGA775 A
05	P4 LGA775 B
06	P4 LGA775 C
07	P4 LGA775 D,E,F,G
08	GMCH-LAKEPORT HOST
09	GMCH-LAKEPORT DDRII
10	GMCH-LAKEPORT PCI E, DMI
11	GMCH-LAKEPORT INT VGA
12	GMCH-LAKEPORT GND
13	GMCH-LAKEPORT PWR
14	DDRII CHANNEL A 1
15	DDRII CHANNEL B 2
16	DDRII TERMINATION
17	PCI EXPRESS*16 SLOT
18	ICH7 PCI, USB, DMI, LAN
19	ICH7 IDE, GPIO, SATA, CTRL
20	ICH7 VCC, GND
21	GB/CK410M-OC CLOCK.
22	PCI SLOT 1,2,3
23	IDE/FLOPPY
24	ITE 8718 GBIX
25	COM LPT
26	BIOS, CI, HWM, KB/MS
27	AZALIA ALC883

SHEET TITLE

28	REAR AUDIO JACK
29	DISCRETE POWER
30	VCORE PWM ISL6312
31	ATX, OTHERS POWER
32	REALTEK RTL8110SC
33	FRONT PANEL

**Gigabyte Technology**

Title	Cover Sheet	
Size	Document Number	Rev
Custom	<b>945GZM-S2</b>	<b>3.0</b>
Date:	Tuesday, December 26, 2006	Sheet 1 of 33

# BLOCK DIAGRAM

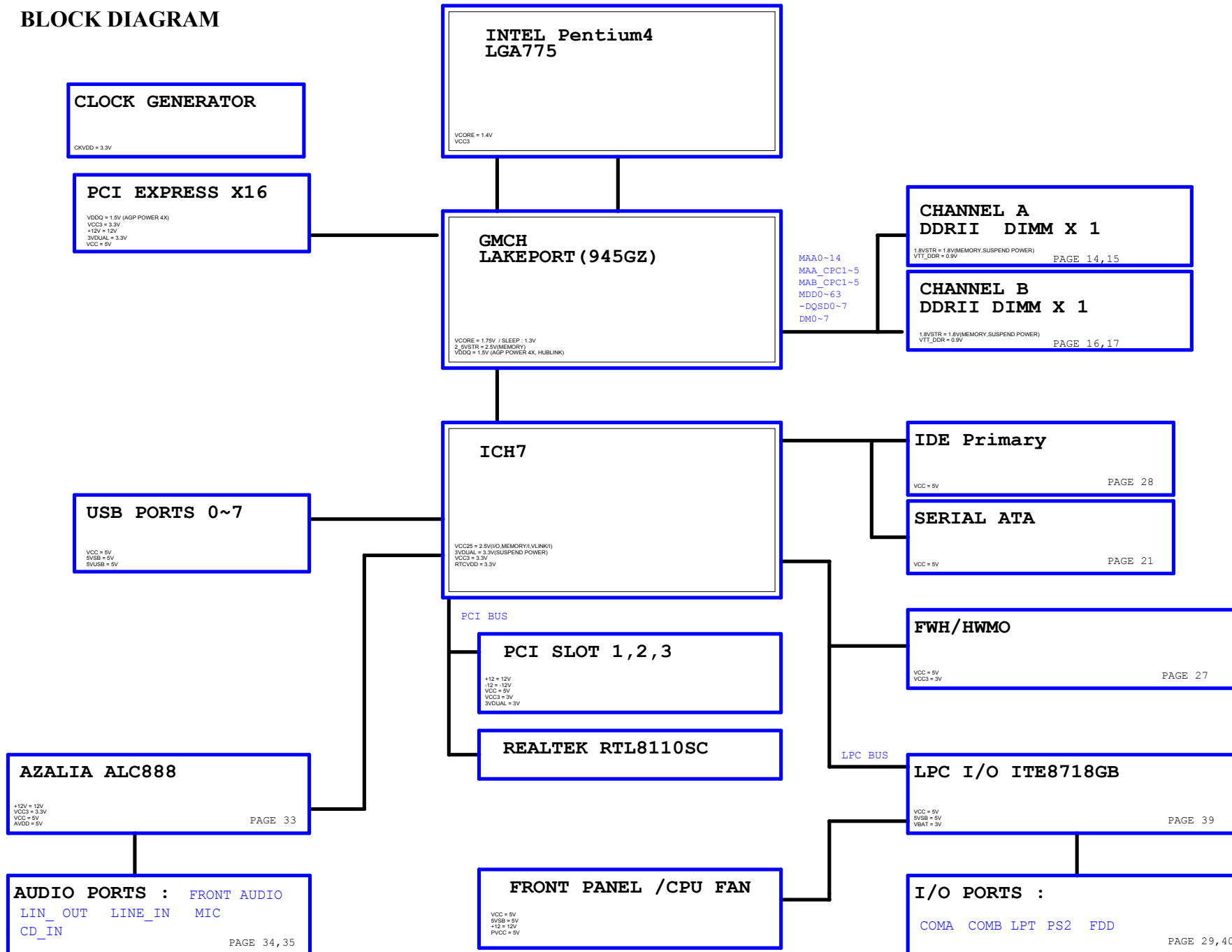





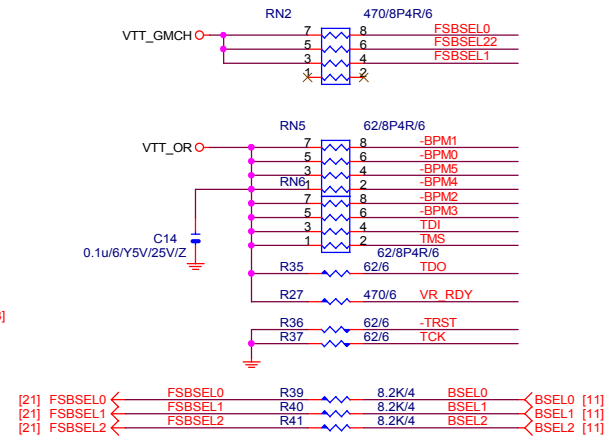
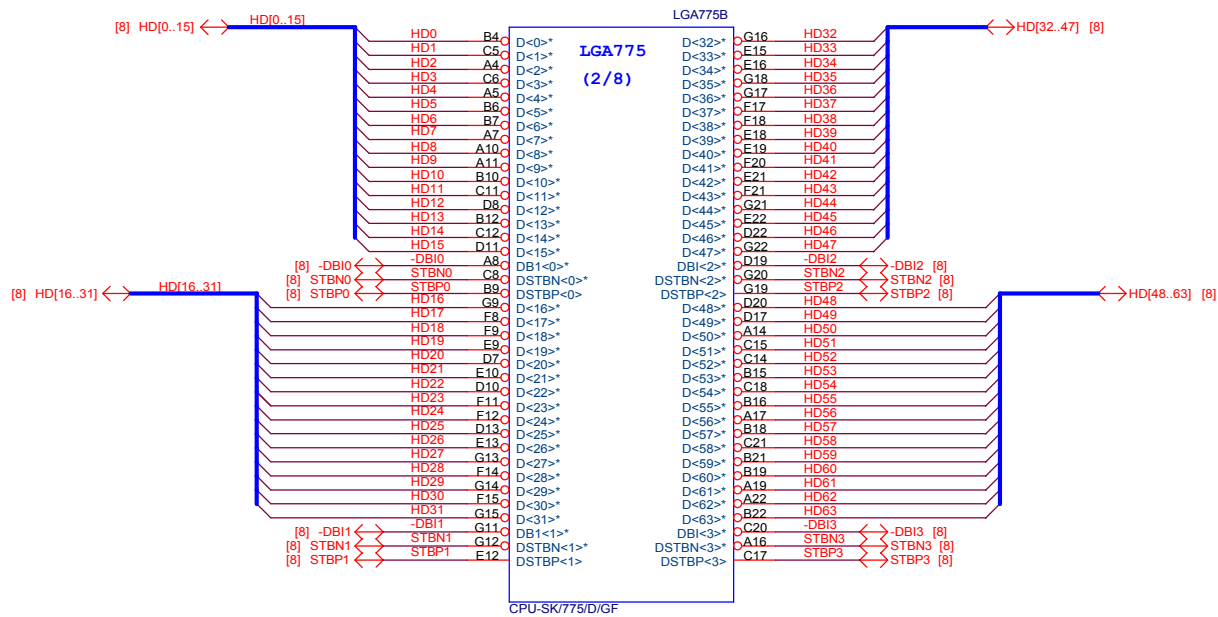

**CPU**

NA	FSB	FSA	Clock
FSBSEL3 = 1	FSBSEL1 = 0	FSBSEL0 = 1	100MHz
FSBSEL3 = 0	FSBSEL1 = 0	FSBSEL0 = 1	133MHz
FSBSEL3 = 0	FSBSEL1 = 1	FSBSEL0 = 1	166MHz
FSBSEL3 = 0	FSBSEL1 = 1	FSBSEL0 = 0	200MHz
FSBSEL3 = 0	FSBSEL1 = 0	FSBSEL0 = 0	266MHz

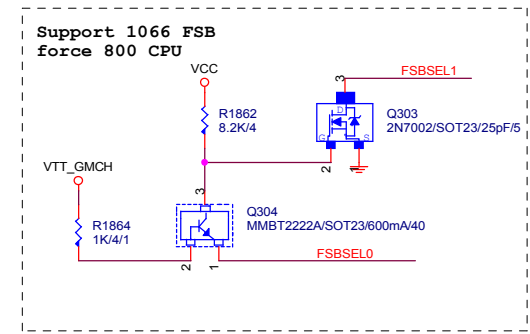
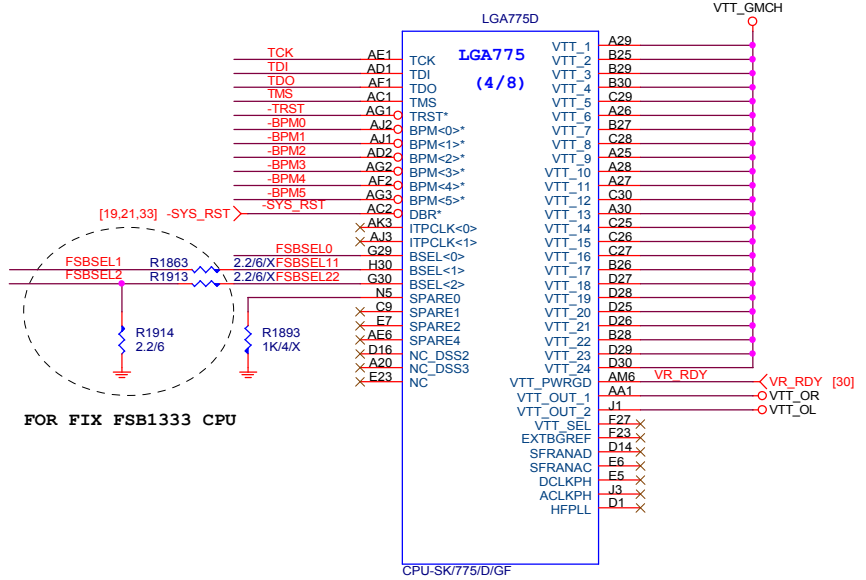

Note:  
VCCA & VCOREPLL  
define doesn't same as  
old P4 design kit

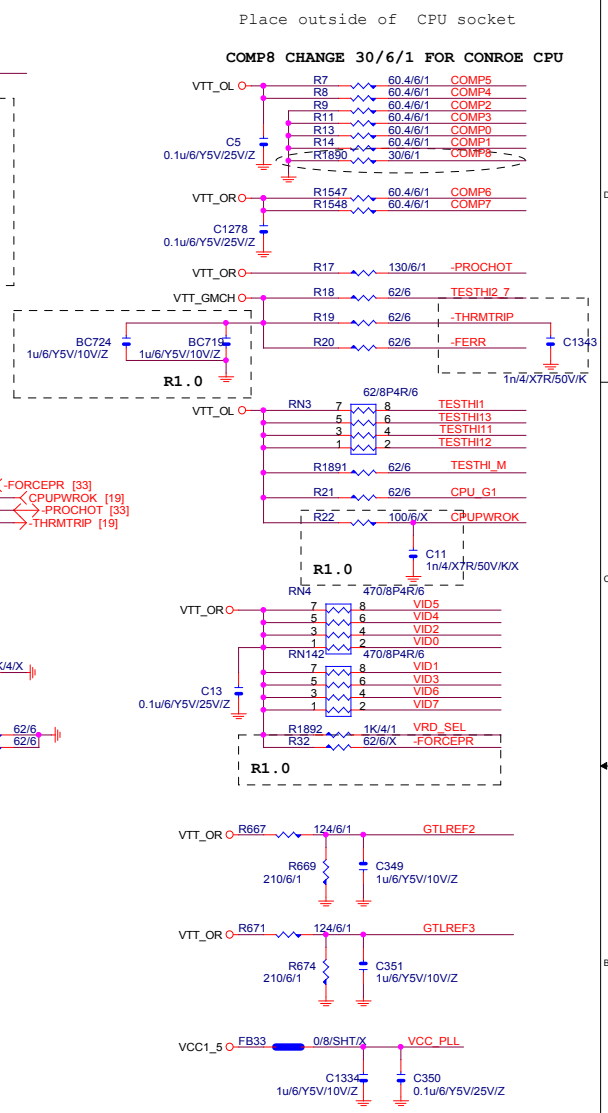
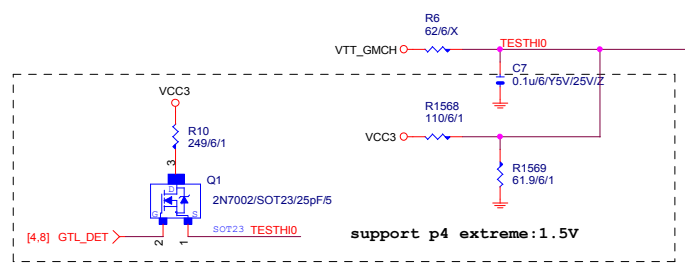
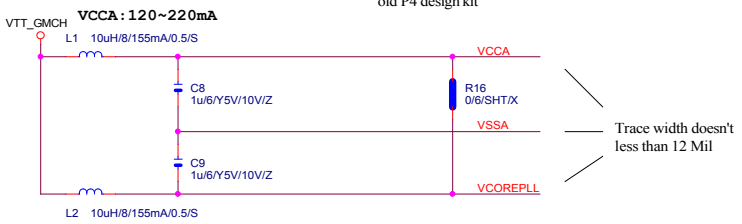

VCOREPLL : 100mA  
As close as possible to  
CPU socket

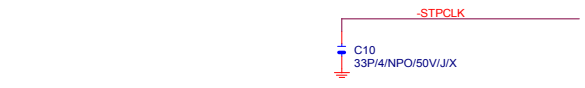

**CPU**

FSA	FSB	NA	Clock	
FSBSEL0	FSBSEL1	FSBSEL3	Clock	X
1	0	1	100MHz	
1	0	0	133MHz	
1	1	0	166MHz	RATIO
0	1	0	200MHz	2.66/3.33
0	0	0	266MHz	2.00/2.5

945 Design Guide rev1.5 spec.  
VCCA=120~220mA  
公板為125mA

10LI2-12100A-13=INDUCTOR 10uH 300mA TAI-TECH  
10LI2-12100A-02=INDUCTOR 10uH 155mA TAIYO  
10LI2-12100A-01=INDUCTOR 10uH 120mA TDK

限用兩種

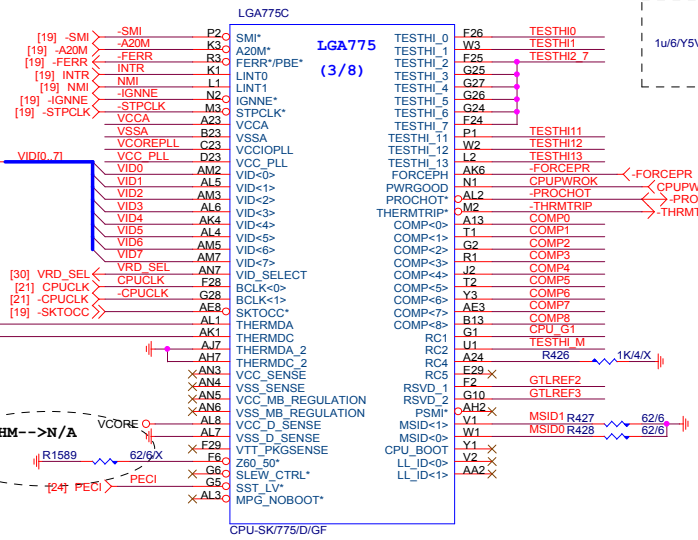

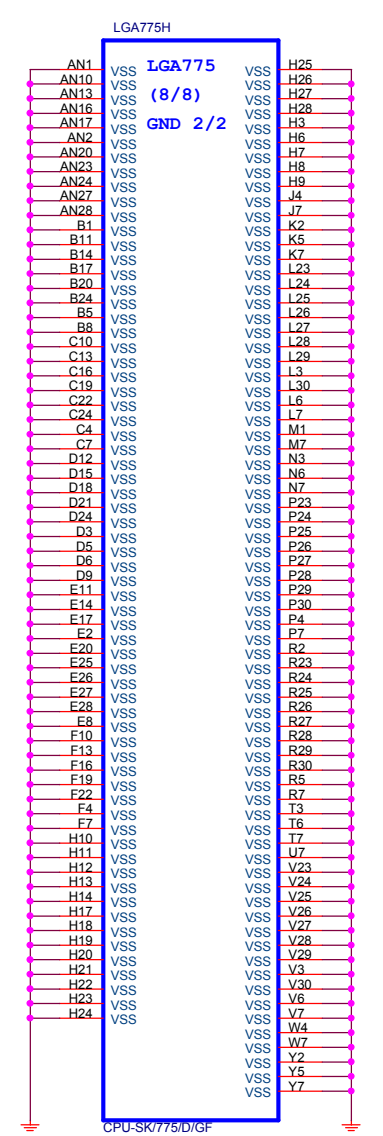
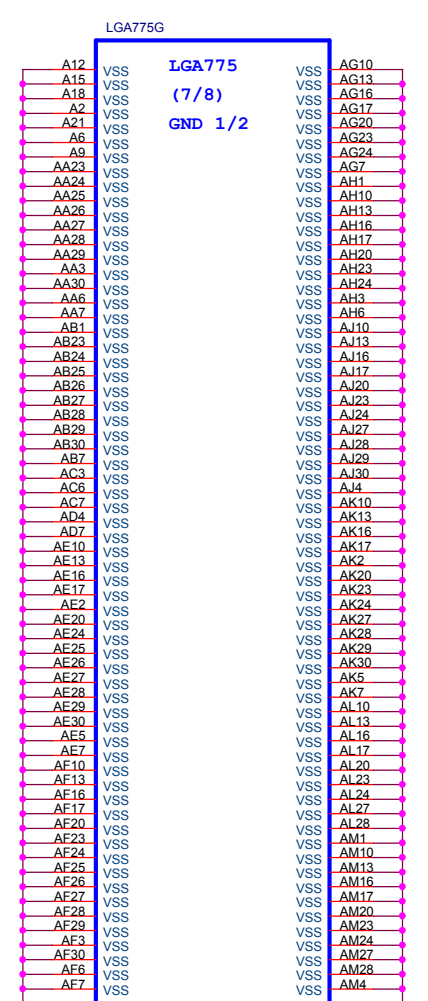
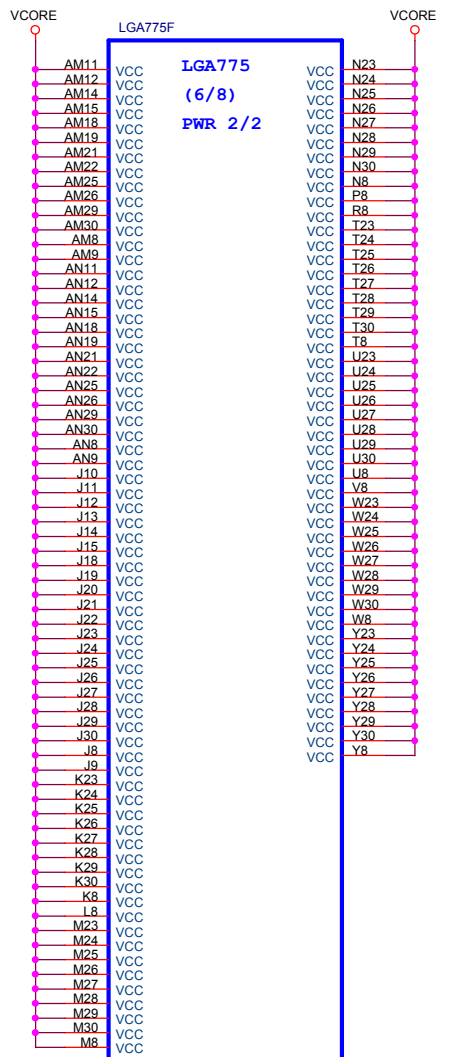
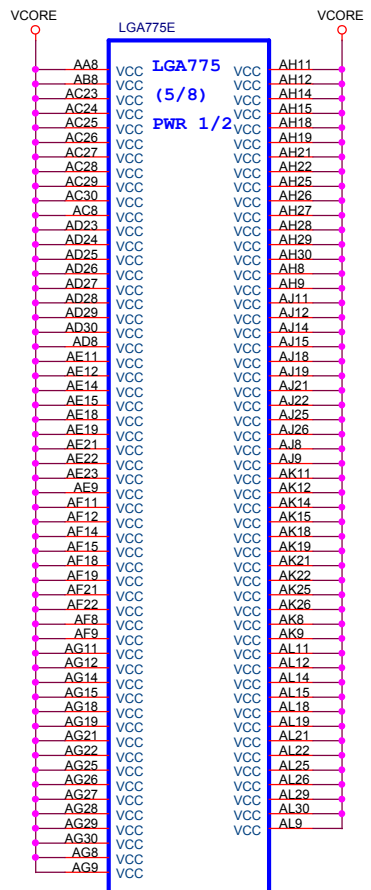

<b>Gigabyte Technology</b>		
Title <b>P4_LGA775-E,F,G,H</b>		
Size B	Document Number <b>945GZM-S2</b>	Rev <b>3.0</b>
Date: Tuesday, December 26, 2006	Sheet 7	of 33





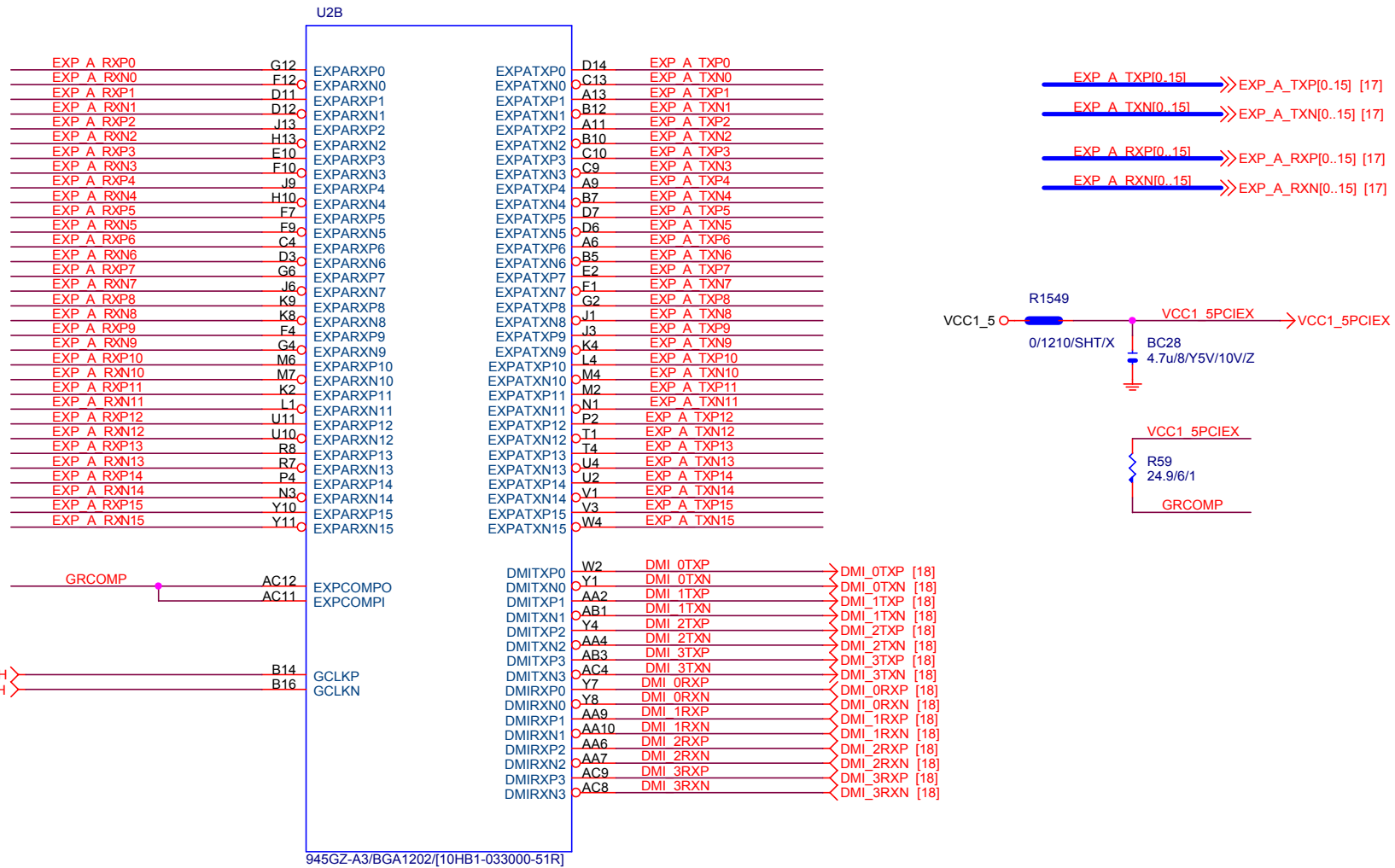

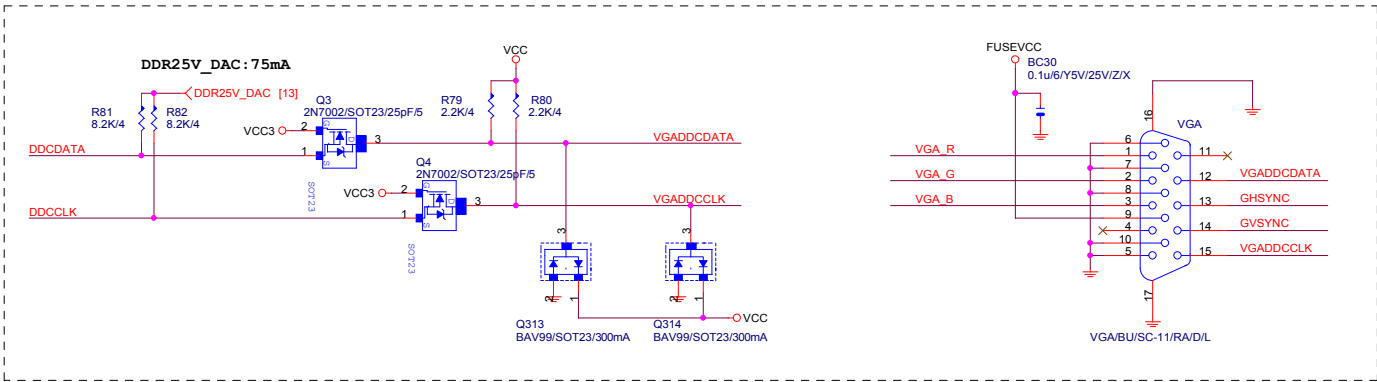
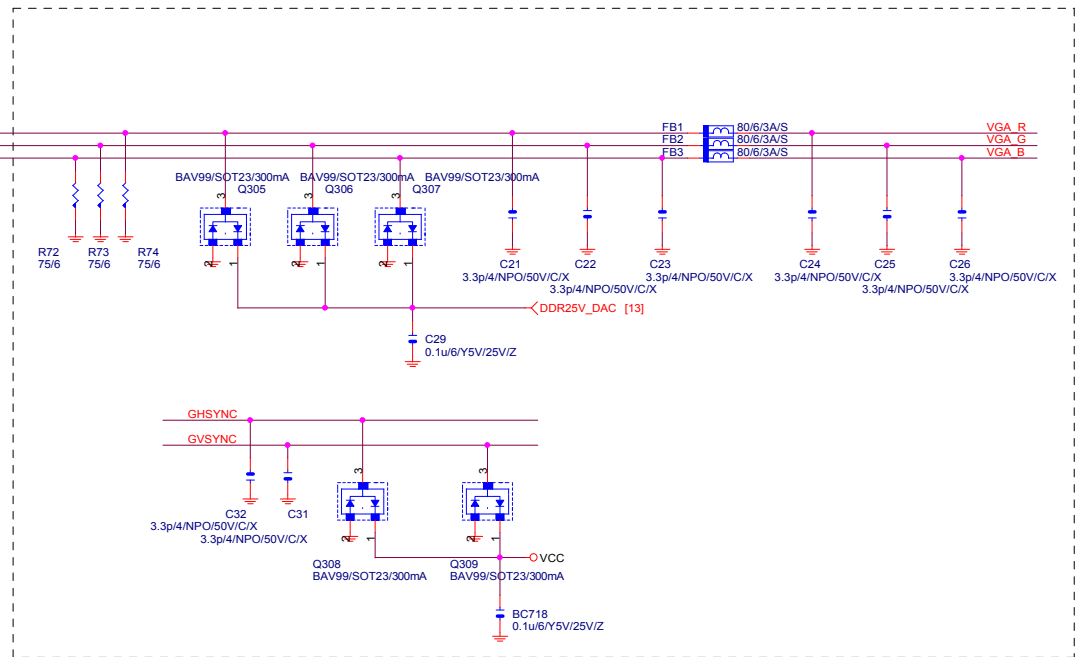
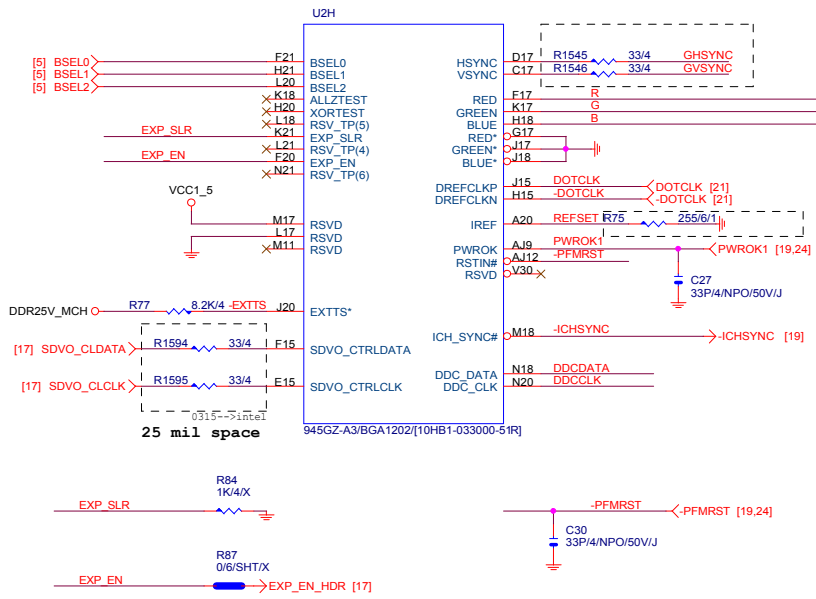

U2C

A4	VSS	N2
A16	VSS	N6
A22	VSS	N8
A26	VSS	N13
A31	VSS	N15
A35	VSS	N24
B4	VSS	N26
B6	VSS	N27
B9	VSS	N29
B11	VSS	N31
B13	VSS	N33
B21	VSS	N36
B22	VSS	N39
B28	VSS	N43
B33	VSS	P3
B38	VSS	P14
C3	VSS	P15
C7	VSS	P24
C12	VSS	P26
C14	VSS	P27
C22	VSS	P29
C40	VSS	P30
D2	VSS	R6
D5	VSS	R9
D10	VSS	R12
D16	VSS	R14
D20	VSS	R30
D21	VSS	R30
E3	VSS	R31
E4	VSS	R34
E7	VSS	R37
E9	VSS	R39
F12	VSS	T2
F13	VSS	T2
F17	VSS	T2
F18	VSS	T2
F20	VSS	T2
F21	VSS	T2
F32	VSS	T2
F2	VSS	U3
F13	VSS	U3
F18	VSS	U3
F26	VSS	U3
F34	VSS	U3
G3	VSS	U3
G5	VSS	U3
G7	VSS	U3
G9	VSS	U3
G10	VSS	U3
G13	VSS	U3
G15	VSS	U3
G18	VSS	U3
G20	VSS	U3
G21	VSS	U3
G24	VSS	U3
G27	VSS	U3
G29	VSS	U3
G31	VSS	U3
G32	VSS	U3
G35	VSS	U3
G38	VSS	U3
H12	VSS	U3
H17	VSS	U3
H26	VSS	U3
H27	VSS	U3
H32	VSS	U3
J2	VSS	U3
J5	VSS	U3
J7	VSS	U3
J10	VSS	U3
J12	VSS	U3
J21	VSS	U3
J24	VSS	U3
J29	VSS	U3
J38	VSS	U3
J43	VSS	U3
K3	VSS	U3
K5	VSS	U3
K6	VSS	U3
K7	VSS	U3
K10	VSS	U3
K12	VSS	U3
K13	VSS	U3
K15	VSS	U3
K20	VSS	U3
K27	VSS	U3
K32	VSS	U3
K34	VSS	U3
K37	VSS	U3
K39	VSS	U3
L2	VSS	U3
L12	VSS	U3
L13	VSS	U3
L24	VSS	U3
L26	VSS	U3
L29	VSS	U3
L31	VSS	U3
L42	VSS	U3
M3	VSS	U3
M5	VSS	U3
M8	VSS	U3
M9	VSS	U3
M10	VSS	U3
M13	VSS	U3
M20	VSS	U3
M21	VSS	U3
M35	VSS	U3
M37	VSS	U3

945GZ-A3/BGA1202[10HB1-033000-51R]

U2E

AD7	VSS	AD7
AD9	VSS	AD9
AD11	VSS	AD11
AD13	VSS	AD13
AD33	VSS	AD33
N24	VSS	N24
AD37	VSS	AD37
AD42	VSS	AD42
AF1	VSS	AF1
AF2	VSS	AF2
N33	VSS	N33
AF5	VSS	AF5
N39	VSS	N39
AF36	VSS	AF36
P3	VSS	P3
P14	VSS	P14
P15	VSS	P15
AG30	VSS	AG30
AG31	VSS	AG31
AG33	VSS	AG33
AG36	VSS	AG36
AG37	VSS	AG37
AG38	VSS	AG38
AG39	VSS	AG39
AH42	VSS	AH42
R12	VSS	R12
A10	VSS	A10
A30	VSS	A30
A31	VSS	A31
A33	VSS	A33
A35	VSS	A35
A37	VSS	A37
Ak24	VSS	Ak24
Ak26	VSS	Ak26
Ak29	VSS	Ak29
Ak30	VSS	Ak30
AL1	VSS	AL1
AL3	VSS	AL3
AL7	VSS	AL7
AL10	VSS	AL10
AL12	VSS	AL12
AL13	VSS	AL13
AL15	VSS	AL15
AL18	VSS	AL18
AL21	VSS	AL21
AL23	VSS	AL23
AL24	VSS	AL24
AL27	VSS	AL27
AL32	VSS	AL32
AL33	VSS	AL33
V38	VSS	V38
AL43	VSS	AL43
V39	VSS	V39
AM5	VSS	AM5
AM7	VSS	AM7
Y2	VSS	Y2
AM3	VSS	AM3
AM33	VSS	AM33
Y6	VSS	Y6
AM36	VSS	AM36
Y9	VSS	Y9
AM37	VSS	AM37
AM39	VSS	AM39
Y12	VSS	Y12
AN2	VSS	AN2
Y31	VSS	Y31
AN4	VSS	AN4
Y35	VSS	Y35
AN13	VSS	AN13
Y37	VSS	Y37
AN15	VSS	AN15
AN17	VSS	AN17
AN18	VSS	AN18
AN20	VSS	AN20
AN21	VSS	AN21
AN23	VSS	AN23
AN24	VSS	AN24
AN26	VSS	AN26
AN27	VSS	AN27
AN31	VSS	AN31
AN42	VSS	AN42
AP5	VSS	AP5
AP7	VSS	AP7
AP10	VSS	AP10
AP12	VSS	AP12
AP29	VSS	AP29
AP34	VSS	AP34
AP38	VSS	AP38
AR1	VSS	AR1
AR6	VSS	AR6
AR15	VSS	AR15
AR20	VSS	AR20
AR24	VSS	AR24
AR32	VSS	AR32
AR37	VSS	AR37
AR39	VSS	AR39
AR43	VSS	AR43
AT12	VSS	AT12
AT17	VSS	AT17
AT18	VSS	AT18
AT21	VSS	AT21
AT23	VSS	AT23
AT26	VSS	AT26
AT27	VSS	AT27
AT31	VSS	AT31
AU6	VSS	AU6
AU9	VSS	AU9
AU12	VSS	AU12
AU13	VSS	AU13
AU15	VSS	AU15
AU17	VSS	AU17
AU20	VSS	AU20
AD18	VSS	AD18
AD20	VSS	AD20
AD22	VSS	AD22
AD24	VSS	AD24
AD27	VSS	AD27
AD29	VSS	AD29
AE19	VSS	AE19
AE21	VSS	AE21
AE23	VSS	AE23
AE25	VSS	AE25
AF18	VSS	AF18
AF20	VSS	AF20
AF22	VSS	AF22
AF24	VSS	AF24
AY1	VSS	AY1
BC4	VSS	BC4

VSS	AU21
VSS	AU24
VSS	AU26
VSS	AU29
VSS	AU32
VSS	AU34
VSS	AV2
VSS	AV10
VSS	AV17
VSS	AV37
VSS	AW10
VSS	BA4
VSS	BA42
VSS	BB3
VSS	BB6
VSS	BB11
VSS	BB14
VSS	BB19
VSS	BB34
VSS	BB39
VSS	BB41
VSS	BC9
VSS	A40
VSS	D1
VSS	D43
VSS	R26
VSS	R29
VSS	U29
VSS	V24
VSS	V26
VSS	V29
VSS	W21
VSS	W23
VSS	W25
VSS	Y20
VSS	Y22
VSS	Y24
VSS	Y26
VSS	Y29
VSS	AA27
VSS	AA29
VSS	AC19
VSS	AC26
VSS	AC29
NC	A42
NC	B2
NC	B3
NC	B4
NC	B42
NC	B43
NC	C2
NC	C42
NC	E35
NC	AV26
NC	AV27
NC	AW2
NC	AW26
NC	BA2
NC	BB1
NC	BB2
NC	BB43
NC	BC1
NC	BC2
NC	BC42
NC	BC43
RSVD	AK21
RSVD	AJ23
RSVD	AJ26
RSVD	AL20
RSVD	AL21
RSVD	AJ21
RSVD	AL26
RSVD	AK27
RSVD	AD30
RSVD	AC34
RSVD	Y30
RSVD	Y31
RSVD	AF31
RSVD	AD31
RSVD	U30
RSVD	V31
RSVD	AA30
RSVD	AC30
RSVD	AA3
RSVD	AG26
RSVD	AG28
RSVD	AG27
RSVD	AJ24
RSVD	AJ27
RSVD	AK40
RSVD	AW17
RSVD	AW19
RSVD	AY14
RSVD	BC16
RSVD	AJ25
RSVD	AG29

945GZ-A3/BGA1202[10HB1-033000-51R]

**Gigabyte Technology**

Title			GMCH-GND		
Size	Document Number	945GZM-S2		Rev	3.0
Date	Tuesday, December 26, 2006	Sheet	12	of	33





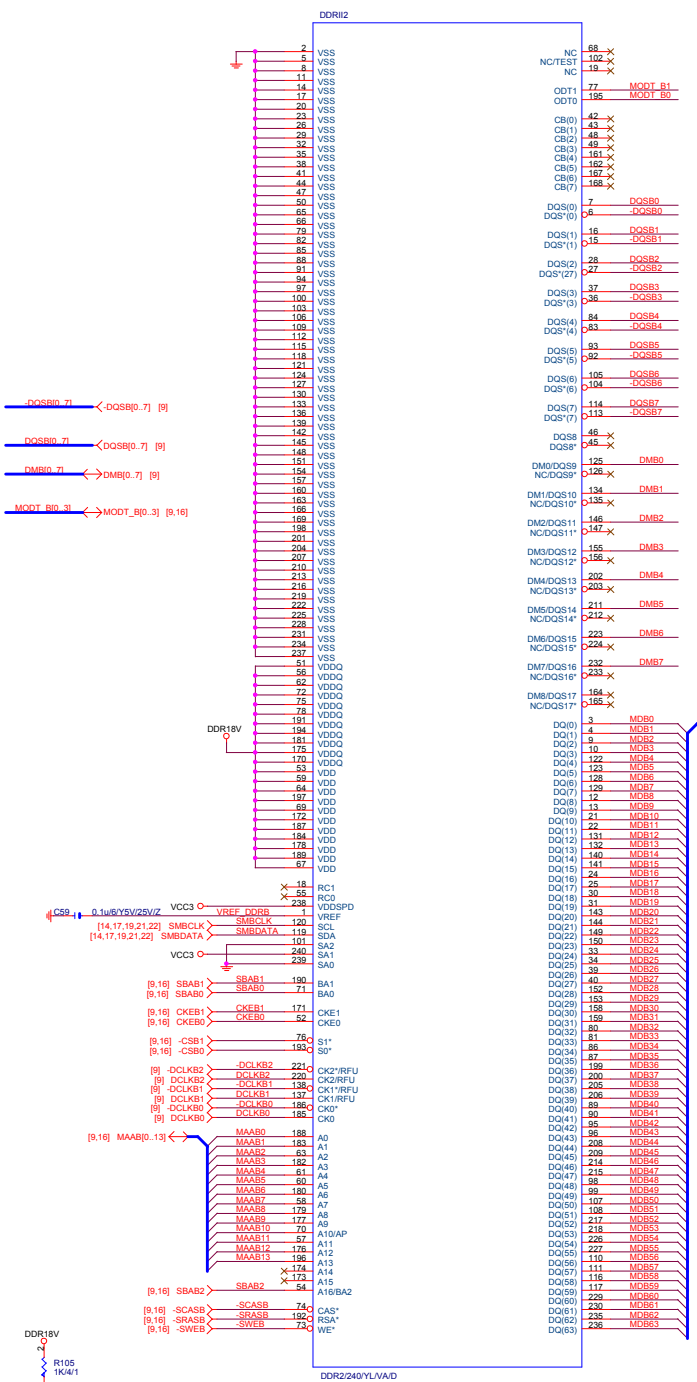

NC	68	X
NC/TEST	102	X
NC	19	X
ODT1	77	MODT_B1
ODT0	195	MODT_B0
CB(0)	42	X
CB(1)	43	X
CB(2)	48	X
CB(3)	49	X
CB(4)	161	X
CB(5)	162	X
CB(6)	167	X
CB(7)	168	X
DQS(0)	7	DQS0
DQS(0)	6	DQS0
DQS(1)	16	DQS1
DQS(1)	15	DQS1
DQS(2)	28	DQS2
DQS(2)	27	DQS2
DQS(3)	37	DQS3
DQS(3)	36	DQS3
DQS(4)	84	DQS4
DQS(4)	83	DQS4
DQS(5)	83	DQS5
DQS(5)	82	DQS5
DQS(6)	105	DQS6
DQS(6)	104	DQS6
DQS(7)	114	DQS7
DQS(7)	113	DQS7
DQS8	46	X
DQS8	45	X
DM0/DQS9	125	DMB0
NC/DQS9	126	X
DM1/DOS10	134	DMB1
NC/DOS10	135	X
DM5/DOS11	146	DMB2
NC/DOS11	147	X
DM5/DOS12	155	DMB3
NC/DOS12	156	X
DM4/DOS13	202	DMB4
NC/DOS13	203	X
DM5/DOS14	211	DMB5
NC/DOS14	212	X
DM6/DOS15	223	DMB6
NC/DOS15	224	X
DM7/DOS16	232	DMB7
NC/DOS16	233	X
DM8/DOS17	184	X
NC/DOS17	185	X
DQ(0)	3	MDB0
DQ(1)	4	MDB1
DQ(2)	9	MDB2
DQ(2)	10	MDB3
DQ(3)	122	MDB4
DQ(4)	123	MDB5
DQ(5)	128	MDB6
DQ(6)	129	MDB7
DQ(7)	12	MDB8
DQ(8)	13	MDB9
DQ(9)	21	MDB10
DQ(10)	22	MDB11
DQ(11)	131	MDB12
DQ(12)	132	MDB13
DQ(13)	140	MDB14
DQ(14)	141	MDB15
DQ(15)	24	MDB16
DQ(16)	25	MDB17
DQ(17)	30	MDB18
DQ(18)	31	MDB19
DQ(19)	143	MDB20
DQ(20)	144	MDB21
DQ(21)	149	MDB22
DQ(22)	150	MDB23
DQ(23)	34	MDB24
DQ(24)	33	MDB25
DQ(25)	34	MDB26
DQ(26)	39	MDB27
DQ(27)	40	MDB28
DQ(28)	152	MDB29
DQ(29)	153	MDB30
DQ(30)	158	MDB31
DQ(31)	159	MDB32
DQ(32)	80	MDB33
DQ(33)	81	MDB34
DQ(34)	86	MDB35
DQ(35)	87	MDB36
DQ(36)	199	MDB37
DQ(37)	200	MDB38
DQ(38)	206	MDB39
DQ(39)	89	MDB40
DQ(40)	90	MDB41
DQ(41)	95	MDB42
DQ(42)	96	MDB43
DQ(43)	208	MDB44
DQ(44)	208	MDB45
DQ(45)	214	MDB46
DQ(46)	215	MDB47
DQ(47)	98	MDB48
DQ(48)	99	MDB49
DQ(49)	107	MDB50
DQ(50)	108	MDB51
DQ(51)	217	MDB52
DQ(52)	218	MDB53
DQ(53)	226	MDB54
DQ(54)	227	MDB55
DQ(55)	110	MDB56
DQ(56)	111	MDB57
DQ(57)	116	MDB58
DQ(58)	117	MDB59
DQ(59)	229	MDB60
DQ(60)	230	MDB61
DQ(61)	235	MDB62
DQ(62)	236	MDB63
DQ(63)		

MDB[0..63] [9]

**Gigabyte Technology**

Title		DDRII CHANNEL B	
Size	Document Number	945GZM-S2	
Column	Rev.	3.0	
Date	Sheet	15	of 33

# DDR TERMINATION CHANNEL A

## DDRVTT Decouple

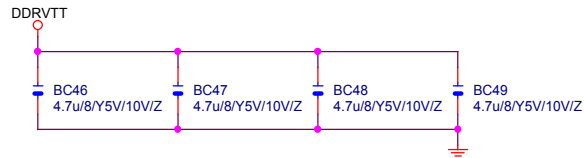

## DDR18V Decouple

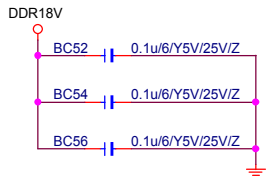

## DDRVTT Decouple

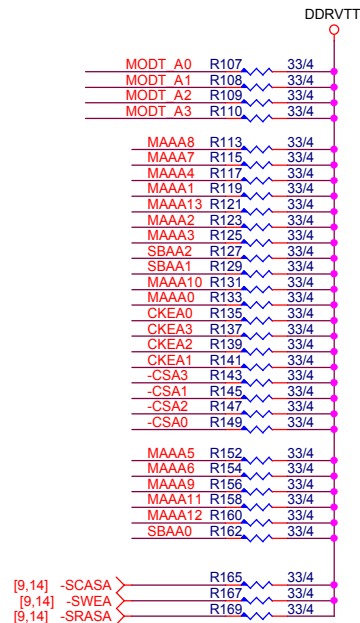
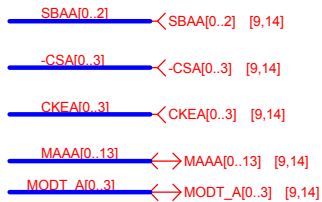
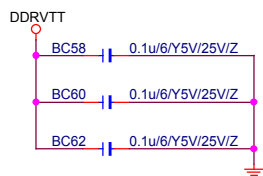

# DDR TERMINATION CHANNEL B

## DDR18V Decouple

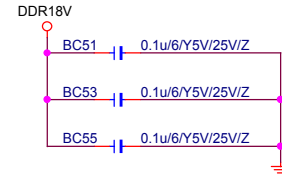

## DDRVTT Decouple

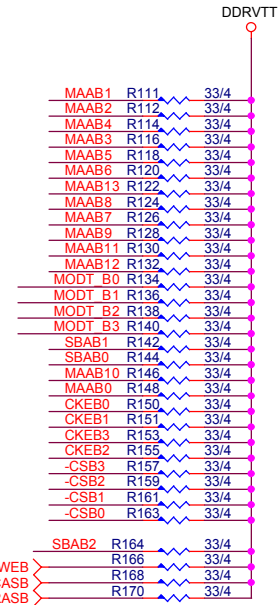
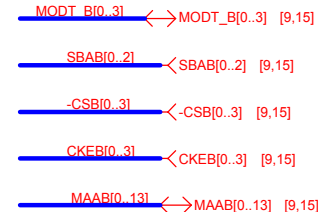
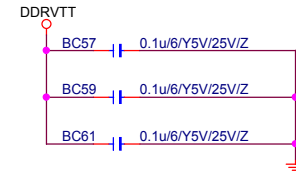

**Gigabyte Technology**

Title		
DDRII TERMINATOR		
Size Custom	Document Number	Rev
	<b>945GZM-S2</b>	<b>3.0</b>
Date:	Tuesday, December 26, 2006	Sheet 16 of 33

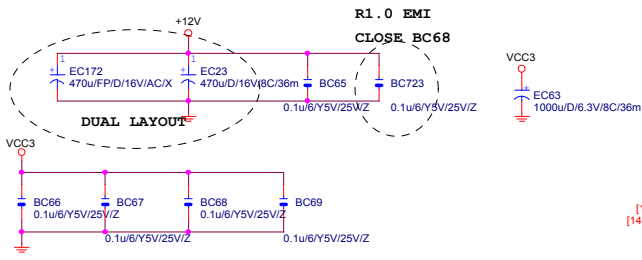

EXP_A_TXP0	C92	0.1u/4Y5V/16V/Z/X	EXP_A_TXP0C
EXP_A_TXN0	C93	0.1u/4Y5V/16V/Z/X	EXP_A_TXN0C
EXP_A_RXP0	C94	0.1u/4Y5V/16V/Z/X	EXP_A_RXP0C
EXP_A_RXN0	C95	0.1u/4Y5V/16V/Z/X	EXP_A_RXN0C
EXP_A_TXP1	C96	0.1u/4Y5V/16V/Z/X	EXP_A_TXP1C
EXP_A_TXN1	C97	0.1u/4Y5V/16V/Z/X	EXP_A_TXN1C
EXP_A_RXP1	C98	0.1u/4Y5V/16V/Z/X	EXP_A_RXP1C
EXP_A_RXN1	C99	0.1u/4Y5V/16V/Z/X	EXP_A_RXN1C
EXP_A_TXP2	C100	0.1u/4Y5V/16V/Z/X	EXP_A_TXP2C
EXP_A_TXN2	C101	0.1u/4Y5V/16V/Z/X	EXP_A_TXN2C
EXP_A_RXP2	C102	0.1u/4Y5V/16V/Z/X	EXP_A_RXP2C
EXP_A_RXN2	C103	0.1u/4Y5V/16V/Z/X	EXP_A_RXN2C
EXP_A_TXP3	C104	0.1u/4Y5V/16V/Z/X	EXP_A_TXP3C
EXP_A_TXN3	C105	0.1u/4Y5V/16V/Z/X	EXP_A_TXN3C
EXP_A_RXP3	C106	0.1u/4Y5V/16V/Z/X	EXP_A_RXP3C
EXP_A_RXN3	C107	0.1u/4Y5V/16V/Z/X	EXP_A_RXN3C
EXP_A_TXP4	C108	0.1u/4Y5V/16V/Z/X	EXP_A_TXP4C
EXP_A_TXN4	C109	0.1u/4Y5V/16V/Z/X	EXP_A_TXN4C
EXP_A_RXP4	C110	0.1u/4Y5V/16V/Z/X	EXP_A_RXP4C
EXP_A_RXN4	C111	0.1u/4Y5V/16V/Z/X	EXP_A_RXN4C
EXP_A_TXP5	C112	0.1u/4Y5V/16V/Z/X	EXP_A_TXP5C
EXP_A_TXN5	C113	0.1u/4Y5V/16V/Z/X	EXP_A_TXN5C
EXP_A_RXP5	C114	0.1u/4Y5V/16V/Z/X	EXP_A_RXP5C
EXP_A_RXN5	C115	0.1u/4Y5V/16V/Z/X	EXP_A_RXN5C
EXP_A_TXP6	C116	0.1u/4Y5V/16V/Z/X	EXP_A_TXP6C
EXP_A_TXN6	C117	0.1u/4Y5V/16V/Z/X	EXP_A_TXN6C
EXP_A_RXP6	C118	0.1u/4Y5V/16V/Z/X	EXP_A_RXP6C
EXP_A_RXN6	C119	0.1u/4Y5V/16V/Z/X	EXP_A_RXN6C
EXP_A_TXP7	C120	0.1u/4Y5V/16V/Z/X	EXP_A_TXP7C
EXP_A_TXN7	C121	0.1u/4Y5V/16V/Z/X	EXP_A_TXN7C
EXP_A_RXP7	C122	0.1u/4Y5V/16V/Z/X	EXP_A_RXP7C
EXP_A_RXN7	C123	0.1u/4Y5V/16V/Z/X	EXP_A_RXN7C

EXP_A_RXP0	SR1	0/4/X	EXP_A_RXP0C
EXP_A_RXN0	SR2	0/4/X	EXP_A_RXN0C
EXP_A_RXP1	SR3	0/4/X	EXP_A_RXP1C
EXP_A_RXN1	SR4	0/4/X	EXP_A_RXN1C
EXP_A_RXP2	SR5	0/4/X	EXP_A_RXP2C
EXP_A_RXN2	SR6	0/4/X	EXP_A_RXN2C
EXP_A_RXP3	SR7	0/4/X	EXP_A_RXP3C
EXP_A_RXN3	SR8	0/4/X	EXP_A_RXN3C
EXP_A_RXP4	SR9	0/4/X	EXP_A_RXP4C
EXP_A_RXN4	SR10	0/4/X	EXP_A_RXN4C
EXP_A_RXP5	SR11	0/4/X	EXP_A_RXP5C
EXP_A_RXN5	SR12	0/4/X	EXP_A_RXN5C
EXP_A_RXP6	SR13	0/4/X	EXP_A_RXP6C
EXP_A_RXN6	SR14	0/4/X	EXP_A_RXN6C
EXP_A_RXP7	SR15	0/4/X	EXP_A_RXP7C
EXP_A_RXN7	SR16	0/4/X	EXP_A_RXN7C
EXP_A_RXP8	SR17	0/4/X	EXP_A_RXP8C
EXP_A_RXN8	SR18	0/4/X	EXP_A_RXN8C
EXP_A_RXP9	SR19	0/4/X	EXP_A_RXP9C
EXP_A_RXN9	SR20	0/4/X	EXP_A_RXN9C
EXP_A_RXP10	SR21	0/4/X	EXP_A_RXP10C
EXP_A_RXN10	SR22	0/4/X	EXP_A_RXN10C
EXP_A_RXP11	SR23	0/4/X	EXP_A_RXP11C
EXP_A_RXN11	SR24	0/4/X	EXP_A_RXN11C
EXP_A_RXP12	SR25	0/4/X	EXP_A_RXP12C
EXP_A_RXN12	SR26	0/4/X	EXP_A_RXN12C
EXP_A_RXP13	SR27	0/4/X	EXP_A_RXP13C
EXP_A_RXN13	SR28	0/4/X	EXP_A_RXN13C
EXP_A_RXP14	SR29	0/4/X	EXP_A_RXP14C
EXP_A_RXN14	SR30	0/4/X	EXP_A_RXN14C
EXP_A_RXP15	SR31	0/4/X	EXP_A_RXP15C
EXP_A_RXN15	SR32	0/4/X	EXP_A_RXN15C

[18] PCIE_OP0	PCIE_OP0	SR49	0/4/SHT/X	EXP_A_TXP0C
[18] PCIE_ON0	PCIE_ON0	SR50	0/4/SHT/X	EXP_A_TXN0C
[18] PCIE_OP1	PCIE_OP1	SR51	0/4/SHT/X	EXP_A_TXP1C
[18] PCIE_ON1	PCIE_ON1	SR52	0/4/SHT/X	EXP_A_TXN1C
[18] PCIE_OP2	PCIE_OP2	SR37	0/4/SHT/X	EXP_A_TXP2C
[18] PCIE_ON2	PCIE_ON2	SR38	0/4/SHT/X	EXP_A_TXN2C
[18] PCIE_OP3	PCIE_OP3	SR39	0/4/SHT/X	EXP_A_TXP3C
[18] PCIE_ON3	PCIE_ON3	SR40	0/4/SHT/X	EXP_A_TXN3C

[18] PCIE_IP0	PCIE_IP0	SR53	0/4/SHT/X	EXP_A_RXP0C
[18] PCIE_IN0	PCIE_IN0	SR54	0/4/SHT/X	EXP_A_RXN0C
[18] PCIE_IP1	PCIE_IP1	SR55	0/4/SHT/X	EXP_A_RXP1C
[18] PCIE_IN1	PCIE_IN1	SR56	0/4/SHT/X	EXP_A_RXN1C
[18] PCIE_IP2	PCIE_IP2	SR45	0/4/SHT/X	EXP_A_RXP2C
[18] PCIE_IN2	PCIE_IN2	SR46	0/4/SHT/X	EXP_A_RXN2C
[18] PCIE_IP3	PCIE_IP3	SR47	0/4/SHT/X	EXP_A_RXP3C
[18] PCIE_IN3	PCIE_IN3	SR48	0/4/SHT/X	EXP_A_RXN3C

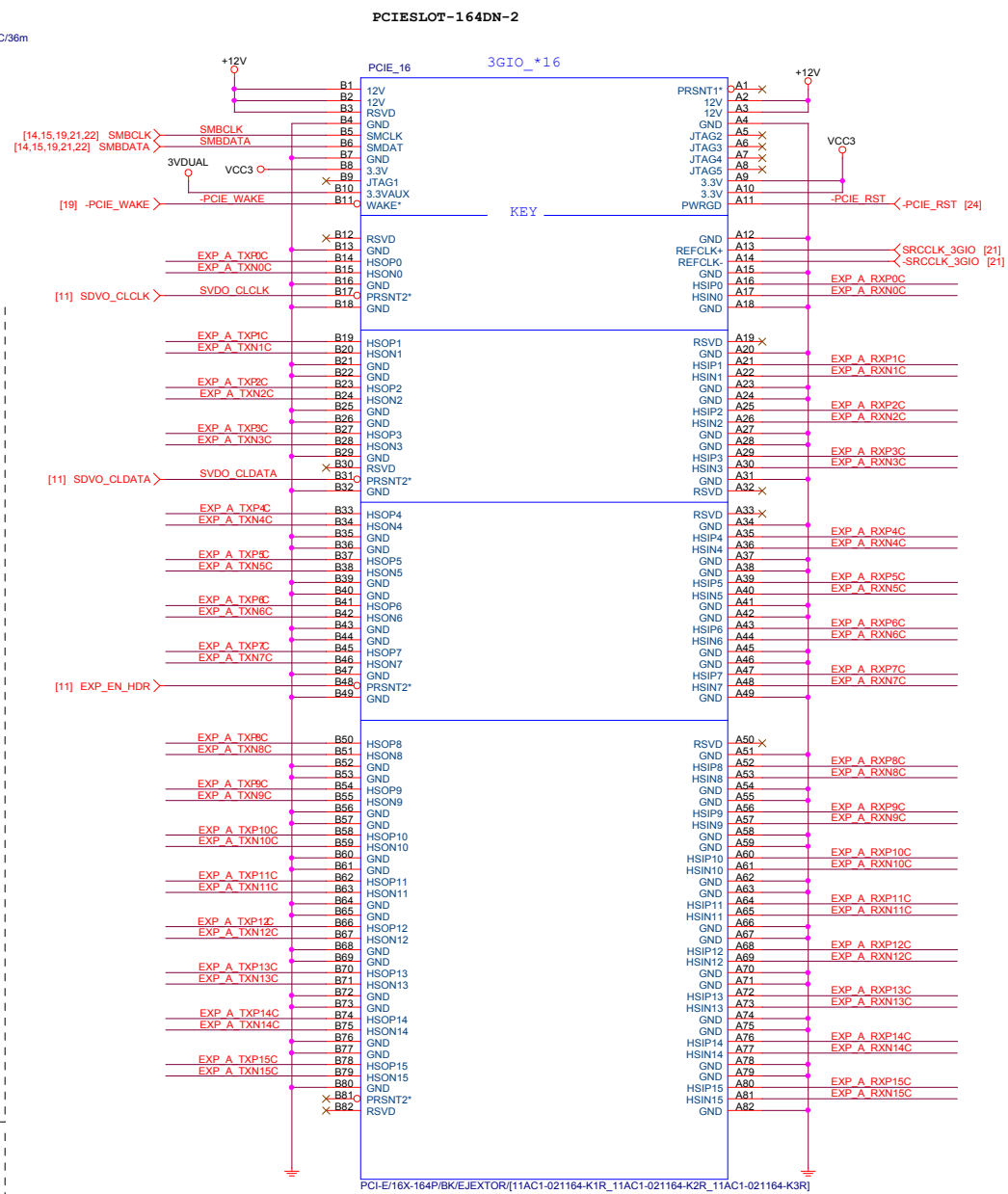

**Gigabyte Technology**

**PCI EXPRESS \* 16**

Title	Document Number	Rev
	<b>945GZM-S2</b>	<b>3.0</b>
Date:	Tuesday, December 26, 2006	Sheet 17 of 33

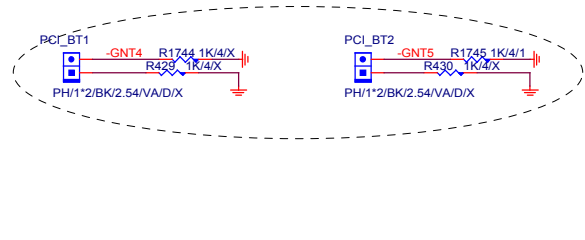
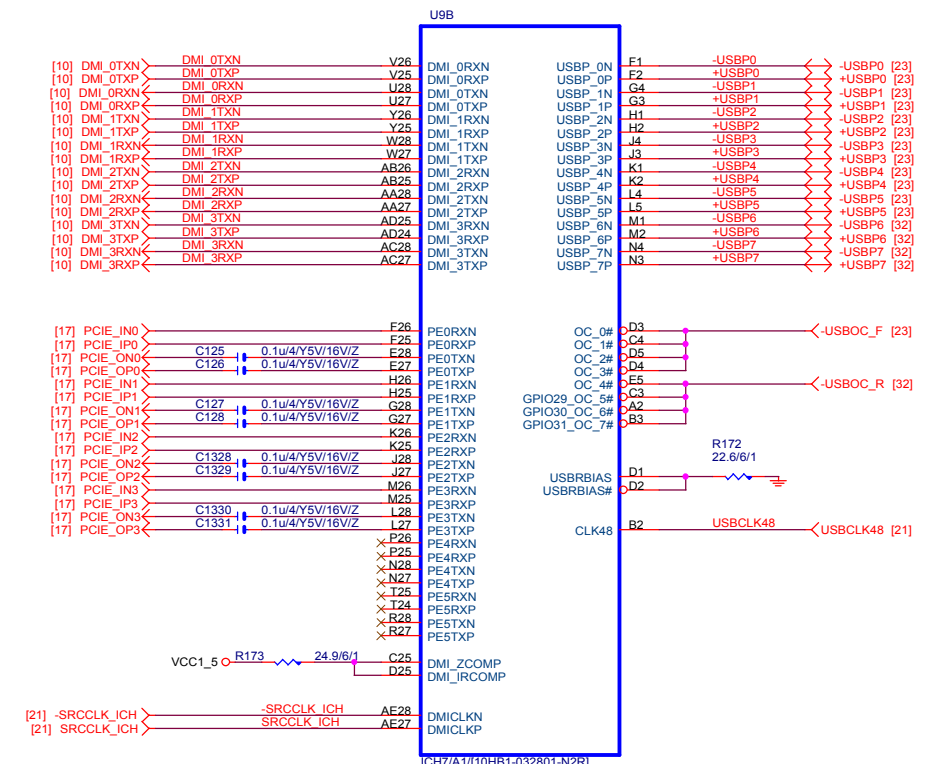
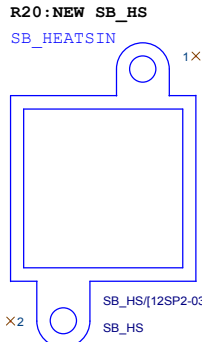
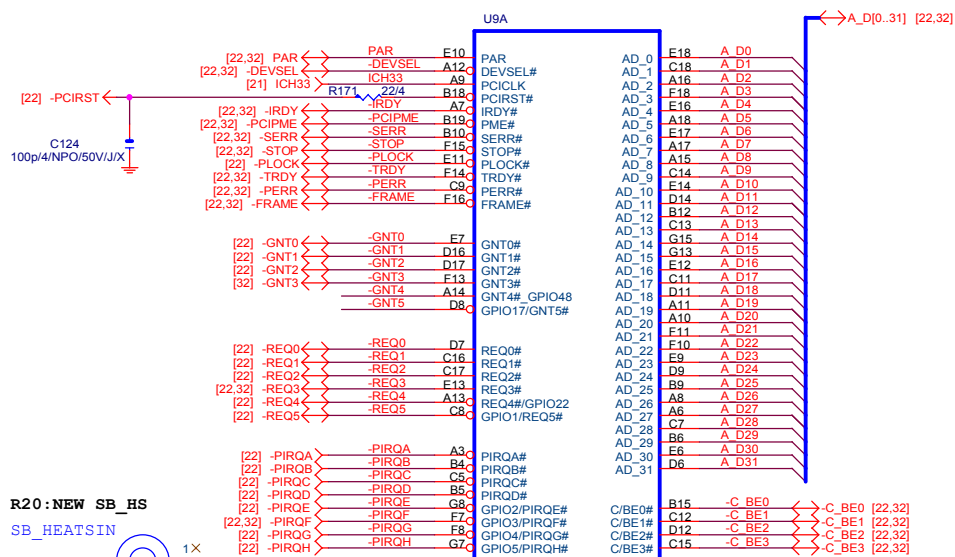

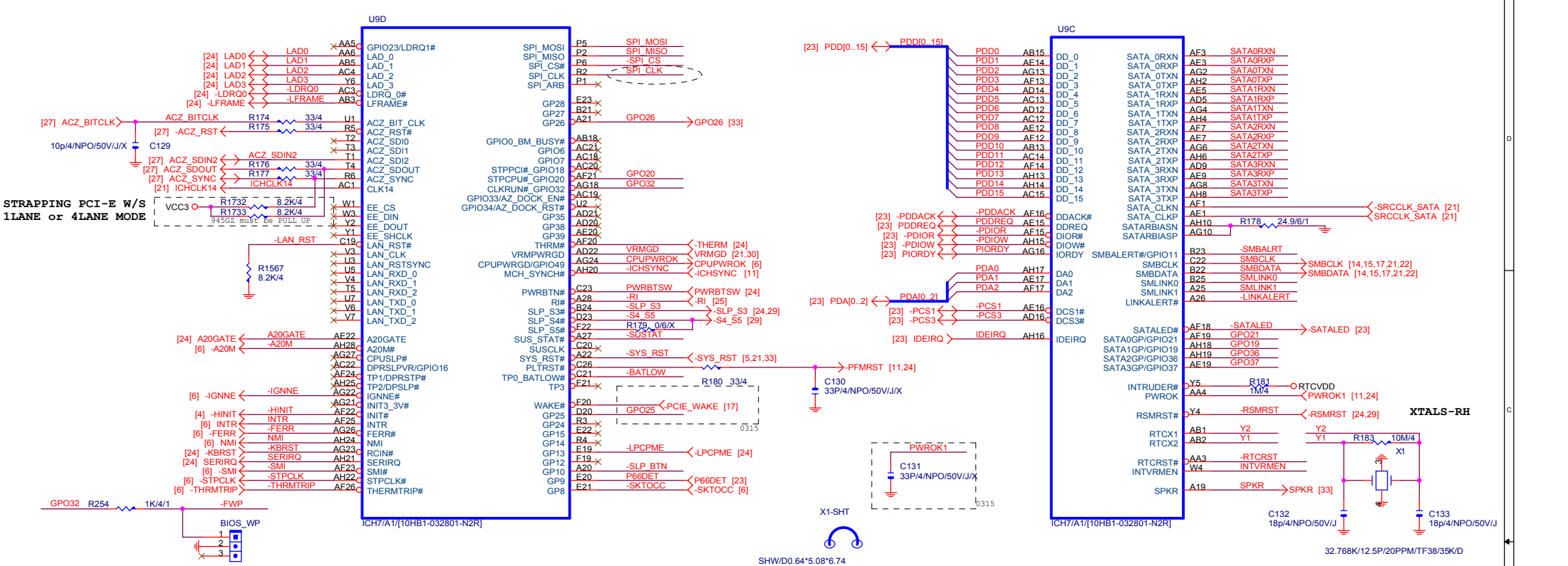

U9F		
A4	VSS1	R14
A23	VSS2	R15
B1	VSS3	R16
B8	VSS4	R17
B11	VSS5	R18
B14	VSS6	T6
B17	VSS7	T12
B20	VSS8	T13
B26	VSS9	T14
B28	VSS10	T15
C2	VSS11	T16
C6	VSS12	T17
D10	VSS13	U4
D13	VSS14	U12
D18	VSS15	U13
D21	VSS16	U14
D24	VSS17	U15
E1	VSS18	U16
E2	VSS19	U17
E8	VSS20	U24
E15	VSS21	U25
F3	VSS22	U26
F4	VSS23	V2
F12	VSS24	V15
F27	VSS25	V24
F28	VSS27	V27
G1	VSS28	V28
G2	VSS29	W6
G5	VSS30	W24
G6	VSS31	W25
G9	VSS32	W26
G14	VSS33	Y3
G18	VSS34	Y24
G21	VSS35	Y27
G24	VSS36	Y28
G25	VSS37	AA1
G26	VSS38	AA24
H3	VSS39	AA25
H4	VSS40	AA26
H5	VSS41	AB4
H24	VSS42	AB6
H27	VSS43	AB11
H28	VSS44	AB14
J1	VSS45	AB16
J2	VSS46	AB19
J5	VSS47	AB21
J24	VSS48	AB24
J25	VSS49	AB27
J26	VSS50	AB28
K24	VSS51	AC2
K27	VSS52	AC5
K28	VSS53	AC9
L13	VSS54	AC11
L15	VSS55	AD1
L24	VSS56	AD3
L25	VSS57	AD4
L26	VSS58	AD7
M3	VSS59	AD8
M4	VSS60	AD15
M5	VSS61	AD19
M12	VSS62	AD23
M13	VSS63	AE2
M14	VSS64	AE4
M15	VSS65	AE8
M16	VSS66	AE11
M17	VSS67	AE13
M24	VSS68	AE18
M27	VSS69	AE21
M28	VSS70	AE24
N1	VSS71	AE25
N2	VSS72	AF2
N5	VSS73	AF4
N6	VSS74	AF8
N11	VSS75	AF11
N12	VSS76	AF27
N13	VSS77	AF29
N14	VSS78	AG1
N15	VSS79	AG3
N16	VSS80	AG7
N17	VSS81	AG14
N18	VSS82	AG17
N24	VSS83	AG20
N26	VSS84	AG25
P3	VSS85	AH1
N25	VSS86	AH3
P4	VSS87	AH7
P12	VSS88	AH12
P13	VSS89	AH23
P14	VSS90	AH27
P15	VSS91	C27
P16	VSS92	E4
P17	VSS93	AG11
P24	VSS94	
P27	VSS95	
P28	VSS96	
R1	VSS97	
R11	VSS98	
R12	VSS99	
R13	VSS100	

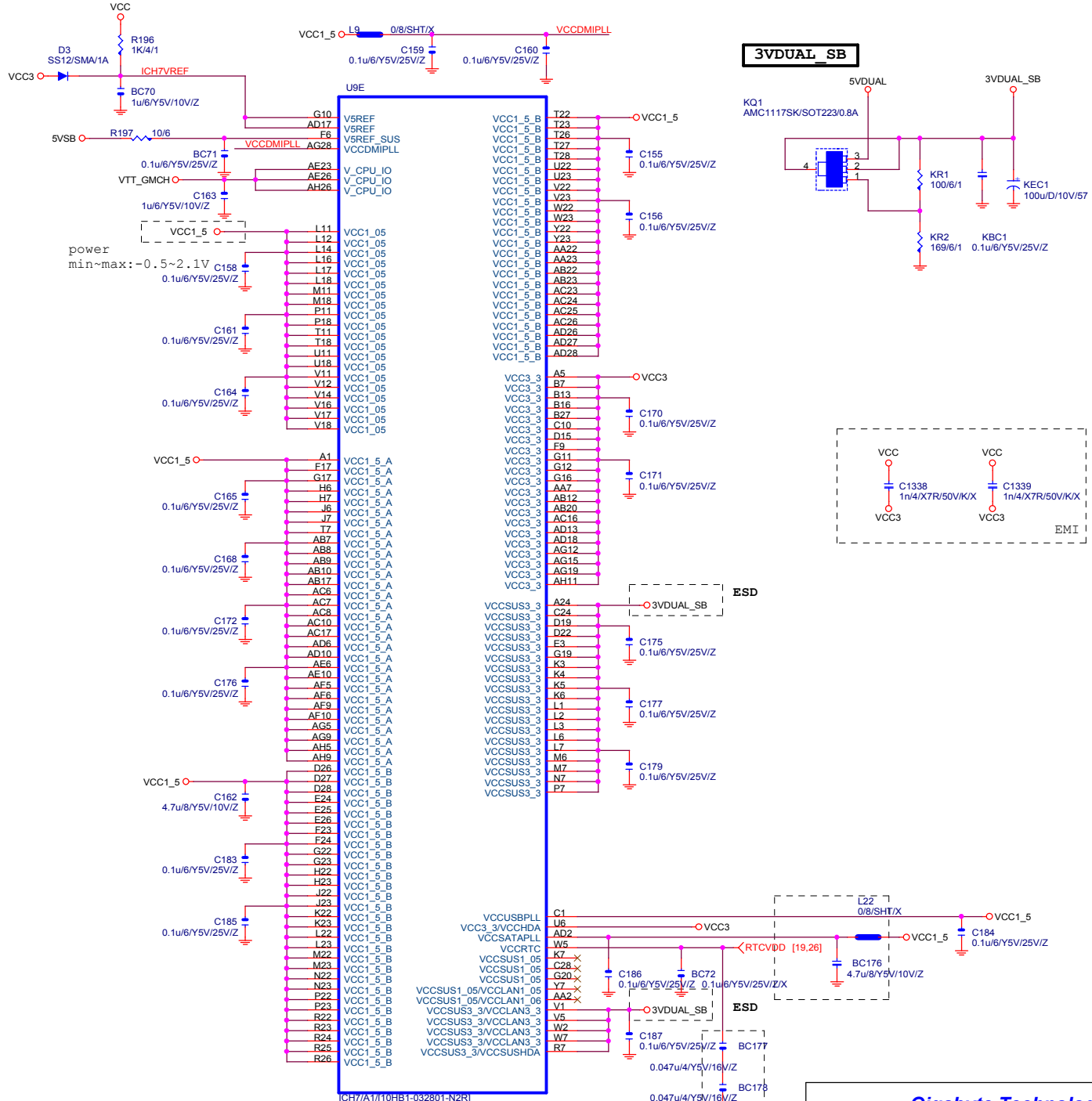

<b>Gigabyte Technology</b>		
<b>ICHT7-PWR &amp; GND</b>		
Size B	Document Number	Rev
	<b>945GZM-S2</b>	<b>3.0</b>
Date:	Tuesday, December 26, 2006	Sheet 20 of 33

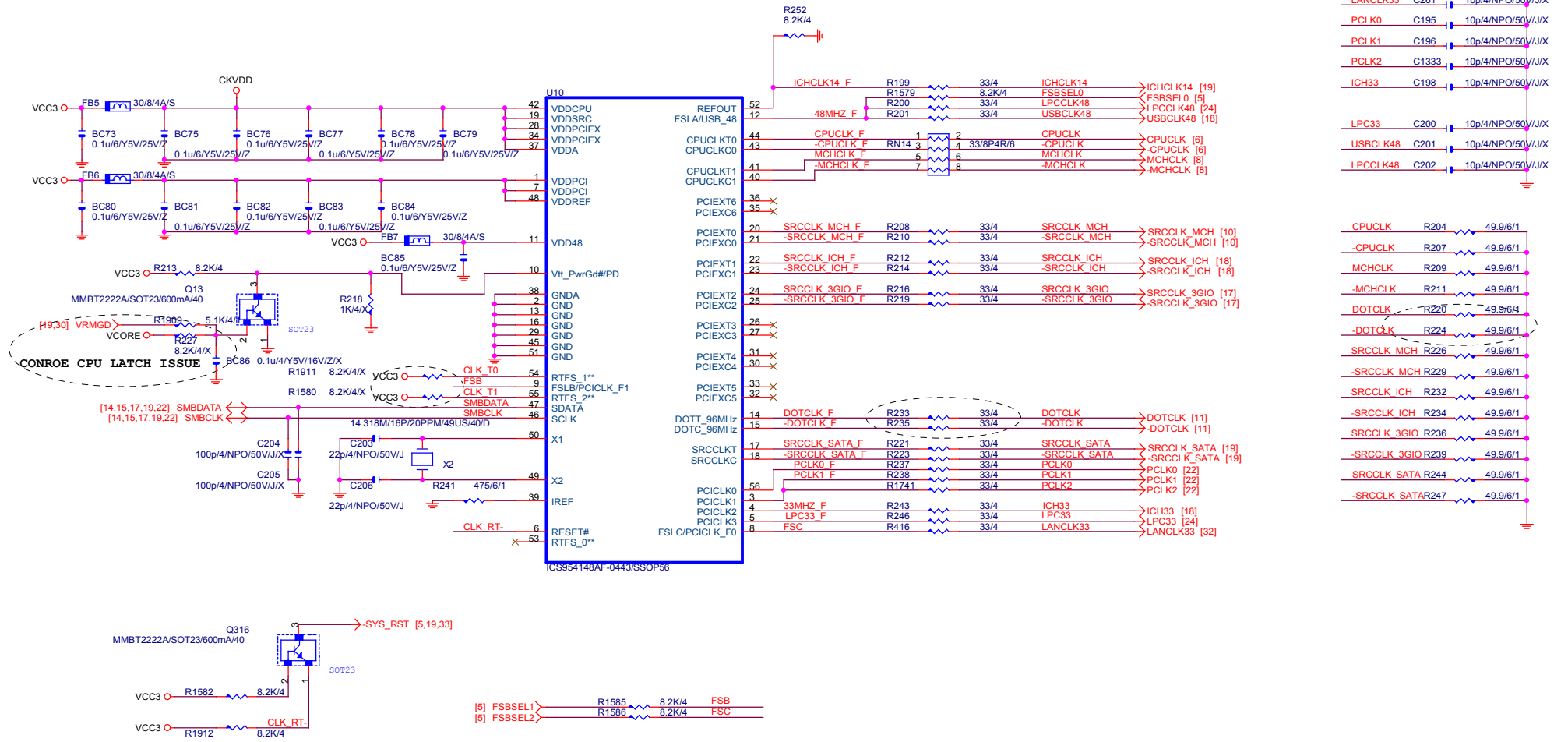

**PCI1, 2 SLOT**

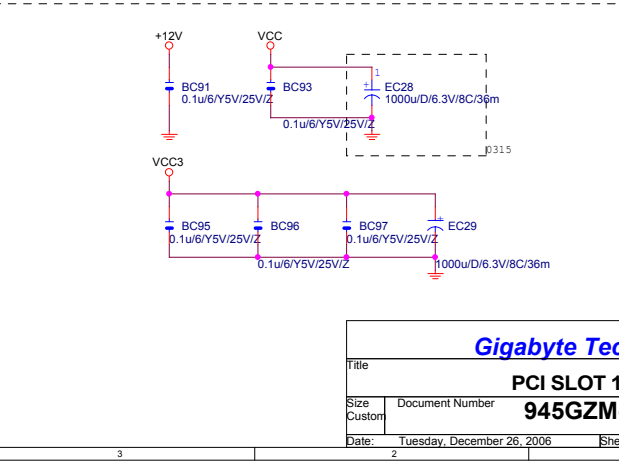
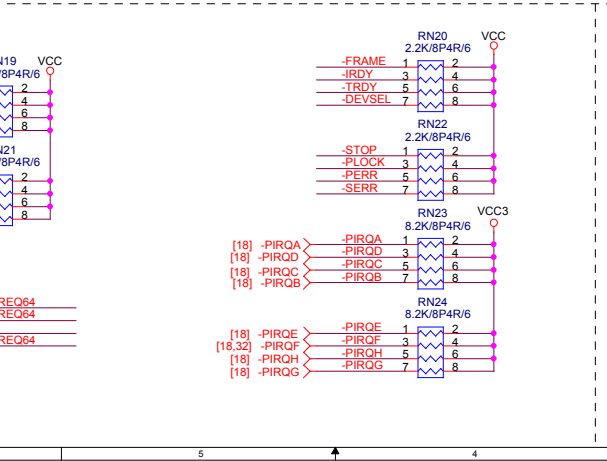
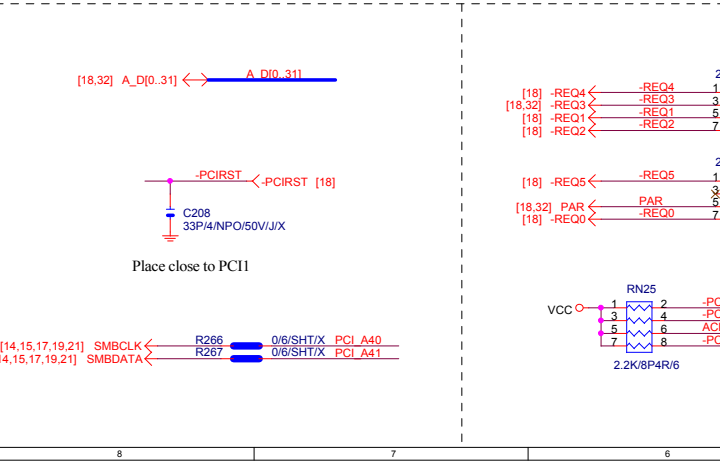
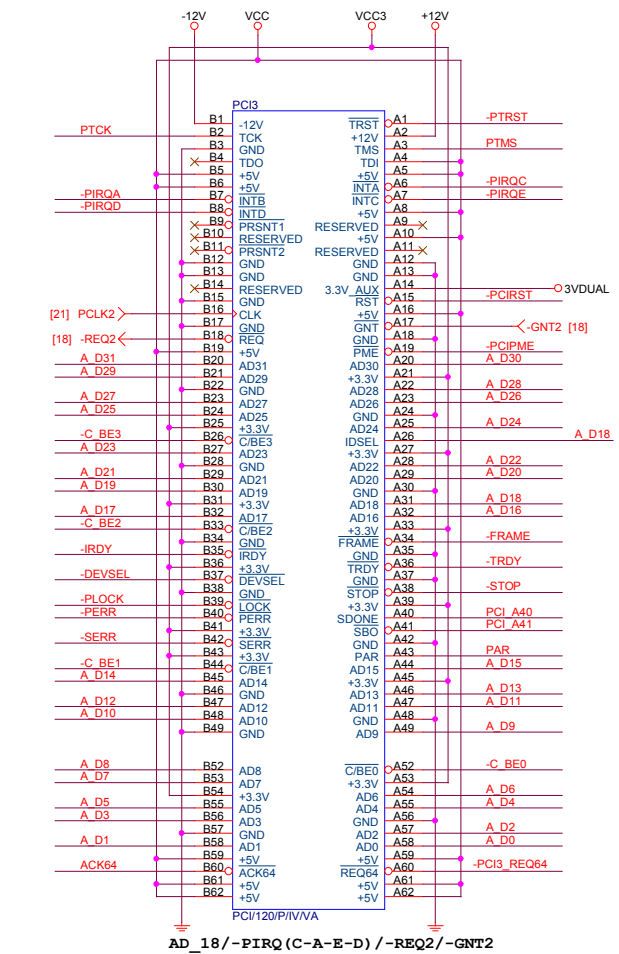
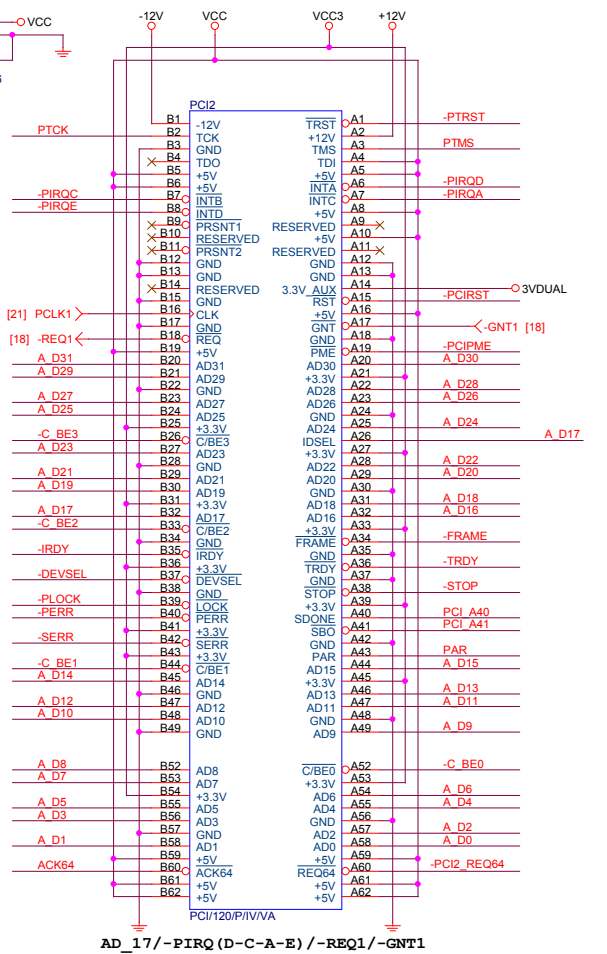
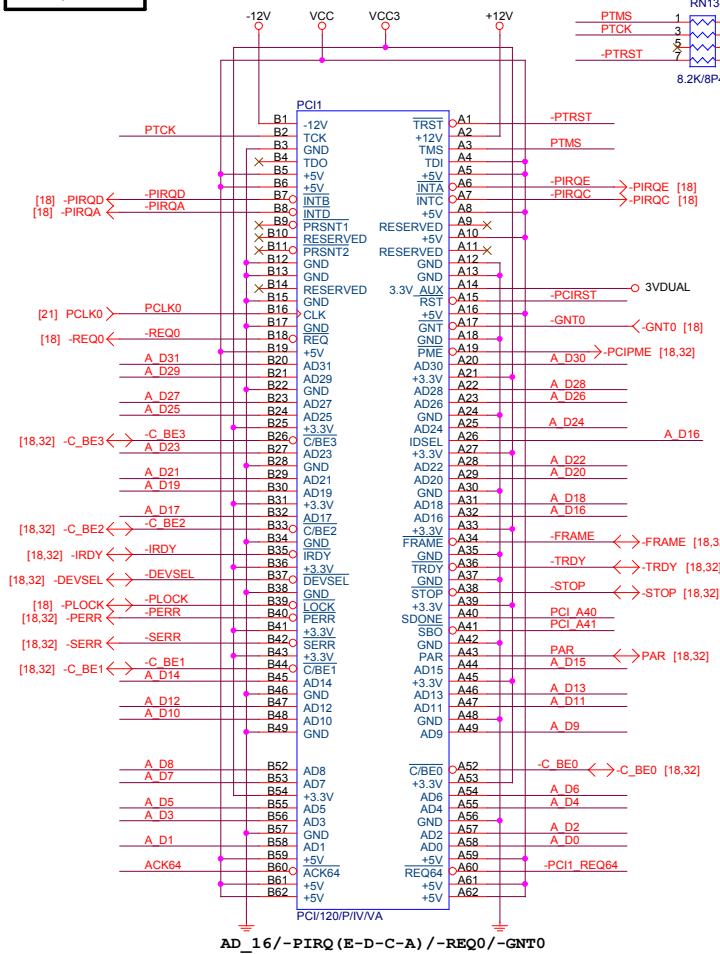

**Gigabyte Technology**

**PCI SLOT 1, 2/PCIEX1**

**945GZM-S2**

Title			Rev
Size	Document Number	<b>945GZM-S2</b>	3.0
Custom	Date:	Tuesday, December 26, 2006	Sheet 22 of 33

**IDE/SATA LED**

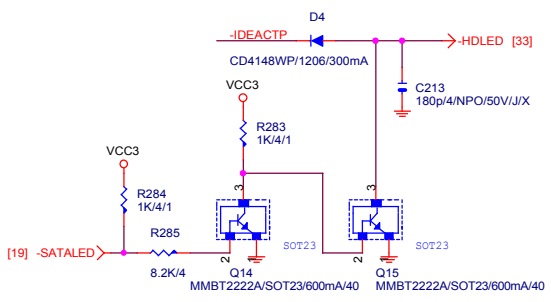

**IDE RESET**

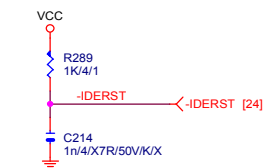

**FLOPPY**

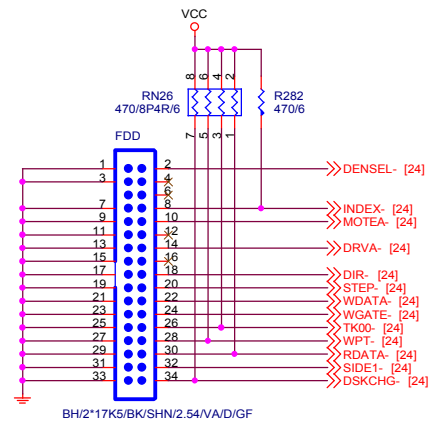

**IDE**

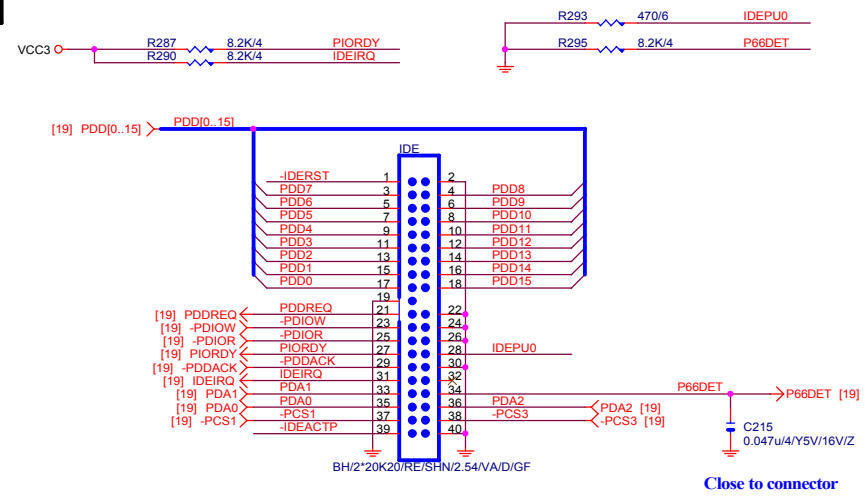

**FRONT USB1**

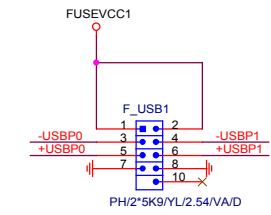
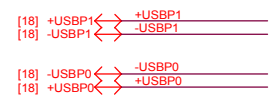

**FRONT USB2**

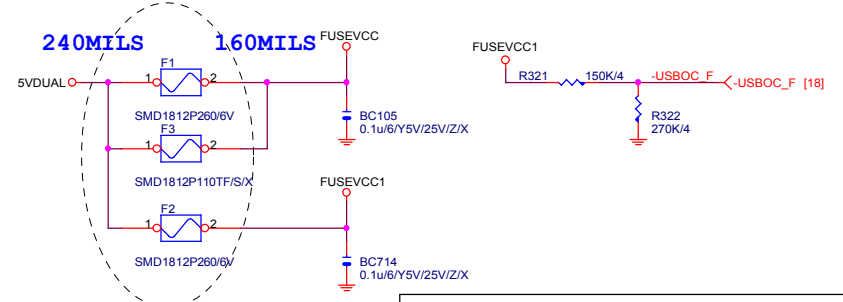
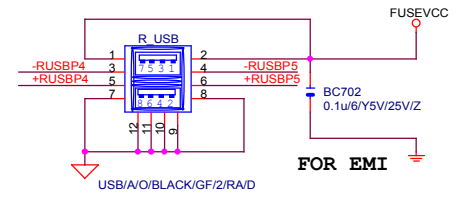
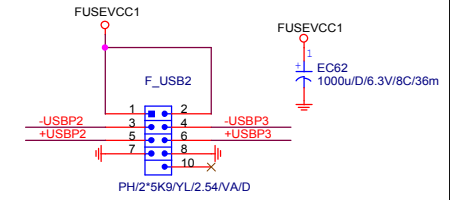

<b>Gigabyte Technology</b>		
<b>IDE,FDD,F_USB</b>		
Size B	Document Number	Rev
	<b>945GZM-S2</b>	<b>3.0</b>
Date:	Tuesday, December 26, 2006	Sheet 23 of 33

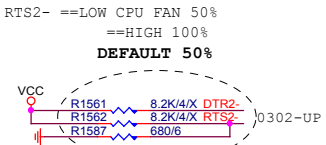

SOUT2	1	VID pins threshold voltage select: Vih / Vil : 2.0 / 0.8V
	0	VID pins threshold voltage select: Vih / Vil : 0.8 / 0.4V



- [25] DTR2- << 32
- [25] RTS2- << 33
- [25] DSR2 << 34
- [25] DSR2 << 35
- [25] TXD2 << 36
- [25] RXD2 << 37
- [33] FANIO1 << 38
- [33] FANPWM1 << 39
- [33] FANIO2 << 40
- [33] FANPWM3 << 41
- [30] IO\_VID5 << 42
- [30] IO\_VID4 << 43
- [30] IO\_VID3 << 44
- [30] IO\_VID2 << 45
- [30] IO\_VID1 << 46
- [30] IO\_VID0 << 47

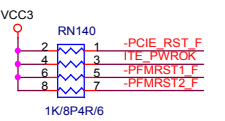
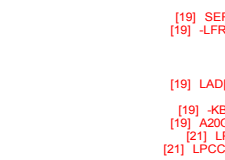
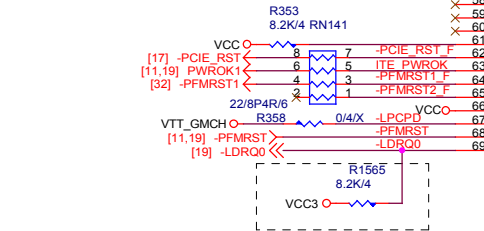

Dual BIOS:  
 GB logo :Pin 61 (GP15/CSA)  
 GB logo :Pin 59 (GP17/CSB)  
 Pin 59 Dual BIOS ,Power On Strapping:  
 H ==>Dual BIOS function Enable  
 L ==>Dual BIOS function Disable

1.2V or 3.3V tolerance select.  
 1.2V OUTPUT 接 VTT\_GMCH  
 3.3V OUTPUT 接 3.3V  
 LPCPD#=#VIDVCC

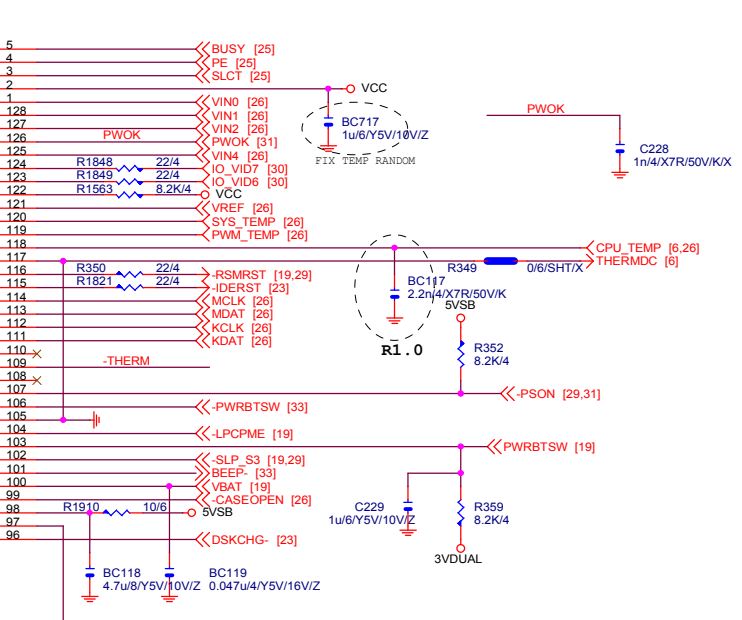
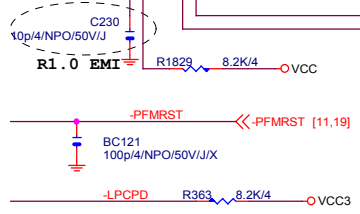
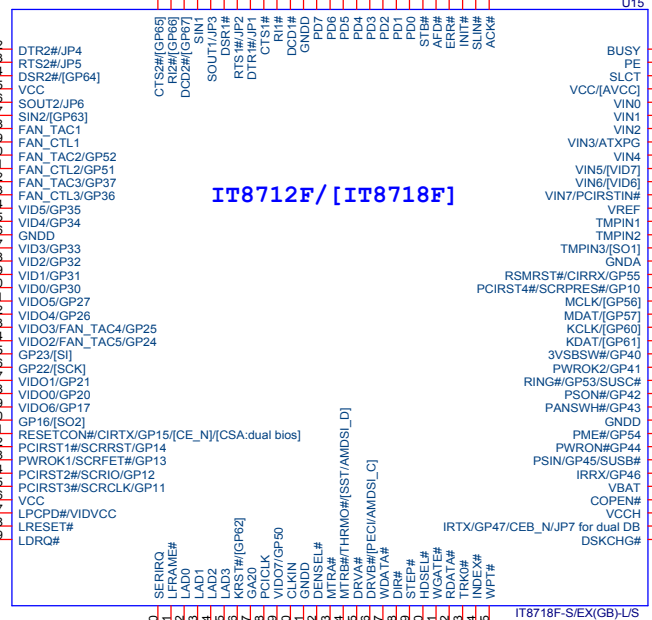
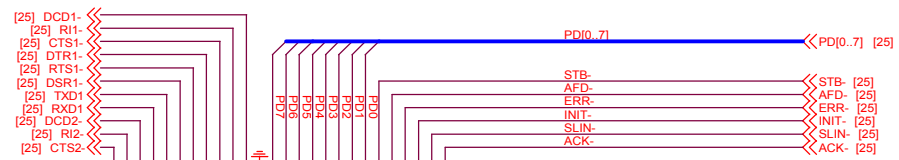

**JP7 : HIGH DUAL BIOS DISABLE  
 LOW DUAL BIOS ENABLE**

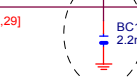
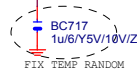
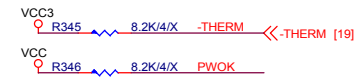

**Gigabyte Technology**

Title		
ITE 8718 LPC IO		
Size B	Document Number	Rev
	<b>945GZM-S2</b>	<b>3.0</b>
Date:	Tuesday, December 26, 2006	Sheet 24 of 33

**COMA**

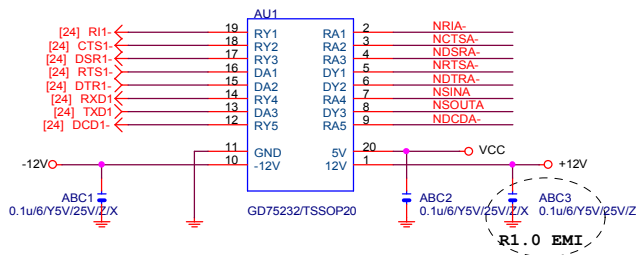

**RING IN**

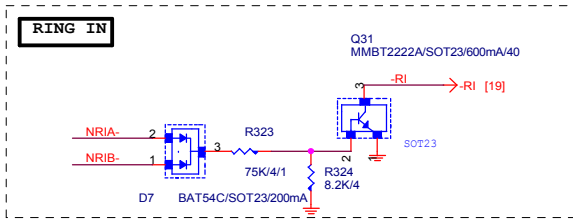

**EXTERNAL COMA**

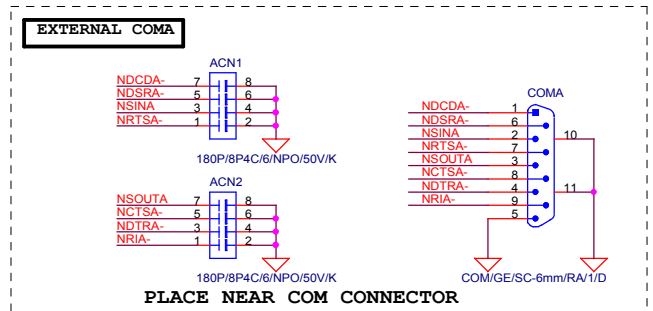

**COMB**

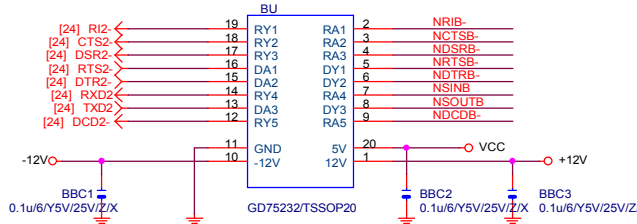

**INTERNAL COMB**

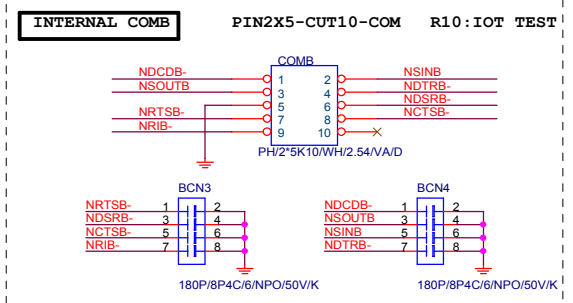

**LPT PORT**

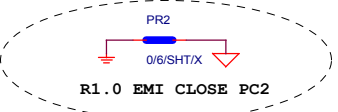
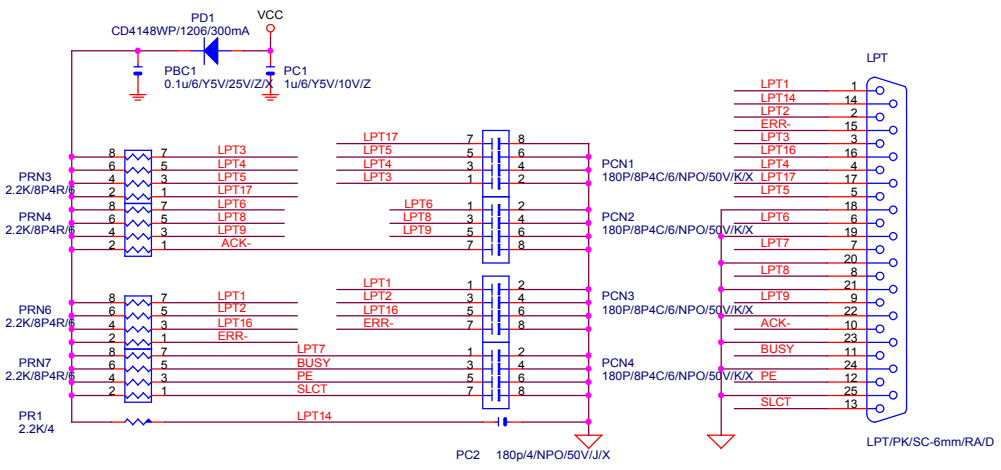
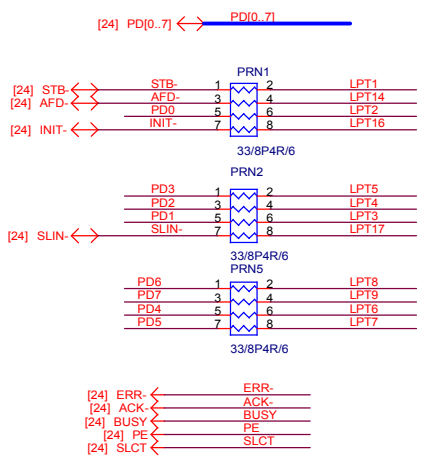

<b>Gigabyte Technology</b>		
<b>COM &amp; LPT PORT</b>		
Title	Document Number	Rev
	<b>945GZM-S2</b>	<b>3.0</b>
Date:	Tuesday, December 26, 2006	Sheet 25 of 33

**TEMP H/W MONITOR**

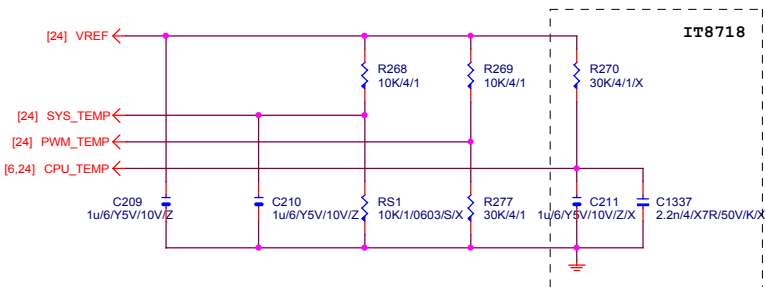

**VOLTAGE-- H/W MONITOR**

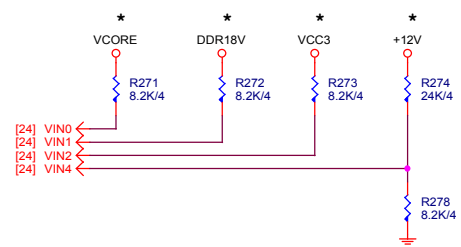

**CASE OPEN**

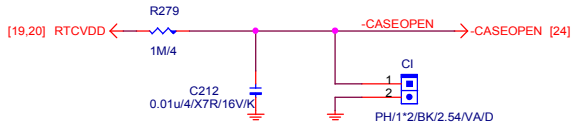

Case Open Circuits

**KB/MS**

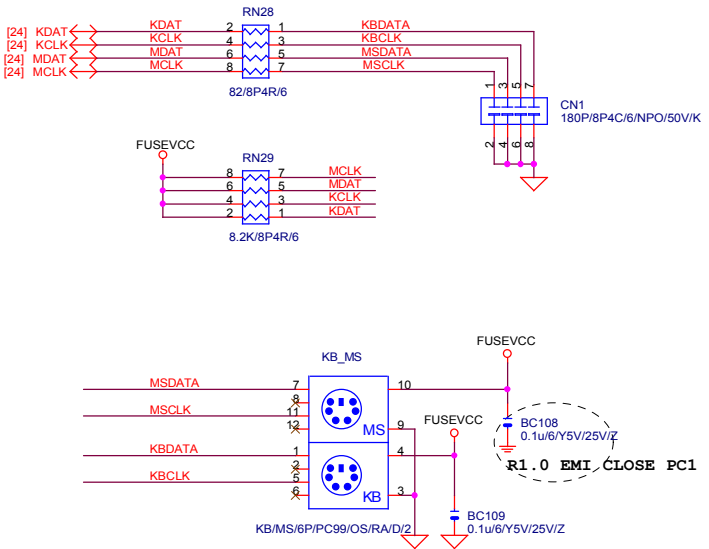

<b>Gigabyte Technology</b>		
<b>BIOS/HW-MONITOR/CI/KB/MS</b>		
Size B	Document Number	Rev
	<b>945GZM-S2</b>	<b>3.0</b>
Date:	Tuesday, December 26, 2006	Sheet 26 of 33

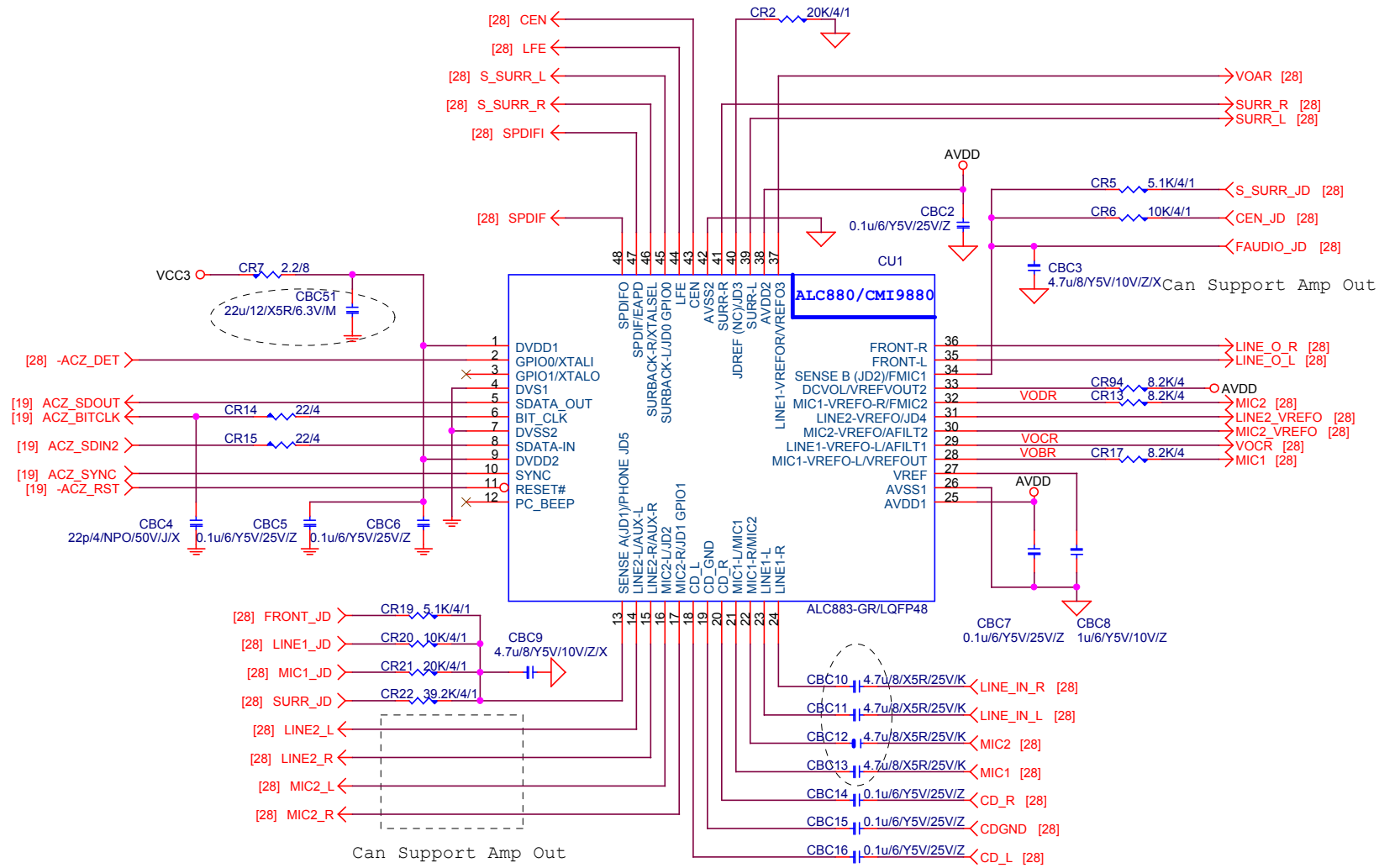

Gigabyte Technology

Title			AZALIA ALC883		
Size Custom	Document Number	945GZM-S2		Rev	3.0
Date:	Tuesday, December 26, 2006	Sheet	27	of	33

**CODEC POWER/EMI PAD**

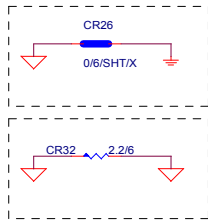
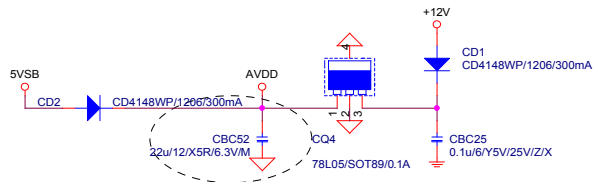

**CD IN**

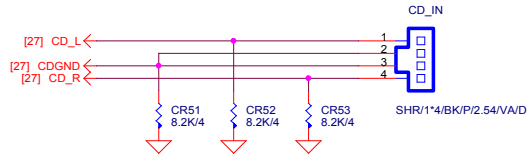

**SPDIF**

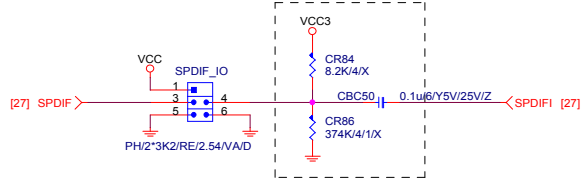

**AZALIA JACK**

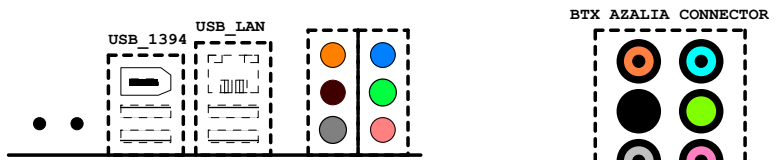

3RP/26P/OR, BK, GY, BU, GE, PK/RA/D/1/B  
VISTA規範: REAR-->BLK, CEN/SUB-->ORG

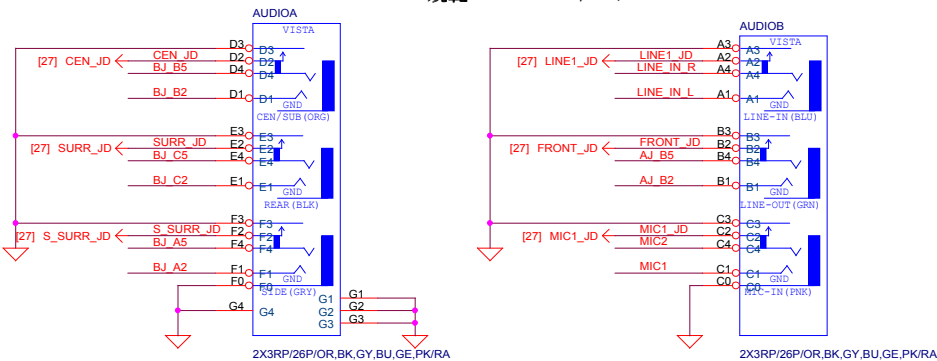

**LINE-OUT**

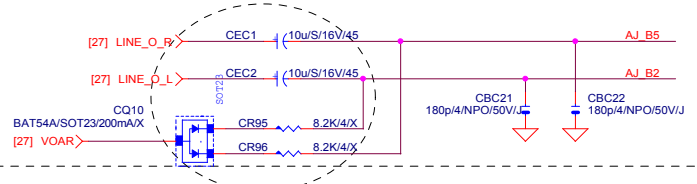

**LINE-IN**

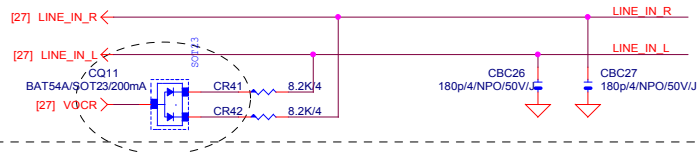

**MIC-IN**

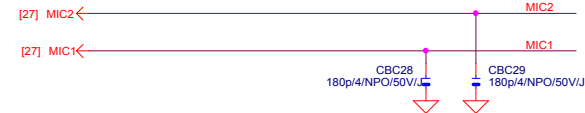

**SURROUND**

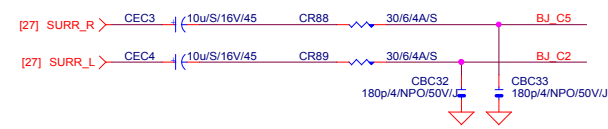

**CEN/LFE**

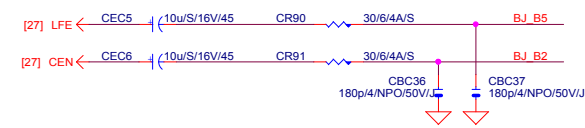

**SURRBACK**

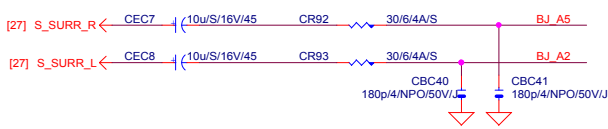

**AZALIA FRONT PANEL**

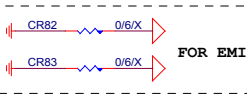
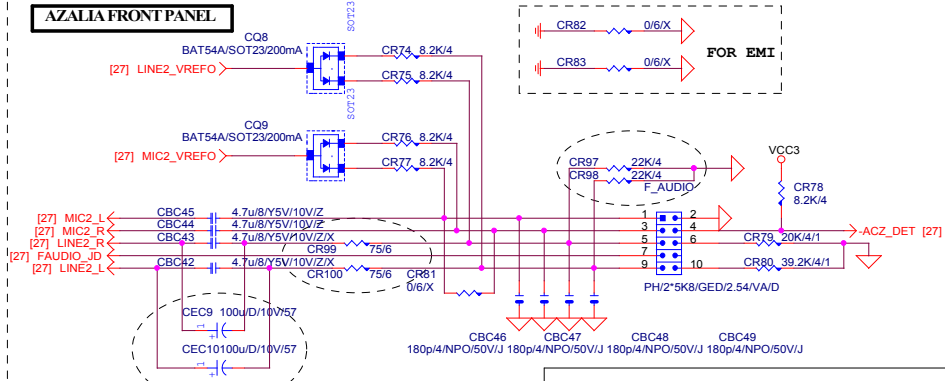

<b>Gigabyte Technology</b>			
<b>AUDIO JACK</b>			
Title		Rev <b>3.0</b>	
Size	Document Number	<b>945GZM-S2</b>	
Custom		Date: Tuesday, December 26, 2006	Sheet 28 of 33

**3VDUAL**

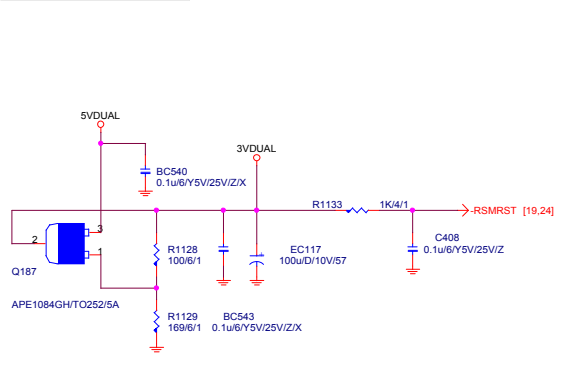

**DDRVTT**

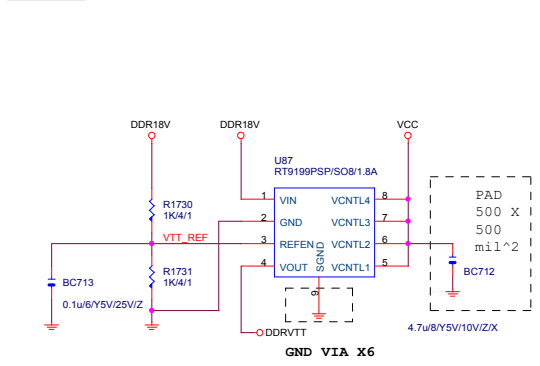

**5VDUAL**

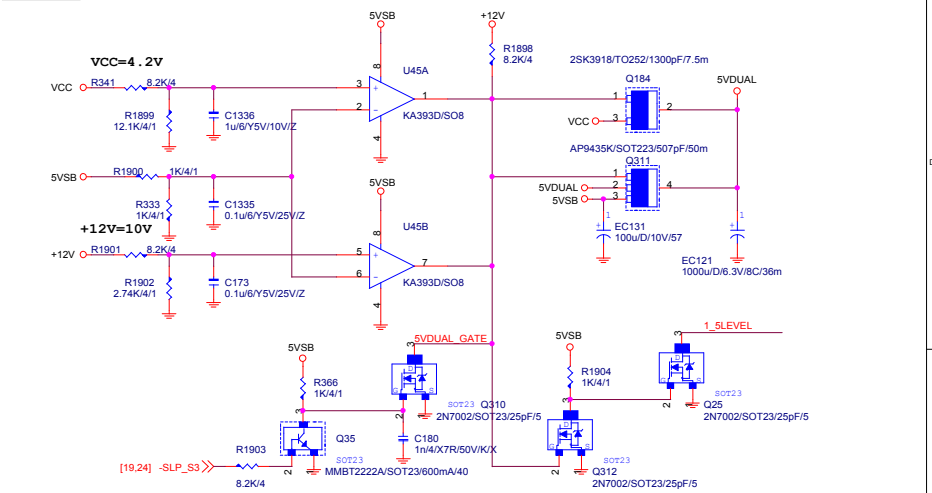

**DDR18V**

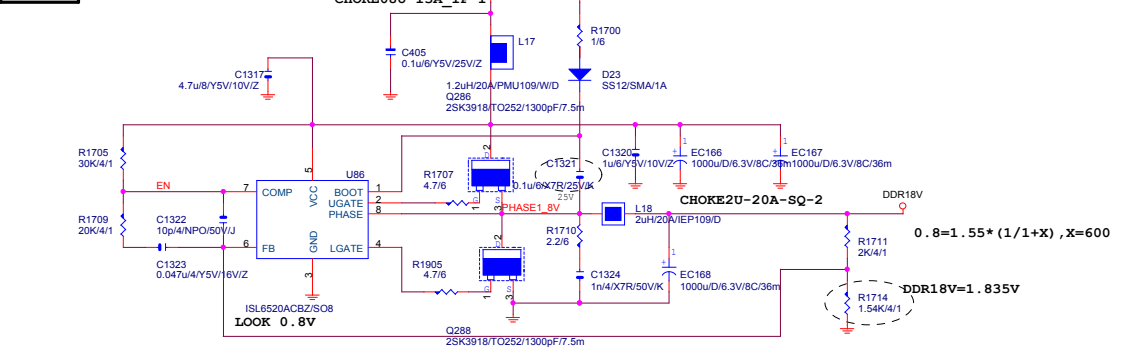

**POWER**

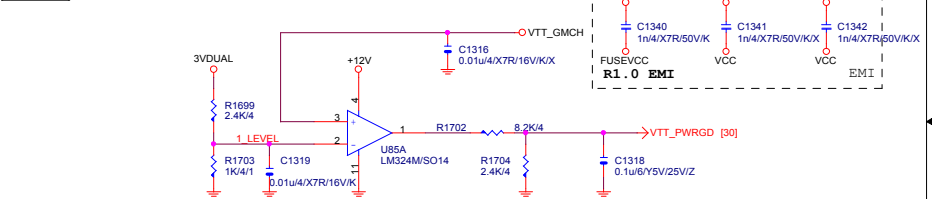

**POWER SEQUENCE**

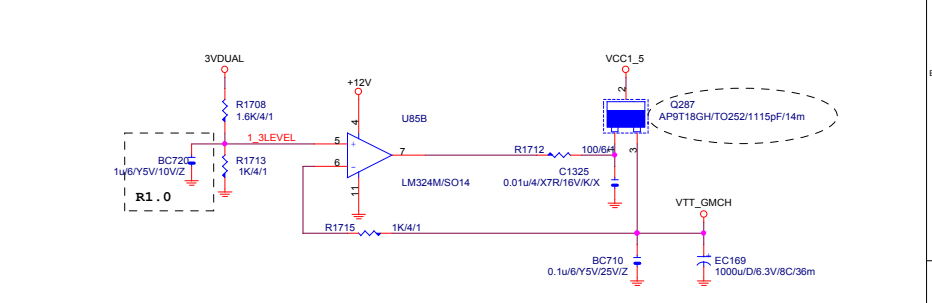
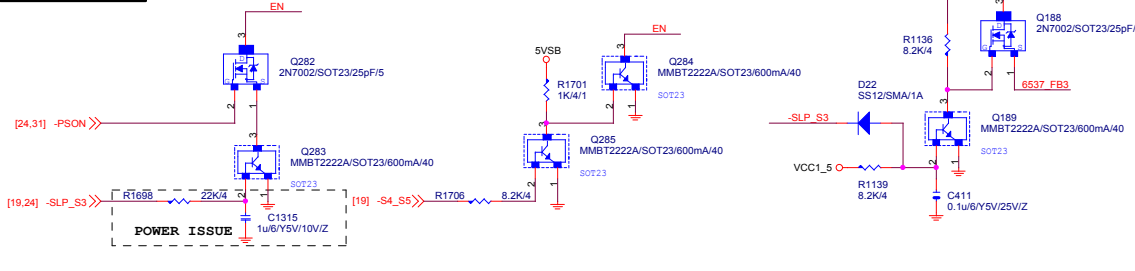

**FIX DATA-SW ISSUE**

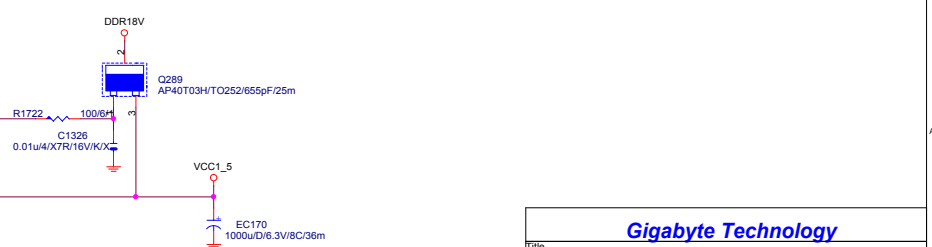
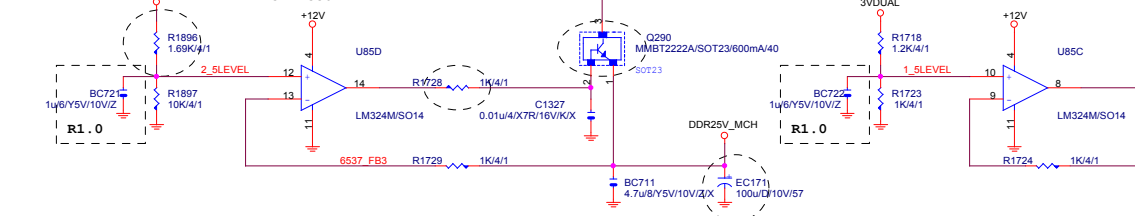

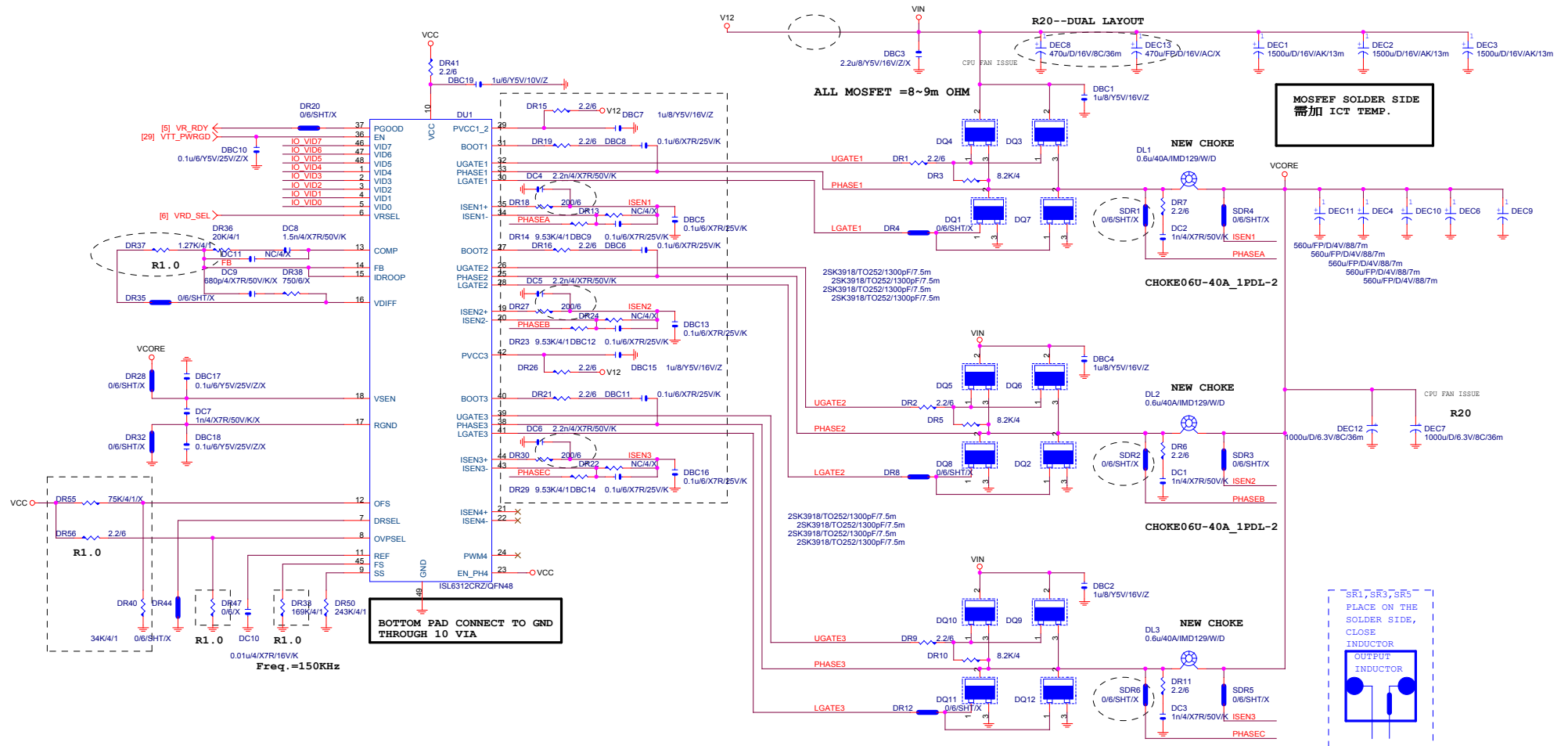

**MOSFET SOLDER SIDE  
帶加 ICT TEMP.**

**BOTTOM PAD CONNECT TO GND  
THROUGH 10 VIA**

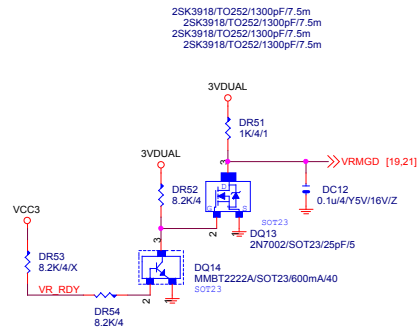
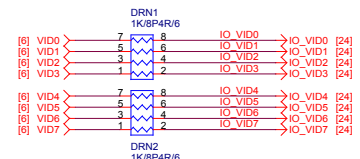
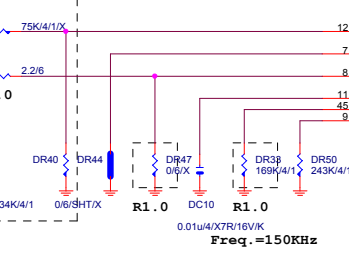
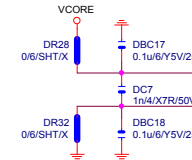
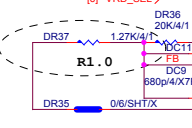
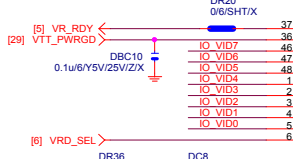
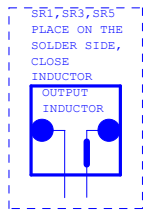

ATXPWR\_24-2  
**ATX POWER CONNECTOR**

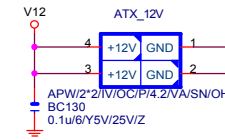
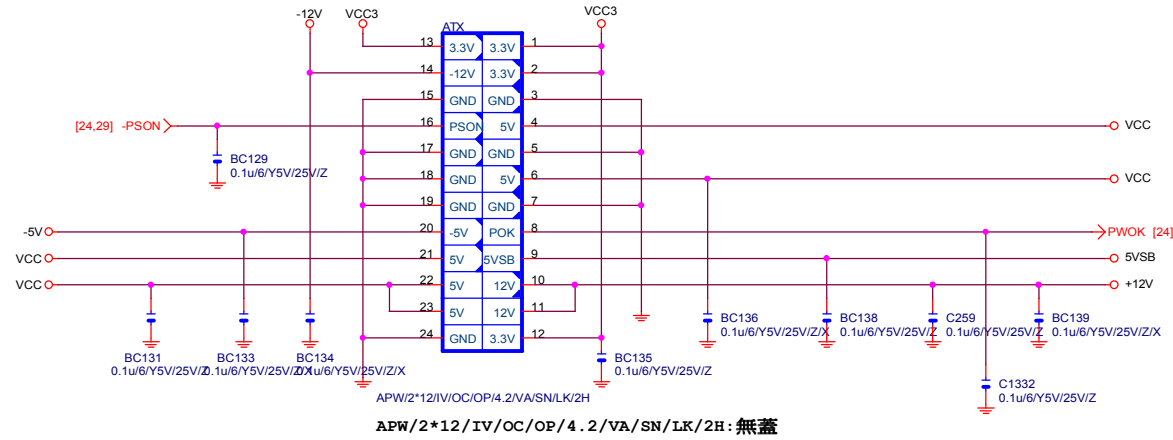

**HOLE\_3-RH-2**

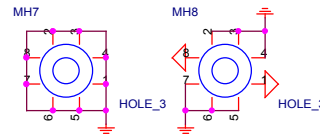
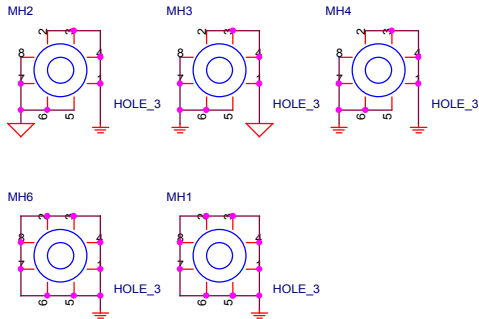

**HOLE\_3-RH-5MM**

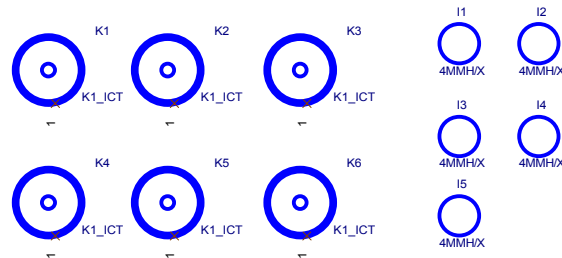

**Gigabyte Technology**

**ATX POWER CONNECTOR**

Title	Document Number <b>945GZM-S2</b>		Rev <b>3.0</b>
Date: Tuesday, December 26, 2006	Sheet 31	of 33	



**CPU SMART FAN SMART FAN**

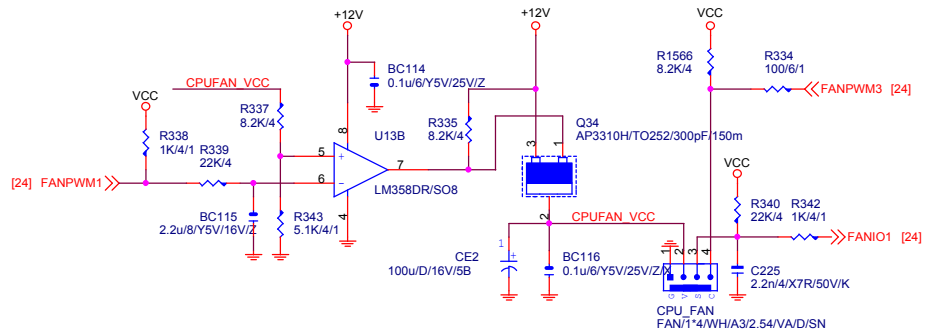

**PROCESSOR HOT**

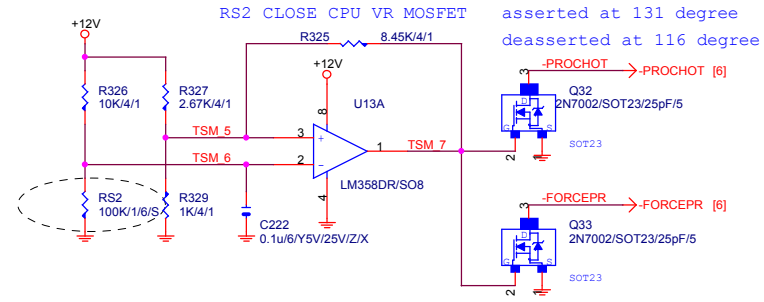

**INTEL FRONT PANEL**

MPD- : (GPIO25--VCCSUS3+HI+HI+DEFINED (C3/C4/S/1/S3/S/4/S5)) -->INTEL

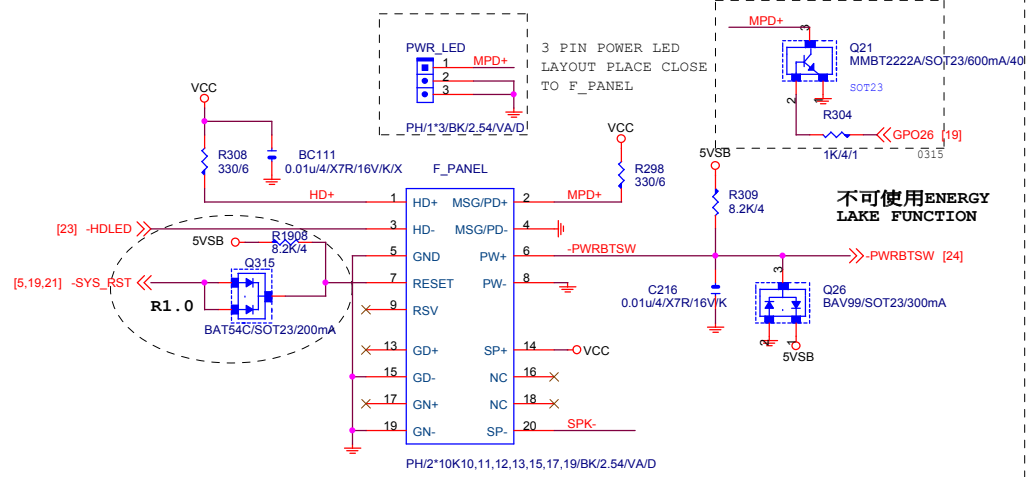

**SYS\_FAN**

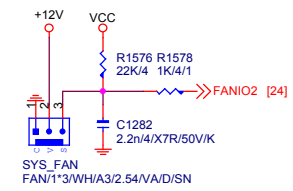

**BUZZER**

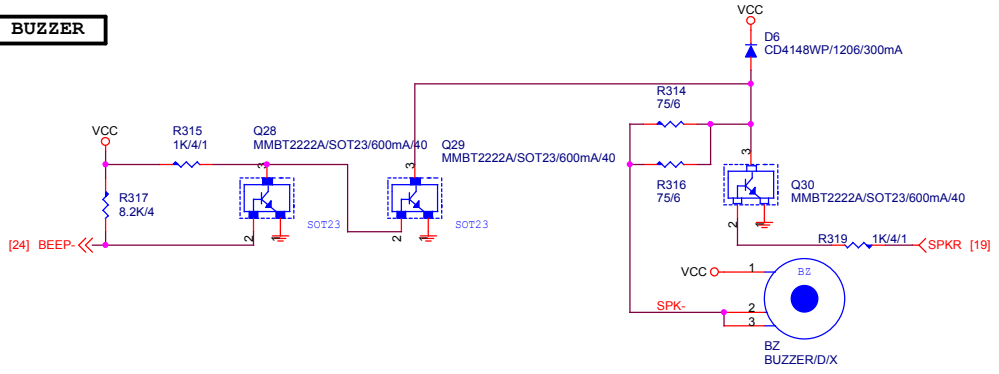

<b>Gigabyte Technology</b>			
<b>FRONT PANEL</b>			
<b>945GZM-S2</b>		Rev <b>3.0</b>	
Date:	Tuesday, December 26, 2006	Sheet	33 of 33