

BLOCK DIAGRAM

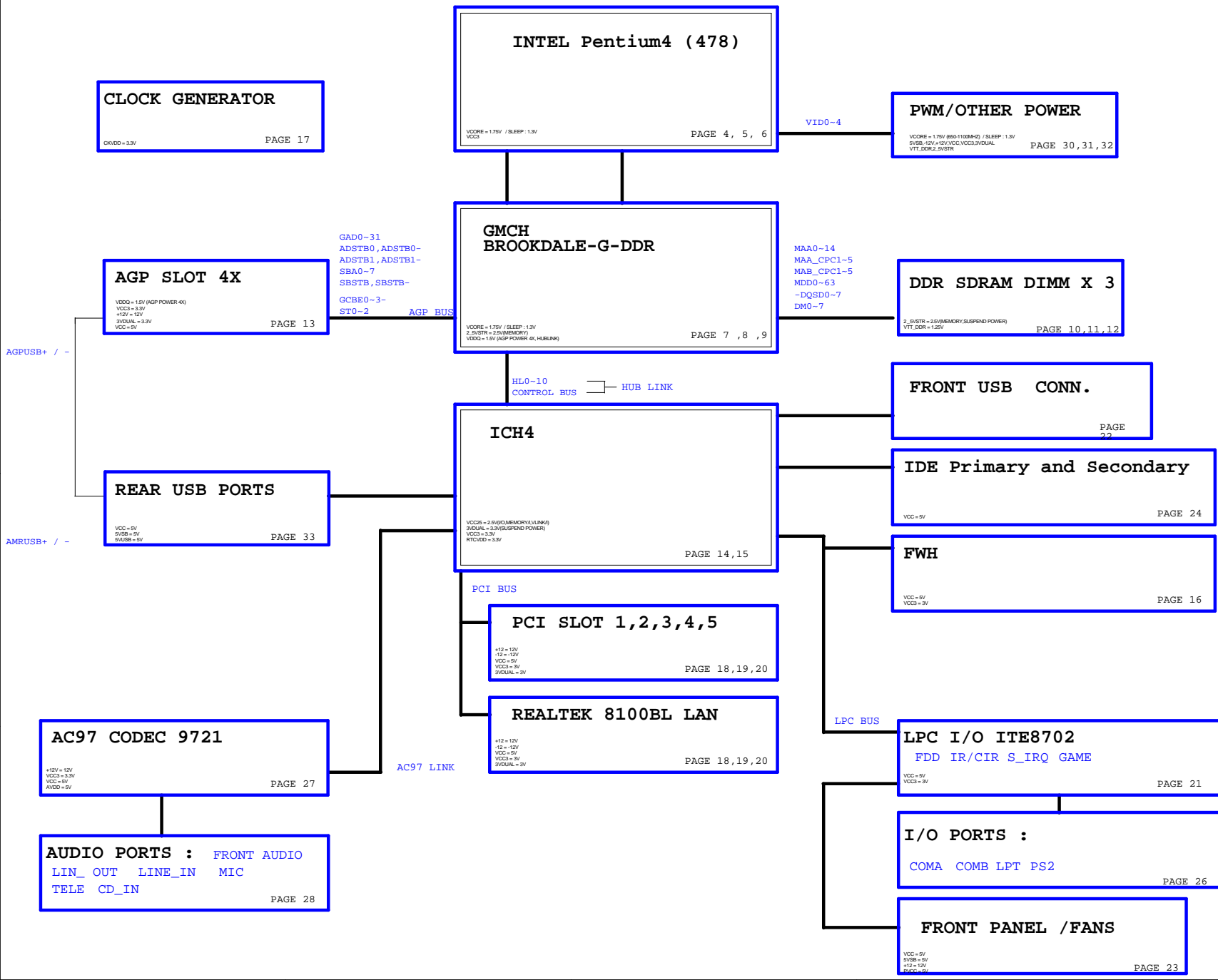

GIGABYTE		
BOM & PCB MODIFY HISTORY		
File	Document Number	Rev
GA-8PE800	GA-8PE800	1.1
Date	Wednesday, March 05, 2003	Print 3 of 35

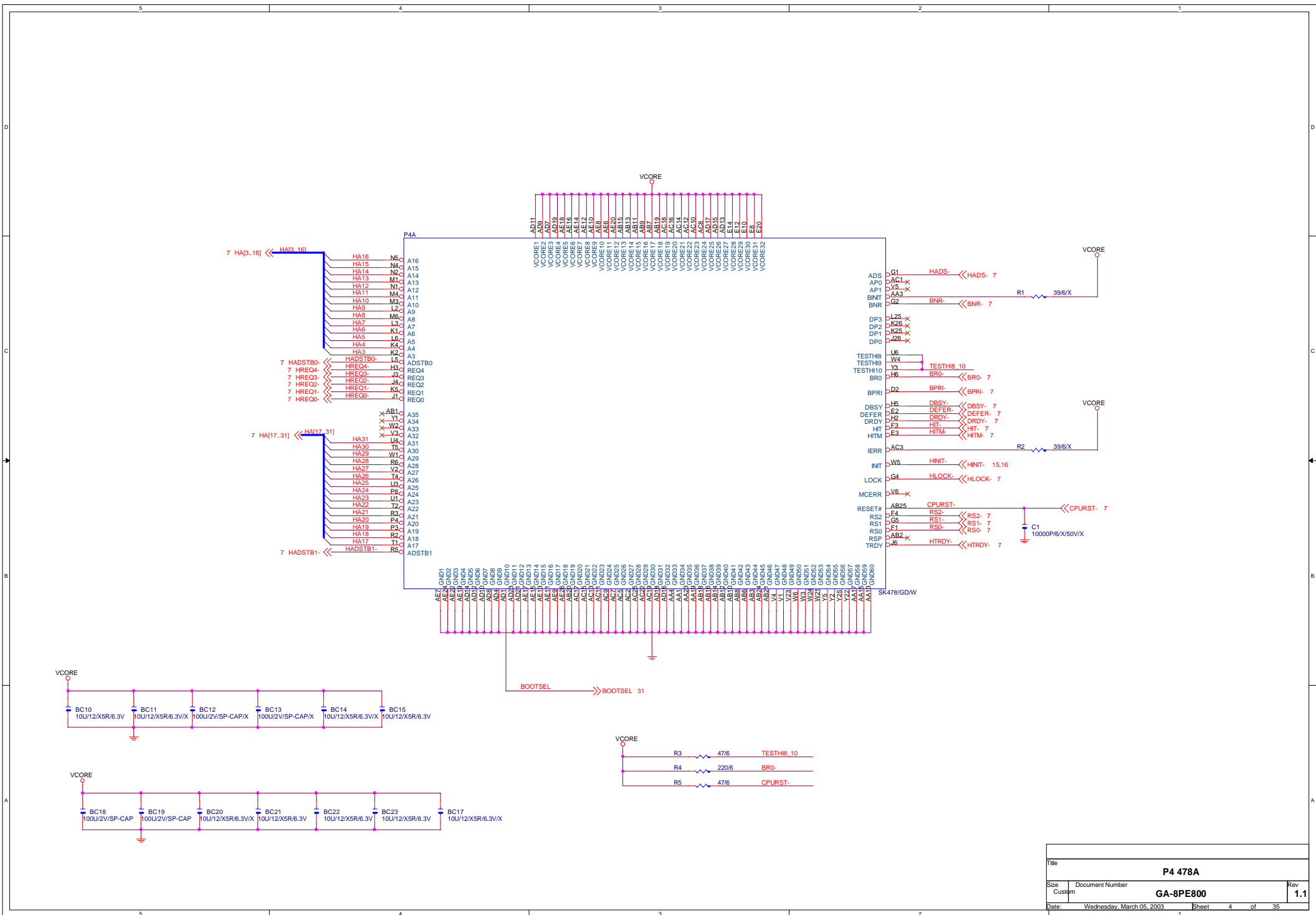

Title		
P4 478A		
Size	Document Number	Rev
Custom	GA-8PE800	1.1
Date:	Wednesday, March 05, 2003	Sheet 4 of 35

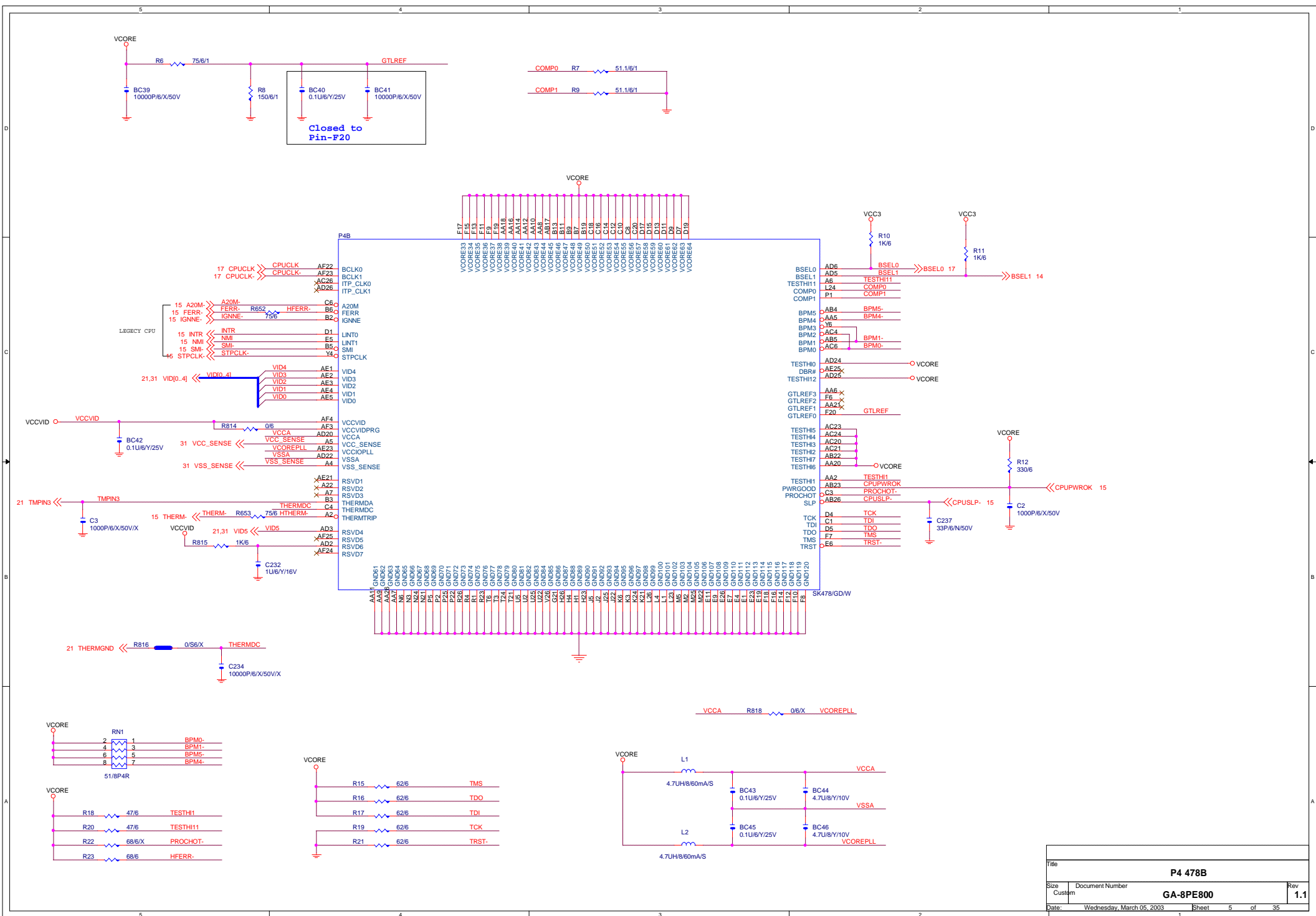

Title			P4 478B		
Size	Document Number				Rev
Custom	GA-8PE800				1.1
Date:	Wednesday, March 05, 2003		Sheet	5	of 35

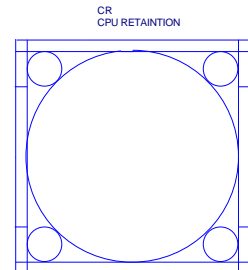
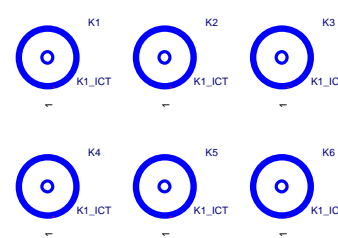
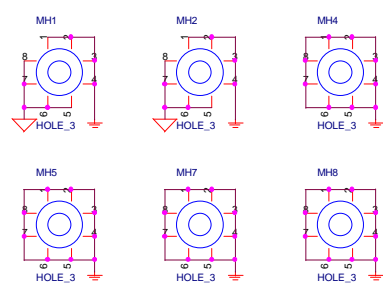
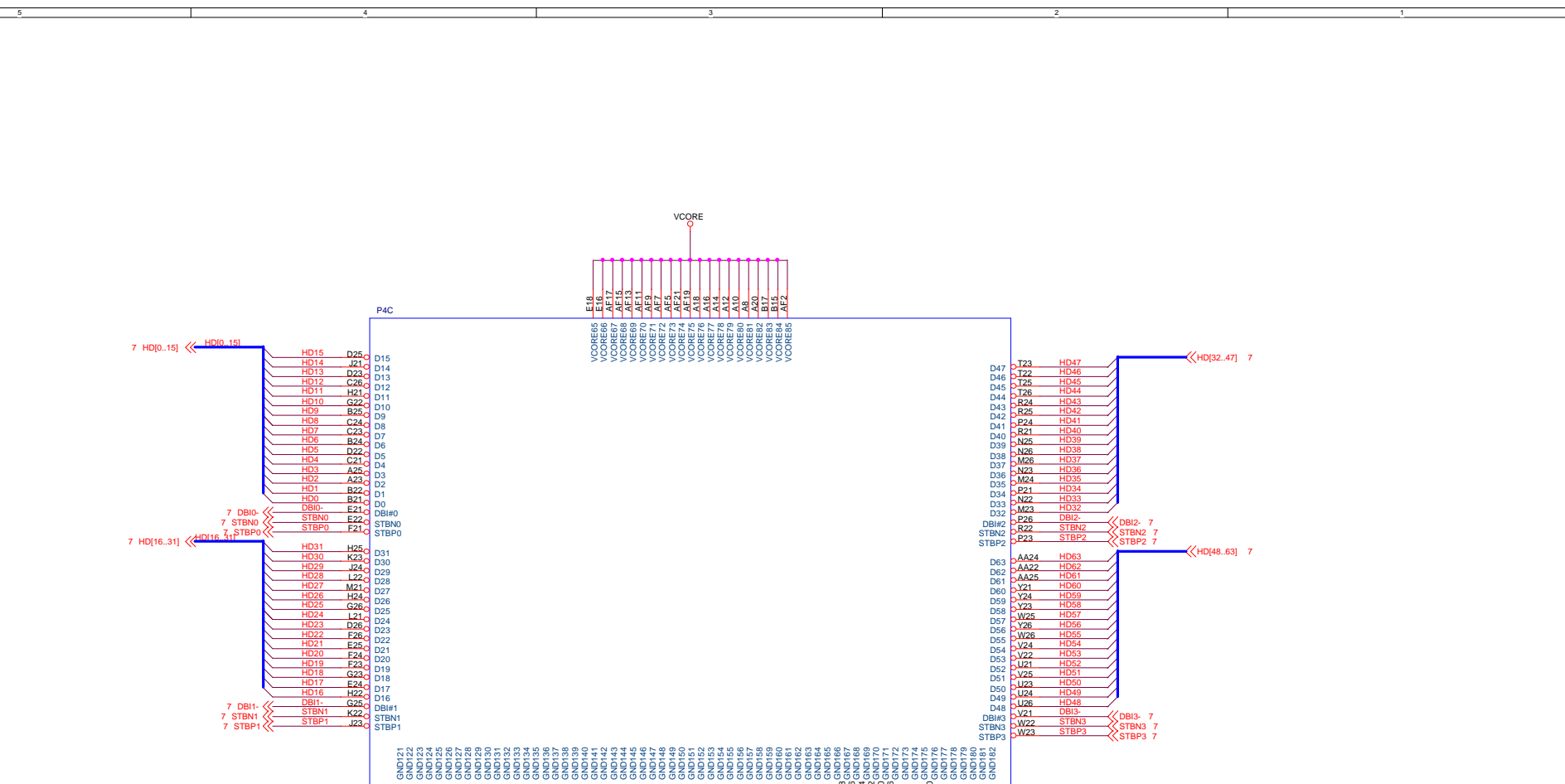

Title			P4 478C		
Size	Document Number				Rev
Custom	GA-8PE800				1.1
Date:	Wednesday, March 05, 2003	Sheet	6	of	35

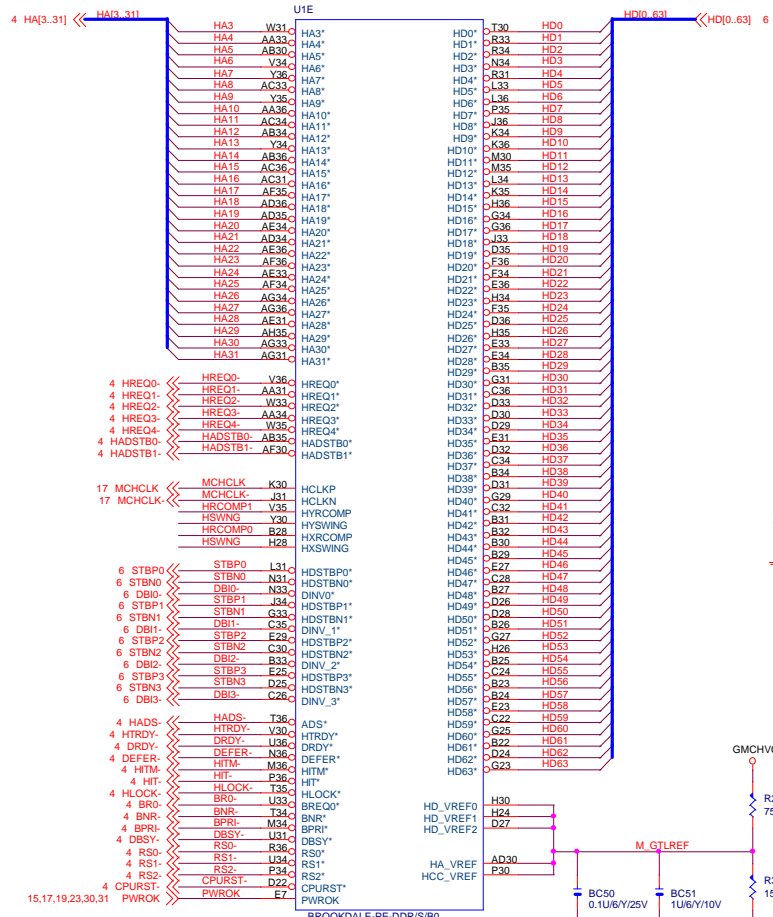

CPU INTERFACE

BROOKDALE-PE-DDR/SB0

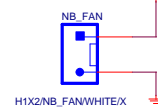
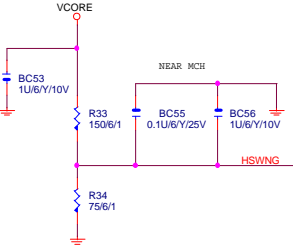

H1X2/NB_FANWHITEX

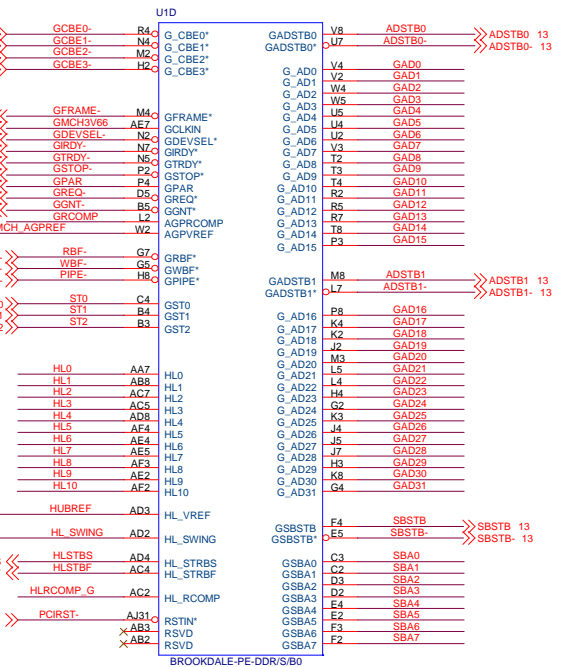
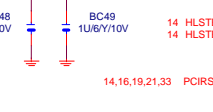
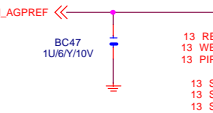

AGP INTERFACE

BROOKDALE-PE-DDR/SB0

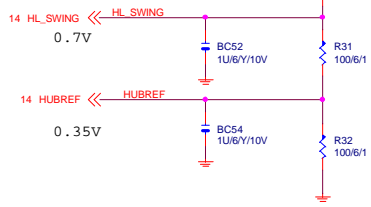

Title		
BROOKDALE-G_A		
Size	Document Number	Rev
Custom	GA-8PE800	1.1
Date:	Wednesday, March 05, 2003	Sheet 7 of 35

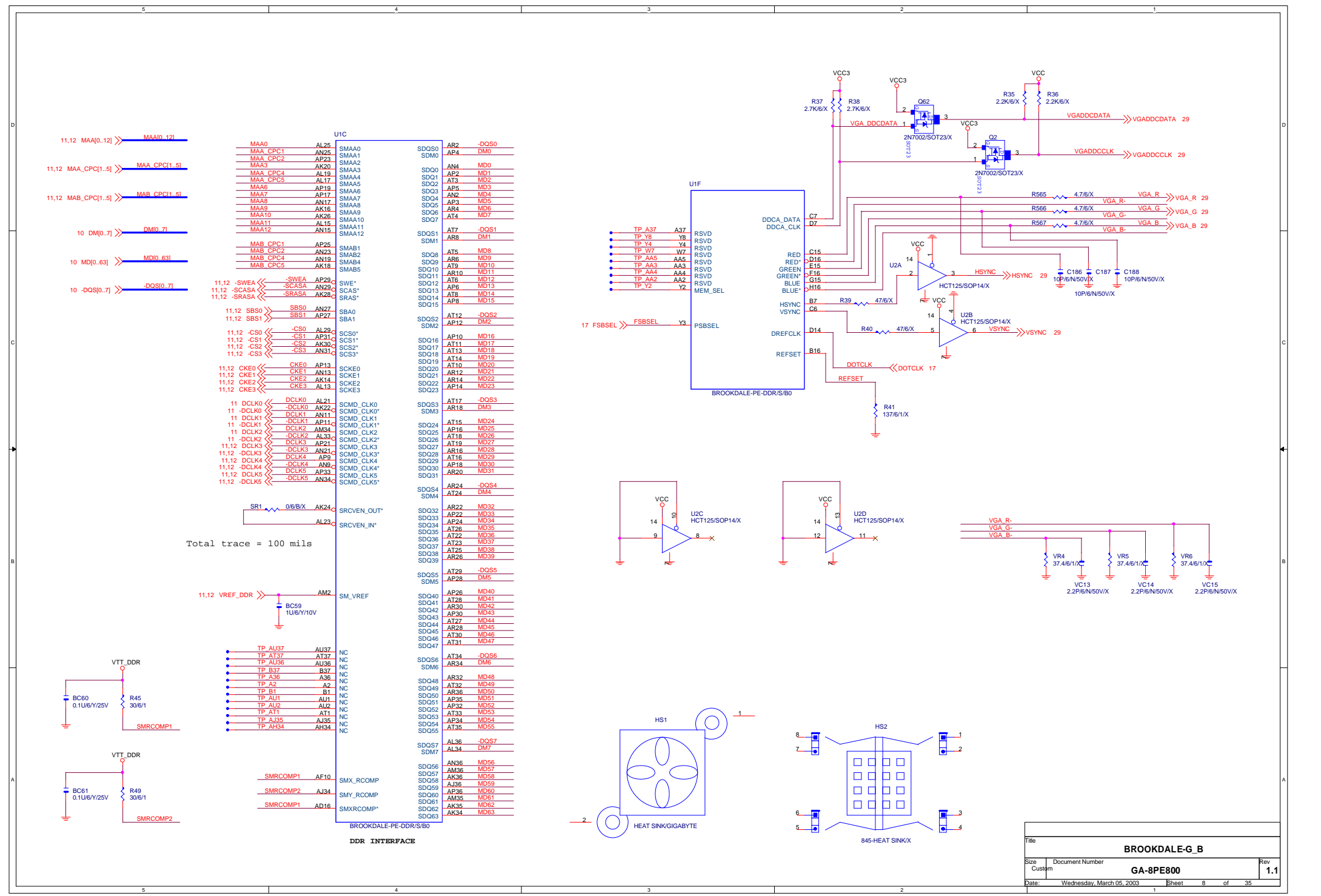

Title			BROOKDALE-G_B		
Size			Custom		
Document Number			GA-8PE800		
Date			Wednesday, March 05, 2003		
Sheet			8 of 35		
Rev			1.1		

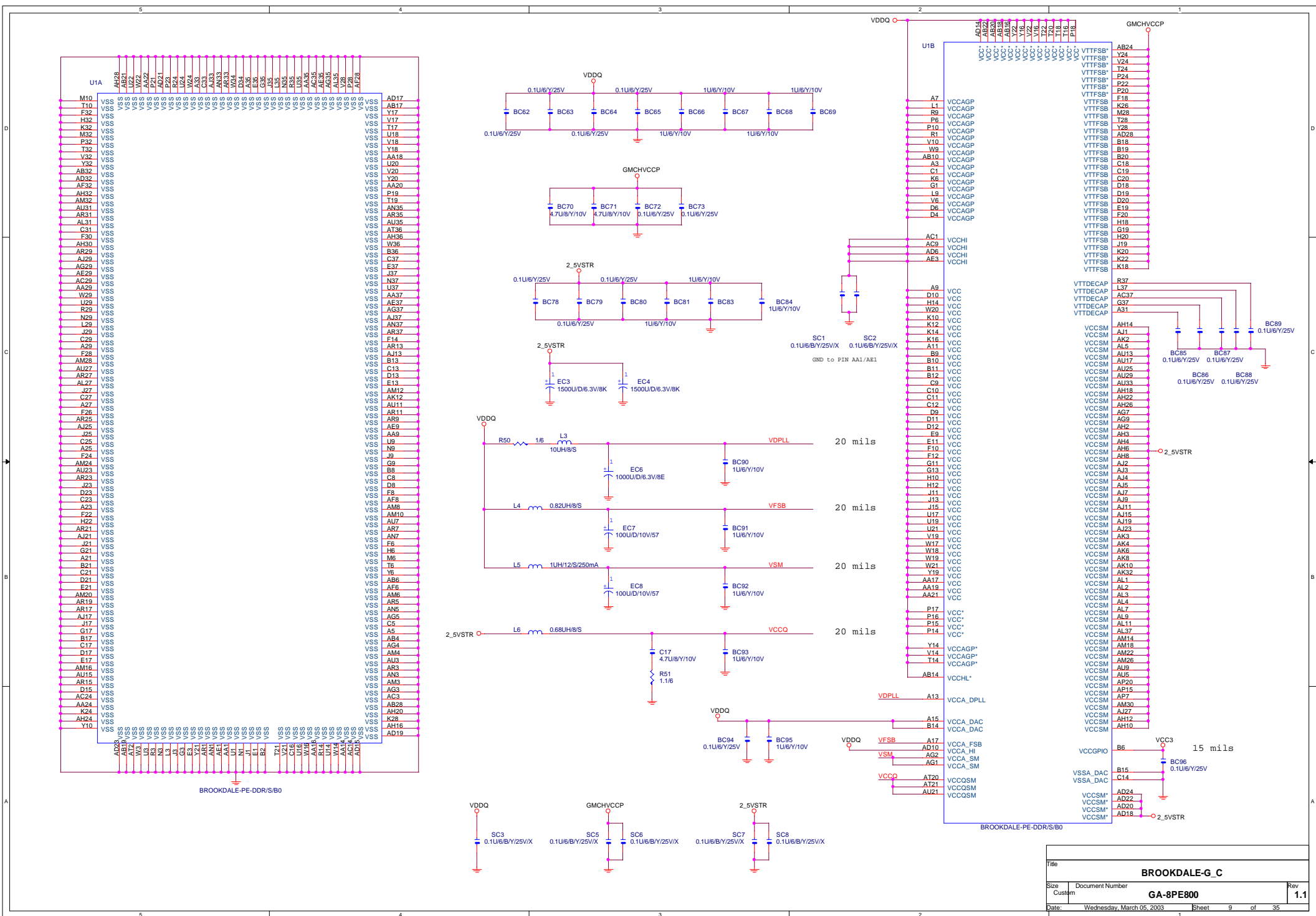

Title		
BROOKDALE-G_C		
Size	Document Number	Rev
Custom	GA-8PE800	1.1
Date:	Wednesday, March 05, 2003	Sheet 9 of 35

11,12 MD_[0..63] << <<MD[0..63] 8

11,12 DM_[0..7] >> >>DM[0..7] 8

11,12 -DQS_[0..7] << <<-DQS[0..7] 8

DM 0	RN3	1	2 10/8P4R	DM0
-DQS_0		3	4	-DQS0
MD 2		5	6	MD2
MD 6		7	8	MD6
MD 0	RN5	1	2 10/8P4R	MD0
MD 4		3	4	MD4
MD 5		5	6	MD5
MD 1		7	8	MD1
MD 12	RN6	1	2 10/8P4R	MD12
MD 13		3	4	MD13
-DQS_1		5	6	-DQS1
DM 1		7	8	DM1
MD 14	RN7	1	2 10/8P4R	MD14
MD 15		3	4	MD15
MD 10		5	6	MD10
MD 11		7	8	MD11
-DQS_2	RN9	1	2 10/8P4R	-DQS2
DM 2		3	4	DM2
MD 18		5	6	MD18
MD 22		7	8	MD22
MD 29	RN11	1	2 10/8P4R	MD29
MD 25		3	4	MD25
-DQS_3		5	6	-DQS3
DM 3		7	8	DM3
MD 26	RN12	1	2 10/8P4R	MD26
MD 30		3	4	MD30
MD 27		5	6	MD27
MD 31		7	8	MD31
MD 32	RN13	1	2 10/8P4R	MD32
MD 36		3	4	MD36
MD 33		5	6	MD33
MD 37		7	8	MD37
MD 39	RN14	1	2 10/8P4R	MD39
MD 35		3	4	MD35
MD 40		5	6	MD40
MD 44		7	8	MD44
-DQS_4	RN15	1	2 10/8P4R	-DQS4
DM 4		3	4	DM4
MD 34		5	6	MD34
MD 38		7	8	MD38
MD 45	RN16	1	2 10/8P4R	MD45
MD 41		3	4	MD41
DM 5		5	6	DM5
-DQS_5		7	8	-DQS5
MD 48	RN17	1	2 10/8P4R	MD48
MD 49		3	4	MD49
MD 52		5	6	MD52
MD 53		7	8	MD53
MD 50	RN18	1	2 10/8P4R	MD50
MD 51		3	4	MD51
MD 60		5	6	MD60
MD 61		7	8	MD61
DM 6	RN19	1	2 10/8P4R	DM6
-DQS_6		3	4	-DQS6
MD 54		5	6	MD54
MD 55		7	8	MD55
MD 56	RN20	1	2 10/8P4R	MD56
MD 57		3	4	MD57
DM 7		5	6	DM7
-DQS_7		7	8	-DQS7
MD 59	RN21	1	2 10/8P4R	MD59
MD 63		3	4	MD63
MD 58		5	6	MD58
MD 62		7	8	MD62

MD 20	RN2	1	2 10/8P4R	MD20
MD 16		3	4	MD16
MD 17		5	6	MD17
MD 21		7	8	MD21
MD 42	RN4	1	2 10/8P4R	MD42
MD 46		3	4	MD46
MD 43		5	6	MD43
MD 47		7	8	MD47

MD 7	RN8	1	2 10/8P4R	MD7
MD 3		3	4	MD3
MD 8		5	6	MD8
MD 9		7	8	MD9
MD 19	RN10	1	2 10/8P4R	MD19
MD 23		3	4	MD23
MD 24		5	6	MD24
MD 28		7	8	MD28

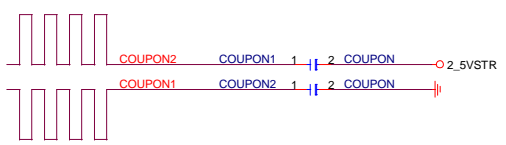
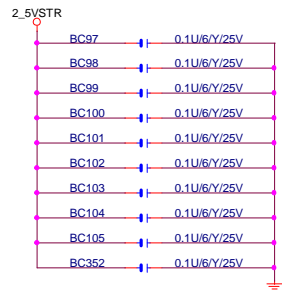

GIGABYTE		
Title		
DDR SERIAL TERM.		
Size B	Document Number	Rev
	GA-8PE800	1.1
Date:	Wednesday, March 05, 2003	Sheet 10 of 35

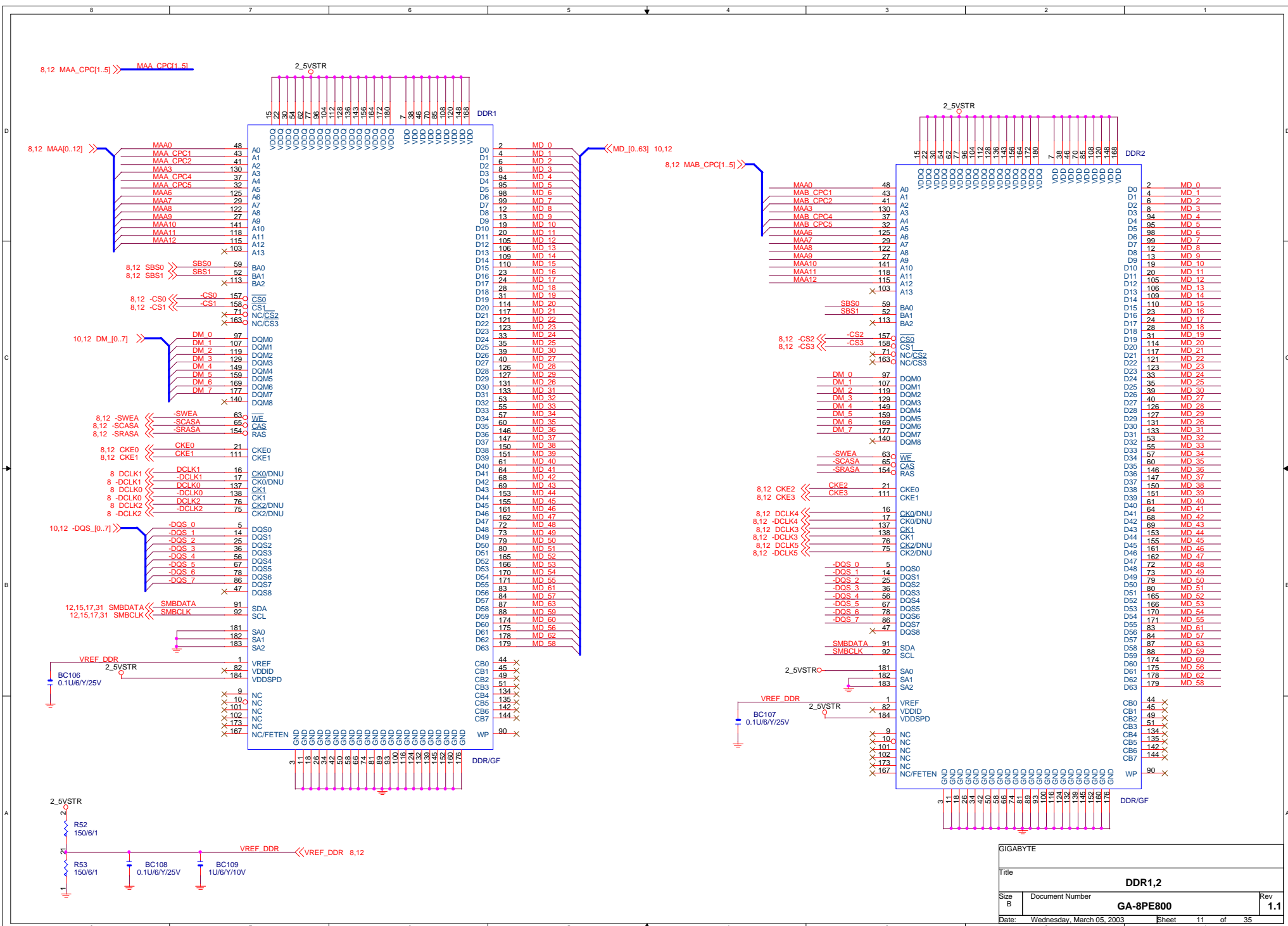

GIGABYTE		
Title		
DDR1,2		
Size B	Document Number	Rev
	GA-8PE800	1.1
Date:	Wednesday, March 05, 2003	Sheet 11 of 35

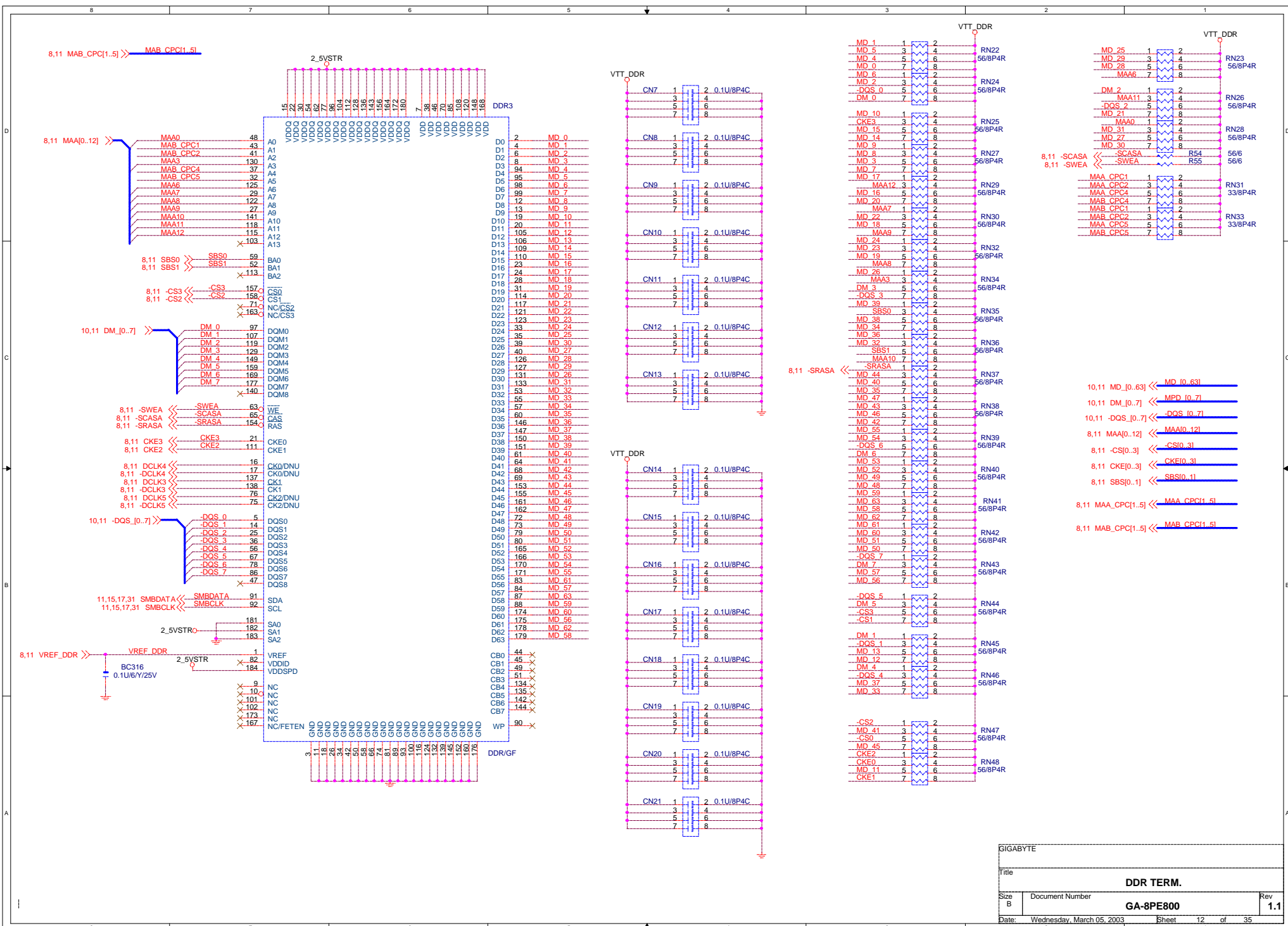

GIGABYTE		
Title		
DDR TERM.		
Size	Document Number	Rev
B	GA-8PE800	1.1
Date: Wednesday, March 05, 2003		
Sheet		12 of 35
2		1

7 SBA[0..7] << SBA[0..7]
 7 ST[0..2] << ST[0..2]
 7 GAD[0..31] << GAD[0..31]

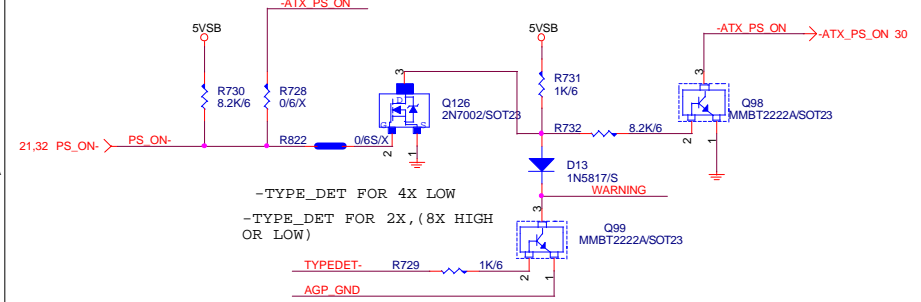
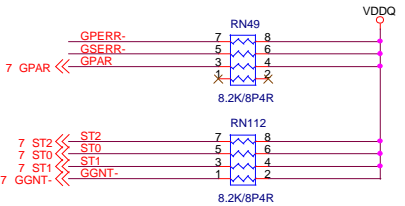
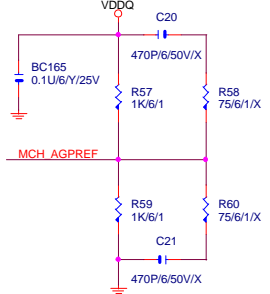
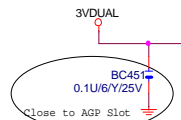
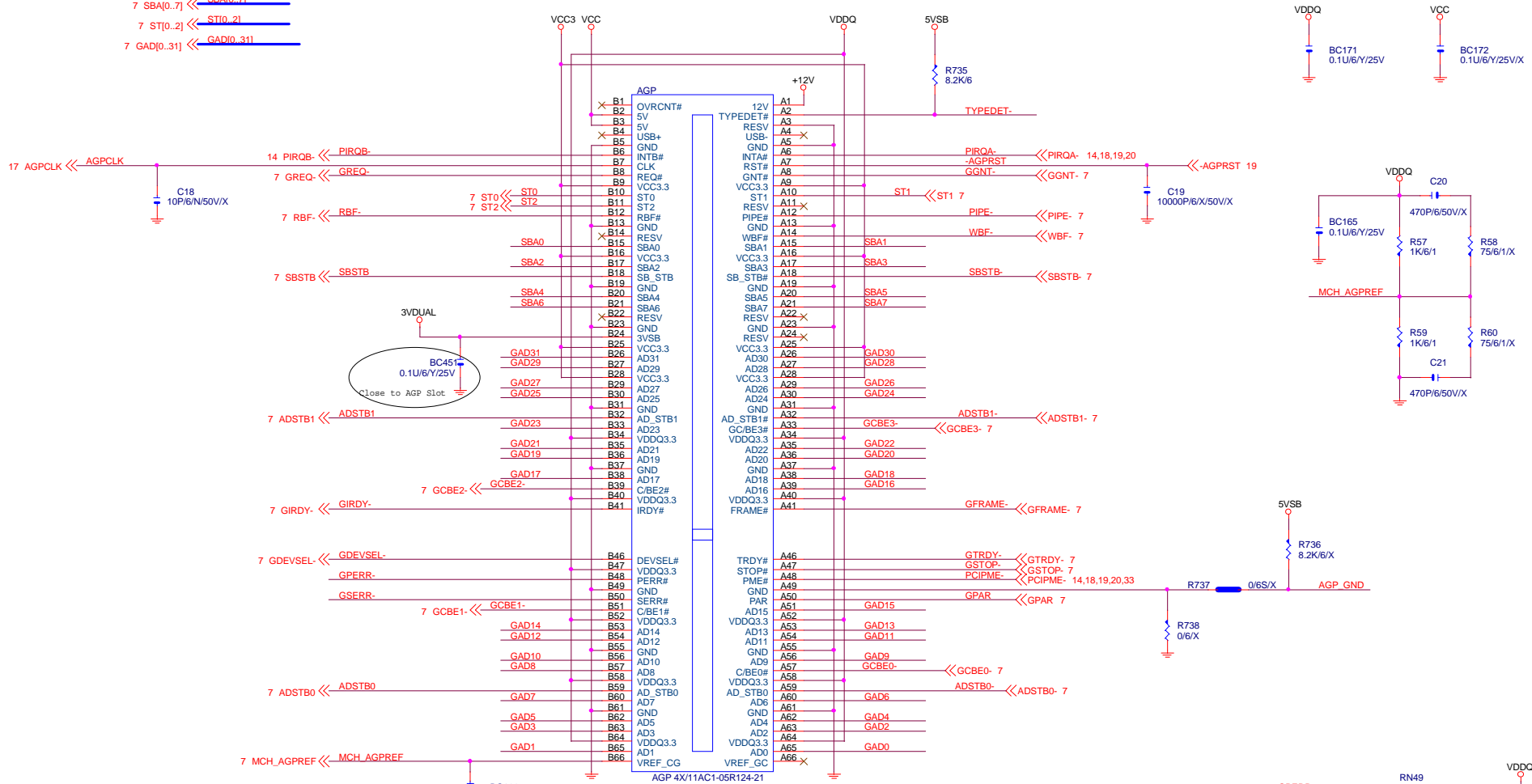

-TYPE_DET FOR 4X LOW
 -TYPE_DET FOR 2X, (8X HIGH OR LOW)
 TYPEDET- R729 1K/6
 AGP_GND

Layout 時整組線路均需靠近 AGP SLOT

GIGABYTE			
Title			
AGP SLOT			
Size	Document Number	Rev	
Custom	GA-8PE800	1.1	
Date:	Wednesday, March 05, 2003	Sheet 13 of 35	

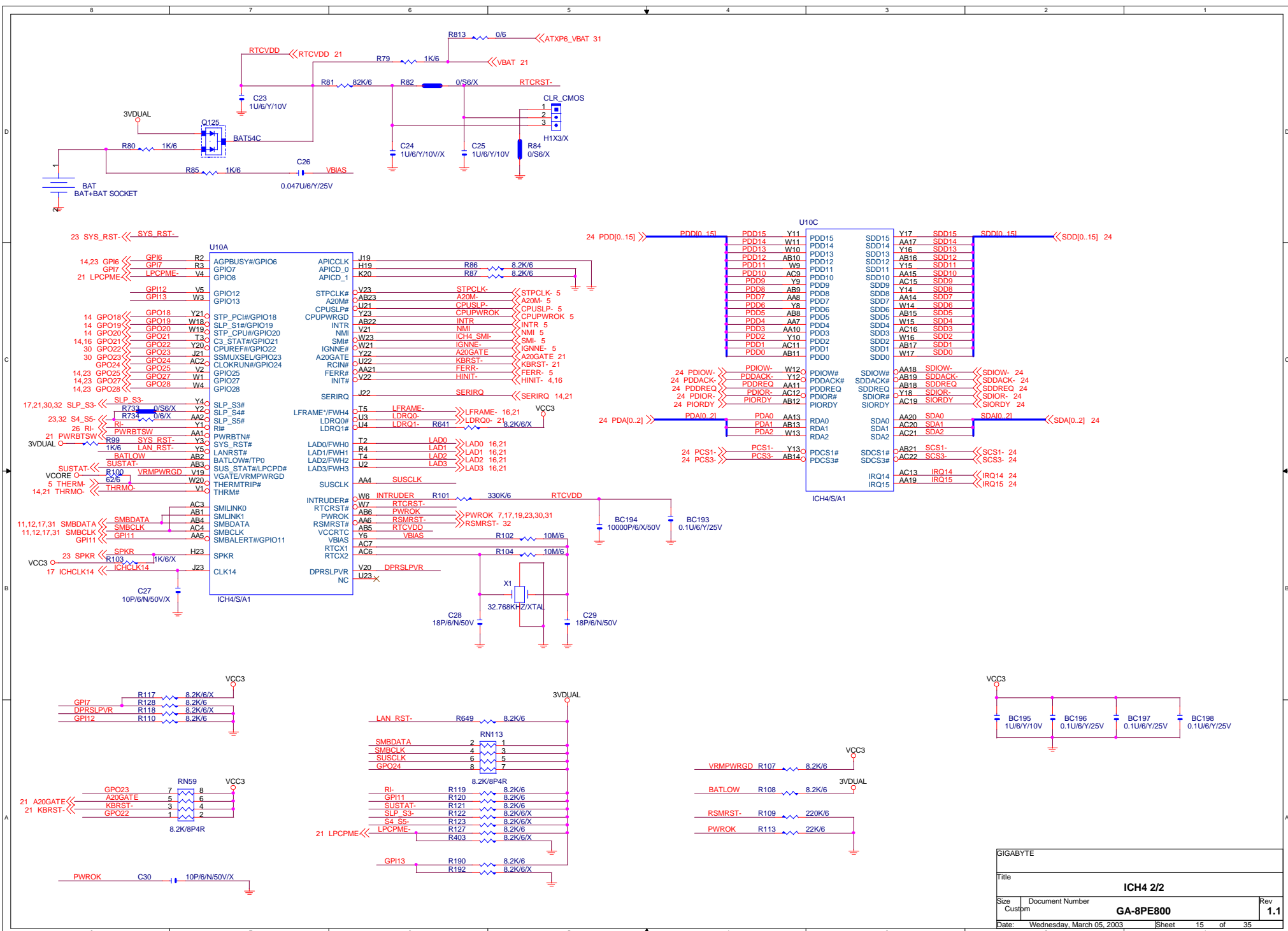

GIGABYTE		
Title		
ICH4 2/2		
Size	Document Number	Rev
Custom	GA-8PE800	1.1
Date:	Wednesday, March 05, 2003	Sheet 15 of 35

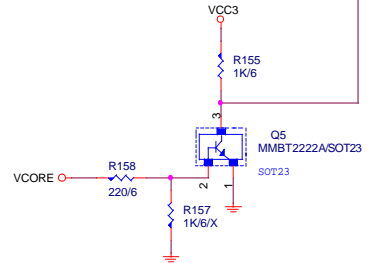
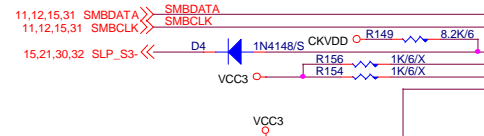
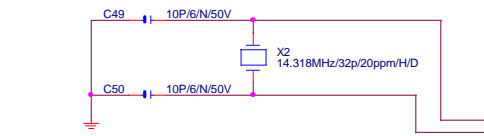
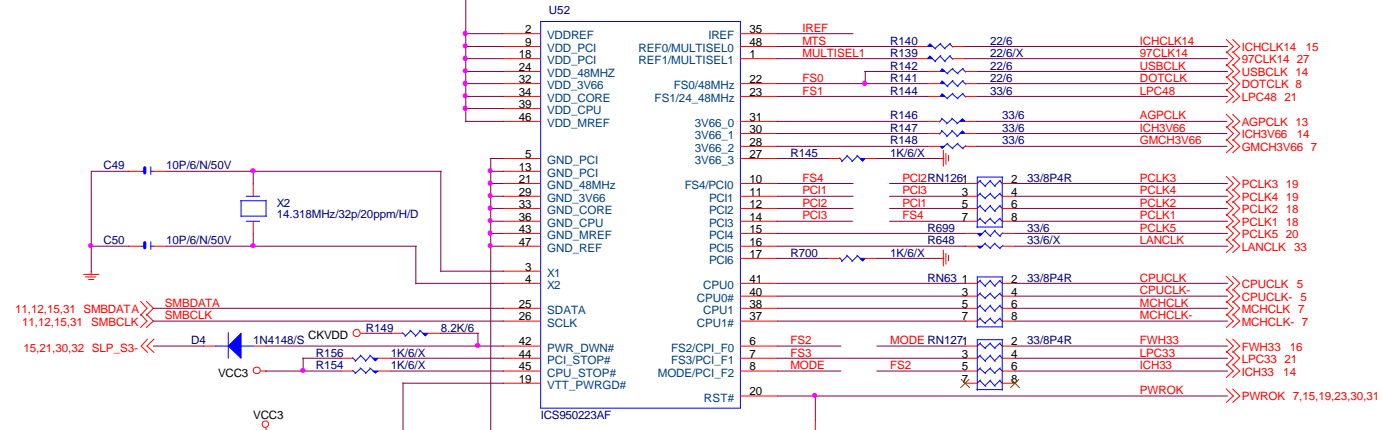
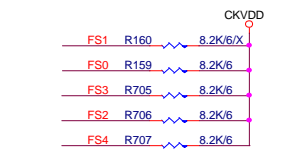
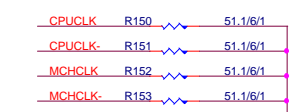
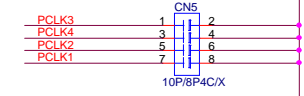
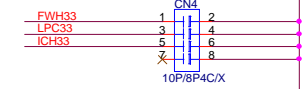
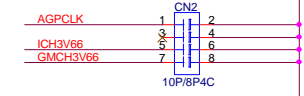
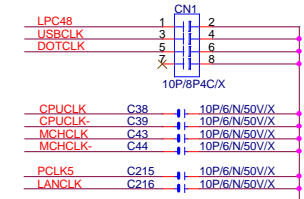
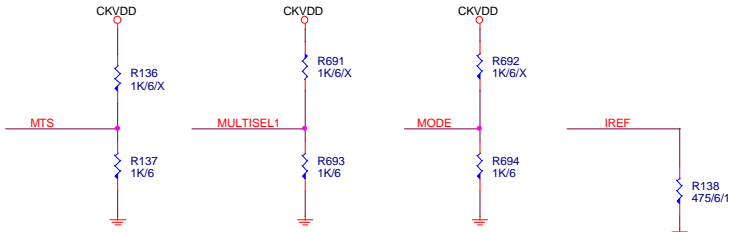
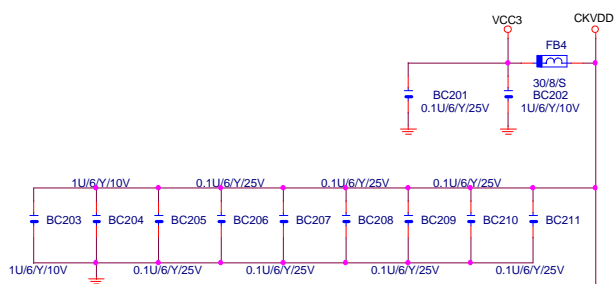

BSEL0 Pull-up at another page.

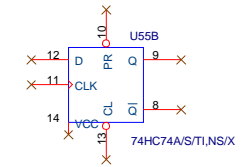
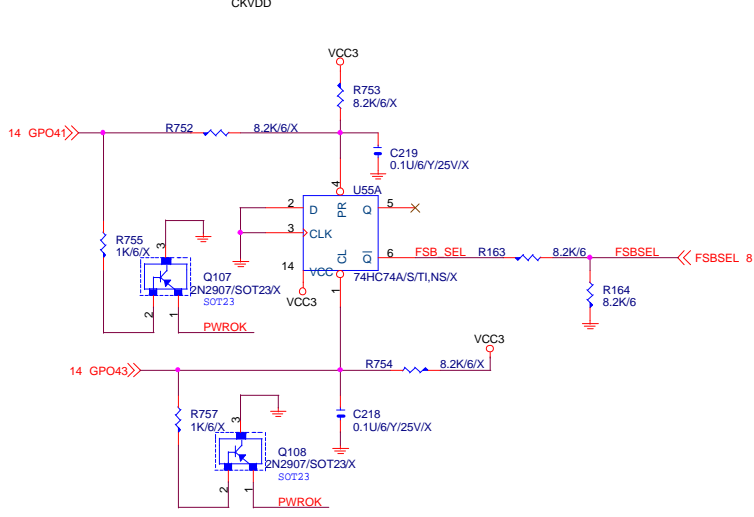
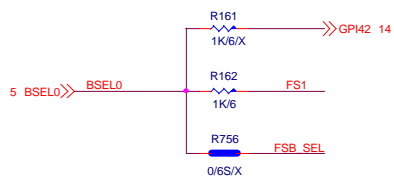

GIGABYTE			
Title			
CLOCK GENERATOR			
Size	Document Number	Rev	
Custom	GA-8PE800	1.1	
Date:	Wednesday, March 05, 2003	Sheet	17 of 35

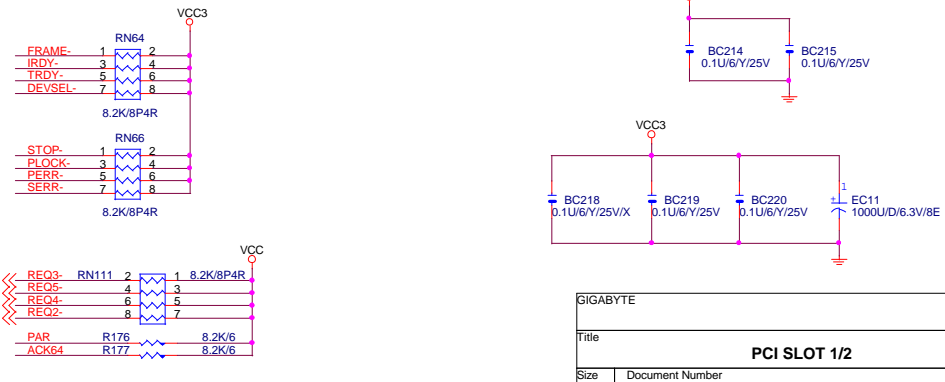
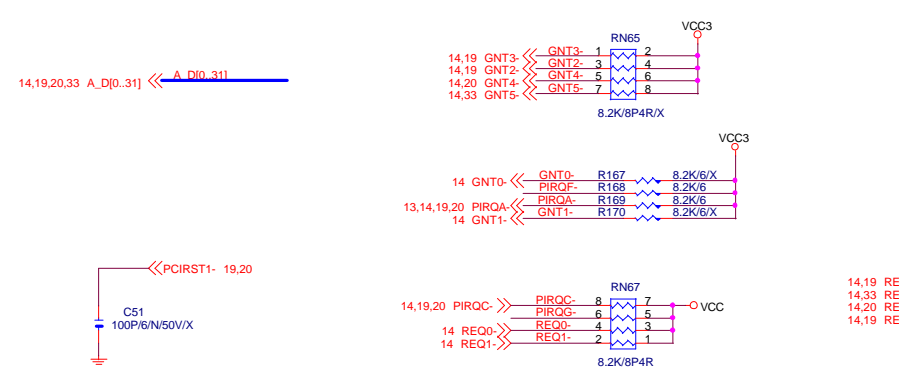
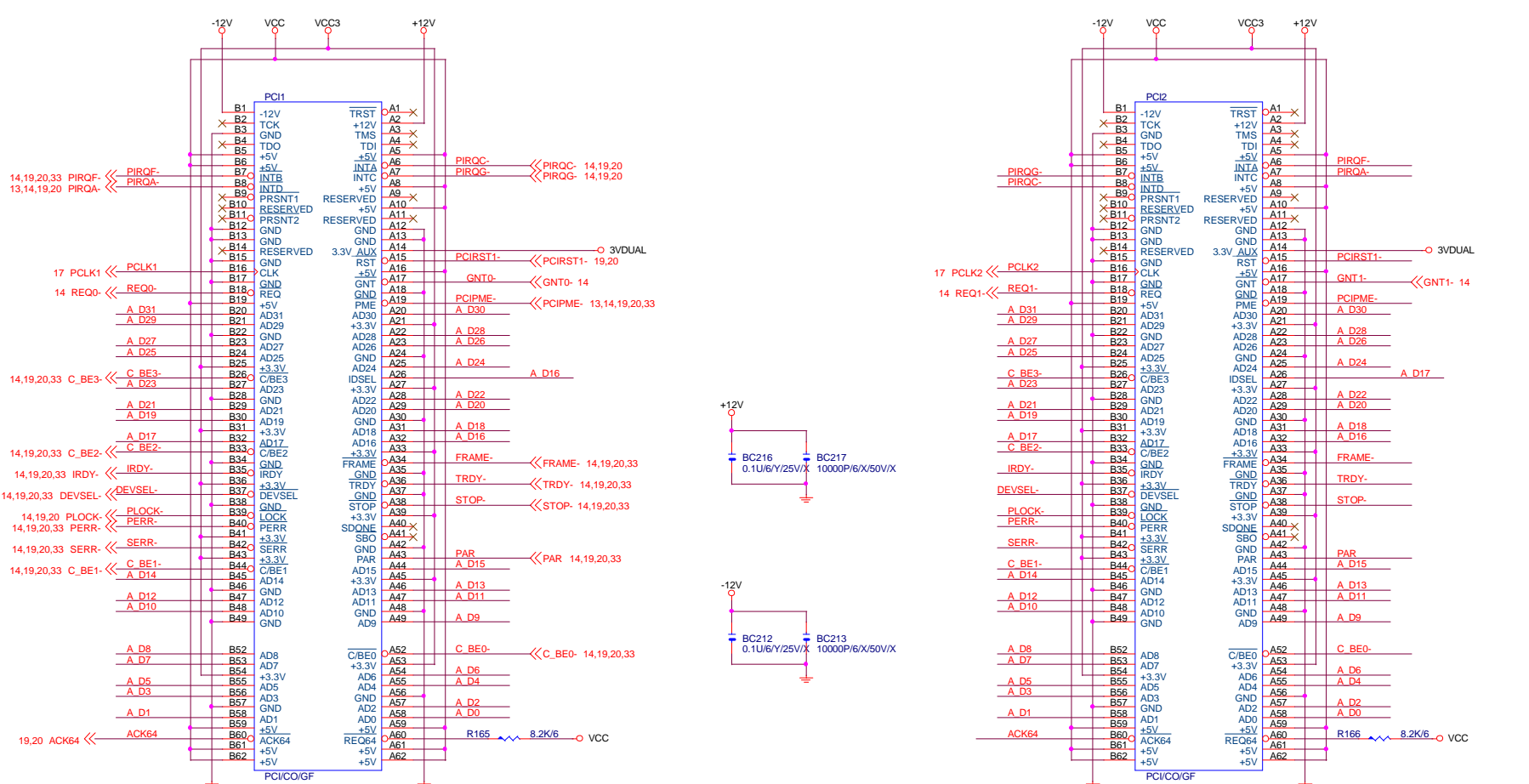

GIGABYTE		
Title		
PCI SLOT 1/2		
Size	Document Number	Rev
B	GA-8PE800	1.1
Date:	Wednesday, March 05, 2003	Sheet 18 of 35

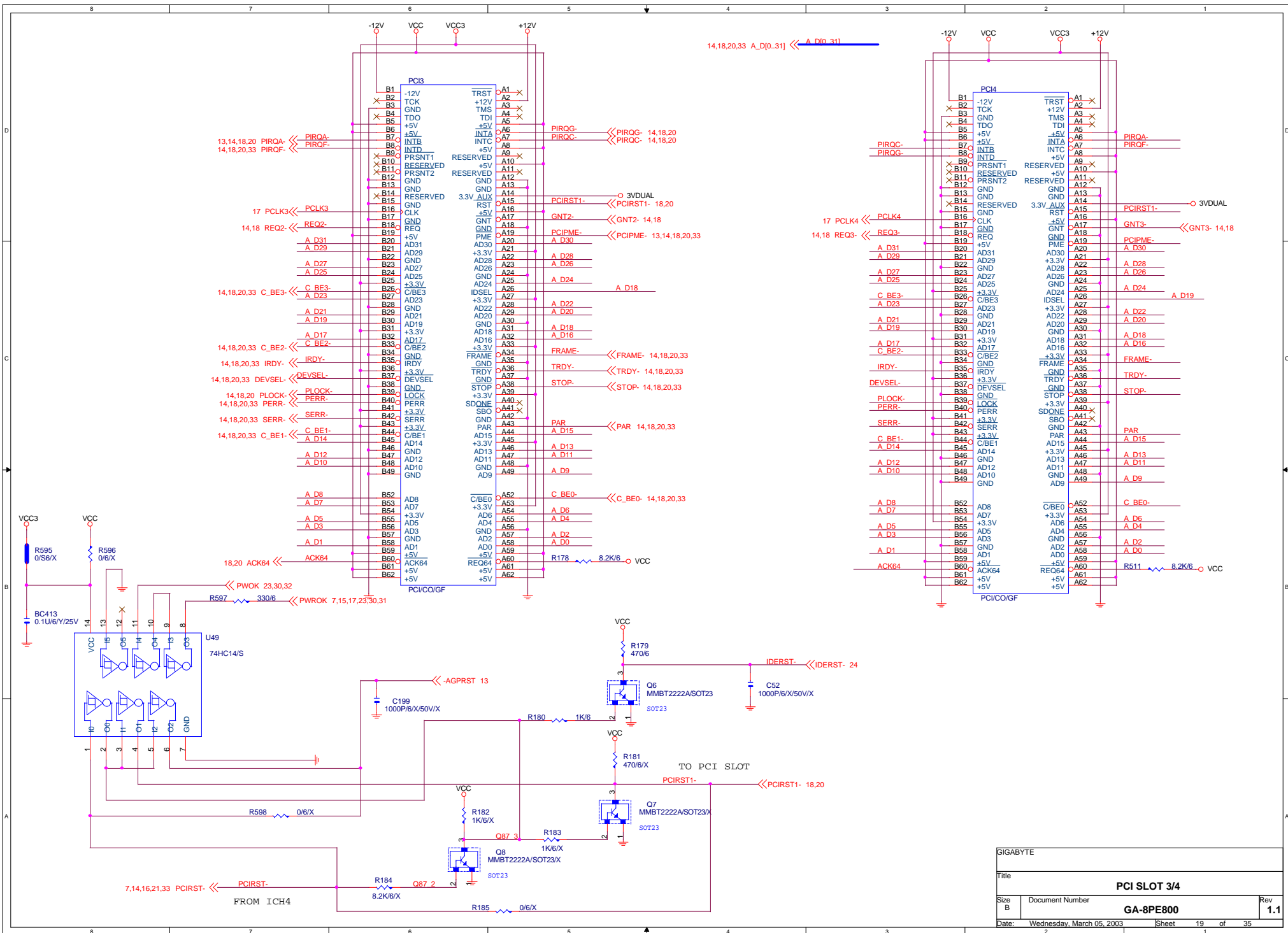

GIGABYTE		
Title		
PCI SLOT 3/4		
Size	Document Number	Rev
B	GA-8PE800	1.1
Date:	Wednesday, March 05, 2003	Sheet 19 of 35

14,18,19,33 A_D[0..31] << A_D[0..31]

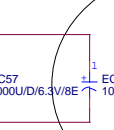
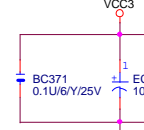
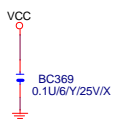
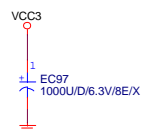
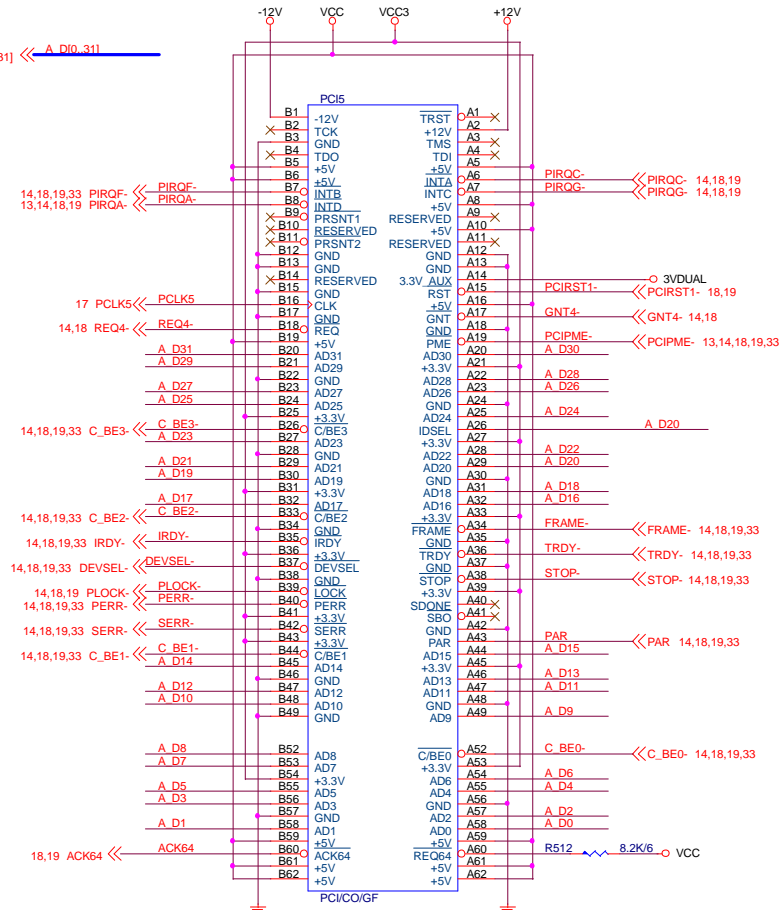

請靠近AC97使用端

GIGABYTE		
Title		
PCI SLOT 5		
Size	Document Number	Rev
B	GA-8PE800	1.1
Date:	Wednesday, March 05, 2003	Sheet 20 of 35

ICH4 USB2.0

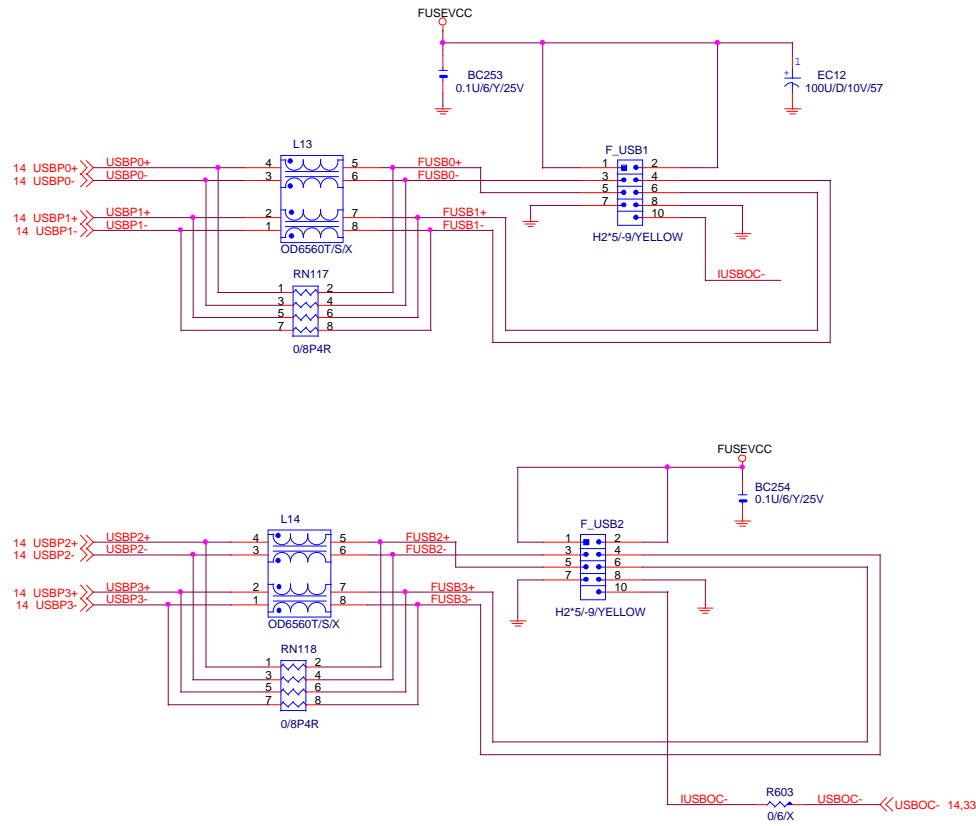

GIGABYTE		
Title		
ICH USB+LAN PORT		
Size B	Document Number	Rev
	GA-8PE800	1.1
Date:	Wednesday, March 05, 2003	Sheet 22 of 35

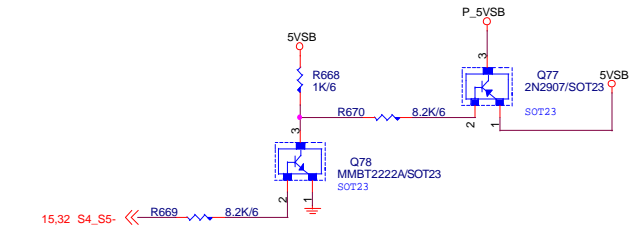
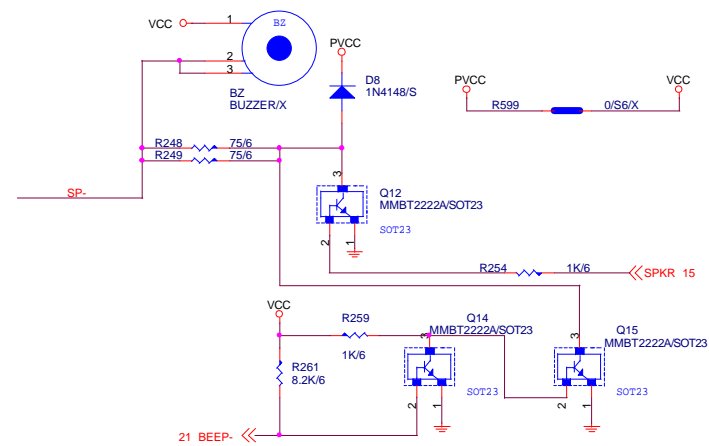
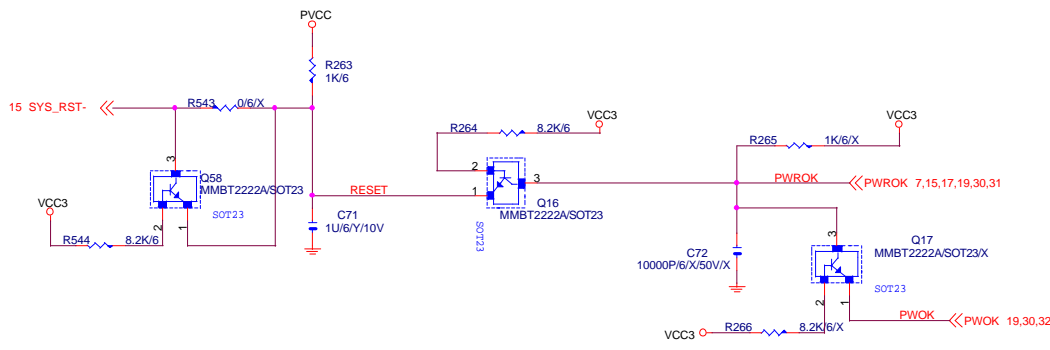

3 PIN POWER LED

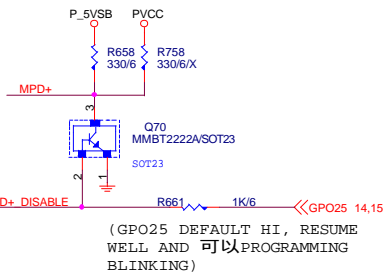
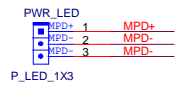

**(GPO28 DEFAULT HIGH, RESUME WELL)
States for green LED**

LED States	ACPI States	GPO28
ON	S1, S3	0
OFF	S0, S5	1

States for a single-color power LED

LED States	ACPI States	GPO25	GPO27	GPO35
OFF	S1, S3, S5	1	1	NO1
Steady Green	S0	0	1	0
Blinking Green	S0(message waiting)	0	B	0

NO1 GPO35 只需在 S1 PROGRAMMING LOW

States for a dual-color power LED

LED States	ACPI States	GPO25	GPO27	GPO35
OFF	S5	1	1	X
Steady Green	S0	0	1	0
Blinking Green	S0(message waiting)	0	B	0
Steady Yellow	S1, S3	1	0	NO1
Blinking Yellow	S1, S3(message waiting)	1	B	NO1

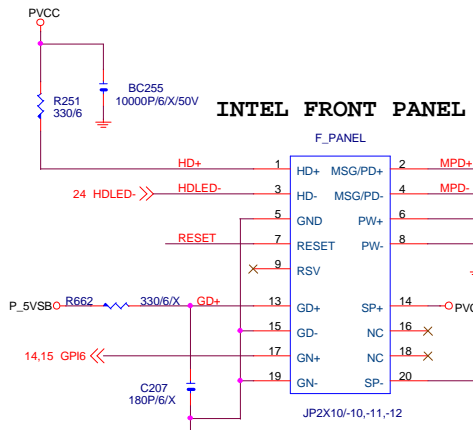

(DEFAULT HIGH, main power)

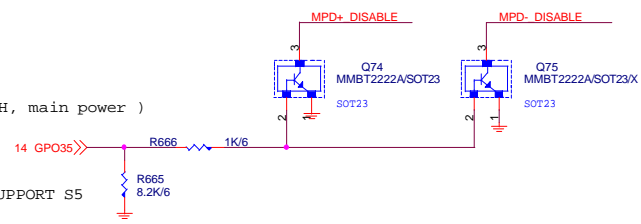

IF GPO35 有 SUPPORT S5
LOW, S0 HIGH
則不需使用此CIRCUIT

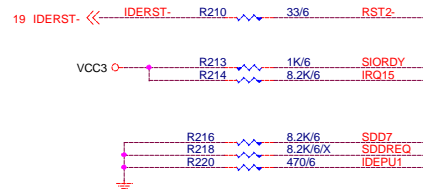
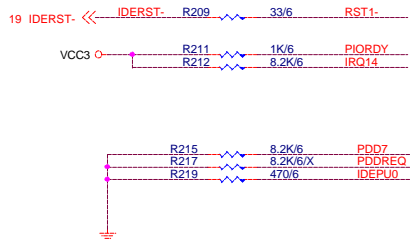
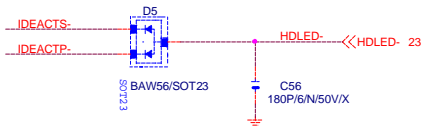

PRIMARY IDE CONNECTOR

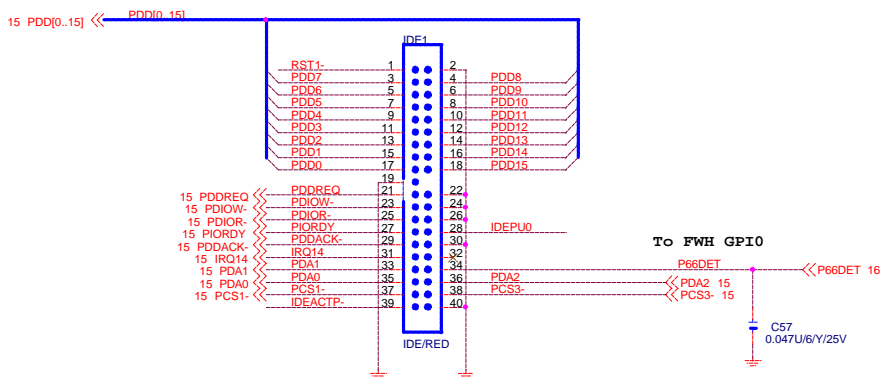

SECONDARY IDE CONNECTOR

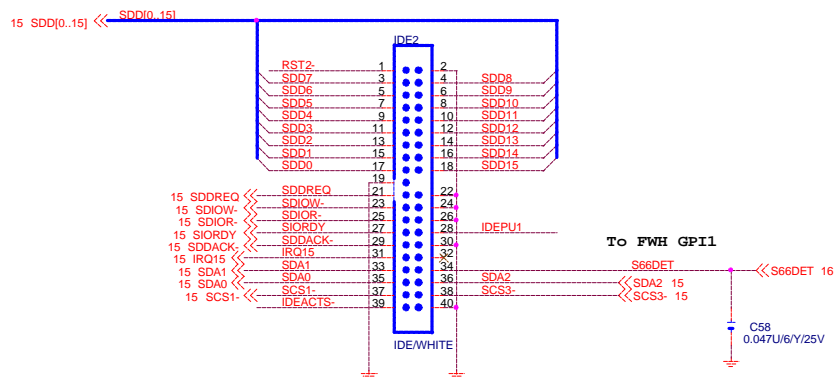

GIGABYTE		
Title		
IDE CONNECTOR		
Size B	Document Number	Rev
	GA-8PE800	1.1
Date:	Wednesday, March 05, 2003	Sheet 24 of 35

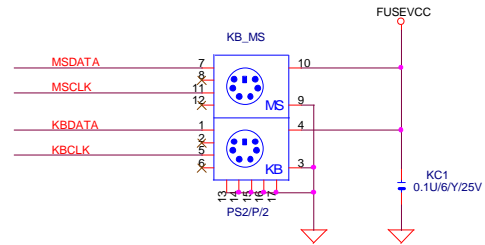
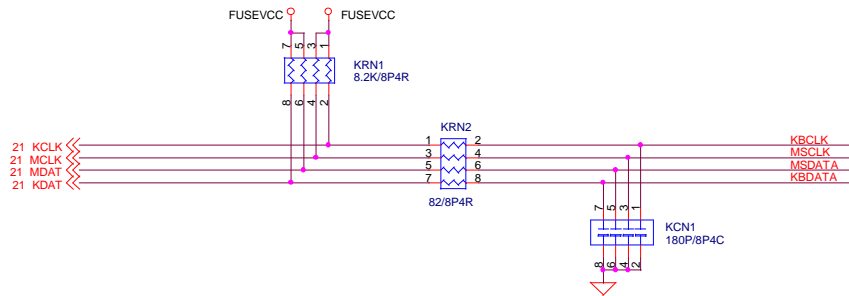
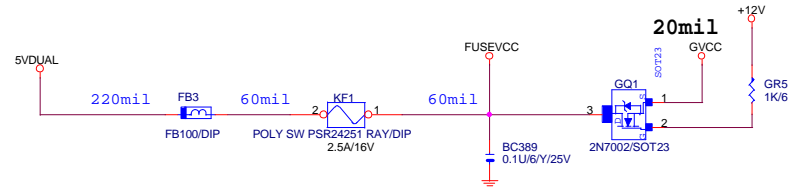

模組化線路

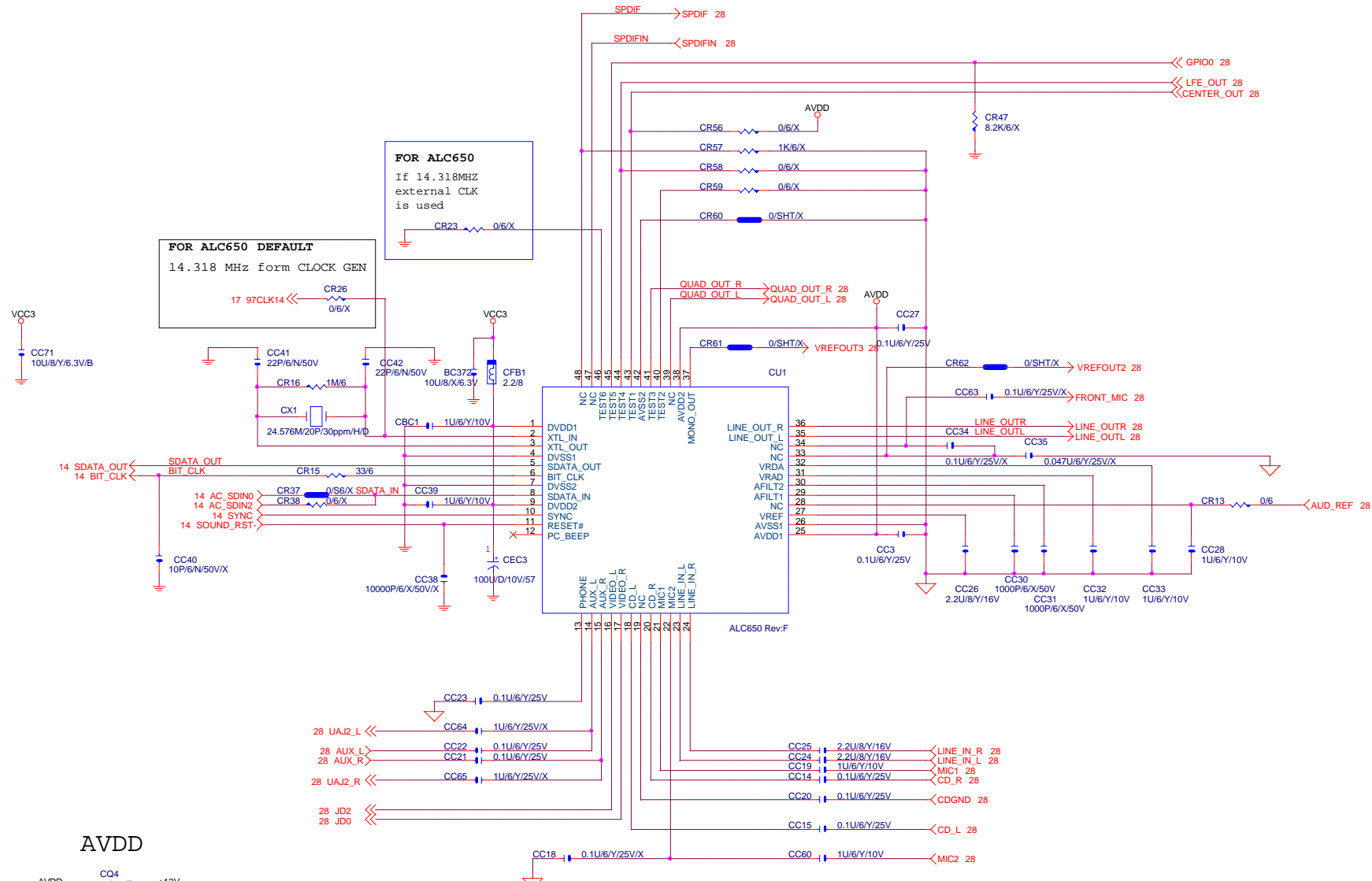

FOR ALC650 DEFAULT
 14.318 MHz form CLOCK GEN
 17 97CLK14

FOR ALC650
 If 14.318MHZ external CLK is used
 CR23 0/6/X

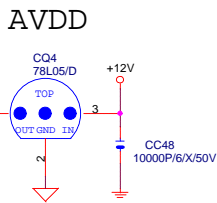

模組化線路

GIGABYTE CORP.		
Title AC97		
Size B	Document Number GA-8PE800	Rev 1.1
Date: Wednesday, March 05, 2003	Sheet 27	of 35

LINE-IN

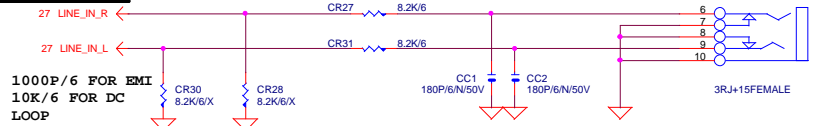

MIC

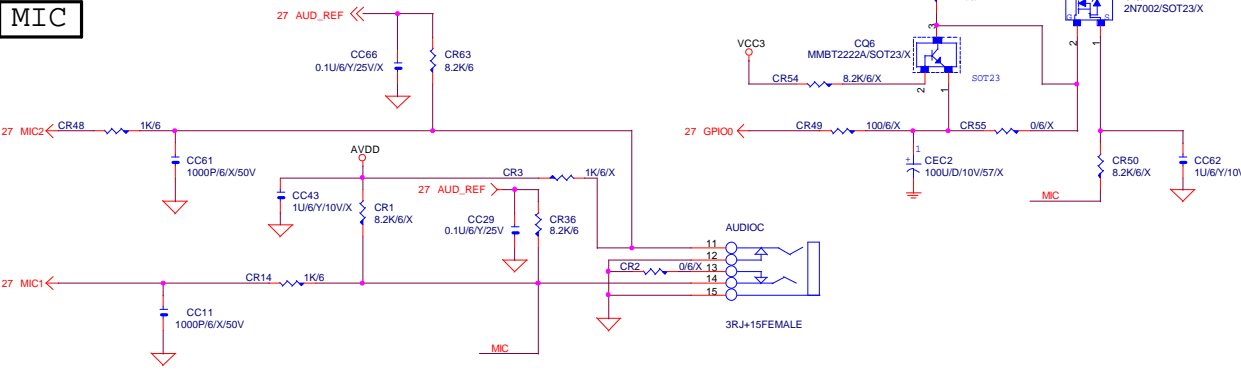

CDIN

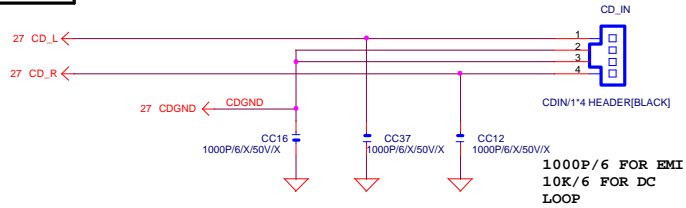

AUX_IN

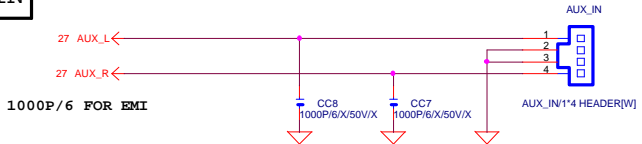

LINE OUT

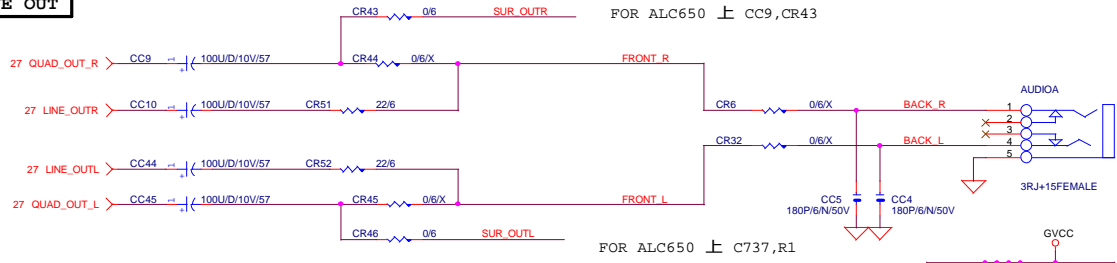

INTEL FRONT AUDIO

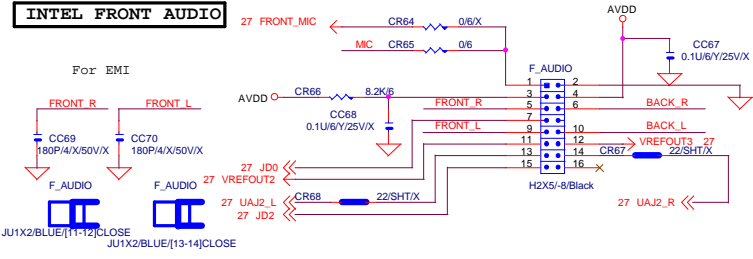

GAME_PORT

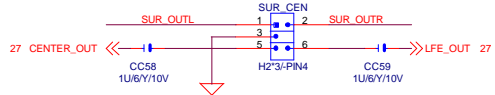
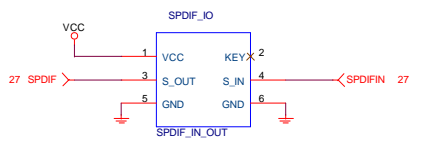
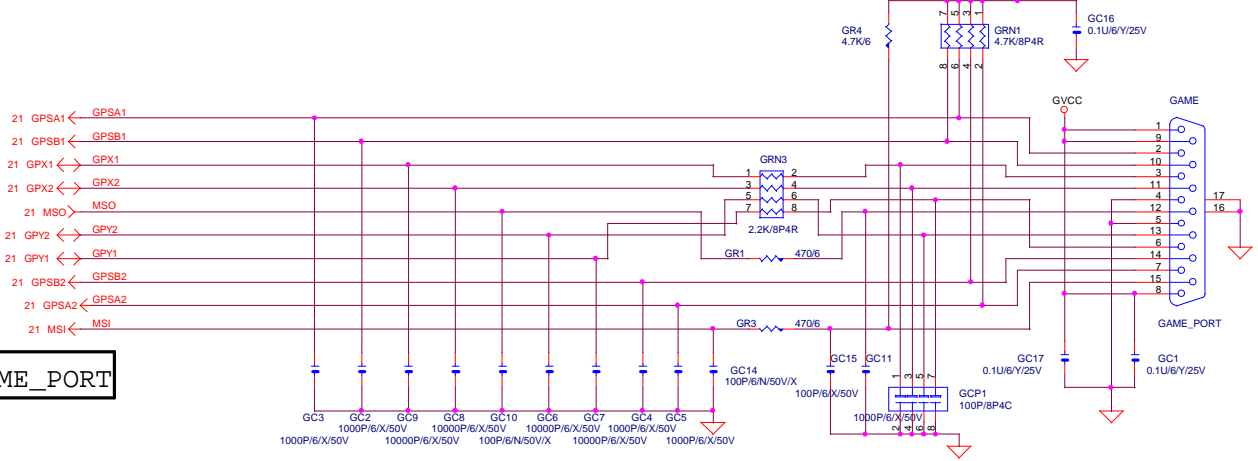

FOR SUPPORT 6 CHANNEL, SURROUND OUT CENTER OUT, LOW FREQUENCY EFFECT OUT

模組化線路

SIBYBYTE CORP.			
Title: PHONE JACK, GAME PORT			
Size: Custom	Document Number: GA-8PE800	Rev: 1.1	
Date: Wednesday, March 05, 2003	Sheet: 28	of 35	

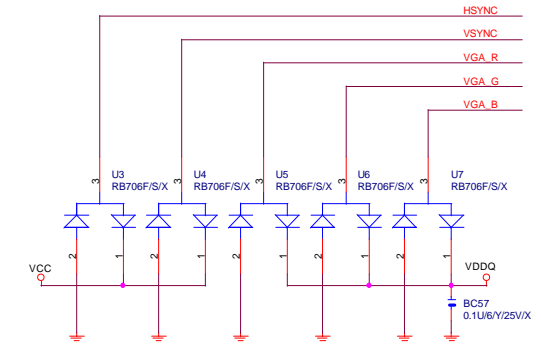
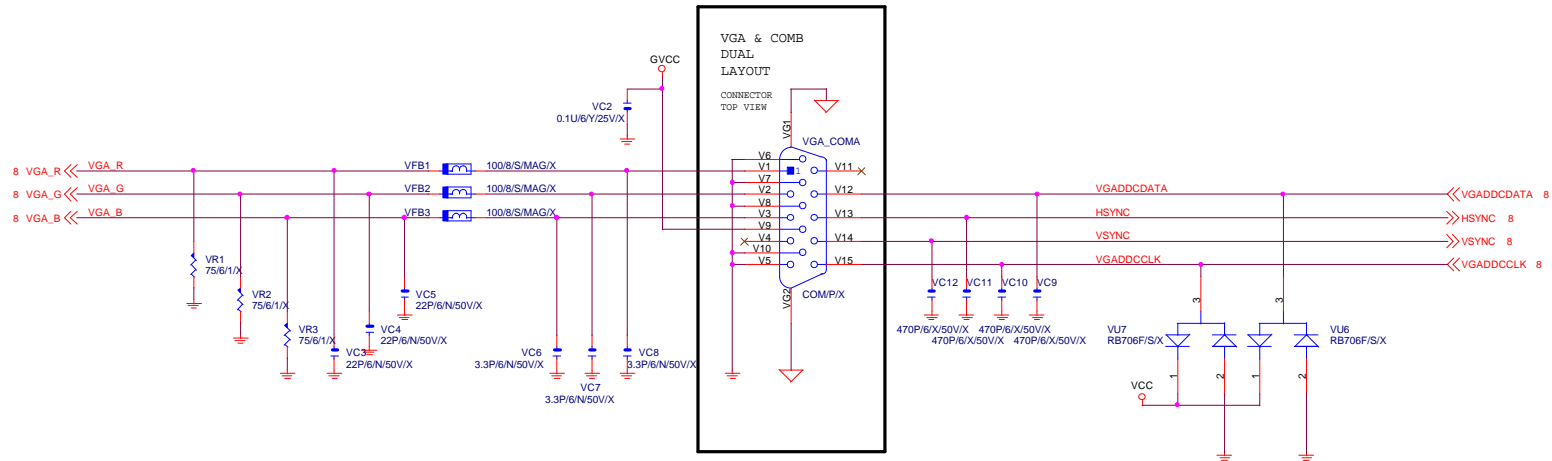

模組化線路

Title			VGA CONNECTOR		
Size	Document Number				Rev
Custom	GA-8PE800				1.1
Date:	Wednesday, March 05, 2003	Sheet	29	of	35

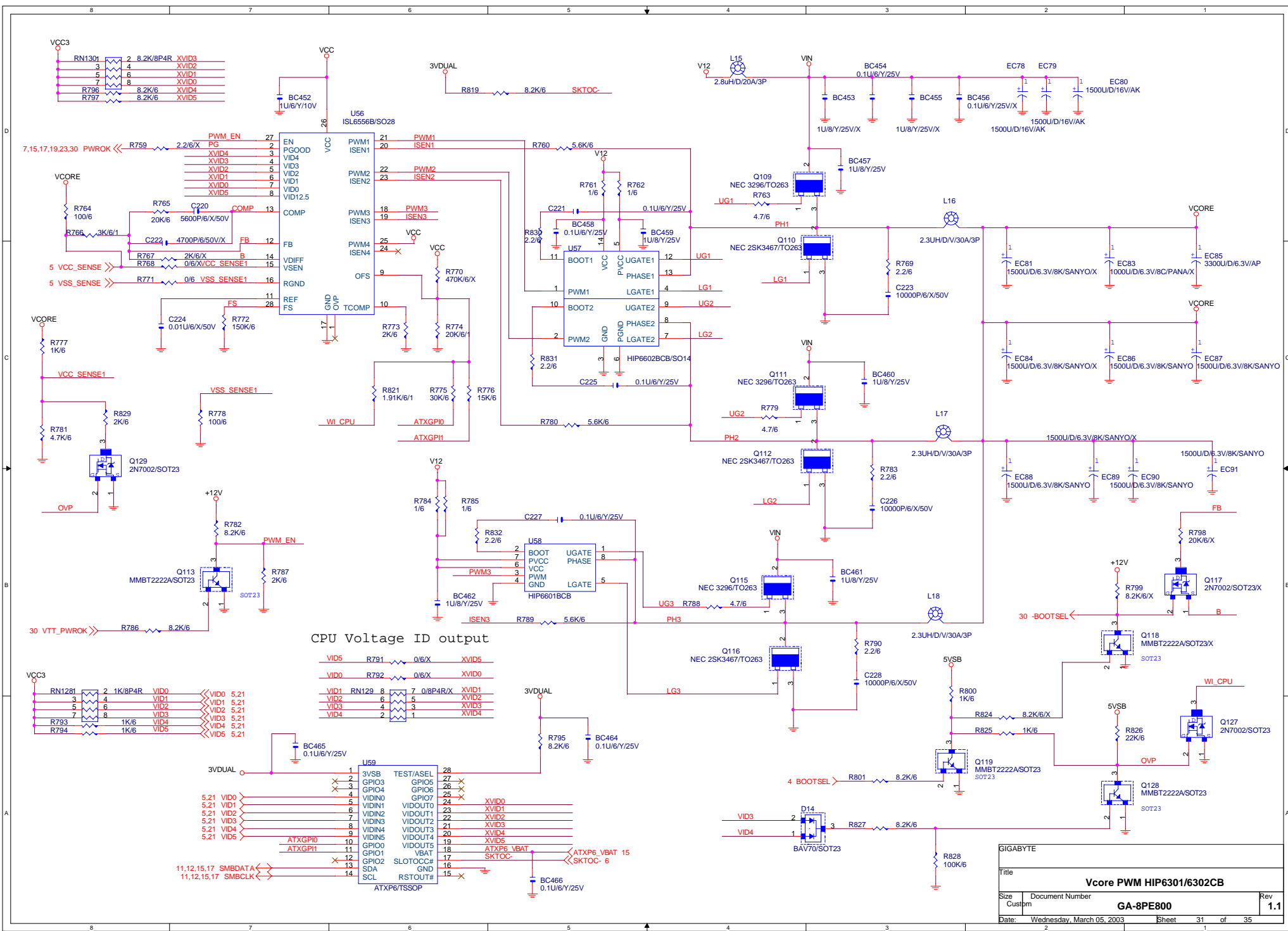

CPU Voltage ID output

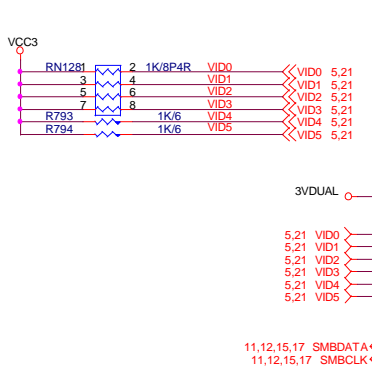

GIGABYTE			
Title			
Vcore PWM HIP6301/6302CB			
Size	Document Number	Rev	
Custom	GA-8PE800	1.1	
Date:	Wednesday, March 05, 2003	Sheet	31 of 35

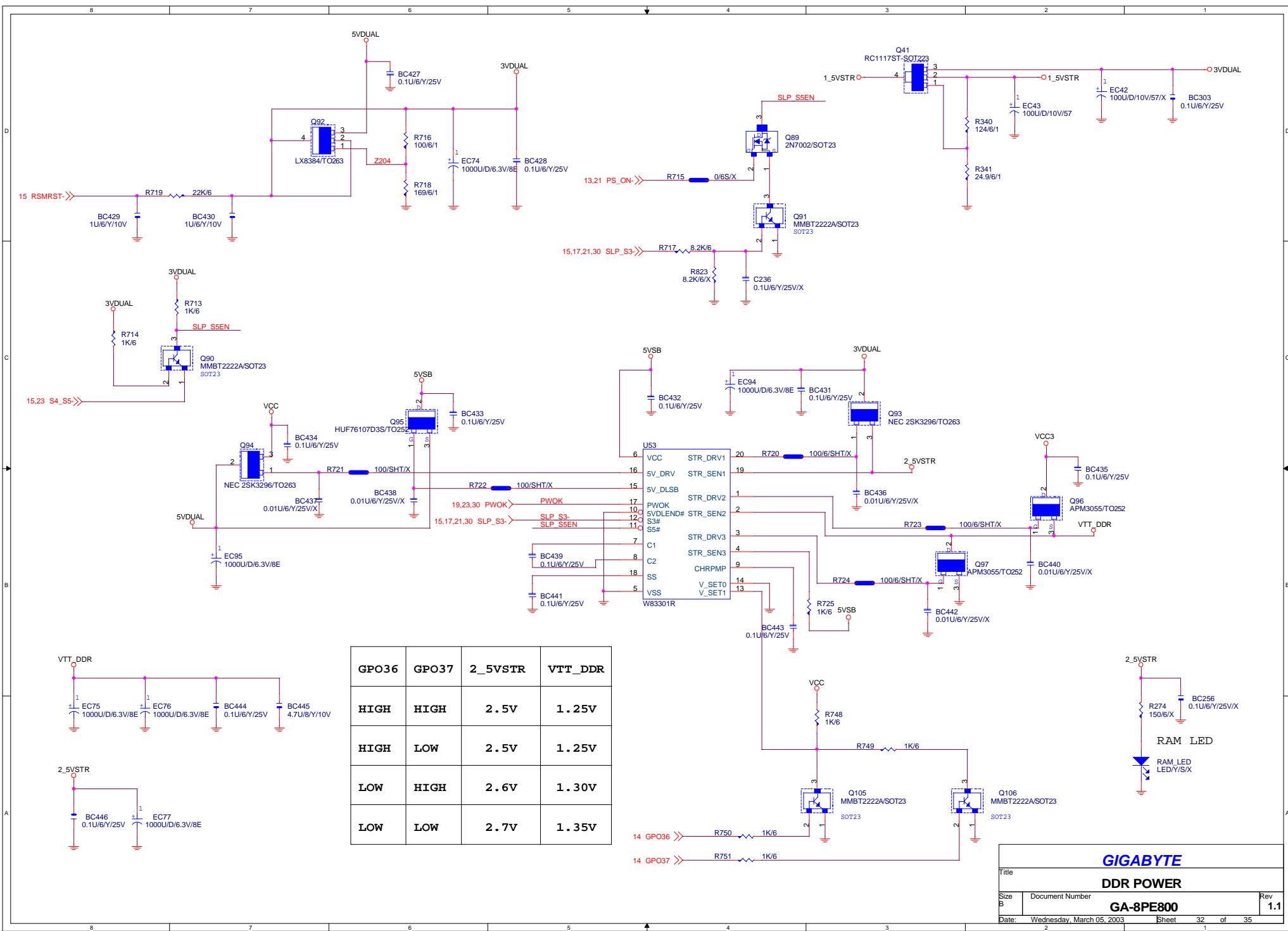

GPO36	GPO37	2_5VSTR	VTT_DDR
HIGH	HIGH	2.5V	1.25V
HIGH	LOW	2.5V	1.25V
LOW	HIGH	2.6V	1.30V
LOW	LOW	2.7V	1.35V

GIGABYTE

DDR POWER

Title		
Size B	Document Number	Rev
GA-8PE800		1.1
Date: Wednesday, March 05, 2003		
Sheet		32 of 35

LAN RTL8100 (REALTEK)

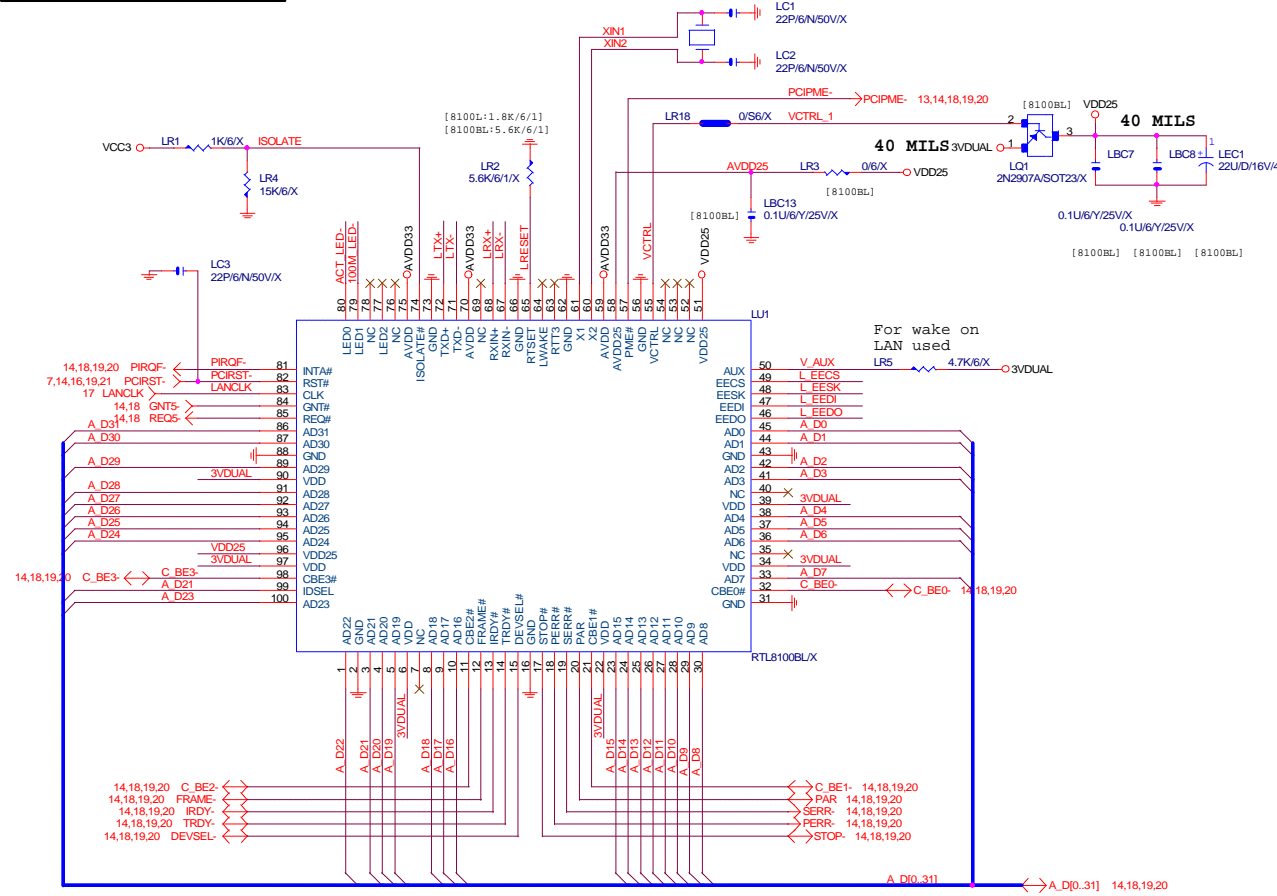

POWER DECOUPLING CAP.

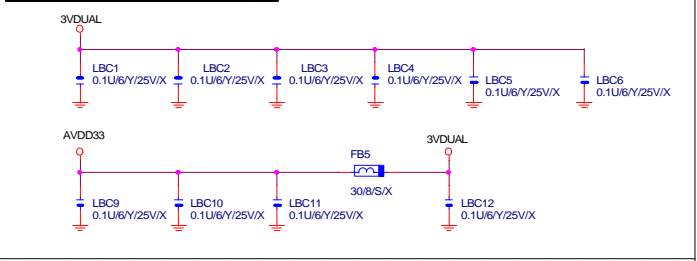

LAN EEPROM

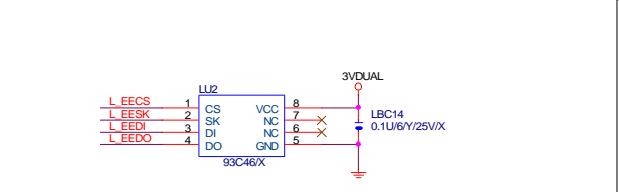

8100/8100B NOTE:
 Pin 65 pull-down (5.6K for 8100B)
 Pin 65 pull-down (1.8K for 8100)
 R502 remove pull-down (1.8K for 8100B)
 R502:0/6 pull-down (1.8K for 8100)

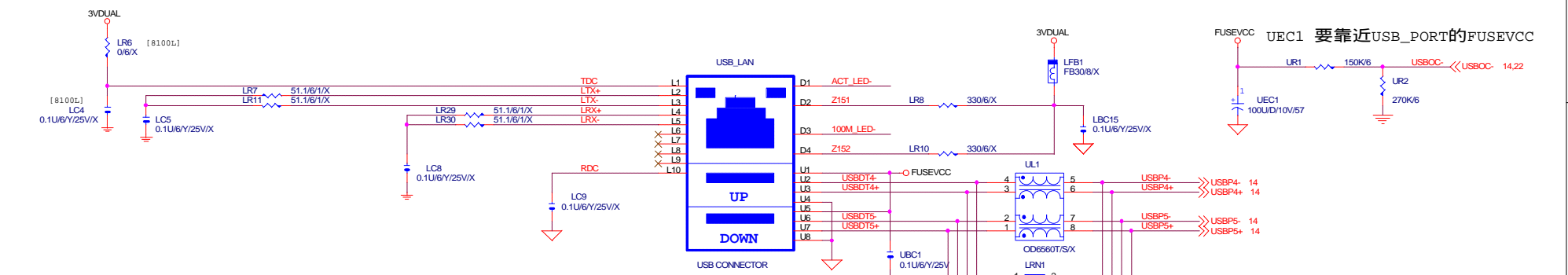

GIGABYTE		
LAN RTL8100B		
Title	Document Number	Rev
	GA-8PE800	1.1
Size Custom	Wednesday, March 05, 2003	Sheet 33 of 35

GIGABYTE GA-8PE667 PCI ROUNTING LIST *Revision : 0.1*

PCI DEVICE	IDSEL	INT	CLOCK	REQ	GNT	
PCI SLOT1	16	C,F,G,A	PCLK1	REQ0-	GNT0-	
PCI SLOT2	17	F,G,A,C	PCLK2	REQ1-	GNT1-	
PCI SLOT3	18	G,A,C,F	PCLK3	REQ2-	GNT2-	
PCI SLOT4	19	A,C,F,G	PCLK4	REQ3-	GNT3-	
PCI SLOT5	20	C,F,G,A	PCLK5	REQ4-	GNT4-	
LAN	21	F	LANCLK	REQ5-	GNT5-	

GIGABYTE GA-8PE667 GPIO LIST

Revision 0.1

SHEET

TITLE

GPI		
GPI0/REQA-		PULL DOWN 15K, detect IDE1 connector type.
GPI1/REQ5-		PULL DOWN 15K, detect IDE2 connector type.
GPI2/PIRQE-		PULL 8.2K TO VCC3
GPI3/PIRQF-		PULL 8.2K TO VCC3
GPI4/PIRQG-		PULL 8.2K TO VCC3
GPI5/PIRQH-		PULL 8.2K TO VCC3
GPI6		PULL 8.2K TO VCC3 (GREEN_BUTTON)
GPI7		NOT IMPLEMENTED
GPI8		PULL 8.2K TO 3VDUAL, LPC PME.
GPI9	NA	NOT IMPLEMENTED
GPI10	NA	NOT IMPLEMENTED
GPI11		PULL 4.7K TO 3VDUAL (SMBALERT)
GPI12		PULL DOWN 10K.
GPI13		PULL DOWN 10K, CNR_PRIMARY
GPI14	NA	NOT IMPLEMENTED
GPI15	NA	NOT IMPLEMENTED

SHEET

TITLE

GPO		
GPO16		PULL 8.2K TO VCC3
GPO17		PULL 8.2K TO VCC3 (GNT5-)
GPO18		PULL 8.2K TO VCC3
GPO19		PULL 8.2K TO VCC3
GPO20		PULL 8.2K TO VCC3
GPO21		PULL 8.2K TO VCC3
GPO22		PULL 8.2K TO VCC3
GPO23		PULL 8.2K TO VCC3
GPO24		PULL 1K TO 3VDUAL (TOP BLOCK)
GPO25		PULL 4.7K TO 3VDUAL, POWER LED CONTROL.
GPO26		NOT IMPLEMENTED
GPO27		PULL 8.2K TO 3VDUAL, POWER LED CONTROL.
GPO28		PULL 8.2K TO 3VDUAL, GREEN LED.
GPO32		PULL 8.2K TO 3VDUAL, BIOS WRITE PROTECT.
GPO35		PULL DOWN 10K, POWER LED CONTROL.