

GIGABYTE GA-8IE533 Schematics

Revision 2.0

SHEET

TITLE

| | |
|----|--------------------------|
| 01 | COVER SHEET |
| 02 | BOM & PCB MODIFY HISTORY |
| 03 | WILLIAMATE_478A |
| 04 | WILLIAMATE_478B |
| 05 | WILLIAMATE_478C |
| 06 | MCH-BROOKDALE-E_A |
| 07 | MCH-BROOKDALE-E_B |
| 08 | MCH-BROOKDALE-E_C |
| 09 | MD0~63 |
| 10 | DDR1~2 |
| 11 | DDR-TERM |
| 12 | AGP |
| 13 | ICH4_1 |
| 14 | ICH4_2 |
| 15 | FWH (SINGLE BIOS) |
| 16 | ICS950223 CLOCK GEN |
| 17 | PCI1_2 |
| 18 | PCI3_4 |
| 19 | PCI5 |
| 20 | ITE LPC I/O |
| 21 | IDE |
| 22 | KB_PS2 |

SHEET

TITLE

| | |
|-----|--------------------------------|
| 23 | COM_LPT_FDD |
| 24 | F-USB1 & F-USB2 |
| 25 | FPANEL |
| 26 | CODEC |
| 27 | AUDIO_GAMEPORT |
| 28 | AUDIO_SPDIF |
| 29 | DDR POWER |
| 30 | POWER1 |
| 31 | POWER2 |
| 32 | LAN RTL8100B & B-USB CONNECTOR |
| 33 | GPIO LIST |
| 34 | PCI ROUNT LIST |
| 35 | |
| 36 | |
| 37 | |
| 38 | |
| PCB | 十美,育富,群祥,智恩 4v藍C |

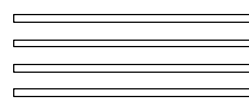
| | |
|---|-------------------------------------|
|  | |
| GIGABYTE | |
| Title COVER SHEET | |
| Size Custom | Document Number GA-8IE533 |
| Date: Wednesday, October 30, 2002 | Rev 2.0 |
| Sheet 1 of 34 | |

Model Name: 8IE533

Version: 2.0

91/04/30

BOM 修改 History

| BOM 版本 | 修改項目內容 | 修改原因 |
|----------------|-------------------------------------|--|
| 0.1A-0322 | 9M8IE-00-10A --> 9M8IE-00-01A | 參考右邊修改內容 |
| 0.1B-0401 | 9M8IE-00-01A --> 9M8IE-00-01B | COST DOWN |
| 1.0B-0409 | 9M8IE-00-01B --> 9M8IE-00-10B | 統一電解電容 |
| 1.1A-0413 | 9M8IE-00-10B --> 9M8IE-00-11A | INTEL FRONT PANEL&6 CHANNEL |
| 1.1AECN-0418 | 9M8IE-00-11A --> 9M8IE-00-11A | ADD Q162(2N2907/SOT23) BASE RESISTOR |
| 1.1B | 9M8IE-00-11A --> 9M8IE-00-11B | Change 1000uF 10V 8*14 to 1000uF 6.3V 8*14 |
| RD-1.1B | 9M8IE-00-11B --> 9M8IE-RD-11B | Change ITE8702 TO ITE8712 |
| RD-1.1C | 9M8IE-RD-11B --> 9M8IE-RD-11C | Fix PWM FAN5093 Current Limite issue |
| 2.0A | 9M8IE-00-11C --> 9M8IE-00-20A | 1.PCB CHANGE 2.包材修改 |
| 2.0B | 9M8IE-00-20A --> 9M8IE-00-20B | Clock 24MHz for LPC R755 from 33 ohm to 56 ohm |
| 8IE533-10A | 9M8IE-00-20B --> 9M8IE533-00-10A | 1.ADD AGP,VCORE,DDR OVER VOLTAGE 2.ADD AGP CARE 2X,4X DETECTT |
| 8IE533-10A-PVT | 9M8IE-00-10A --> 9M8IE533-00-10A | 1.ADD LPT CAP FOR EMI |
| 8IE533-10B | 9M8IE-00-10A --> 9M8IE533-00-10B | 1.ADD FLAT IDE2 CABLE |
| 10B-0828 | 9M8IE533-00-10B --> 9M8IE533-00-10B | 1. ADD MOSFET 15N03 2. REMOVE AGP WARING STICKER & NOTICE |
| 10C-0913 | 9M8IE533-00-10B --> 9M8IE533-00-10C | 1. FOR C-STEPING CPU HANG 2.PWM HIGT SIDE MOSFET R1597,R1606 2.2 --> 4.7ohm 3. AGP 2X DETECT PORTECT R1654 1K --> 8.2K , R1663 8.2K --> 1K |
| 10D-1001 | 9M8IE533-00-10C --> 9M8IE533-00-10D | 1.FOR ALTAS FP-350W ATX POWER FAIL DDR POWER Q166 MMBT2222 --> 2N7002 2. AUX_12V --> ATX_12V |
| 20A-1004 | 9M8IE533-00-10D --> 9M8IE533-00-20A | 1. HIGH SIDE MOS TO263 Q148,Q151 NEC3467,IPB07N03,FA6070 2. LO SIDE MOS TO263 Q150,Q152,Q1,Q2 NEC3296,IPB15N03,FA6035 3. LO SIDE MOS GATE R1599,R1607 2.2 ohm 4. D60,D61 1N5817 REMOVE 5. ADD Q67 PMBZ5237B,R1620=10,R1630=0 6. AGP_LED --> 2X_LED 7. IDE1,IDE2,FDD 改防斷裂 AGP 改紫色 |

SPDIF, ATX_12V, FAN改防呆

PCB version 變更(線路及Layout Change)Histoty

| PCB 版本 | 修改項目內容 | 修改原因 |
|--------------|-------------------------------------|---|
| 0.1 | 8IEXP REV1.0 --> 8IE REV0.1 | |
| 1.0 | 8IE REV0.1 --> 8IE REV1.0 | |
| 1.1 | 8IE REV1.0 --> 8IE REV1.1 | INTEL FRONT PANEL&6 CHANNEL |
| 1.1 1 | 8IE REV1.1 --> 8IE REV1.1 1 | ADD Q162(2N2907/SOT23) BASE RESISTOR |
| 2.0 | 8IE REV1.1 1 --> 8IE REV2.0 | 修改CPU RM 孔徑 |
| 8IE533 1.0 | 8IE REV2.0 --> 8IE533 REV1.0 | 1.ADD AGP,VCORE,DDR OVER VOLTAGE 2.ADD AGP CARE 2X,4X DETECTT 3.LPC IO CHANGE TO ITE8712 -GB 4.USB CHANGE : F_USB2 (USB0,1) , F_USB0 (US 4,5) 5. ADD DDR POWER OFF IN FIRST POWER ON |
| 8IE533 2.0 | 8IE533 REV1.0 --> 8IE533 REV2.0 | 1.PWM MOSFET TO-252 --> TO-263 2. ADD PWM BOOTB CONTROL CIRCUIT |
| BOM | | |
| 20A-1017-PVT | 9M8IE533-00-20A --> 9M8IE533-00-20A | 1. GPI34 CHANGE TO LOW FOR DDR DRIVING HIGHER,R1425 8.2K REMOVE , ADD R1424 8.2K 2. F_PANEL CHANGE TO COLOR 3.ADD 32.768K SHORT WIRE 4. F_AUDIO SHUNTER WHITE --> BLUE 5. Q67 ZENER ADD MMBZ5237B 6. SPDIF SPDIF IN ATX 12V FAN 改成主料(防呆),替料(未防呆) |

GIGABYTE

Title BOM & PCB MODIFY HISTORY

Size Custom Document Number

GA-8IE533

Rev 2.0

Date: Wednesday, October 30, 2002

Sheet 2 of 34

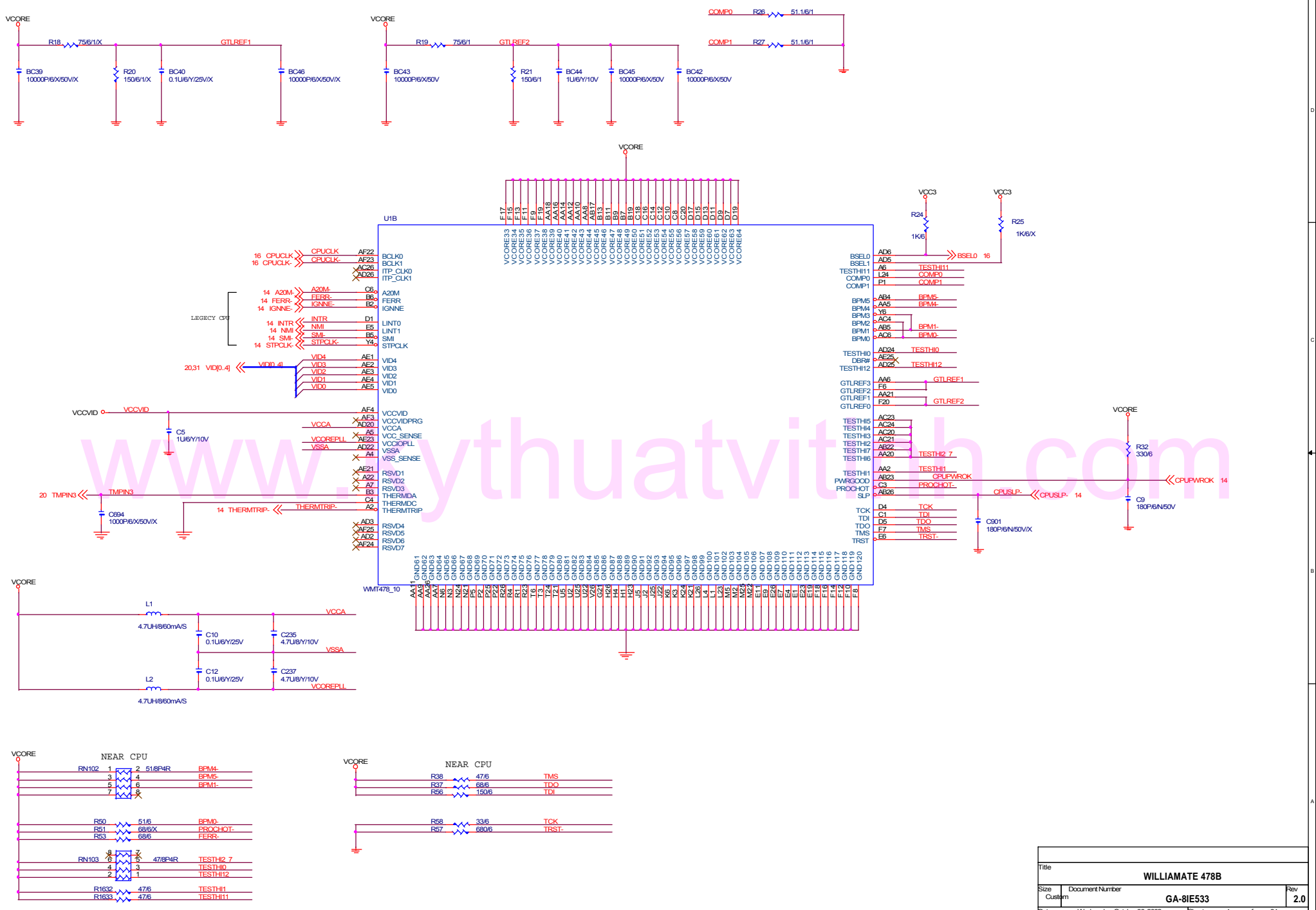

| | | | | | |
|--------|-----------------------------|-------|-----------------|----|-----|
| Title | | | WILLIAMATE 478B | | |
| Size | Document Number | | | | Rev |
| Custom | GA-8IE533 | | | | 2.0 |
| Date: | Wednesday, October 30, 2002 | Sheet | 4 | of | 34 |

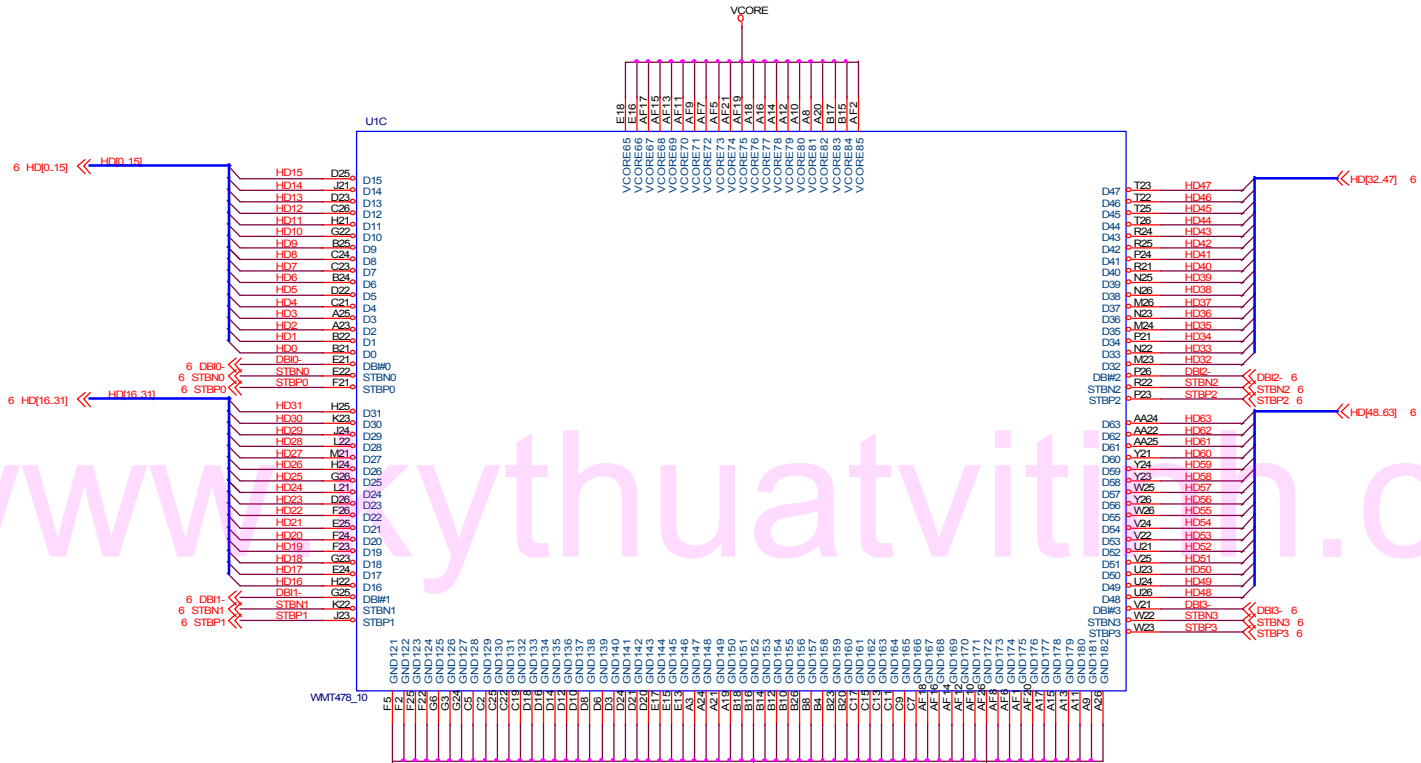

www.kythuavietnam.com

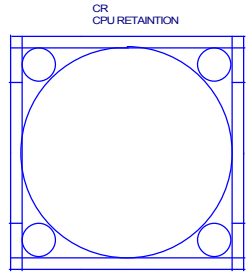

| | | | | |
|--------|-----------------------------|-------|-----------------|-------|
| Title | | | WILLIAMATE 478C | |
| Size | Document Number | Rev | | 2.0 |
| Custom | GA-8IE533 | | | |
| Date: | Wednesday, October 30, 2002 | Sheet | 5 | of 34 |

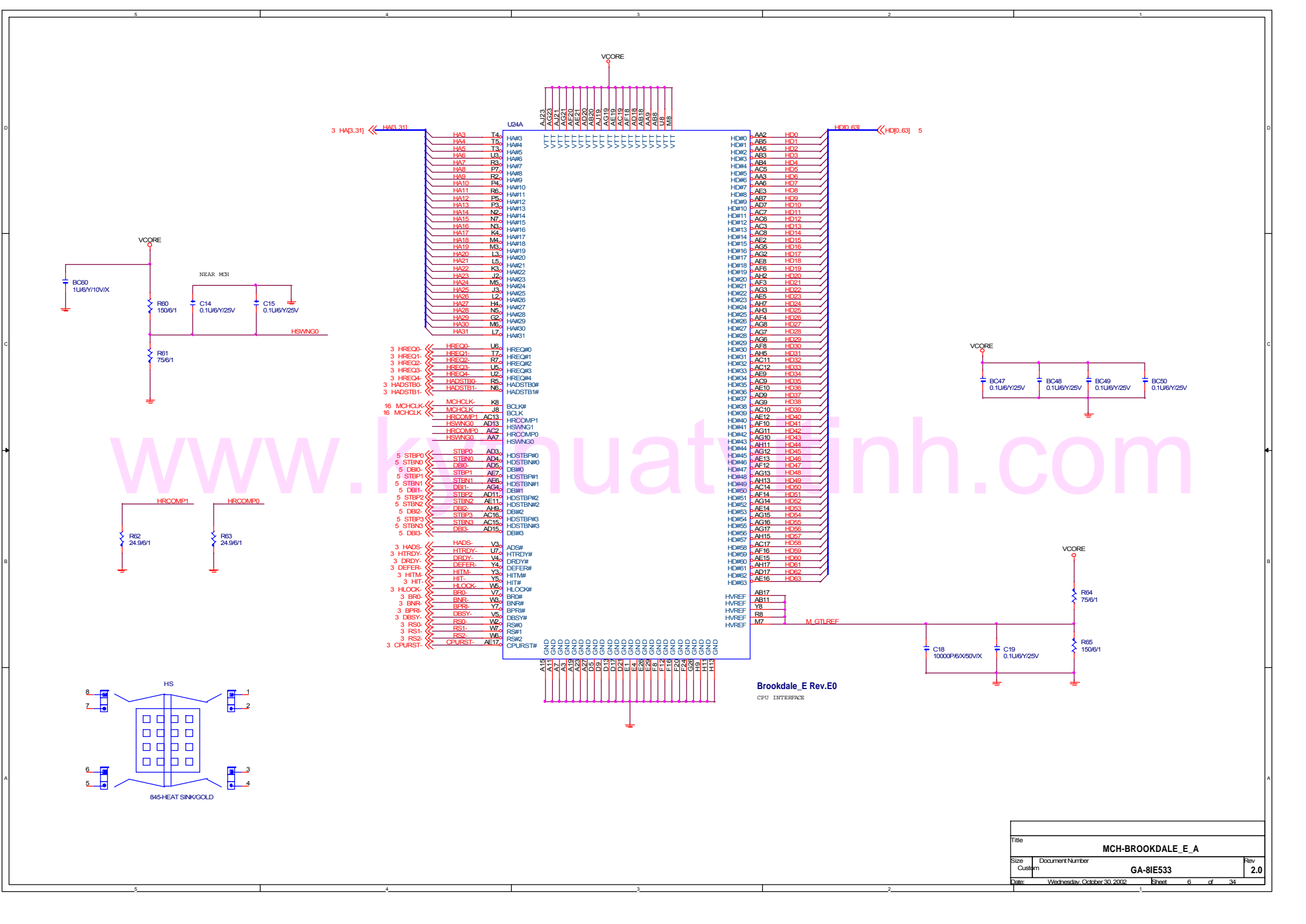

3 HA[3..31] << HA[3..31]

HD[0..63] << HD[0..63] 5

| Pin | Function | Pin | Function |
|---------|----------|----------|----------|
| HA3 | T4 | HA#3 | |
| HA4 | T5 | HA#4 | |
| HA5 | T3 | HA#5 | |
| HA6 | U3 | HA#6 | |
| HA7 | R3 | HA#7 | |
| HA8 | P7 | HA#8 | |
| HA9 | R2 | HA#9 | |
| HA10 | R5 | HA#10 | |
| HA11 | R6 | HA#11 | |
| HA12 | P5 | HA#12 | |
| HA13 | P3 | HA#13 | |
| HA14 | N2 | HA#14 | |
| HA15 | N7 | HA#15 | |
| HA16 | N3 | HA#16 | |
| HA17 | K4 | HA#17 | |
| HA18 | M5 | HA#18 | |
| HA19 | M3 | HA#19 | |
| HA20 | L3 | HA#20 | |
| HA21 | L5 | HA#21 | |
| HA22 | K3 | HA#22 | |
| HA23 | J2 | HA#23 | |
| HA24 | M2 | HA#24 | |
| HA25 | L2 | HA#25 | |
| HA26 | L4 | HA#26 | |
| HA27 | H4 | HA#27 | |
| HA28 | N5 | HA#28 | |
| HA29 | C2 | HA#29 | |
| HA30 | M6 | HA#30 | |
| HA31 | L7 | HA#31 | |
| HREC0 | U6 | HREC#0 | |
| HREC1 | T7 | HREC#1 | |
| HREC2 | R7 | HREC#2 | |
| HREC3 | U5 | HREC#3 | |
| HREC4 | U2 | HREC#4 | |
| HADSTB0 | R5 | HADSTB# | |
| HADSTB1 | N6 | HADSTB# | |
| MCHCLK | K8 | BCLK# | |
| MCHCLK | J8 | BCLK | |
| HRCOMP1 | AC13 | HRCOMP# | |
| HSWING0 | AD13 | HSWING# | |
| HSWING0 | A7 | HSWING0 | |
| STBP0 | AD3 | HDSTBP#0 | |
| STBN0 | AD4 | HDSTBN#0 | |
| DB0 | AD5 | DB#0 | |
| STBP1 | AE2 | HDSTBP#1 | |
| STBN1 | AE3 | HDSTBN#1 | |
| DB1 | AC4 | DB#1 | |
| DBH1 | | DB#1 | |
| STBP2 | AD11 | HDSTBP#2 | |
| STBN2 | AE10 | HDSTBN#2 | |
| DB2 | AH5 | DB#2 | |
| STBP3 | AC16 | HDSTBP#3 | |
| STBN3 | AC18 | HDSTBN#3 | |
| DB3 | AD15 | DB#3 | |
| HADS | V3 | ADG# | |
| HTRDY | U7 | HTRDY# | |
| DRDY | V5 | DRDY# | |
| DEFER | Y4 | DEFER# | |
| HITM | Y3 | HITM# | |
| HIT | Y8 | HIT# | |
| HLOCK | W5 | HLOCK# | |
| BR0 | V7 | BR# | |
| BNR | W6 | BNR# | |
| BPR | Y7 | BPR# | |
| BPR | Y5 | BPR# | |
| DBSY | V6 | DBSY# | |
| RS0 | W2 | RS#0 | |
| RS1 | W7 | RS#1 | |
| RS2 | W6 | RS#2 | |
| CPURST | AE17 | CPURST# | |

Brookdale_E Rev.00
CPU INTERFACE

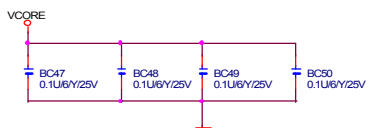
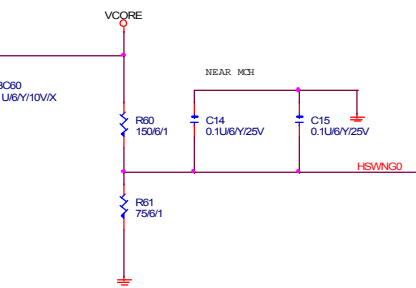

www.knuat.inh.com

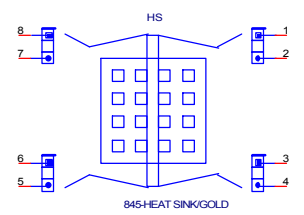

| | | | |
|--------|-----------------------------|-------|-------------------|
| Title | | | MCH-BROOKDALE_E_A |
| Size | Document Number | Rev | 2.0 |
| Custom | GA-8IE533 | | |
| Date: | Wednesday, October 30, 2002 | Sheet | 6 of 34 |

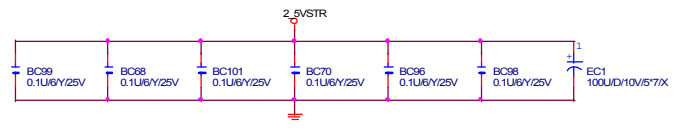
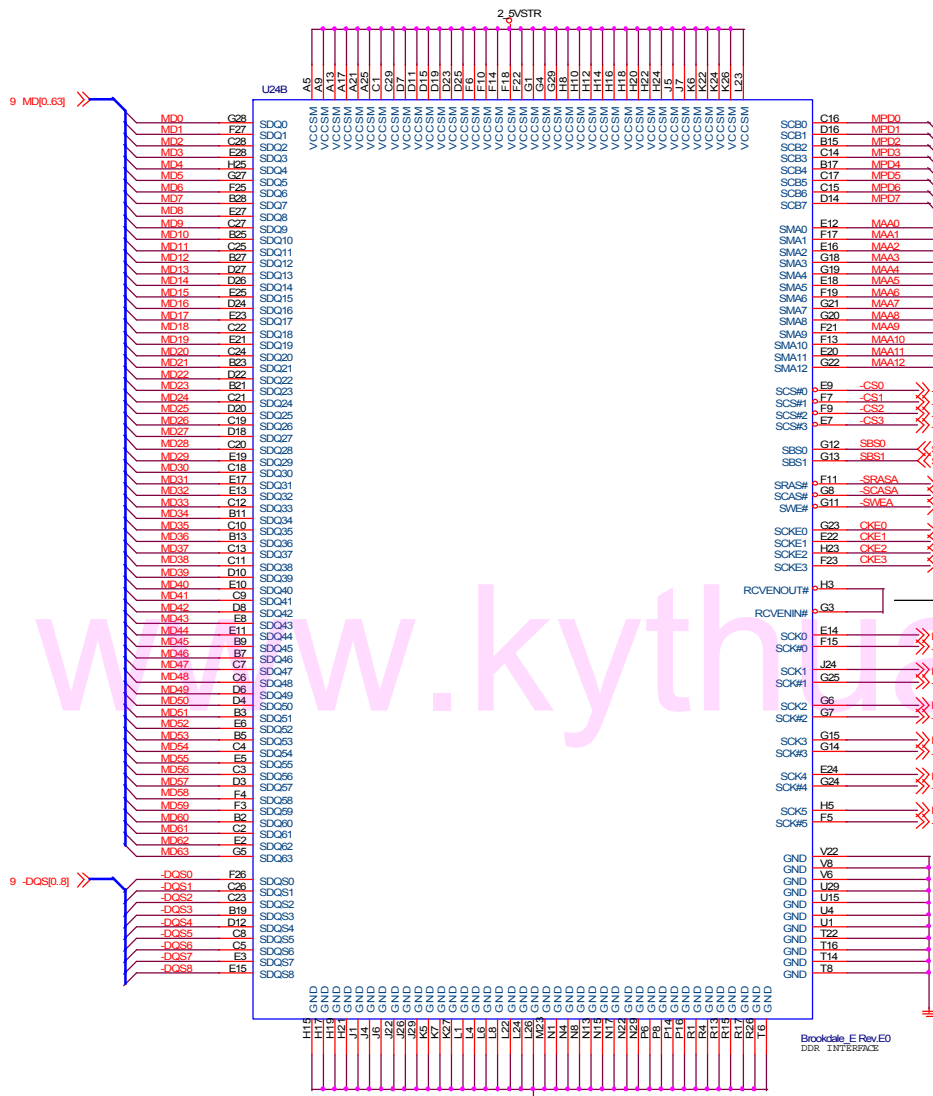

www.kything.com

| | | | |
|--------|-----------------------------|-------|-------------------|
| Title | | | MCH-BROOKDALE_E_B |
| Size | Document Number | Rev | 2.0 |
| Custom | GA-8IE533 | | |
| Date: | Wednesday, October 30, 2002 | Sheet | 7 of 34 |

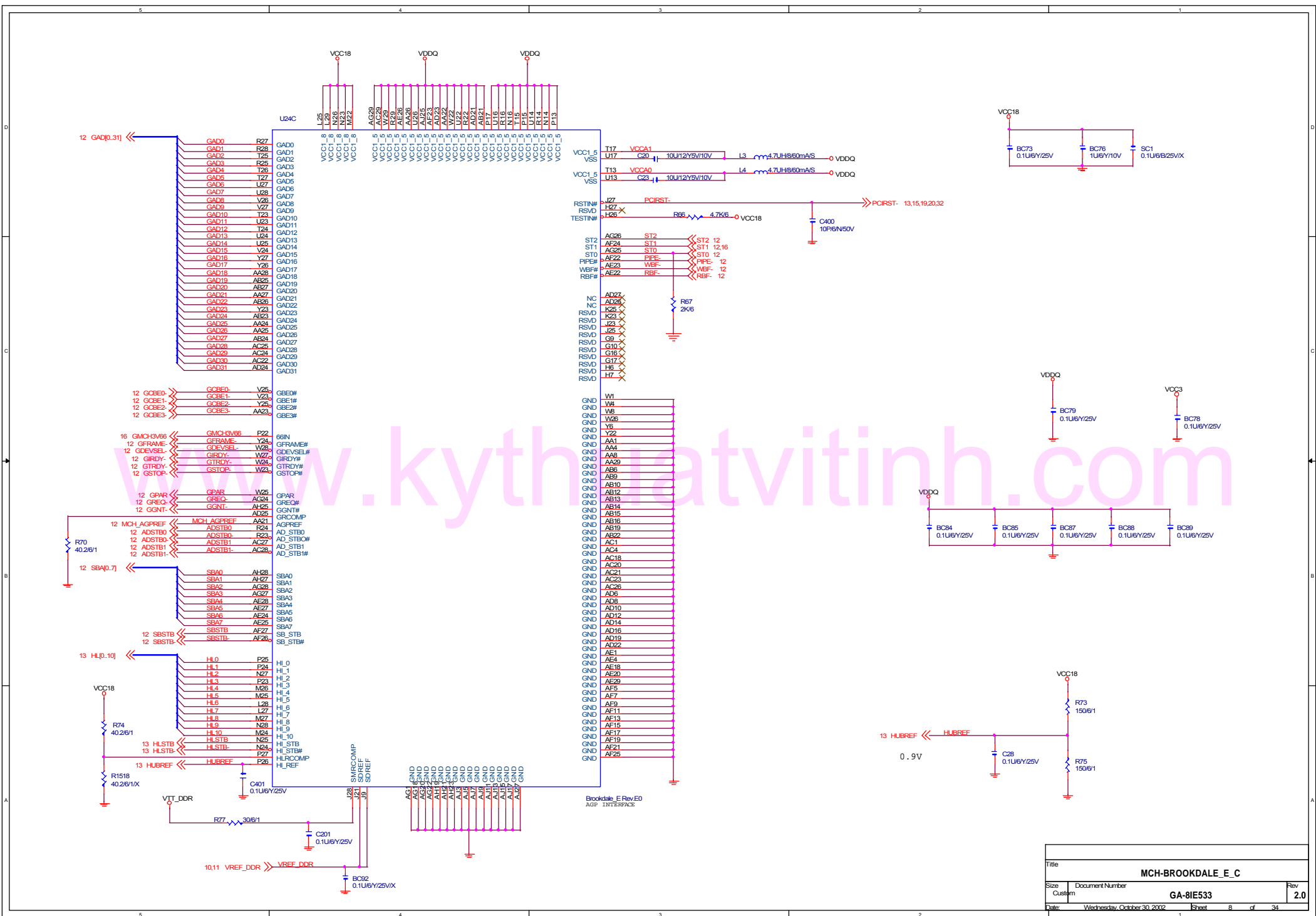

| | | | | | |
|--------|-----------------------------|-------|-------------------|----|----|
| Title | | | MCH-BROOKDALE_E_C | | |
| Size | Document Number | Rev | | | |
| Custom | GA-8IE533 | 2.0 | | | |
| Date: | Wednesday, October 30, 2002 | Sheet | 8 | of | 34 |

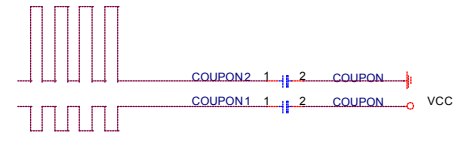
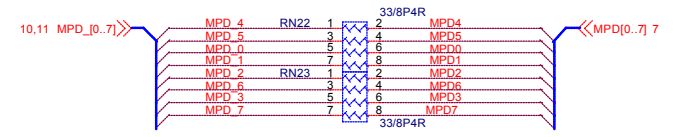
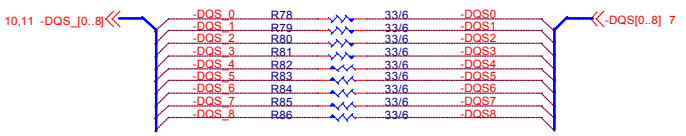
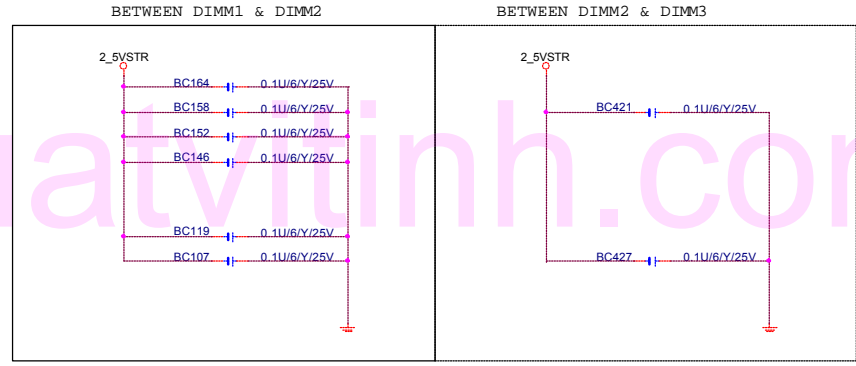
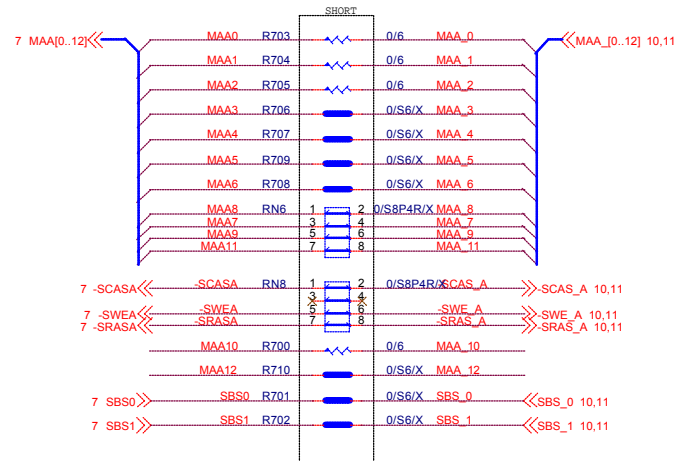
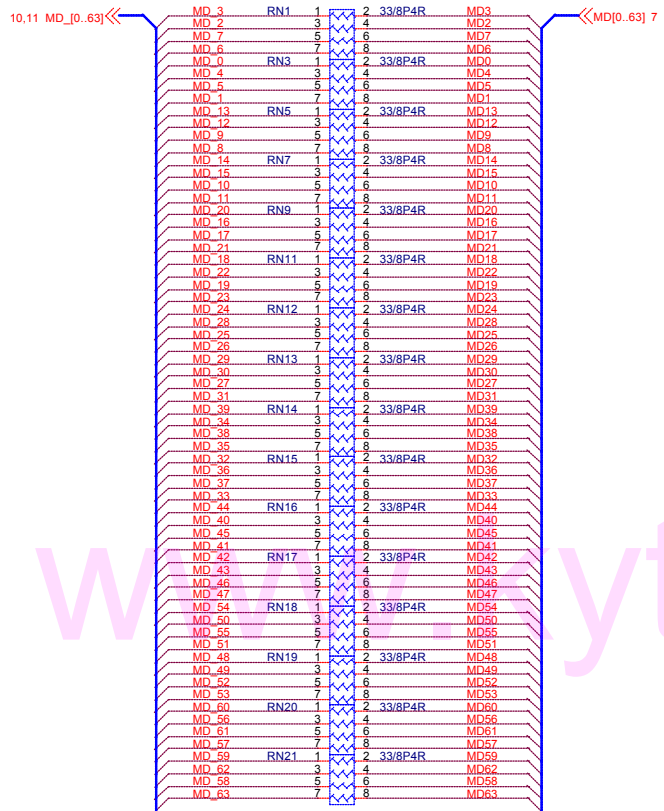

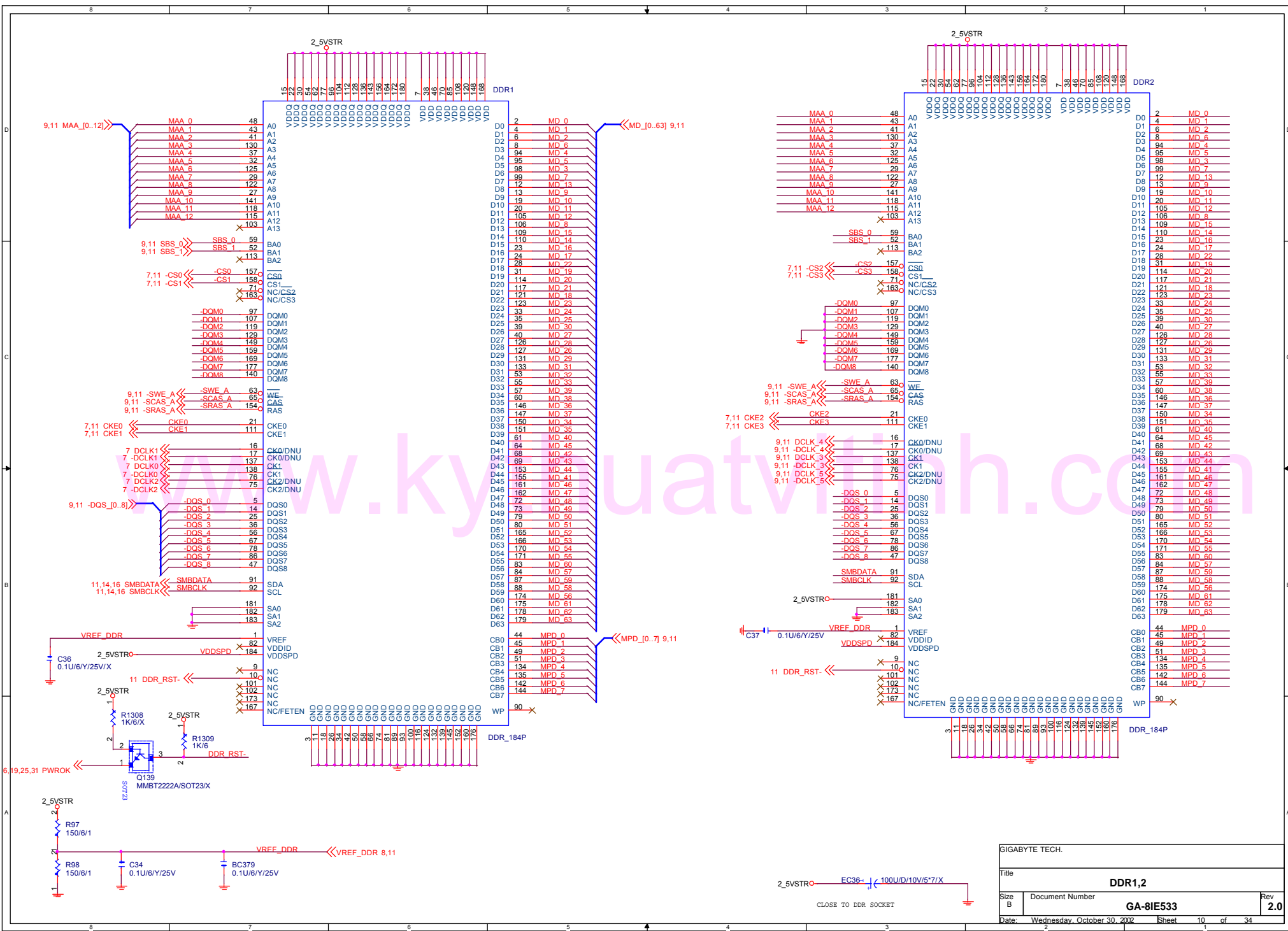

| | |
|-----------------------------------|---------------------------|
| GIGABYTE TECH. | |
| Title | DDR1,2 |
| Size B | Document Number GA-8IE533 |
| Date: Wednesday, October 30, 2002 | Sheet 10 of 34 |

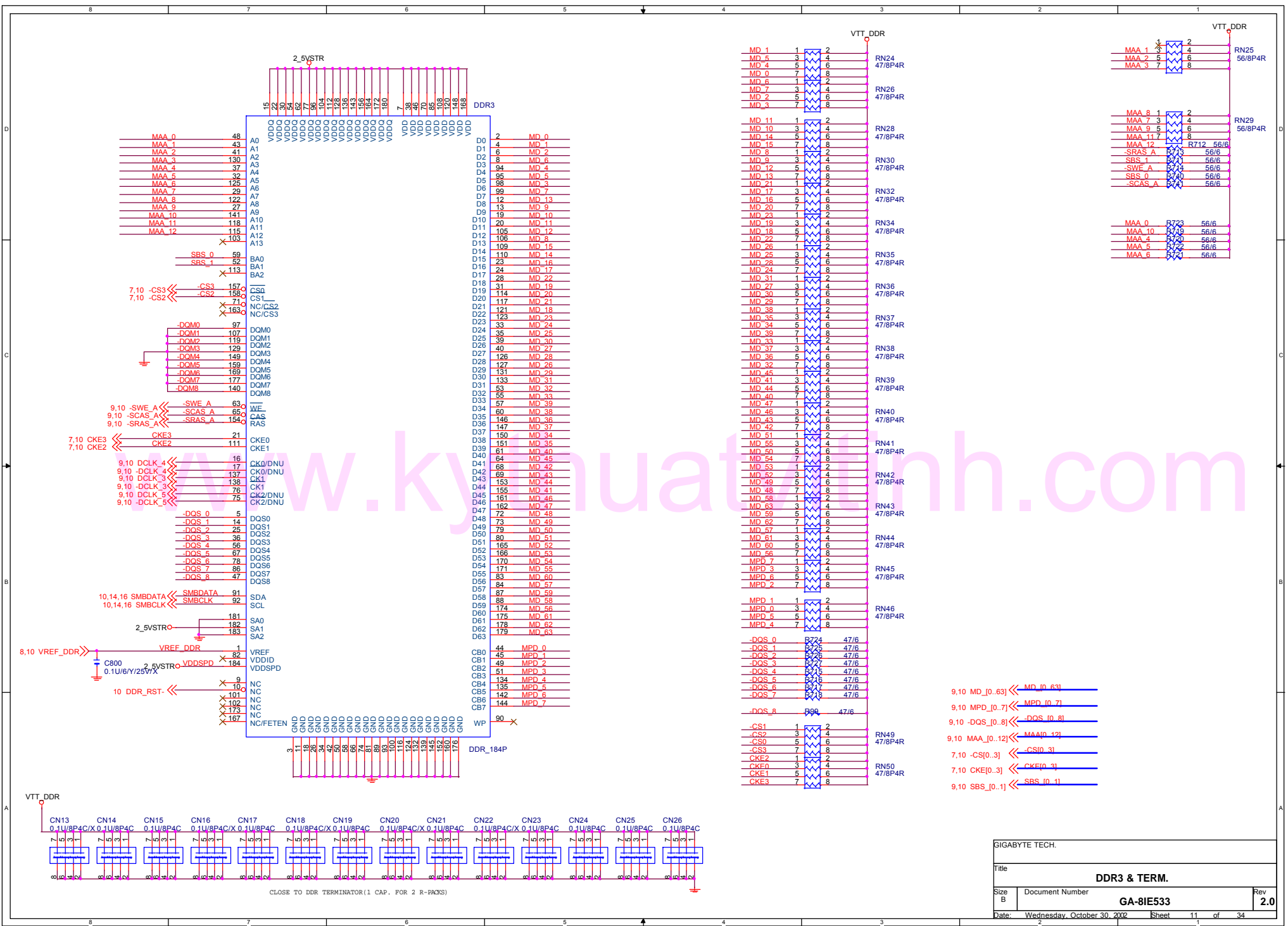

| | |
|-----------------------------------|-----------------------------------|
| GIGABYTE TECH. | |
| Title: DDR3 & TERM. | |
| Size B | Document Number: GA-8IE533 |
| Date: Wednesday, October 30, 2002 | Rev: 2.0 |
| Sheet 11 | of 34 |

4X only

8 SBA[0..7] << SBA[0..7]
8.16 ST[0..2] << ST[0..2]
8 GAD[0..31] << GAD[0..31]

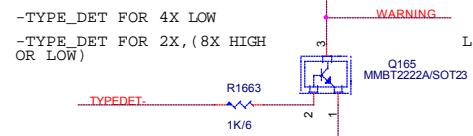
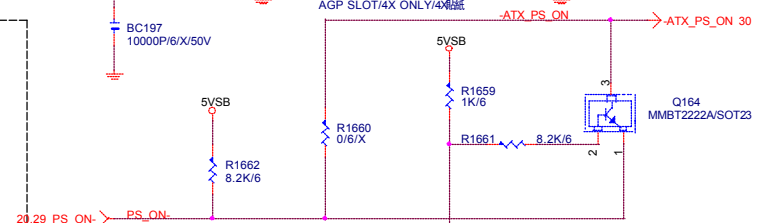
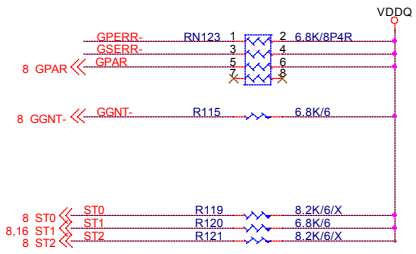
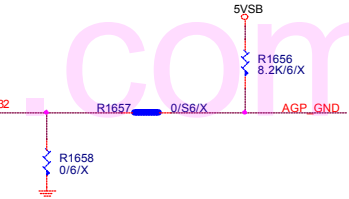
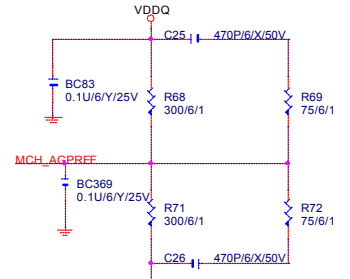
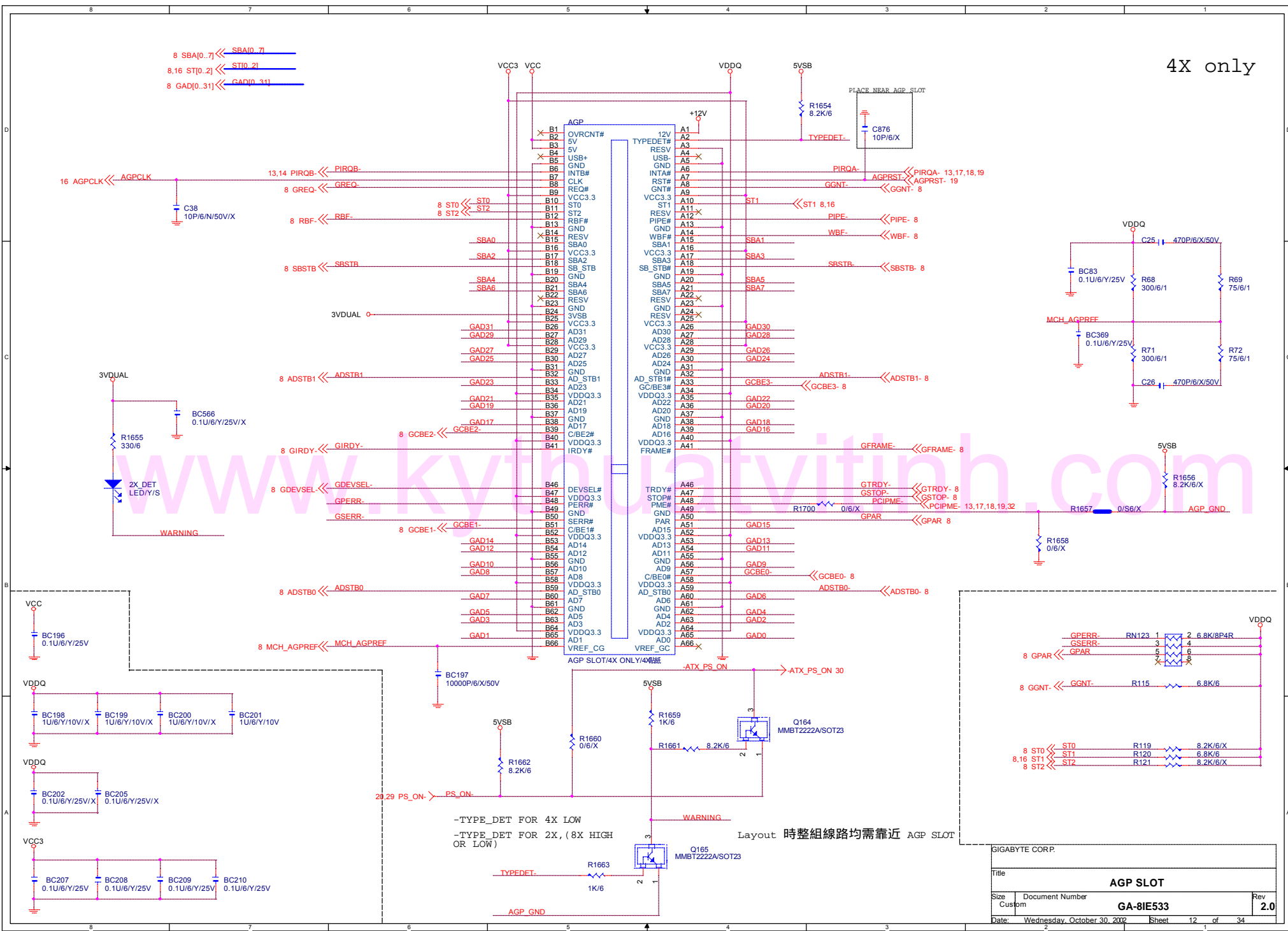

Layout 時整組線路均需靠近 AGP SLOT

| | | | |
|----------------|-----------------------------|----------|----------|
| GIGABYTE CORP. | | | |
| Title | | AGP SLOT | |
| Size | Document Number | Rev | 2.0 |
| Custom | GA-8IE533 | | |
| Date: | Wednesday, October 30, 2002 | Sheet | 12 of 34 |

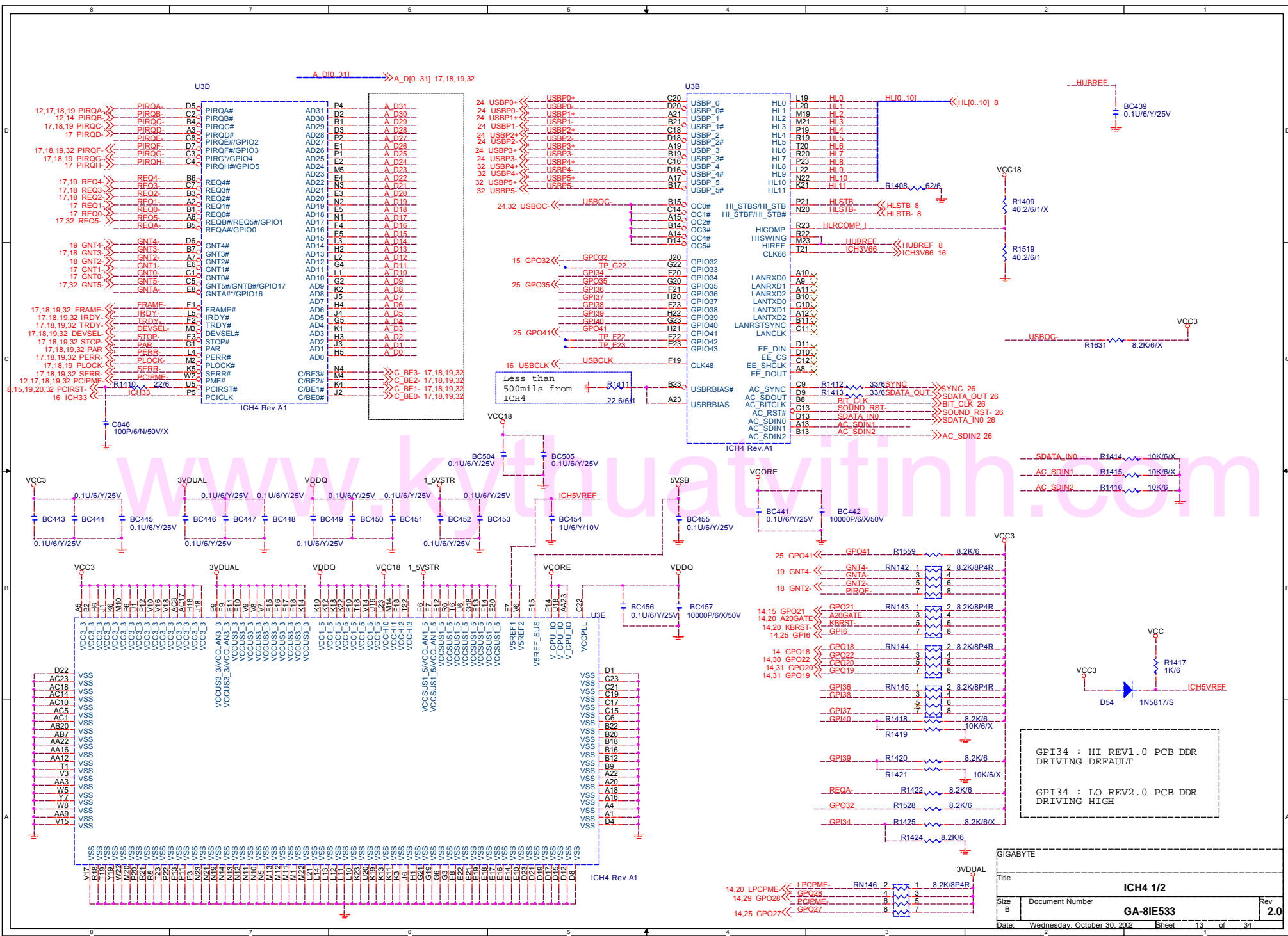

GPI34 : HI REV1.0 PCB DDR
DRIVING DEFAULT

GPI34 : LO REV2.0 PCB DDR
DRIVING HIGH

| | |
|----------|-----------------------------|
| GIGABYTE | |
| Title | ICH4 1/2 |
| Size B | Document Number |
| | GA-8IE533 |
| Date: | Wednesday, October 30, 2002 |
| Sheet | 13 of 34 |
| Rev | 2.0 |

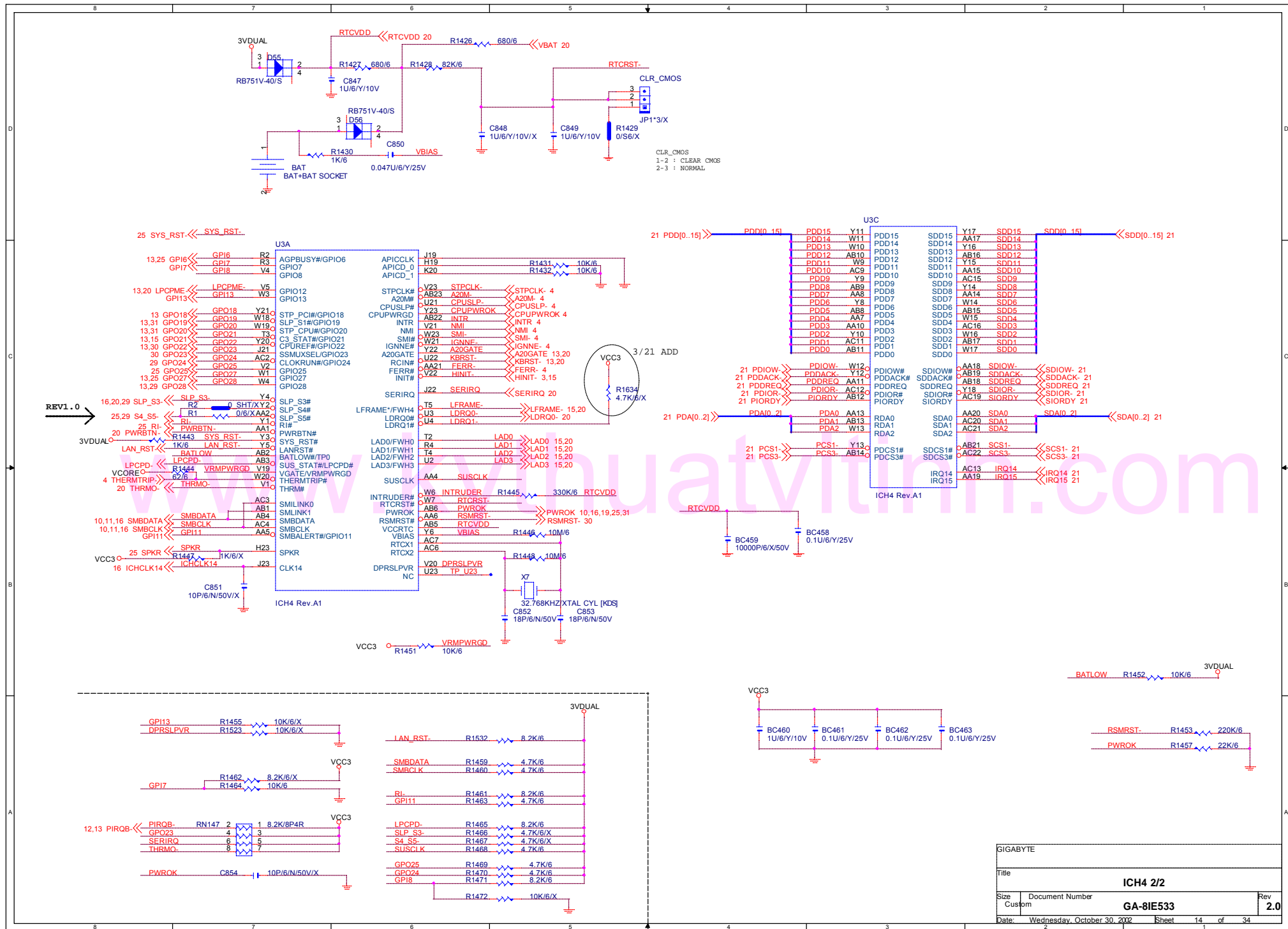

| | | | |
|----------|-----------------------------|----------|----------|
| GIGABYTE | | | |
| Title | | ICH4 2/2 | |
| Size | Document Number | Rev | |
| Custom | GA-8IE533 | 2.0 | |
| Date: | Wednesday, October 30, 2002 | Sheet | 14 of 34 |

2002/04/15 MODIFY WRITE PROTECT

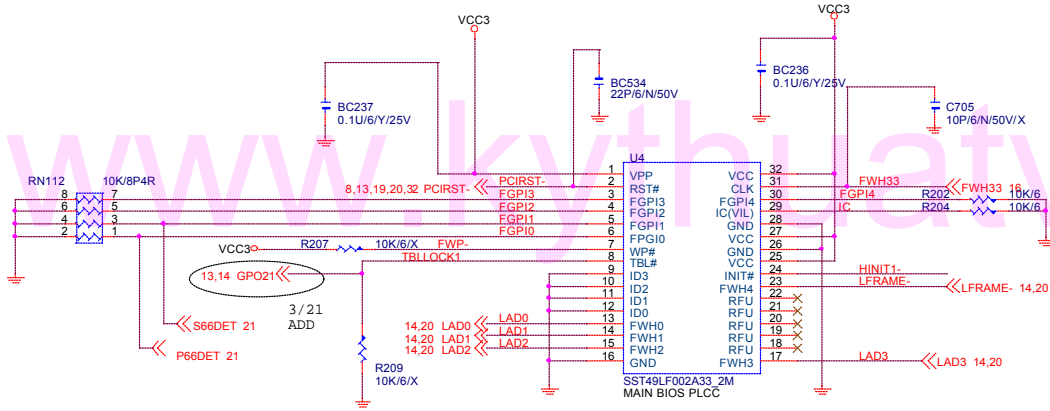
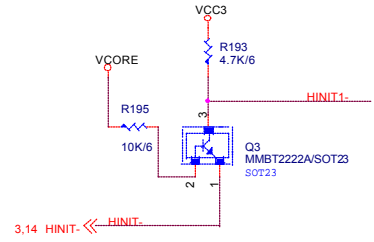
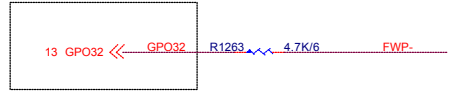

| | | | |
|----------------|-----------------------------|-----------|---------|
| GIGABYTE CORP. | | | |
| Title | | | |
| FHW | | | |
| Size B | Document Number | GA-8IE533 | Rev 2.0 |
| Date: | Wednesday, October 30, 2002 | Sheet 15 | of 34 |

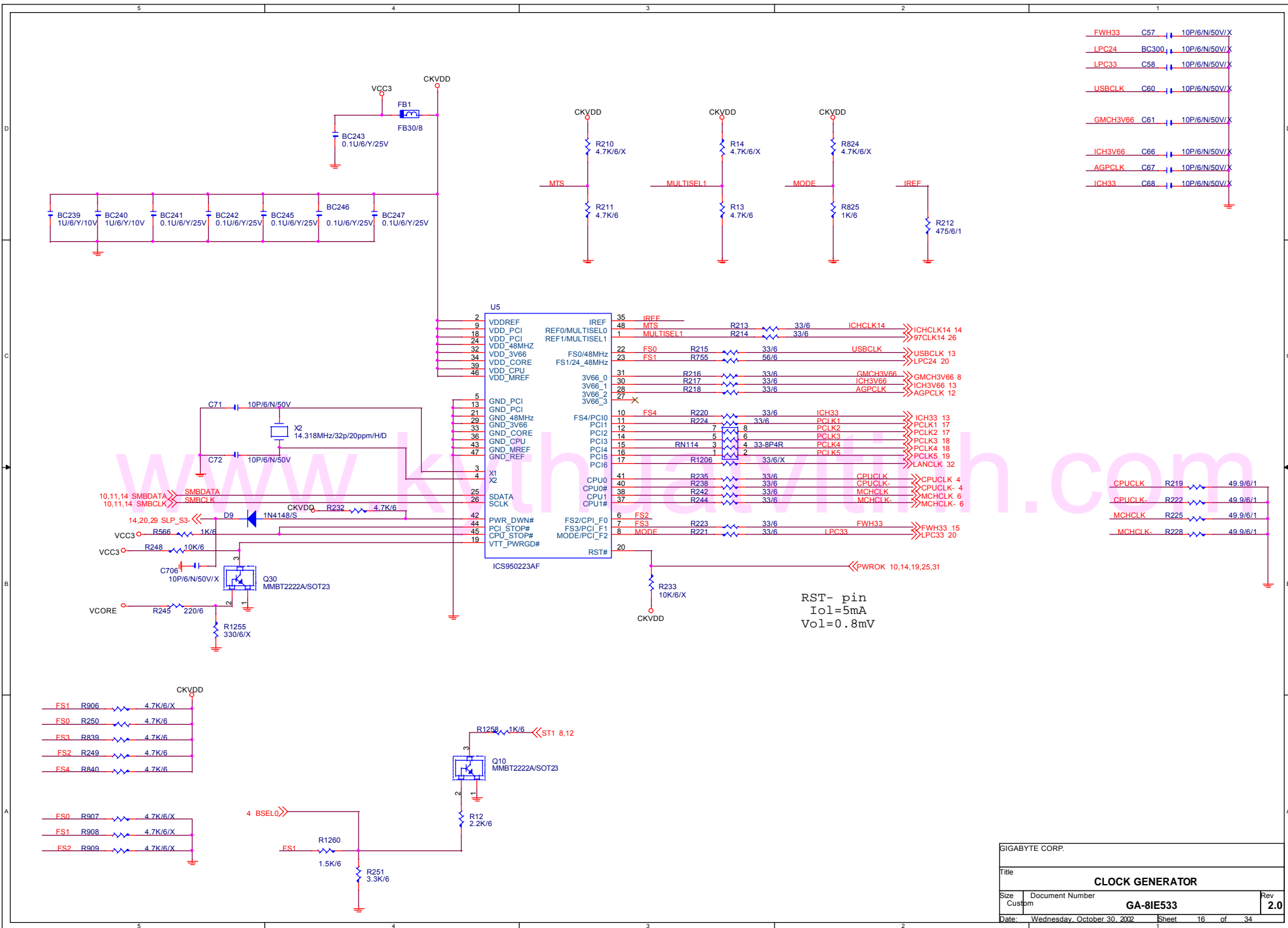

| | | |
|------------------------|-----------------------------|----------------|
| GIGABYTE CORP. | | |
| Title | | |
| CLOCK GENERATOR | | |
| Size | Document Number | Rev |
| Custom | GA-8IE533 | 2.0 |
| Date: | Wednesday, October 30, 2002 | Sheet 16 of 34 |

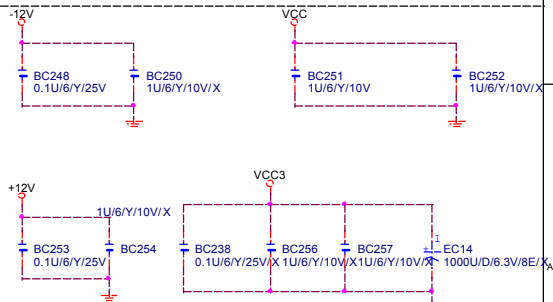
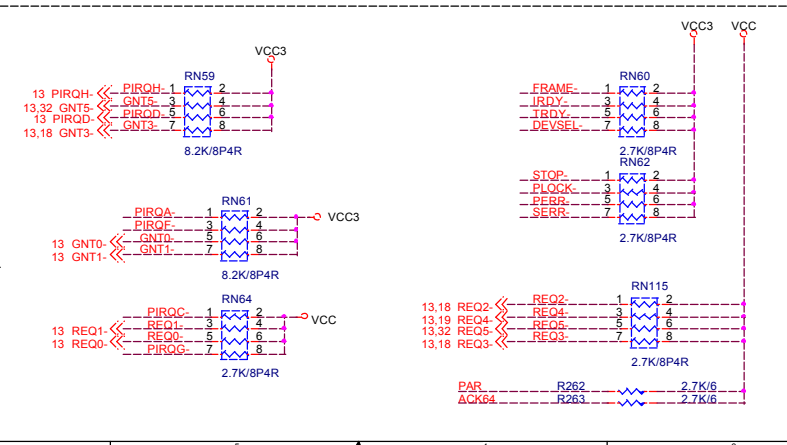
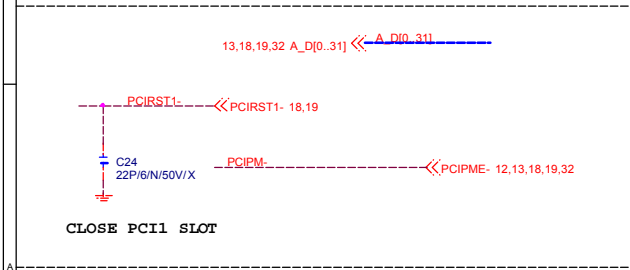
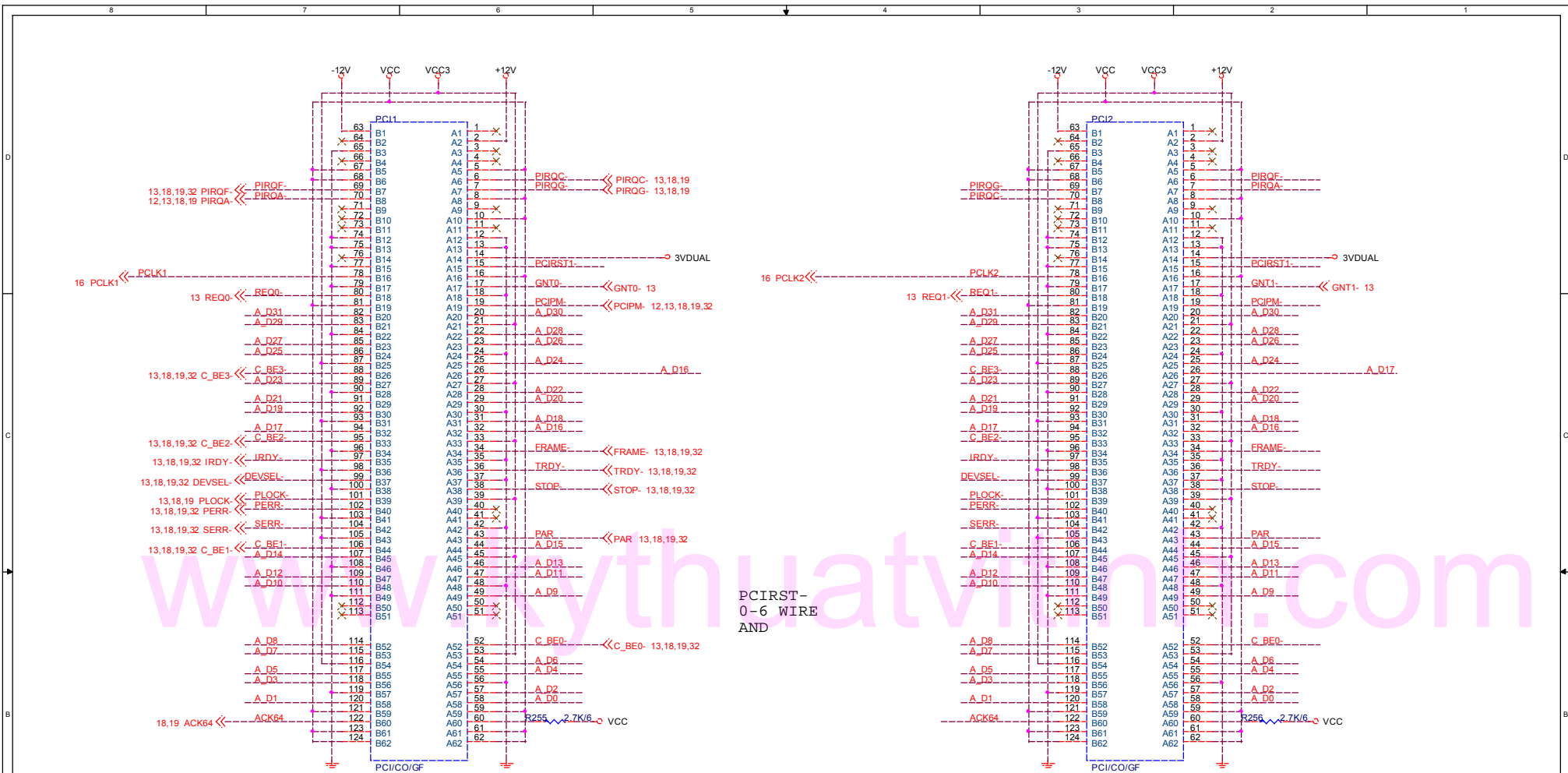

| | | |
|-----------------------------------|----------------------------------|----------------|
| GIGABYTE CORP. | | |
| Title PCI SLOT 1/2 | | |
| Size B | Document Number GA-8IE533 | Rev 2.0 |
| Date: Wednesday, October 30, 2002 | Sheet 17 | of 34 |

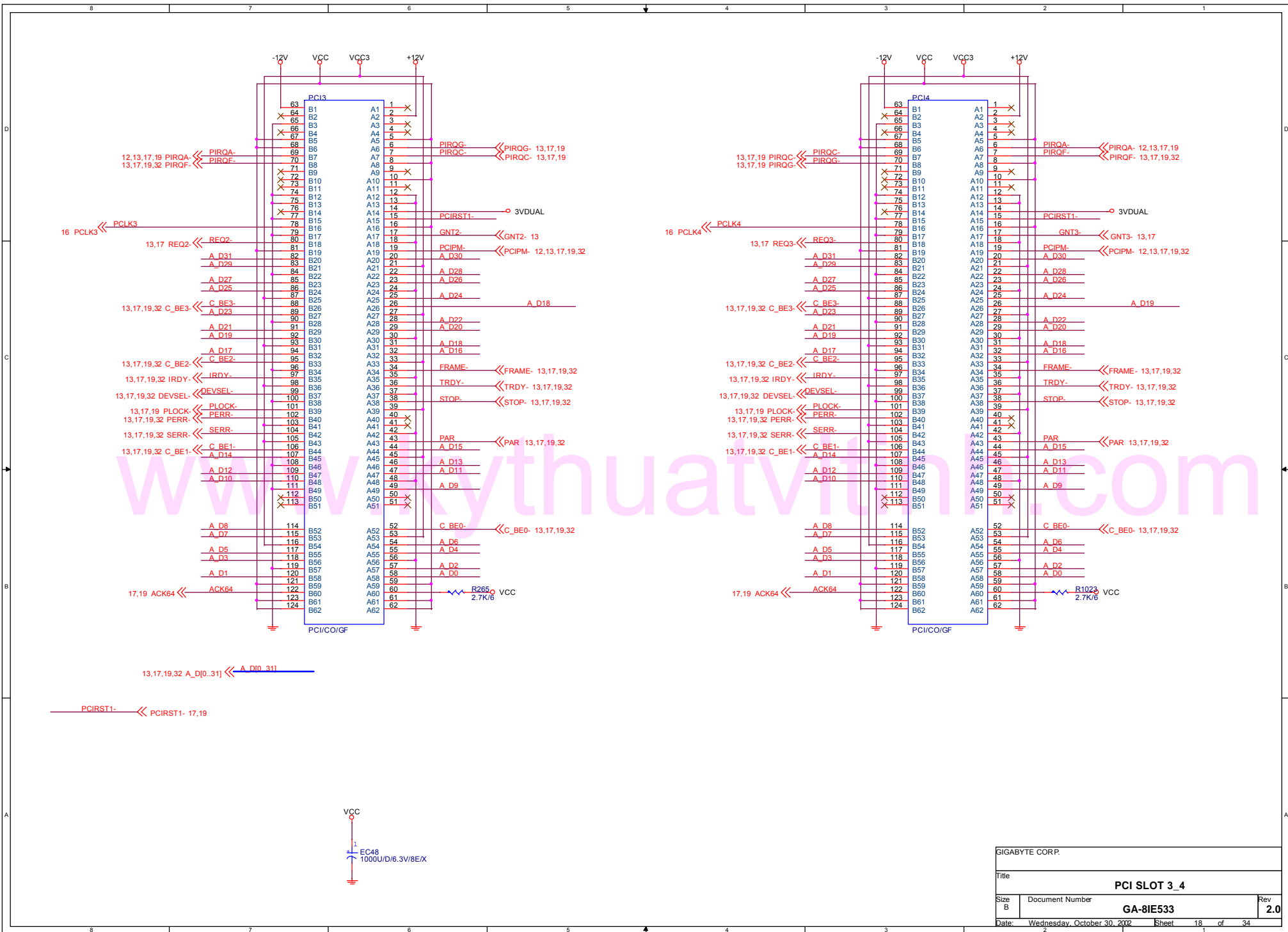

| | | | |
|---------------------------|-----------------------------|------------------|----------------|
| GIGABYTE CORP. | | | |
| Title PCI SLOT 3_4 | | | |
| Size B | Document Number | GA-8IE533 | Rev 2.0 |
| Date: | Wednesday, October 30, 2002 | Sheet 18 | of 34 |

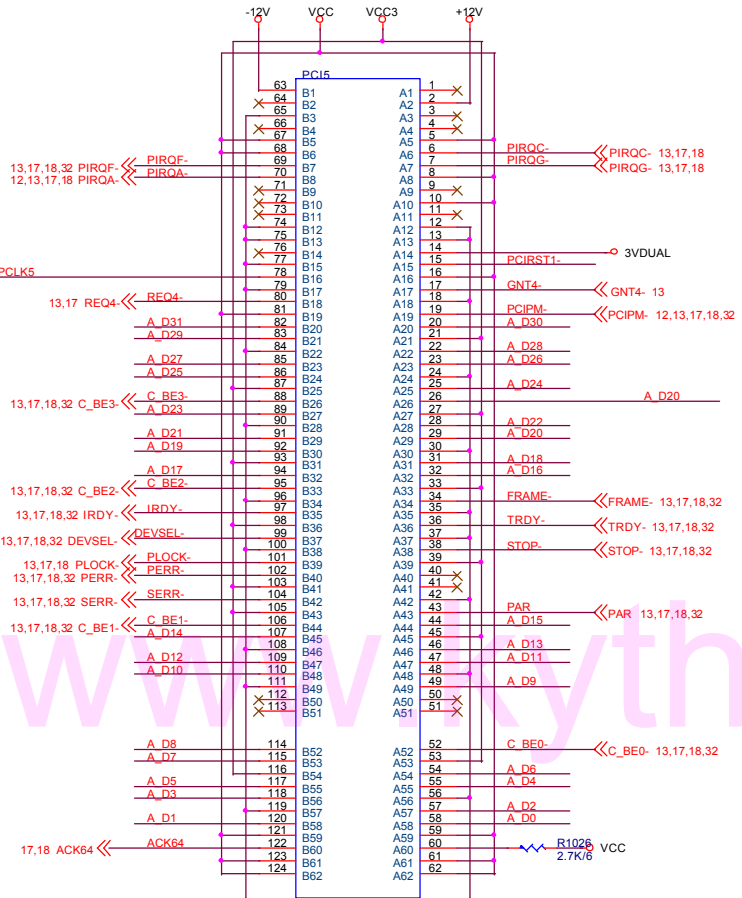

www.lythuatvithinh.com

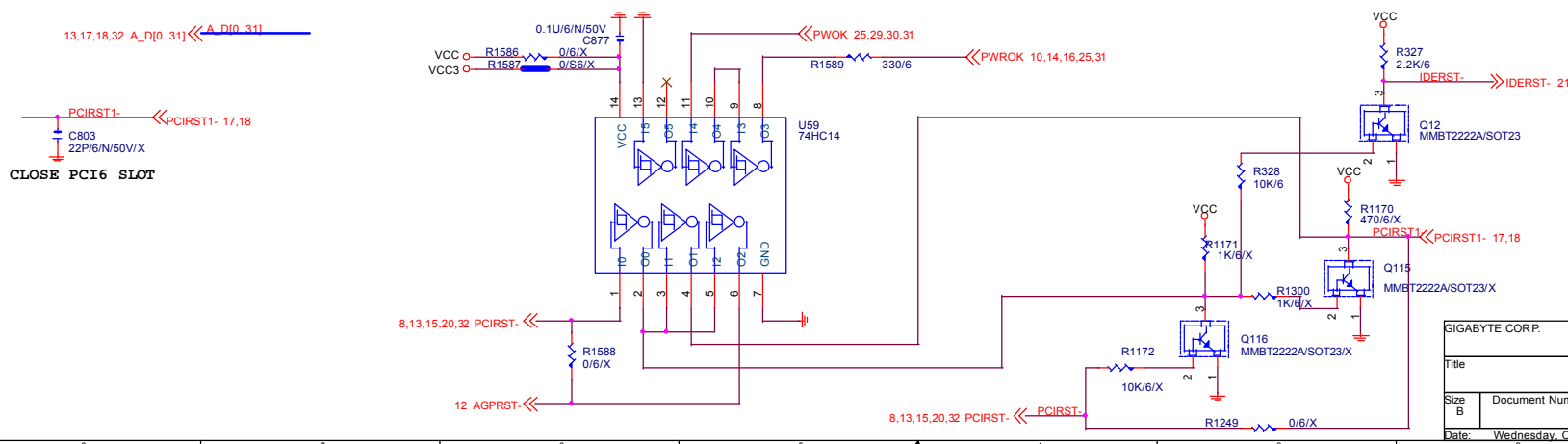

| | | |
|-------------------|-----------------------------|----------------|
| GIGABYTE CORP. | | |
| Title | | |
| PCI SLOT 5 | | |
| Size B | Document Number | Rev |
| | GA-8IE533 | 2.0 |
| Date: | Wednesday, October 30, 2002 | Sheet 19 of 34 |

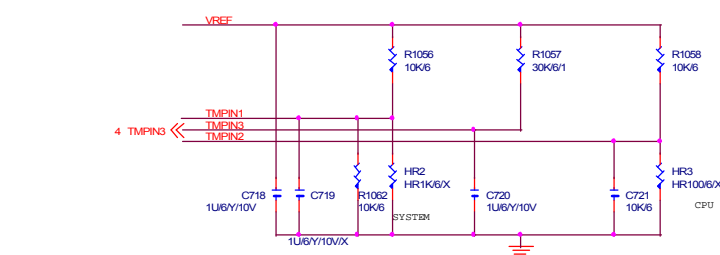
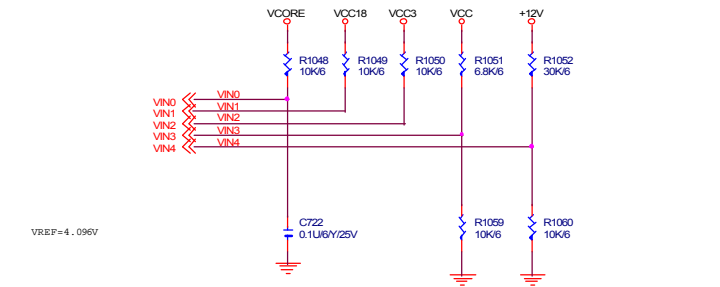
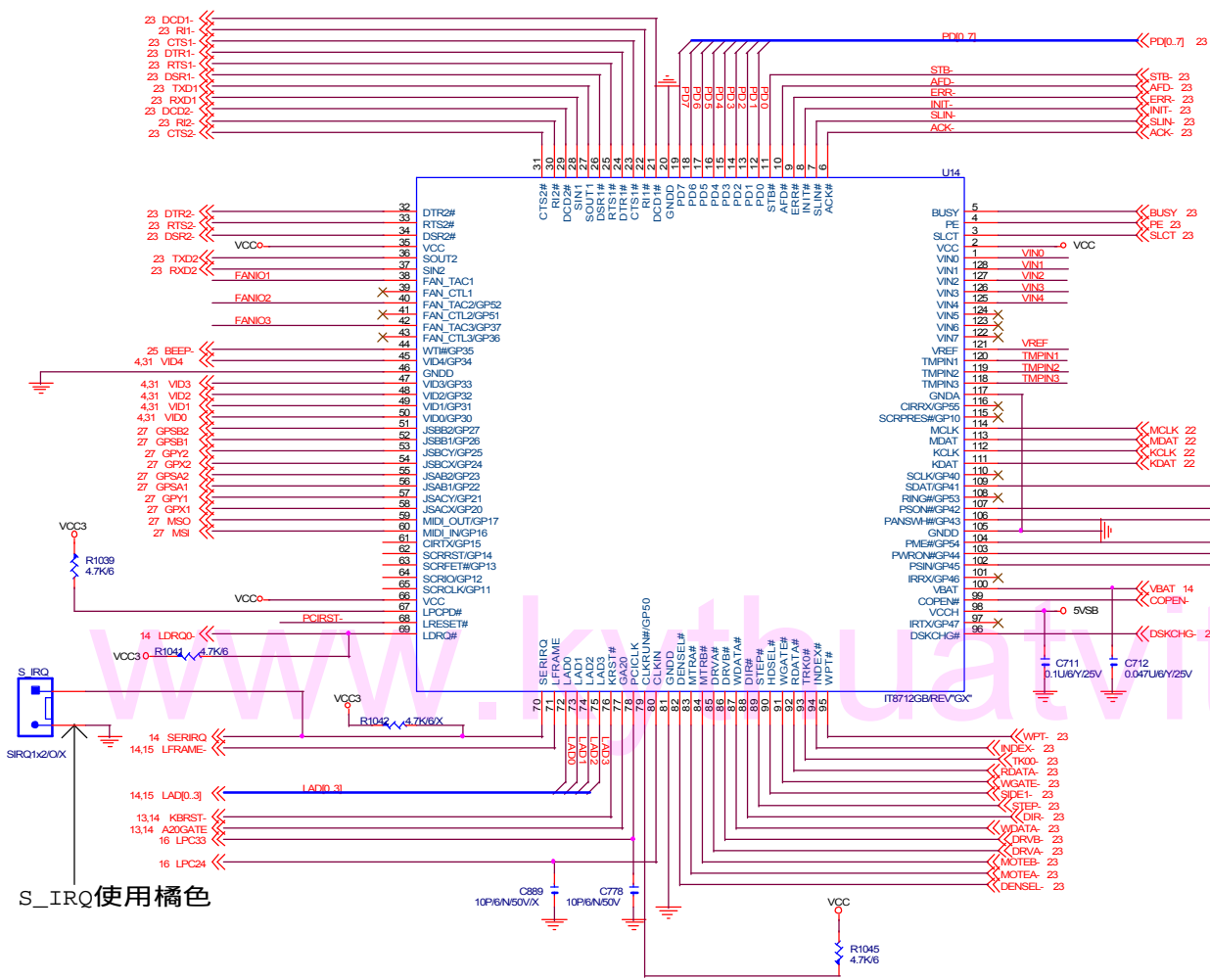

S_IRQ使用橘色

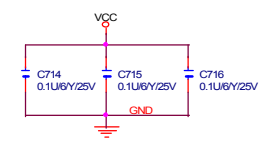
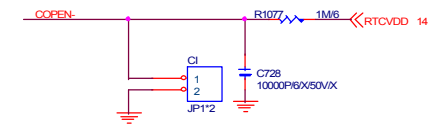
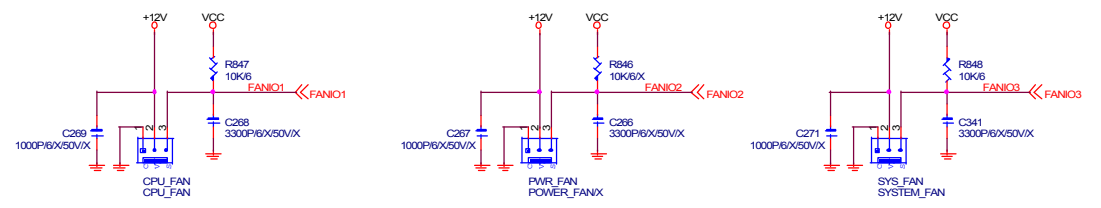

| | | | |
|----------------|-----------------------------|-------|----------|
| GIGABYTE CORP. | | | |
| Title | | | |
| ITE LPC I/O | | | |
| Size | Document Number | Rev | |
| Custom | GA-8IE533 | 2.0 | |
| Date: | Wednesday, October 30, 2002 | Sheet | 20 of 34 |

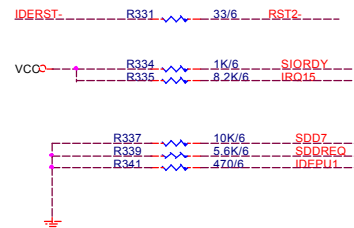
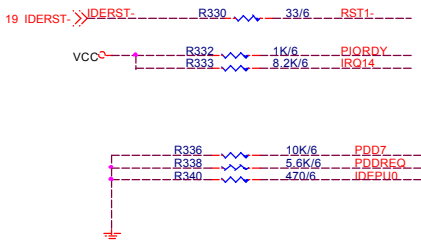
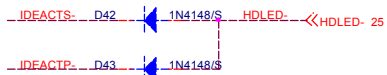

www.kythuatchinh.com

PRIMARY IDE CONNECTOR

SECONDARY IDE CONNECTOR

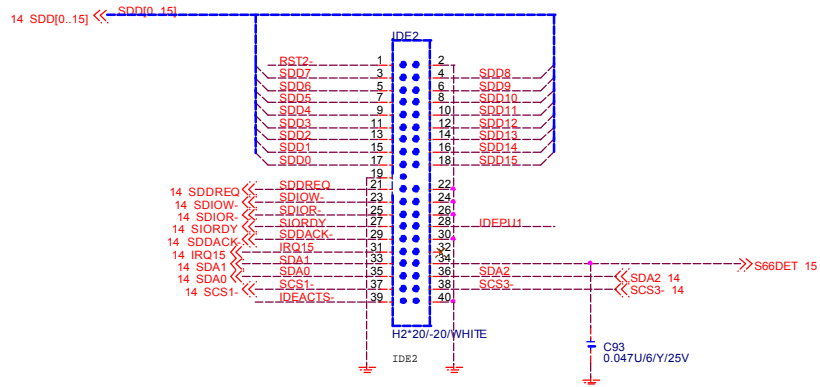
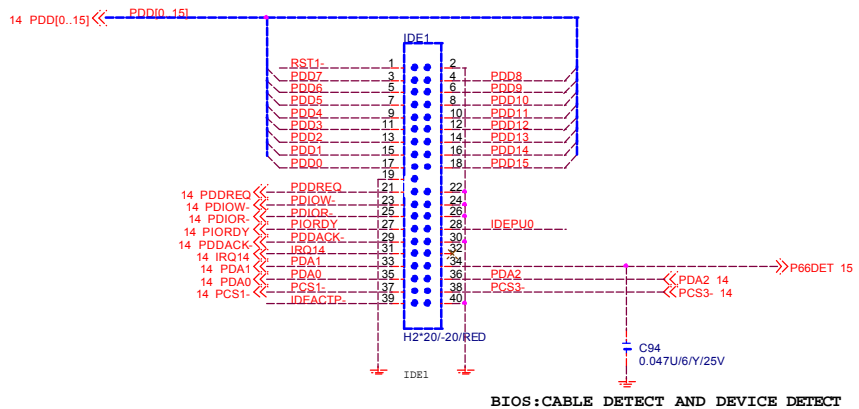

BIOS:CABLE DETECT AND DEVICE DETECT

| | | | |
|----------------------|-----------------------------|-----------|---------|
| GIGABYTE CORP. | | | |
| Title: IDE CONNECTOR | | | |
| Size B | Document Number | GA-8IE533 | Rev 2.0 |
| Date: | Wednesday, October 30, 2002 | Sheet 21 | of 34 |

模組化線路

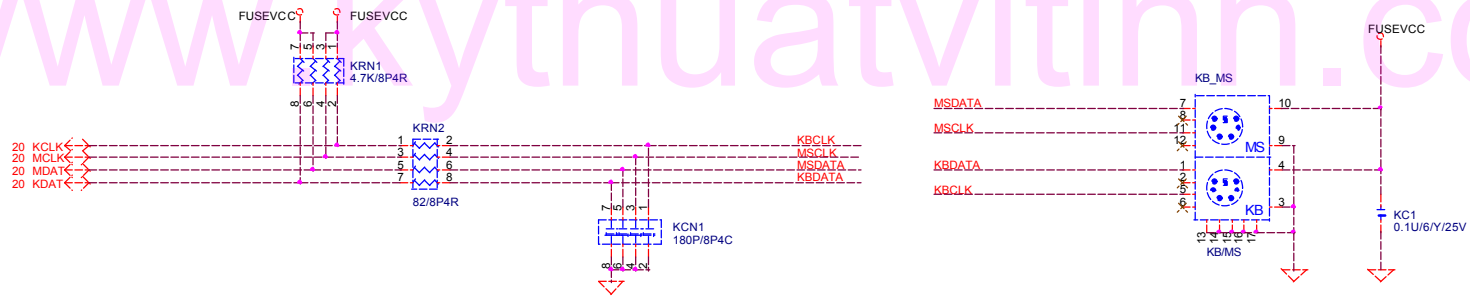
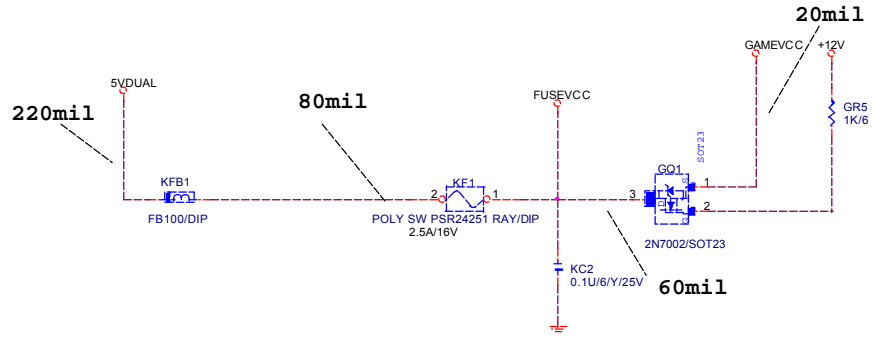

| | | | |
|---------------------|-----------------------------|-----------|----------|
| GIGABYTE CORP. | | | |
| Title | | | |
| KB & PS2 MOUSE & IR | | | |
| Size | Document Number | GA-8IE533 | Rev |
| B | | | 2.0 |
| Date: | Wednesday, October 30, 2002 | Sheet | 22 of 34 |

COMA

模組化線路

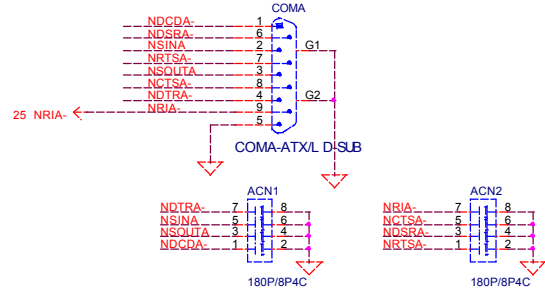
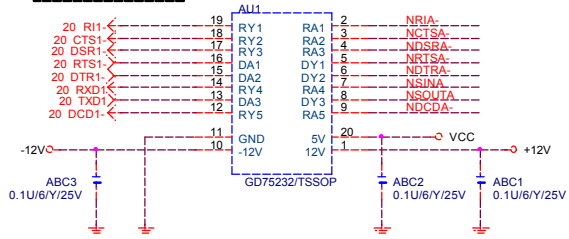

FLOPPY

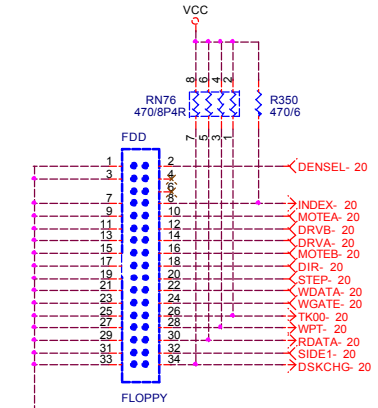

COMB

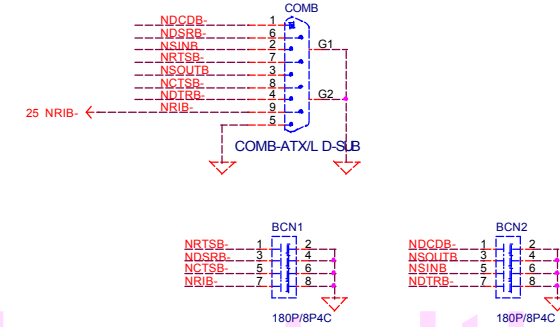
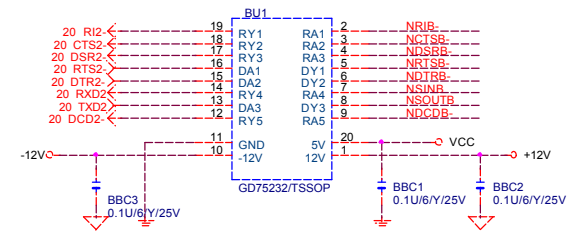

PRT PORT

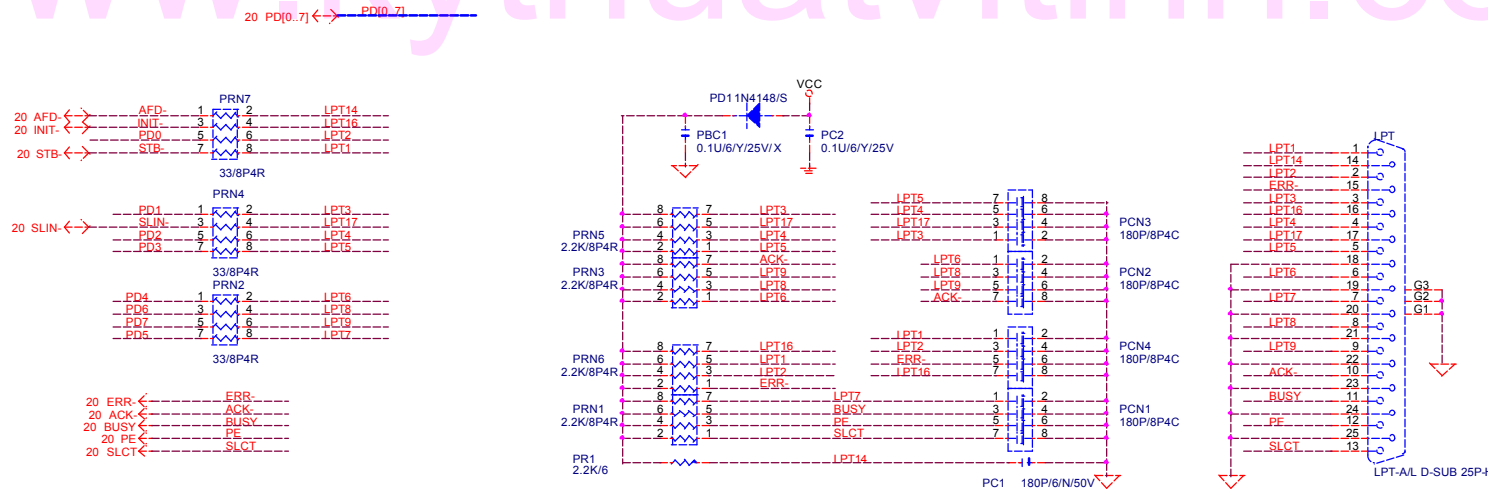

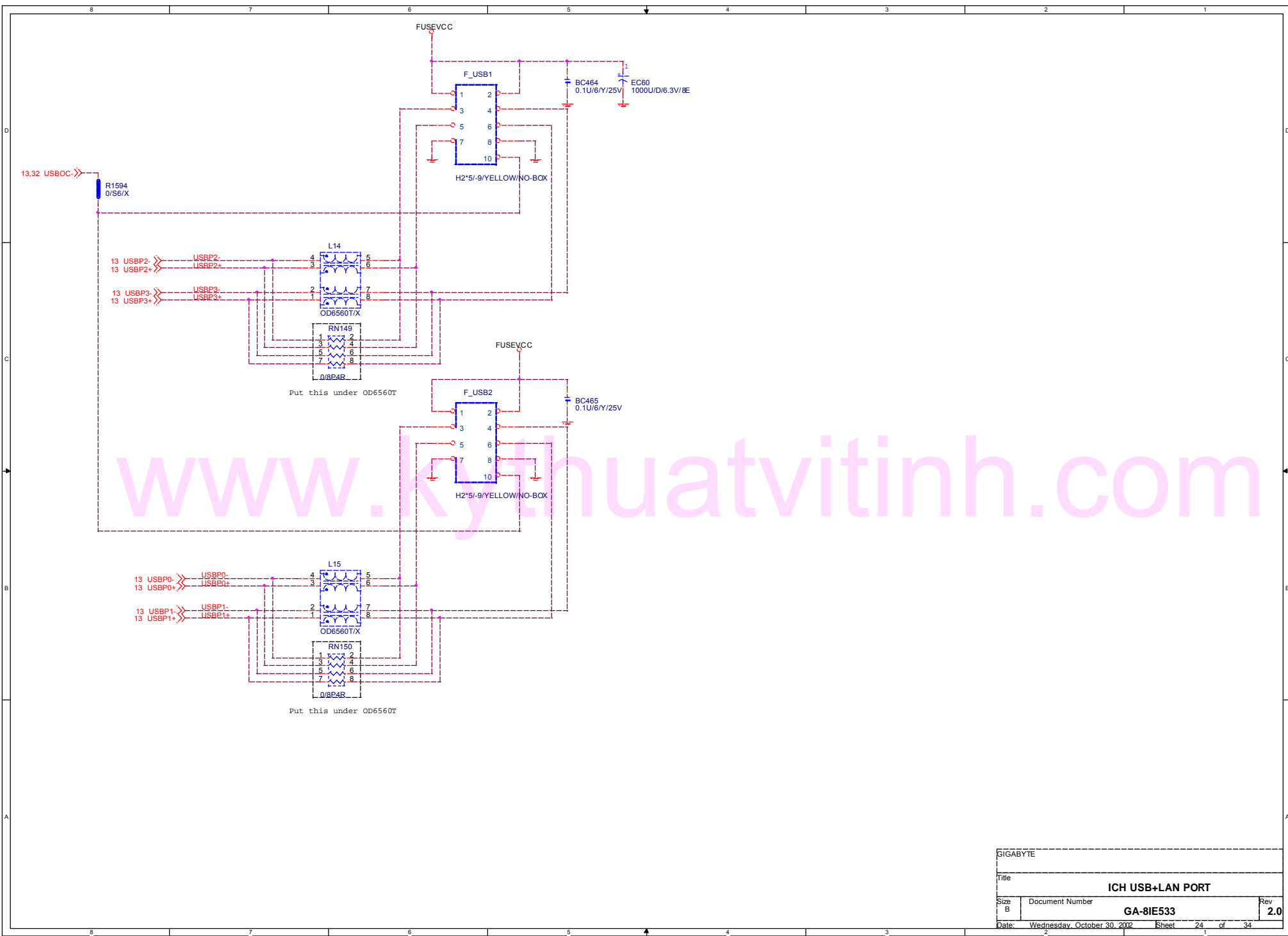

| | | | |
|-------------------------|-----------------------------|-----------|------------|
| GIGABYTE | | | |
| Title | | | |
| ICH USB+LAN PORT | | | |
| Size | Document Number | GA-8IE533 | Rev |
| B | | | 2.0 |
| Date: | Wednesday, October 30, 2002 | Sheet | 24 of 34 |

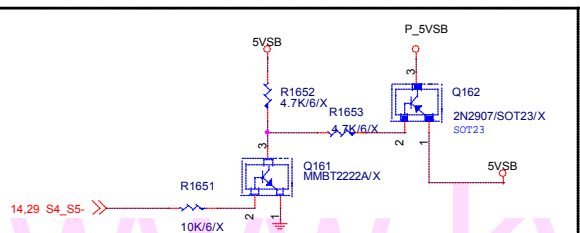
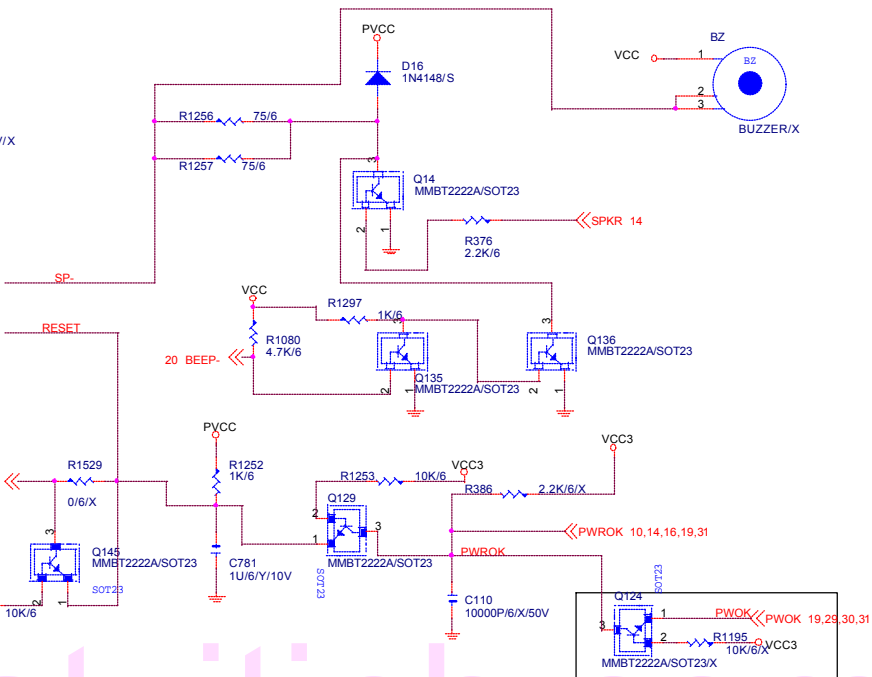
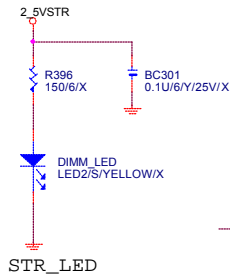
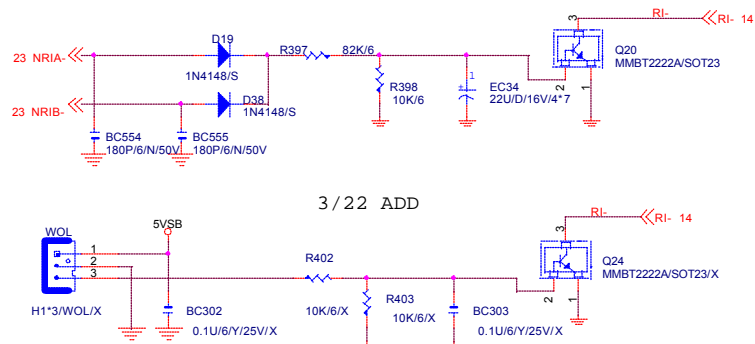

3 PIN POWER LED

| | | |
|-----------|---|------|
| PWR_LED | 1 | MPD+ |
| | 2 | MPD- |
| | 3 | MPD- |
| P_LED_1X3 | | |

States for green LED

| LED States | ACPI States | GPO28 |
|------------|-------------|-------|
| ON | S1, S3 | 0 |
| OFF | S0, S5 | 1 |

NO1 GPO35 只需在S1 PROGRAMMING LOW

States for a single-color power LED

| LED States | ACPI States | GPO25 | GPO27 | GPO35 |
|----------------|--------------------|-------|-------|-------|
| OFF | S1, S3, S5 | 1 | 1 | NO1 |
| Steady Green | S0 | 0 | 1 | 0 |
| Blinking Green | S0(message waiting | 0 | B | 0 |

States for a dual-color power LED

| LED States | ACPI States | GPO25 | GPO27 | GPO35 |
|-----------------|------------------------|-------|-------|-------|
| OFF | S5 | 1 | 1 | X |
| Steady Green | S0 | 0 | 1 | 0 |
| Blinking Green | S0(message waiting | 0 | B | 0 |
| Steady Yellow | S1, S3 | 1 | 0 | NO1 |
| Blinking Yellow | S1, S3(message waiting | 1 | B | NO1 |

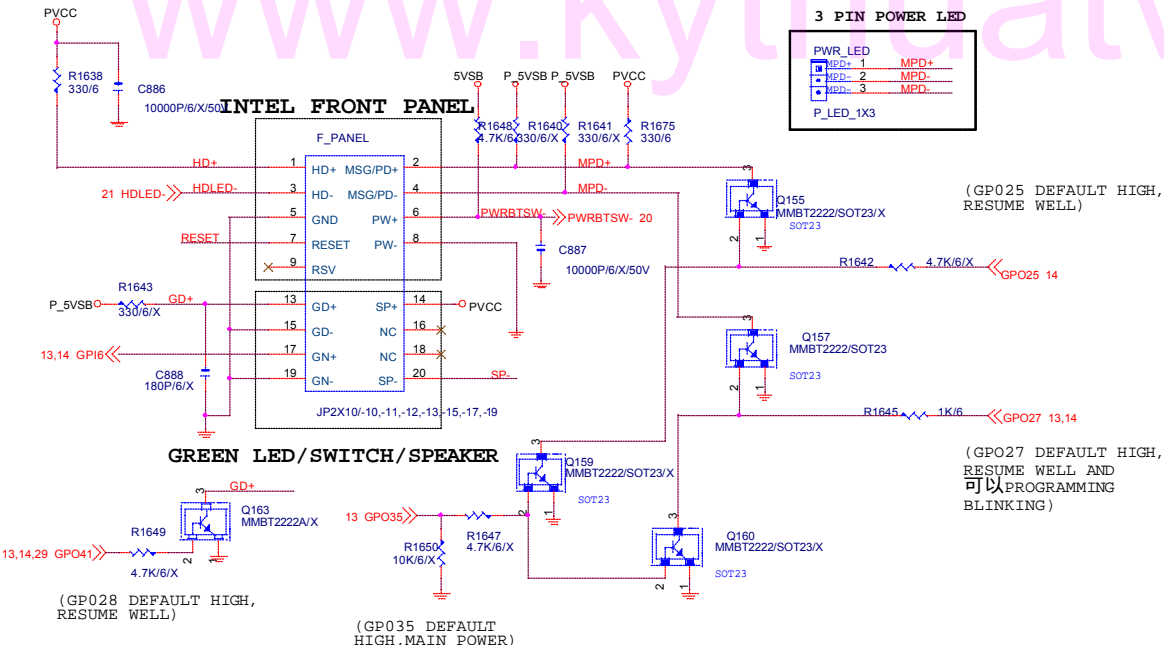

(GPO28 DEFAULT HIGH, RESUME WELL)

(GPO35 DEFAULT HIGH, MAIN POWER)

(GPO25 DEFAULT HIGH, RESUME WELL)

(GPO27 DEFAULT HIGH, RESUME WELL AND 可以PROGRAMMING BLINKING)

模組化線路

FOR ALC650 (需 E VERSION (含) 以上, 才 SUPPORT)

Support ALC650
If 14.318MHz
external CLK
is used

FOR ALC650
center out/low freq. effect out

FOR ALC650
surround out left/right
channel

FOR 650 DESIGN DEFAULT 由
CLOCK GEN

14.318MHz from clock
gen. CLK for 650
16 97CLK14

FOR 650 DESIGN DEFAULT
不上 CRYSTAL

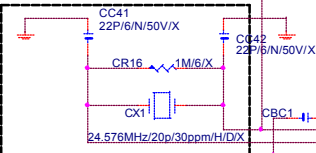

13 SDATA_OUT
13 BIT_CLK

13 SDATA_IN0
13 AC_SDIN2
13 SOUND_RST

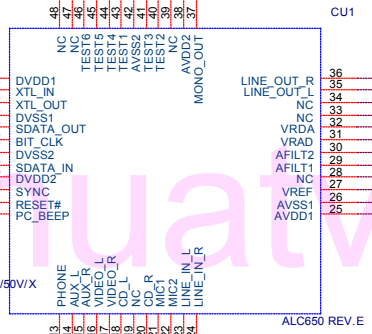

27 AUX_L
27 AUX_R

CC18 0.1u/6/Y/25V/X

CC25 2.2u/8/Y/16V
CC24 2.2u/8/Y/16V
CC19 1u/6/Y/10V
CC14 0.1u/6/Y/25V
CC20 0.1u/6/Y/25V
CC15 0.1u/6/Y/25V
CC64 1u/6/Y/10V/X
CC65 1u/6/Y/10V

AVDD

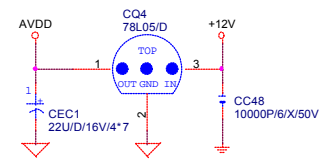

| | | | |
|----------------|-----------------------------|-----------|---------|
| GIGABYTE CORP. | | | |
| Title AC97 | | | |
| Size B | Document Number | GA-8IE533 | Rev 2.0 |
| Date: | Wednesday, October 30, 2002 | Sheet 26 | of 34 |

LINE-IN

模組化線路

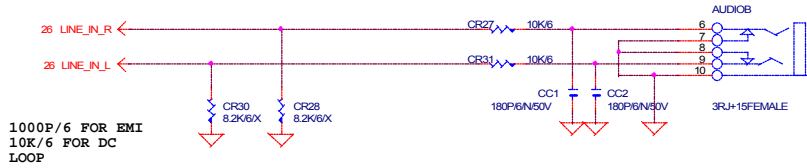

CDIN

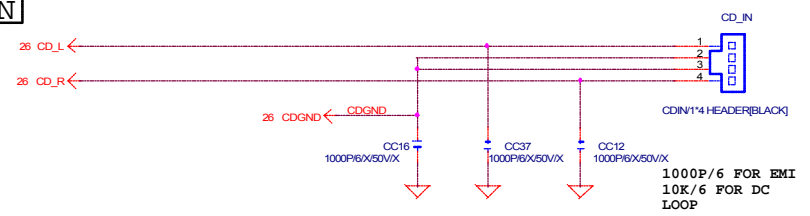

AUX_IN

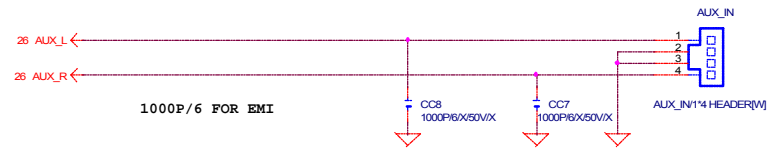

INTEL FRONT AUDIO

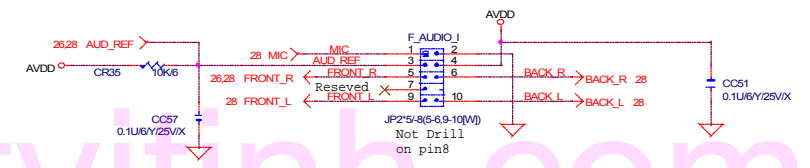

GAME_PORT

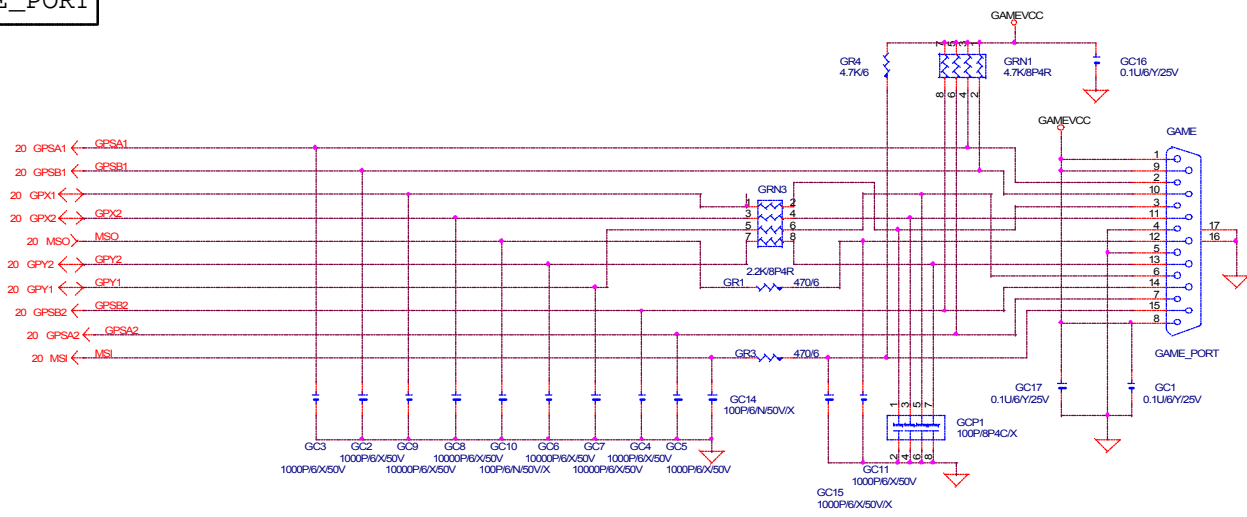

| | | | |
|-----------------------|-----------------------------|-------|----------|
| GIGABYTE CORP. | | | |
| Title | | | |
| PHONE JACK, GAME PORT | | | |
| Size | Document Number | Rev | |
| Custom | GA-8IE533 | 2.0 | |
| Date: | Wednesday, October 30, 2002 | Sheet | 27 of 34 |

www.kythuatvinh.com

模組化線路

LINE OUT

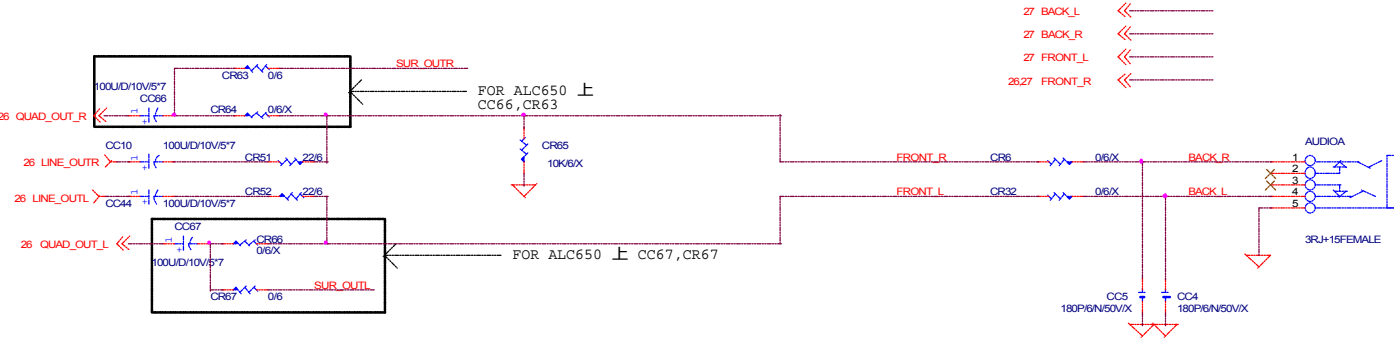

27 BACK_L <<<
 27 BACK_R <<<
 27 FRONT_L <<<
 26,27 FRONT_R <<<

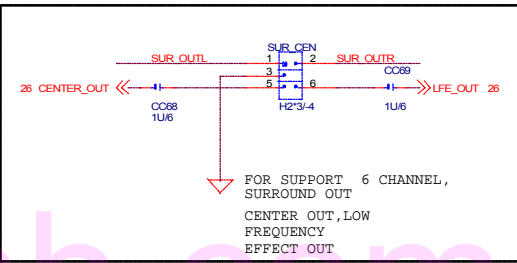

MIC

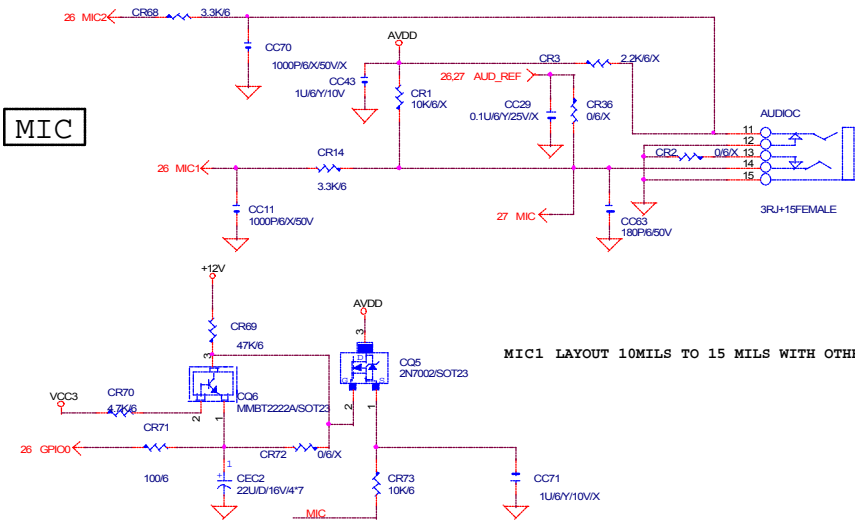

SPDIF

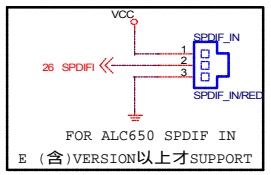
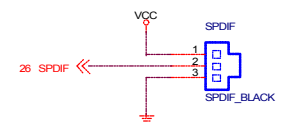

| | | | |
|------------------------------------|----------------------------------|----------------|--|
| GIGABYTE CORP. | | | |
| Title PHONE JACK, GAME PORT | | | |
| Size Custom | Document Number GA-8IE533 | Rev 2.0 | |
| Date: Wednesday, October 30, 2002 | Sheet 28 | of 34 | |

www.kythuatchinh.com

1.25V VTT_DDR LINEAR SOLUTION

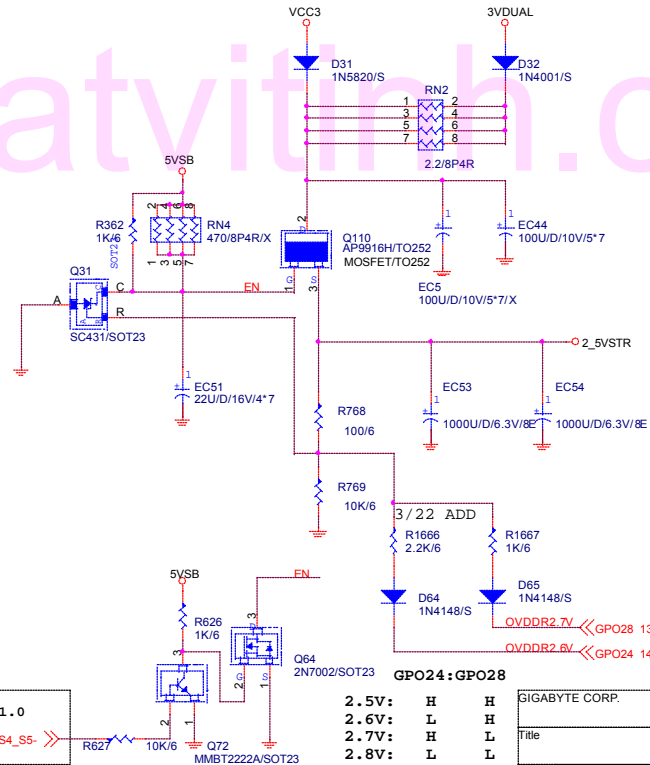
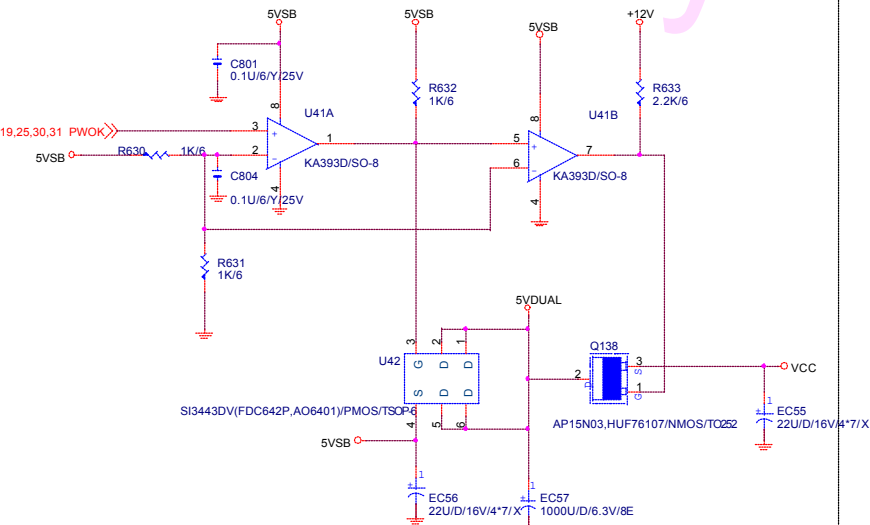
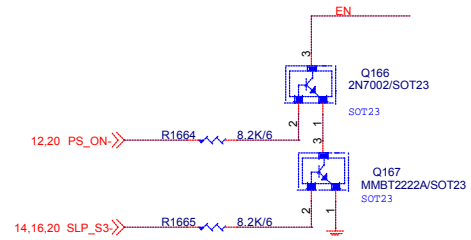
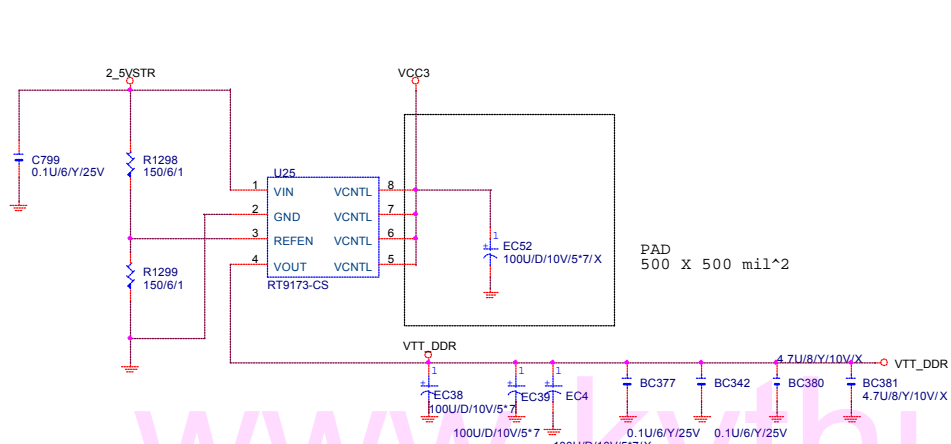

5VDUAL CIRCUIT

REV1.0
14,25 S4_S5-

GPO24:GPO28

| | | |
|-------|---|---|
| 2.5V: | H | H |
| 2.6V: | L | H |
| 2.7V: | H | L |
| 2.8V: | L | L |

| | | |
|-----------------------------------|-----------------|----------------|
| GIGABYTE CORP. | | |
| Title | | |
| DDR POWER | | |
| Size B | Document Number | Rev 2.0 |
| Date: Wednesday, October 30, 2002 | | Sheet 29 of 34 |

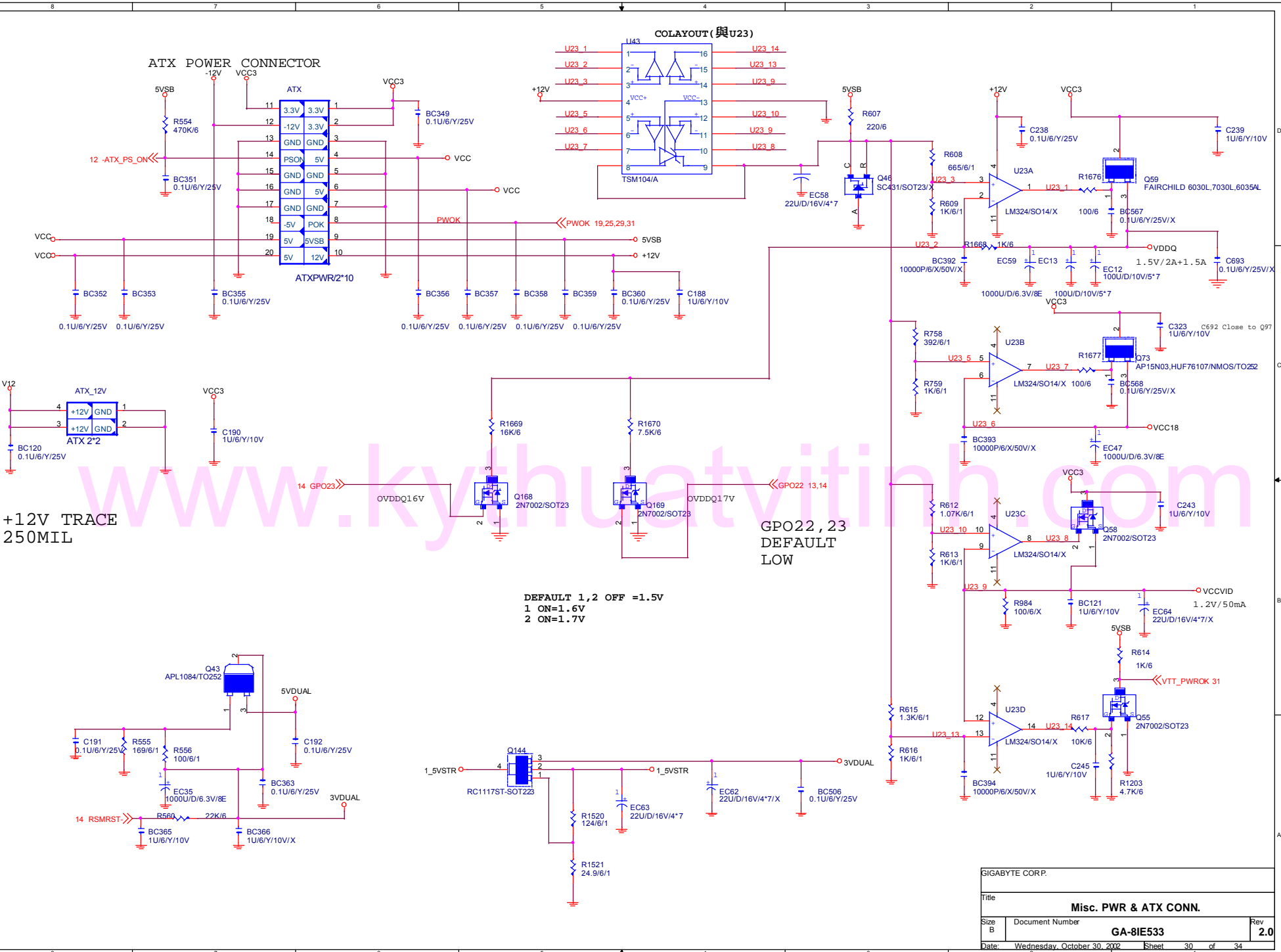

+12V TRACE
250MIL

DEFAULT 1,2 OFF = 1.5V
1 ON=1.6V
2 ON=1.7V

| | |
|----------------------------------|------------------|
| GIGABYTE CORP. | |
| Title | |
| Misc. PWR & ATX CONN. | |
| Size B | Document Number |
| | GA-8IE533 |
| Date: | Rev 2.0 |
| Wednesday, October 30, 2002 | Sheet 30 of 34 |

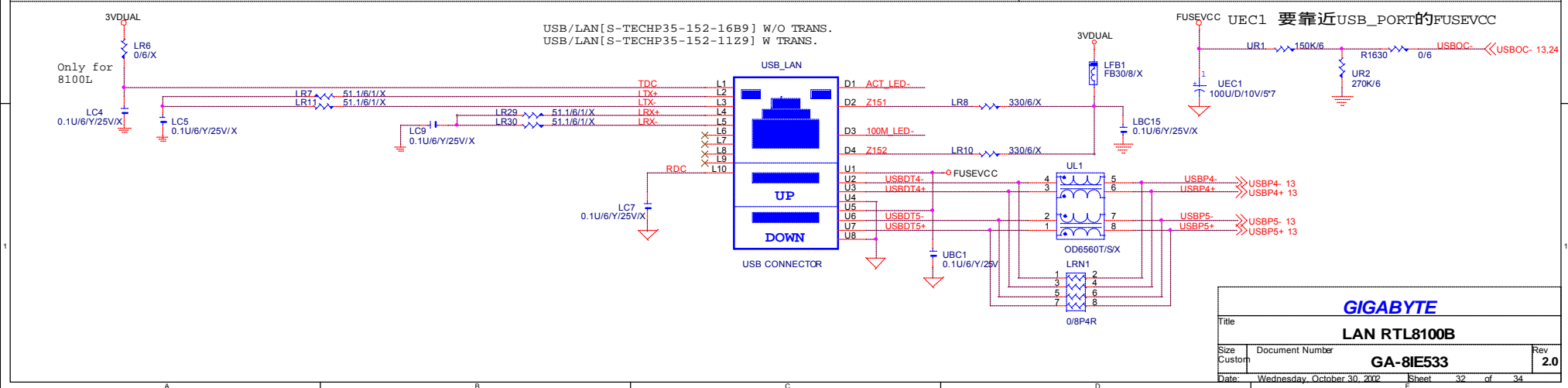
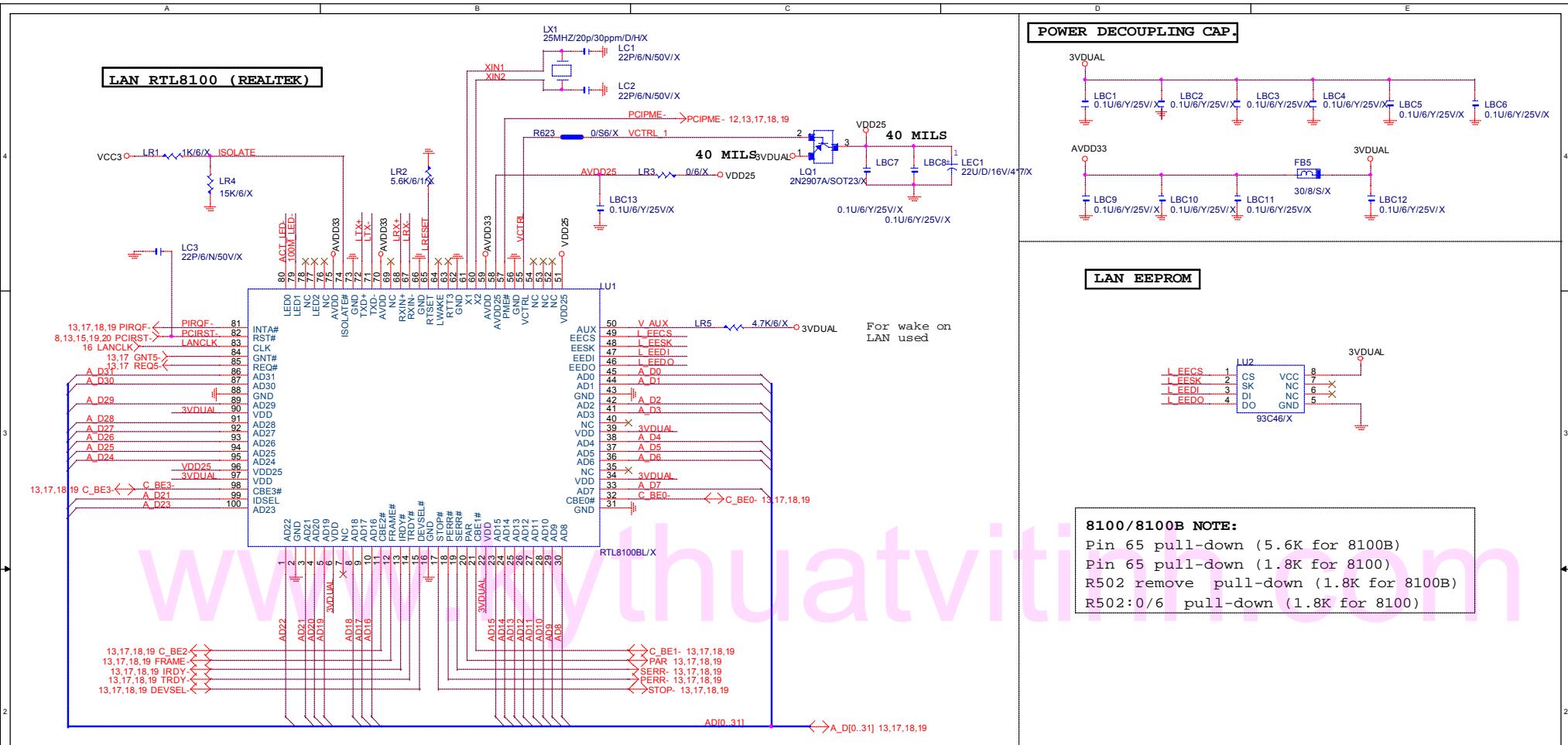

GIGABYTE GA-8IE533 GPIO LIST

Revision 2.0

SHEET

TITLE

| GPI | | |
|---------------|----|----------------------------------|
| GPI0/REQA- | NA | PULL 8.2K TO VCC3 |
| GPI1/REQ5- | | PULL 2.7K TO VCC |
| GPI2/PIRQE- | ID | PULL 8.2K TO VCC3 (default) |
| GPI3/PIRQF- | | PULL 8.2K TO VCC3 |
| GPI4/PIRQG- | | PULL 8.2K TO VCC3 |
| GPI5/PIRQH- | ID | PULL 8.2K TO VCC3 (default) |
| GPI6 | | PULL 8.2K TO VCC3 (GREEN BUTTON) |
| GPI7 | | PULL DOWN 10K TO GND |
| GPI8 | ID | PULL 8.2K TO VCC3 (default) |
| GPI9 | NA | NOT IMPLEMENTED |
| GPI10 | NA | NOT IMPLEMENTED |
| GPI11 | | PULL 4.7K TO 3VDUAL (SMBALERT) |
| GPI12/LPCPME- | | PULL 8.2K TO 3VDUAL (PME-) |
| GPI13 | | NC |
| GPI14 | NA | NOT IMPLEMENTED |
| GPI15 | NA | NOT IMPLEMENTED |
| | | |
| | | |
| | | |
| | | |
| | | |

SHEET

TITLE

| GPO | | |
|------------|----|---|
| GPO16 | NA | PULL 8.2K TO VCC3 (CAN'T PULL DOWN) 因為會 decode bios address 不正確:FF |
| GPO17 | | PULL 8.2K TO VCC3 (GNT5-) |
| GPO18 | NA | PULL 8.2K TO VCC3 此OUTPUT 會 TOGGLE. (在開機時) BIOS POST OK |
| GPO19 | | PULL 8.2K TO VCC3 |
| GPO20 | | PULL 8.2K TO VCC3 |
| GPO21 | | PULL 8.2K TO VCC3 (TOP BLOCK) |
| GPO22 | | PULL 8.2K TO VCC3 |
| GPO23 | | PULL 8.2K TO VCC3 |
| GPO24 | | PULL 4.7K TO 3VDUAL |
| GPO25 | | PULL 4.7K TO 3VDUAL (POWER LED) |
| GPO26 | | NOT IMPLEMENTED |
| GPO27 | | PULL 8.2K TO 3VDUAL (POWER LED) |
| GPO28 | | PULL 8.2K TO 3VDUAL |
| GPO32 | | PULL 8.2K TO 3VDUAL (BIOS WRITE PROTECT) |
| GPO35 | | PULL DOWN 10K TO GND (POWER LED) |
| | | |

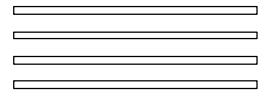
| | | |
|---|-----------------------------|---|
|  | | COMPONENT SIDE (0.5 oz. Copper) VCC SIDE (1 oz. Copper) GND SIDE (1 oz. Copper) SOLDER SIDE (0.5 oz. Copper) |
| GIGABYTE | | |
| Title | | |
| GPIO LIST | | |
| Size | Document Number | Rev |
| Custom | GA-8IE533 | 2.0 |
| Date: | Wednesday, October 30, 2002 | Sheet 33 of 34 |

