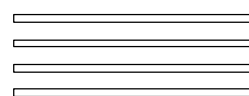

8ST800 Schematics

Revision 1.0

SHEET	TITLE
1	COVER SHEET
2	BOM & PCB MODIFY HISTORY
3	BLOCK DIAGRAM
4,5,6	INTEL CPU_WMT_478
7-10	SIS645 (NORTH BRIDGE) HOST; DDR; AGP,HYPER ZIP
11-14	SIS961 (SOUTH BIRDGE)
15	CLOCK GENERATOR (ICS952001)
16,17	DDR SDRAM DIMMS 1,2,3
18	AGP SLOT
19,20	PCI SLOT 1,2,3,4,5,6
21	IDE,FRONT USB,PCIRST#
22	LPCIO_IT8705
23	BIOS
24	COM,PRT,FDD,KB/MS,IR
25	AUDIO AC 97
26	AUDIO JACK,GAME PORT
27	FAN, IR PORT
28	PANEL,STR LED,FANS ,CPU GN
29	VCORE PHASE PWM HIP 6302 + 6602
30	VDDQ, VCC18, VCCVID
31	ATX CONN, GPIO LIST
32	RTL8100BL
33	DDR POWER,3VDUAL

PCB Size: 294*210 mm

	
GIGABYTE	
COVER SHEET	
Size Custom	Document Number
GA-8ST800	
Date: Wednesday, December 25, 2002	Rev 1.0
Sheet 1 of 33	

8ST800 BLOCK DIAGRAM

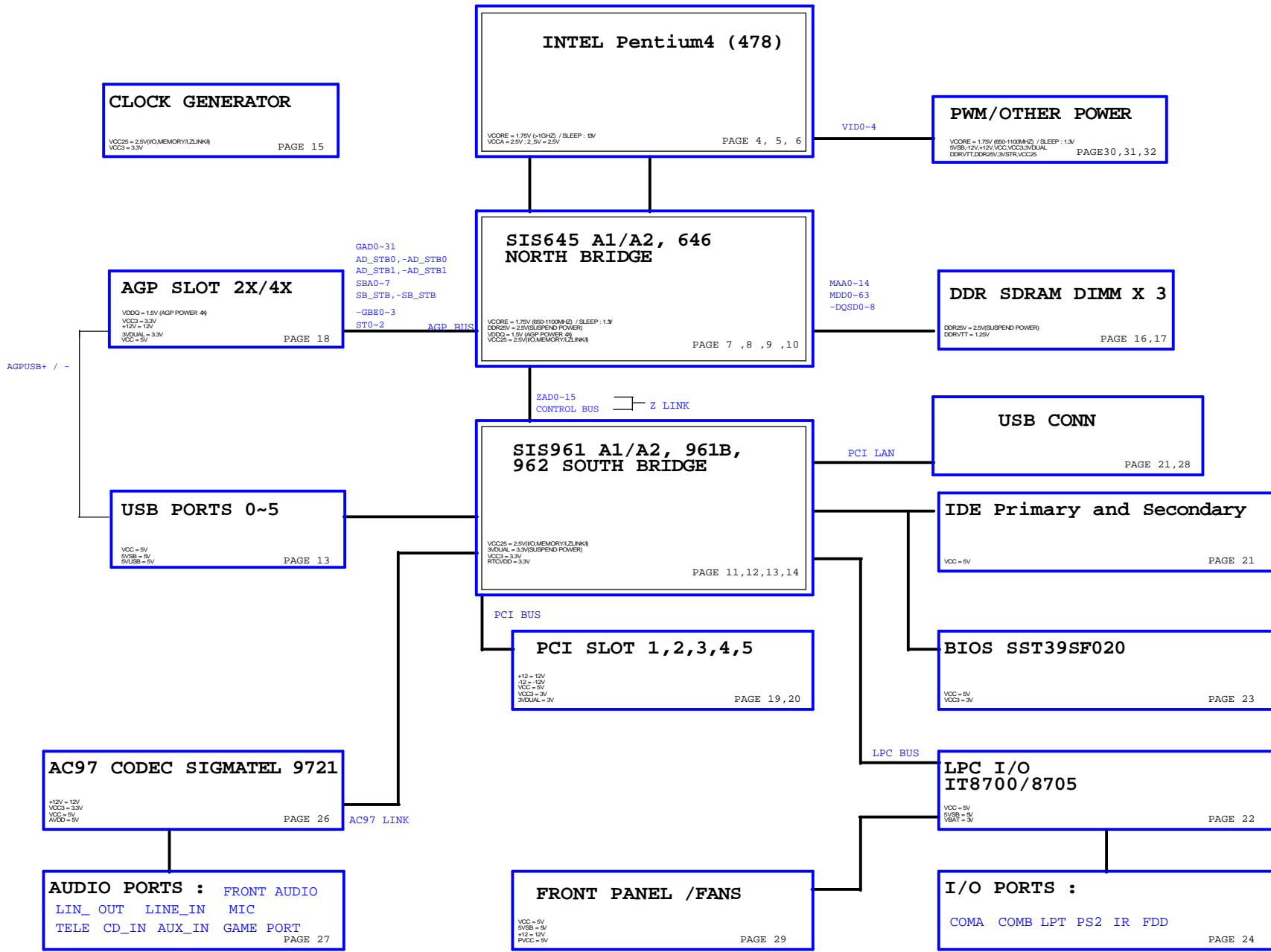

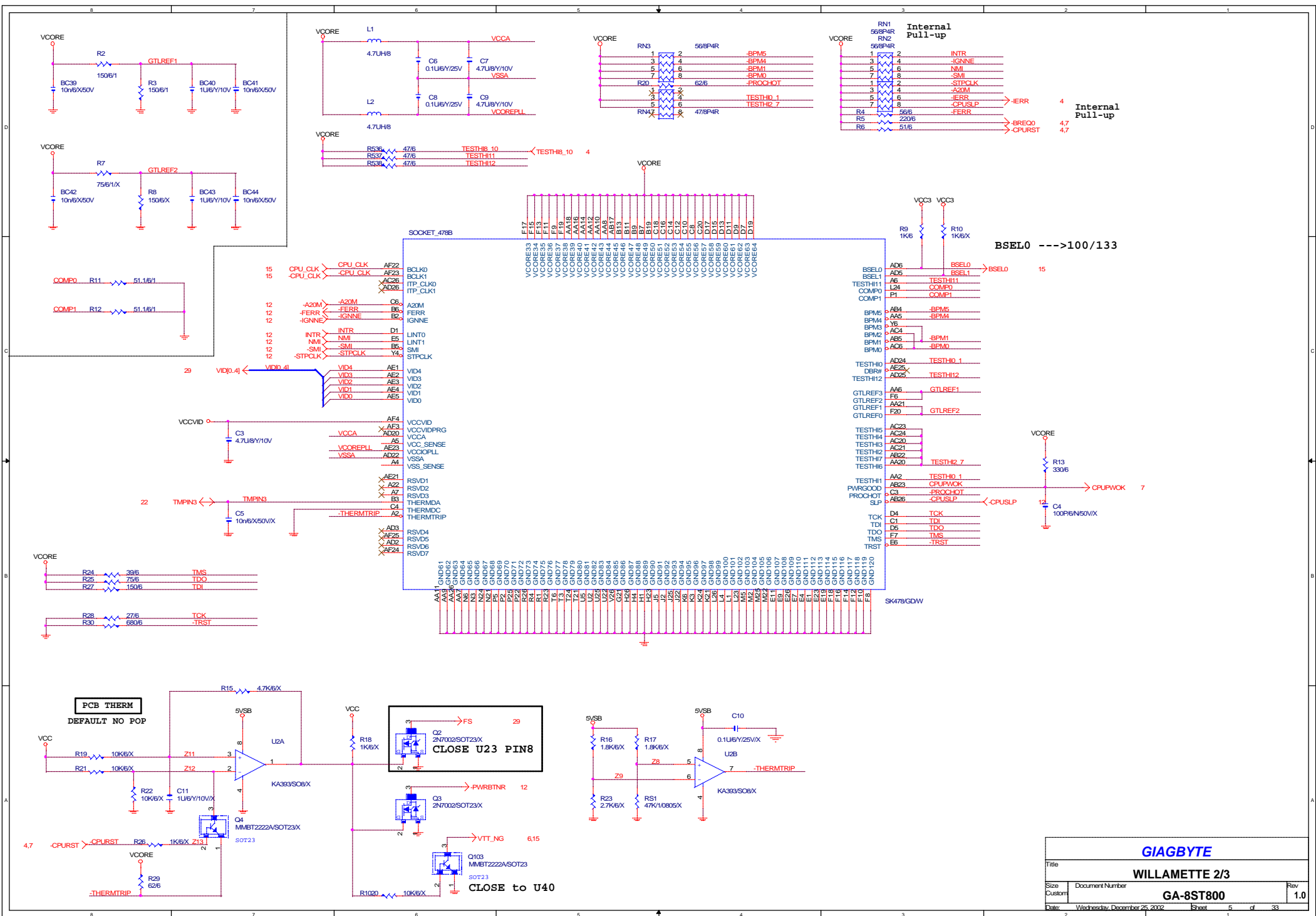

GIAGBYTE		
WILLAMETTE 2/3		
Title	Document Number	Rev
	GA-8ST800	1.0
Date:	Wednesday, December 25, 2002	Sheet 5 of 33

SIS 645 A1/A2 , 646
共用

AGP

645-1

HOST

- DB[0..3] <-> -DB[0..3] 6
- HD[0..63] <-> HD[0..63] 6
- HA[3..31] <-> HA[3..31] 4
- GD[0..31] <-> GD[0..31] 18
- SBA[0..7] <-> SBA[0..7] 18
- ST[0..2] <-> ST[0..2] 18

- 15 HCLK <-> HCLK AJ26
- 15 -HCLK <-> -HCLK AH26
- 4 -HLOCK <-> -HLOCK U24
- 4 -DEFER <-> -DEFER U26
- 4 -HTRDY <-> -HTRDY V26
- 4,5 -CPURST <-> -CPURST C20
- 5 -CPUPWOK <-> -CPUPWOK D19
- 4 -BPRI <-> -BPRI T27
- 4,5 -BREQ0 <-> -BREQ0 U25
- 4 -RS2 <-> -RS2 T24
- 4 -RS1 <-> -RS1 T26
- 4 -RS0 <-> -RS0 U29
- 4 -ADS <-> -ADS V28
- 4 -HITM <-> -HITM T28
- 4 -HIT <-> -HIT U28
- 4 -DRDY <-> -DRDY W26
- 4 -DBSY <-> -DBSY V24
- 4 -BNR <-> -BNR V27
- 4 -HREQ4 <-> -HREQ4 W28
- 4 -HREQ3 <-> -HREQ3 W29
- 4 -HREQ2 <-> -HREQ2 W24
- 4 -HREQ1 <-> -HREQ1 W25
- 4 -HREQ0 <-> -HREQ0 Y27
- 4 -HA_STB1 <-> -HA_STB1 AD24
- 4 -HA_STB0 <-> -HA_STB0 AA24

- HA31 AF26
- HA30 AE25
- HA29 AH28
- HA28 AD26
- HA27 AG29
- HA26 AE26
- HA25 AF28
- HA24 AC24
- HA23 AG28
- HA22 AE29
- HA21 AD28
- HA20 AC25
- HA19 AD27
- HA18 AE26
- HA17 AF27
- HA16 AB24
- HA15 AB26
- HA14 AC28
- HA13 AC26
- HA12 AC29
- HA11 AA26
- HA10 AB28
- HA9 AB27
- HA8 AA25
- HA7 AA29
- HA6 AA28
- HA5 Y26
- HA4 Y24
- HA3 Y28

- HD#63
- HD#62
- HD#61
- HD#60
- HD#59
- HD#58
- HD#57
- HD#56
- HD#55
- HD#54
- HD#53
- HD#52
- HD#51
- HD#50
- HD#49
- HD#48
- HD#47
- HD#46
- HD#45
- HD#44
- HD#43
- HD#42
- HD#41
- HD#40
- HD#39
- HD#38
- HD#37
- HD#36
- HD#35
- HD#34
- HD#33
- HD#32
- HD#31
- HD#30
- HD#29
- HD#28
- HD#27
- HD#26
- HD#25
- HD#24
- HD#23
- HD#22
- HD#21
- HD#20
- HD#19
- HD#18
- HD#17
- HD#16
- HD#15
- HD#14
- HD#13
- HD#12
- HD#11
- HD#10
- HD#9
- HD#8
- HD#7
- HD#6
- HD#5
- HD#4
- HD#3
- HD#2
- HD#1
- HD#0
- DB#3
- DB#2
- DB#1
- DB#0

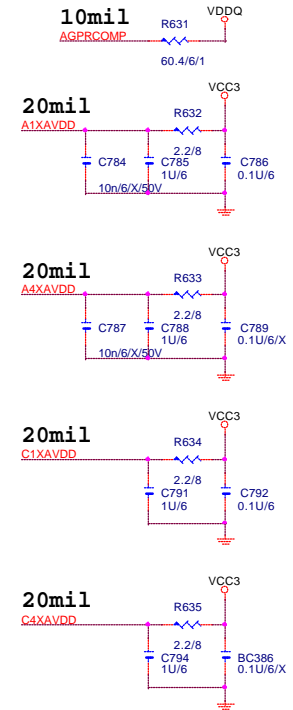
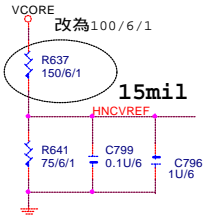
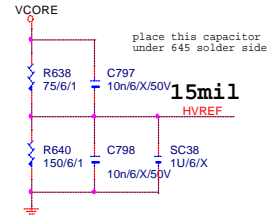
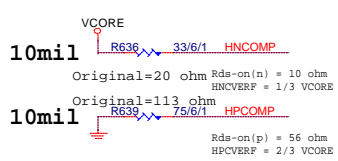

N.B HEATSINK

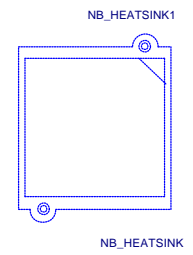

GIGABYTE		
SIS645(HOST/AGP)		
Title	Document Number	Rev
	GA-8ST800	1.0
Date:	Wednesday, December 25, 2002	Sheet 7 of 33

DQM[0..7] → DQM[0..7] 16,17
 MA[A0..14] → MA[A0..14] 16,17
 DQSD[0..7] → DQSD[0..7] 16,17
 CKE[0..5] → CKE[0..5] 16,17

SIS 645 A1/A2, 646
共用

U38B

645-2

MD0	AJ23	MD0/SMD63
MD1	AG22	MD1/SMD30
MD2	AH21	MD2/SMD29
MD3	AJ21	MD3/SMD59
MD4	AD23	MD4/SMD31
MD5	AE23	MD5/SMD62
MD6	AF22	MD6/SMD57
MD7	AF21	MD7/SMD28
DQMD0	AD22	DQM0/SMD61
DQSD0	AH22	DQS0/CSB#0
MD8	AD21	MD8/SMD27
MD9	AG20	MD9/SMD58
MD10	AE19	MD10/SMD55
MD11	AF19	MD11/SMD23
MD12	AE21	MD12/SMD26
MD13	AD20	MD13/SMD56
MD14	AD19	MD14/SMD24
MD15	AH19	MD15/SMD25
DQMD1	AD20	DQM1/SMD25
DQSD1	AH20	DQS1/CSB#1
MD16	AF18	MD16/SMD22
MD17	AG18	MD17/SMD53
MD18	AH17	MD18/SMD20
MD19	AD16	MD19/SMD19
MD20	AD18	MD20/SMD54
MD21	AD17	MD21/SMD21
MD22	AF17	MD22/SMD51
MD23	AJ17	MD23/SMD50
DQMD2	AE17	DQM2/SMD52
DQSD2	AH18	DQS2/CSB#2
MD24	AD14	MD24/SMD18
MD25	AG14	MD25/SMD27
MD26	AJ13	MD26/SMD07
MD27	AE13	MD27/SMD06
MD28	AJ15	MD28/SMD49
MD29	AD14	MD29/SMD03
MD30	AD13	MD30/SMD16
MD31	AF13	MD31/SMD47
DQMD3	AH13	DQM3/SMD16
DQSD3	AH14	DQS3/CSB#3
MD32	AD10	MD32/SMD05
MD33	AH10	MD33/SMD47
MD34	AE9	MD34/SMD45
MD35	AD8	MD35/SMD41
MD36	AG10	MD36/SMD01
MD37	AF10	MD37/SMD00
MD38	AH9	MD38/SMD46
MD39	AF9	MD39/SMD15
DQMD4	AD9	DQM4/SMD15
DQSD4	AJ9	DQS4/CSB#4
MD40	AH5	MD40/SMD13
MD41	AG4	MD41/SMD43
MD42	AE5	MD42/SMD42
MD43	AH3	MD43/SMD10
MD44	AG6	MD44/SMD44
MD45	AF6	MD45/SMD12
MD46	AF5	MD46/SMD9
MD47	AF4	MD47/SMD11
DQMD5	AH4	DQM5/SMD11
DQSD5	AJ3	DQS5/CSB#5
MD48	AE4	MD48/SMD40
MD49	AD6	MD49/SMD8
MD50	AE2	MD50/SMD37
MD51	AG5	MD51/SMD36
MD52	AG2	MD52/SMD39
MD53	AG1	MD53/SMD7
MD54	AF3	MD54/SMD6
MD55	AC6	MD55/SMD5
DQMD6	AD4	DQM6/SMD38
DQSD6	AF2	DQS6/CSB#6
MD56	AB6	MD56/SMD35
MD57	AD3	MD57/SMD34
MD58	AA6	MD58/SMD1
MD59	AB3	MD59/SMD0
MD60	AC4	MD60/SMD4
MD61	AE1	MD61/SMD3
MD62	AD2	MD62/SMD33
MD63	AC1	MD63/SMD32
DQMD7	AB4	DQM7/SMD2
DQSD7	AC2	DQS7/CSB#7

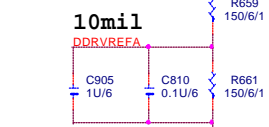
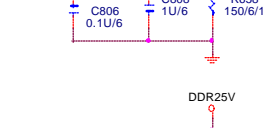
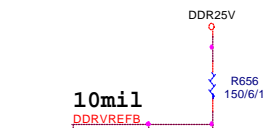
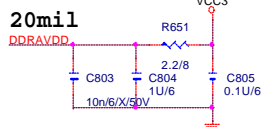
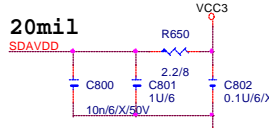
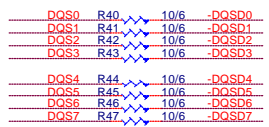
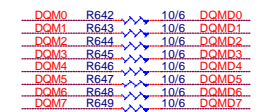
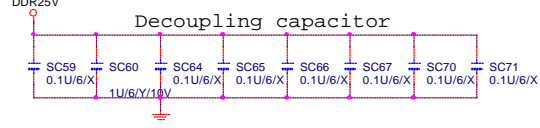
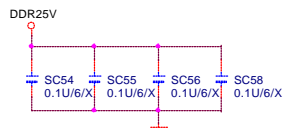
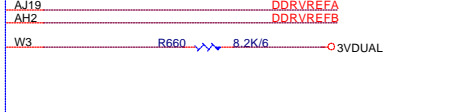
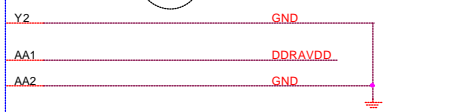
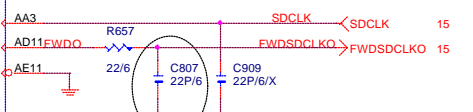
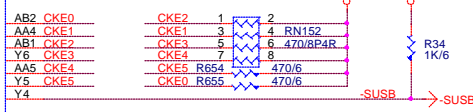
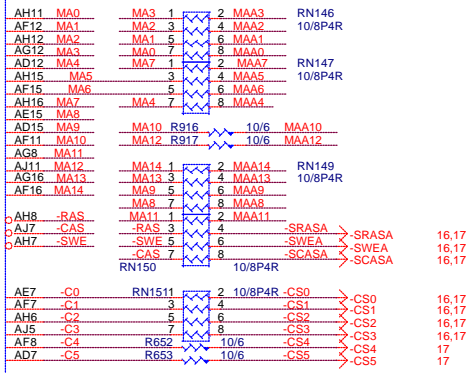

DDR MD DAMPING

Near DIMM 1

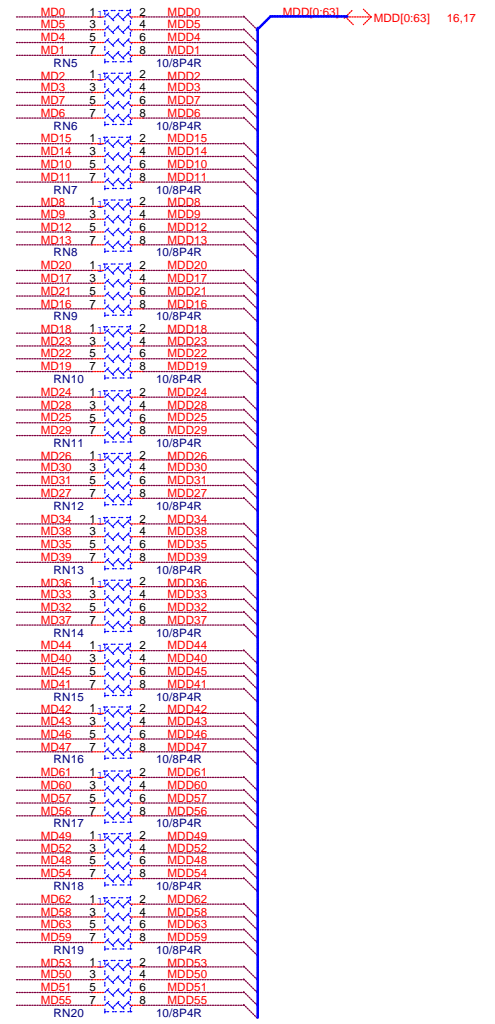

GIGABYTE		
Title: SIS645(DDR)		
Size: Custom	Document Number: GA-8ST800	Rev: 1.0
Date: Wednesday, December 25, 2002	Sheet: 8	of 33

ZAD[0..15] → ZAD[0..15] 11

SIS 645 A1/A2 , 646 共用

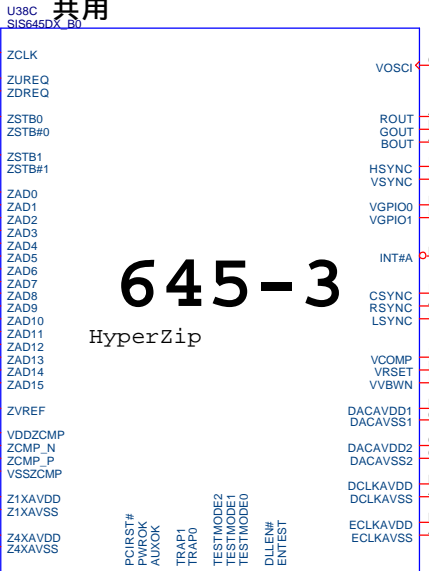

645-3

HyperZip

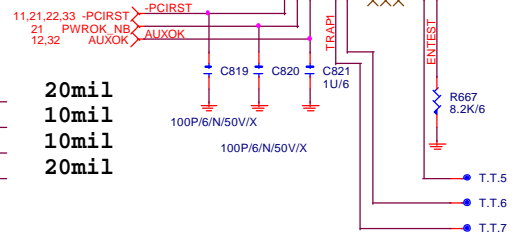
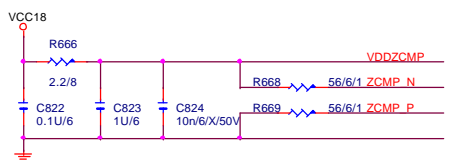
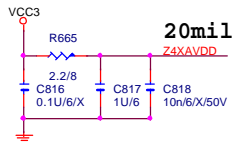
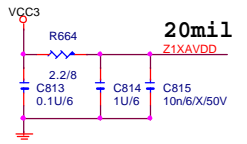
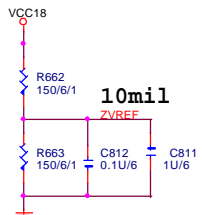

GIGABYTE		
Title SIS645(HYPER ZIP)		
Size	Document Number GA-8ST800	Rev 1.0
Date:	Wednesday, December 25, 2002	Sheet 9 of 33

645-4

Power

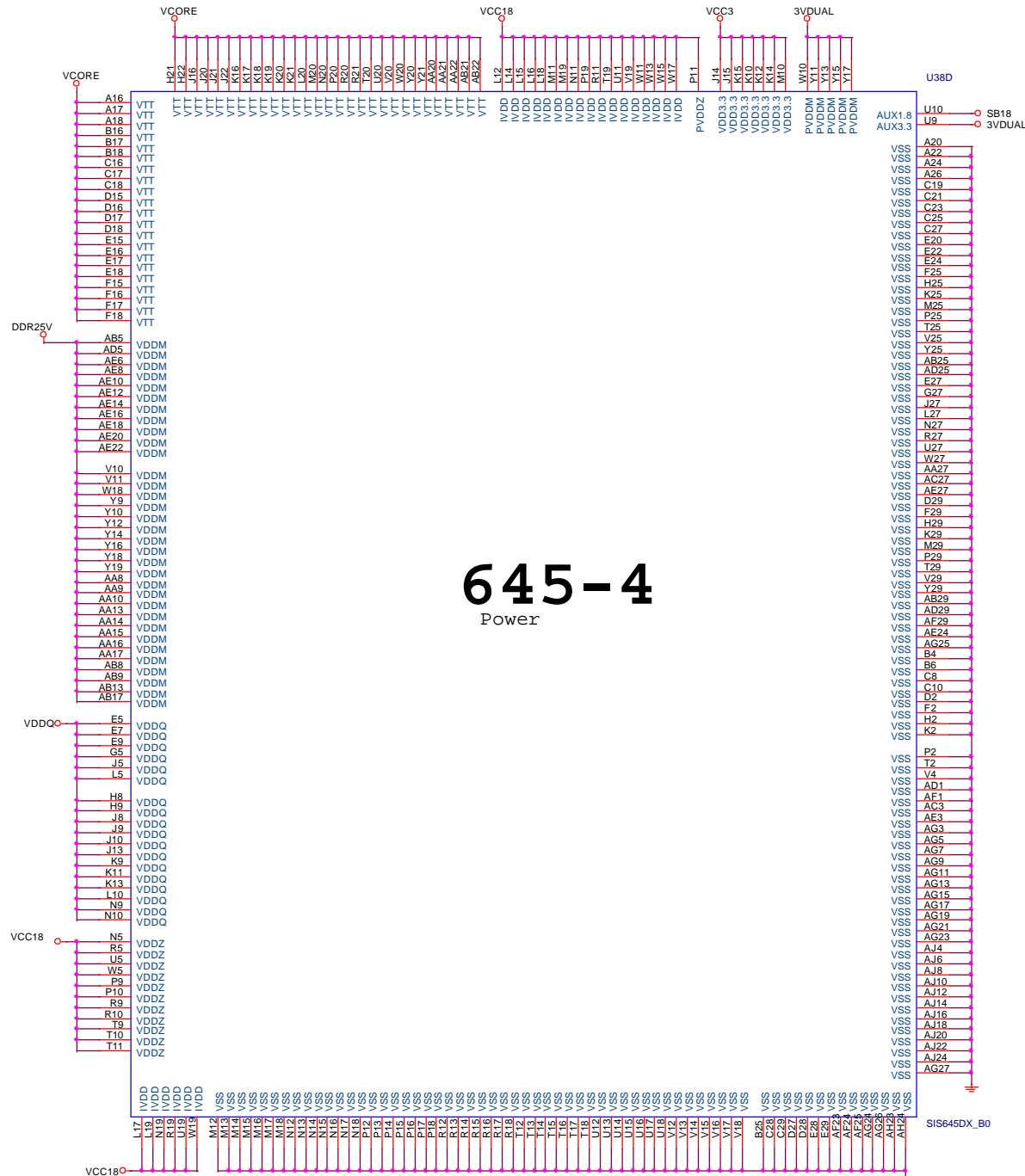

SIS 645 A1/A2 , 646
共用

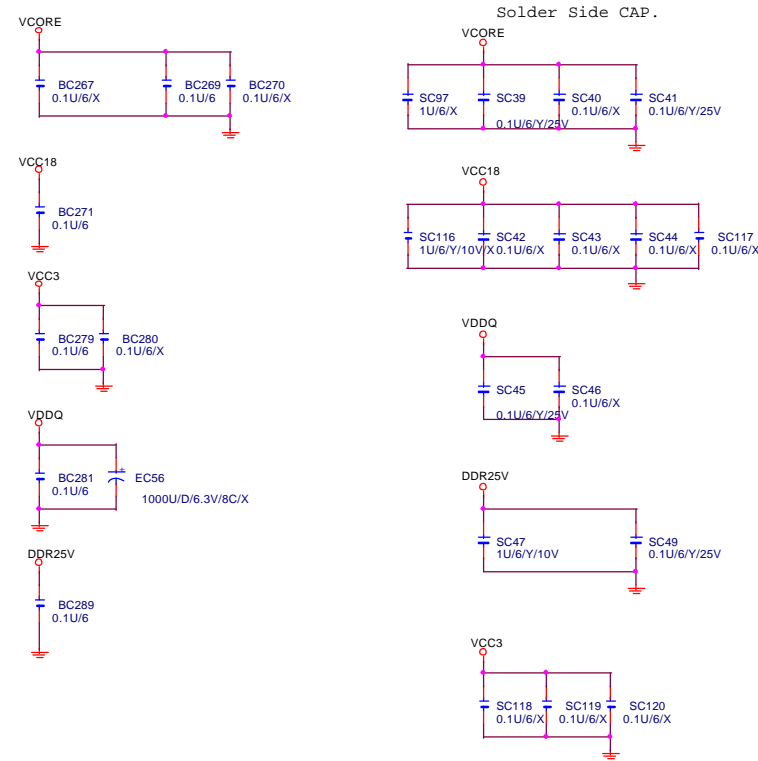

GIGABYTE		
Title SIS645(PWR)		
Size Custom	Document Number GA-8ST800	Rev 1.0
Date:	Wednesday, December 25, 2002	Sheet 10 of 33

SIS 961 A1/A2 , 961B, 962
共用

961A-3

USB

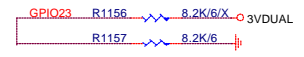
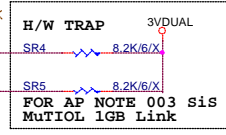
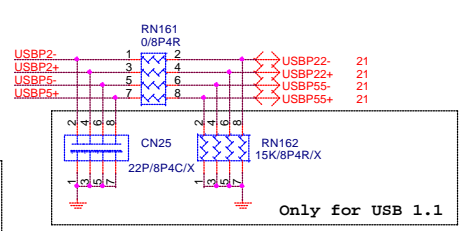
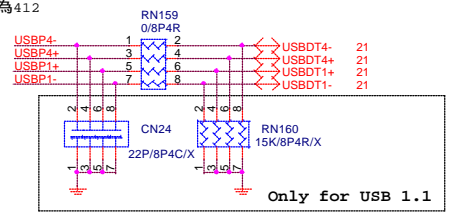
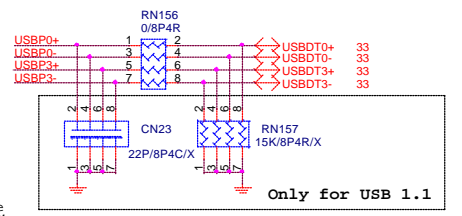
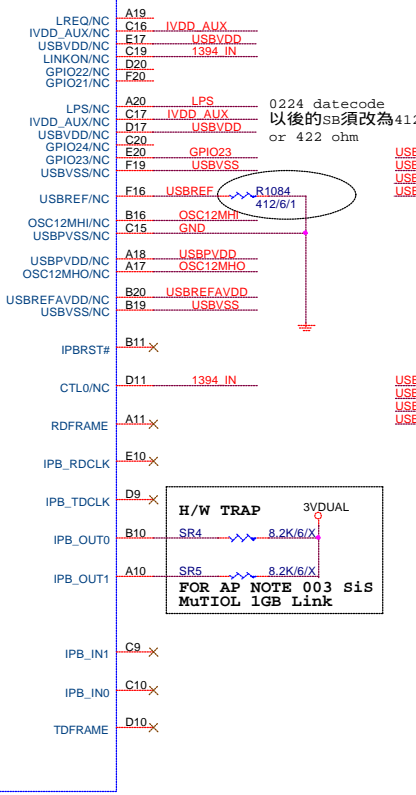
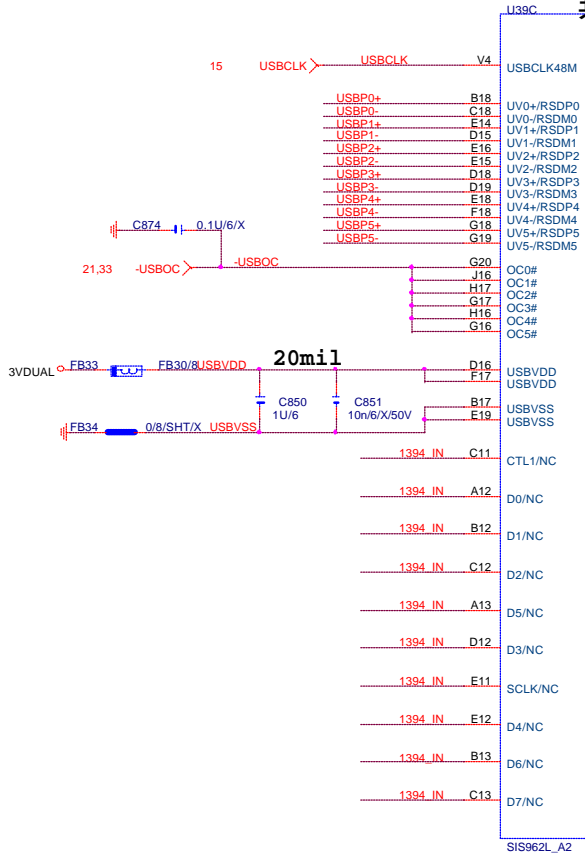

All of 1394 pin:
Output pin(LPS, LREQ) can be open.
All input pin connect together
and pull-down to gnd.

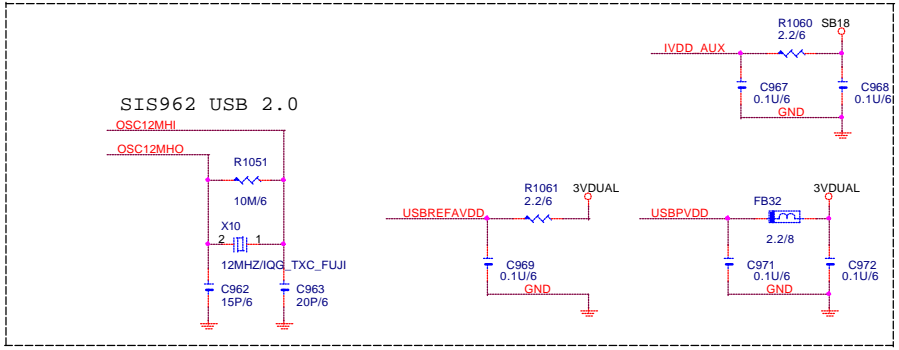
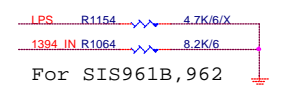

GIGABYTE		
SIS961A(USB)		
Title	Document Number	Rev
	GA-8ST800	1.0
Date:	Wednesday, December 25, 2002	Sheet 13 of 33

SIS 961 A1/A2 , 961B, 962

共用
VCC18

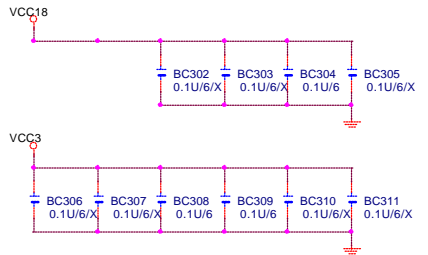
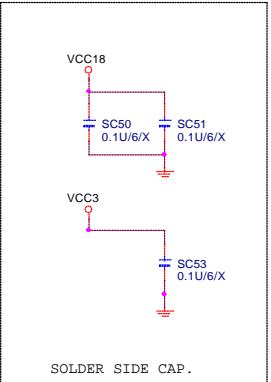
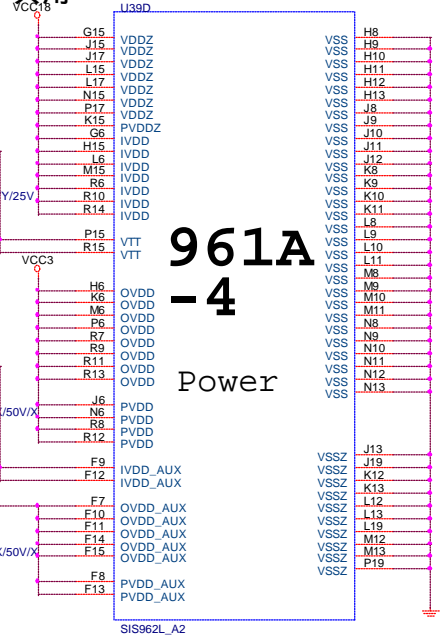

GIGABYTE		
Title SIS961A(PWR)		
Size Custom	Document Number GA-8ST800	Rev 1.0
Date:	Wednesday, December 25, 2002	Sheet 14 of 33

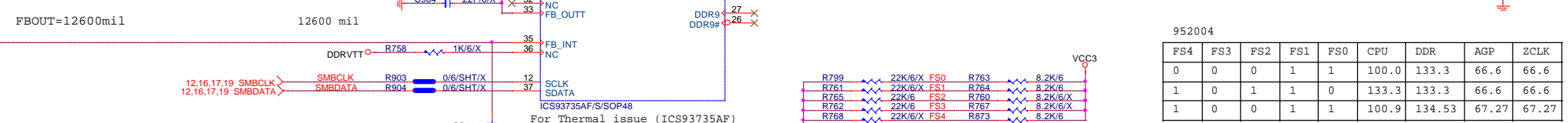
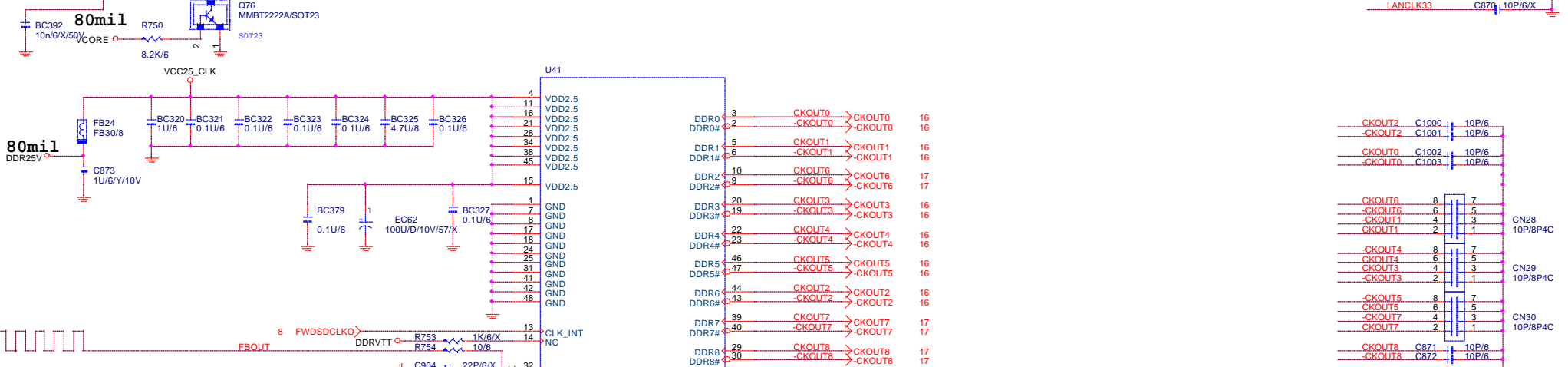
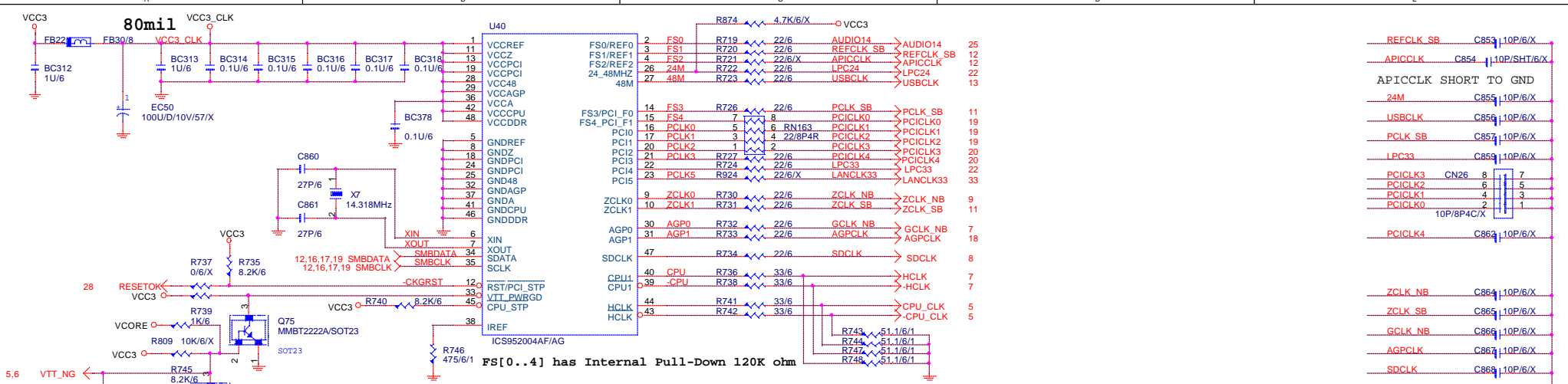

ICS 952004 / 952005 CLOCK BOM OPTION TABLE

Option	R763	R799	R764	R761	R760	R765	R767	R762	R873	R768	R801	R1095	R808	R795	R1094
952004	R763	R799	R764	R761	R760	R765	R767	R762	R873	R768	R801	R1095	R808	R795	R1094
100.9->133.3	10K	N/A	10K	N/A	N/A	22K	N/A	22K	10K	N/A	2.2K	N/A	N/A	1K	N/A
100.0->133.3	10K	N/A	10K	N/A	N/A	22K	N/A	22K	N/A	22K	2.2K	N/A	2.2K	1K	N/A

Option	R763	R799	R764	R761	R760	R765	R767	R762	R873	R768	R801	R1095	R808	R795	R1094
952005	R763	R799	R764	R761	R760	R765	R767	R762	R873	R768	R801	R1095	R808	R795	R1094
100.9->133.9	10K	N/A	10K	N/A	N/A	22K	N/A	22K	10K	N/A	2.2K	2.2K	N/A	N/A	1K
100.0->133.3	10K	N/A	10K	N/A	N/A	22K	N/A	22K	N/A	22K	2.2K	N/A	2.2K	N/A	N/A

952004

FS4	FS3	FS2	FS1	FS0	CPU	DDR	AGP	ZCLK
0	0	0	1	1	100.0	133.3	66.6	66.6
1	0	1	1	0	133.3	133.3	66.6	66.6
1	0	0	1	1	100.9	134.53	67.27	67.27

952005

FS4	FS3	FS2	FS1	FS0	CPU	DDR	AGP	ZCLK
0	0	0	1	1	100.0	133.3	66.6	66.6
0	1	0	1	1	133.3	133.3	66.6	66.6
1	0	0	1	1	100.9	134.53	67.27	67.27
0	1	1	1	1	133.9	133.9	66.9	66.9

GIGABYTE

CLOCK GEN + SDR BUFFER

Title: **CLOCK GEN + SDR BUFFER**

Size: **GA-8ST800**

Document Number: **GA-8ST800**

Date: Wednesday, December 25, 2002

Sheet: 15 of 33

Rev: **1.0**

DDR SDRAM 1,2

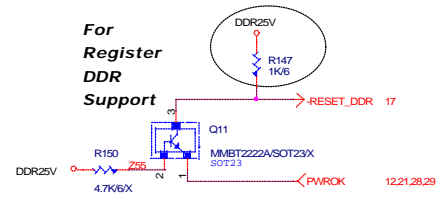
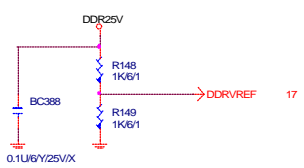
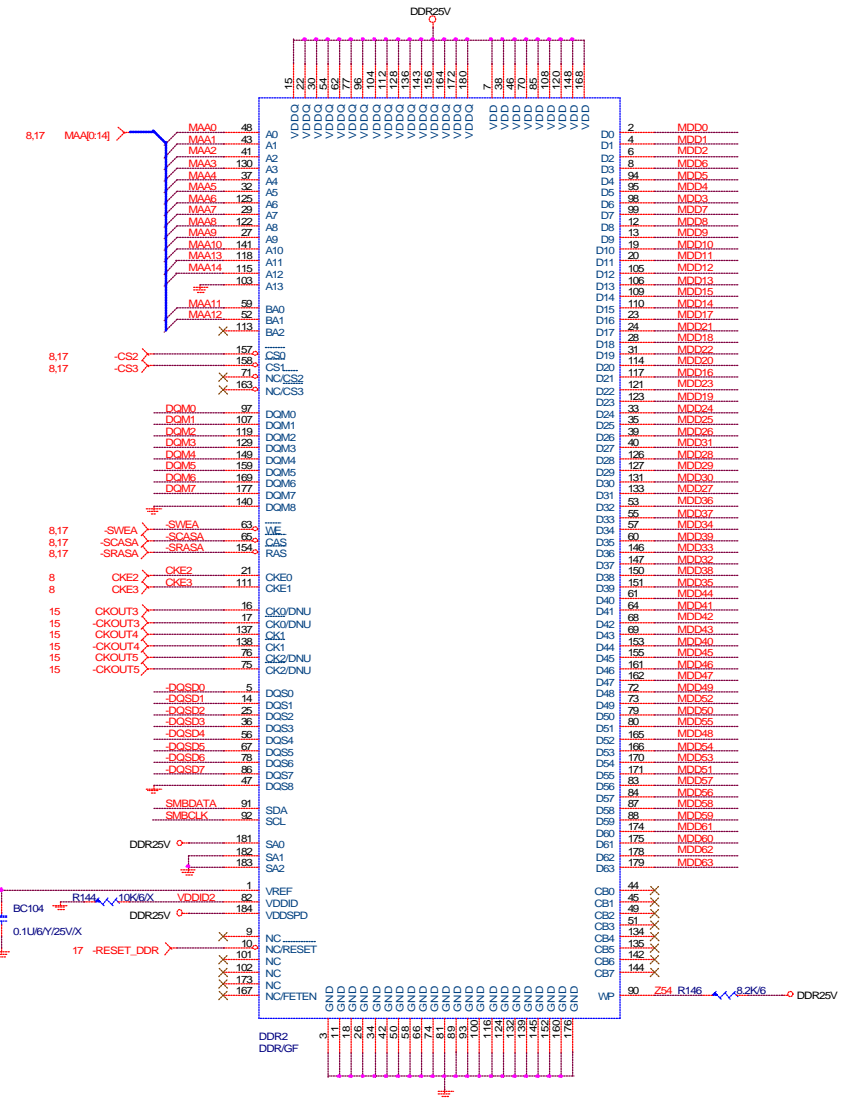
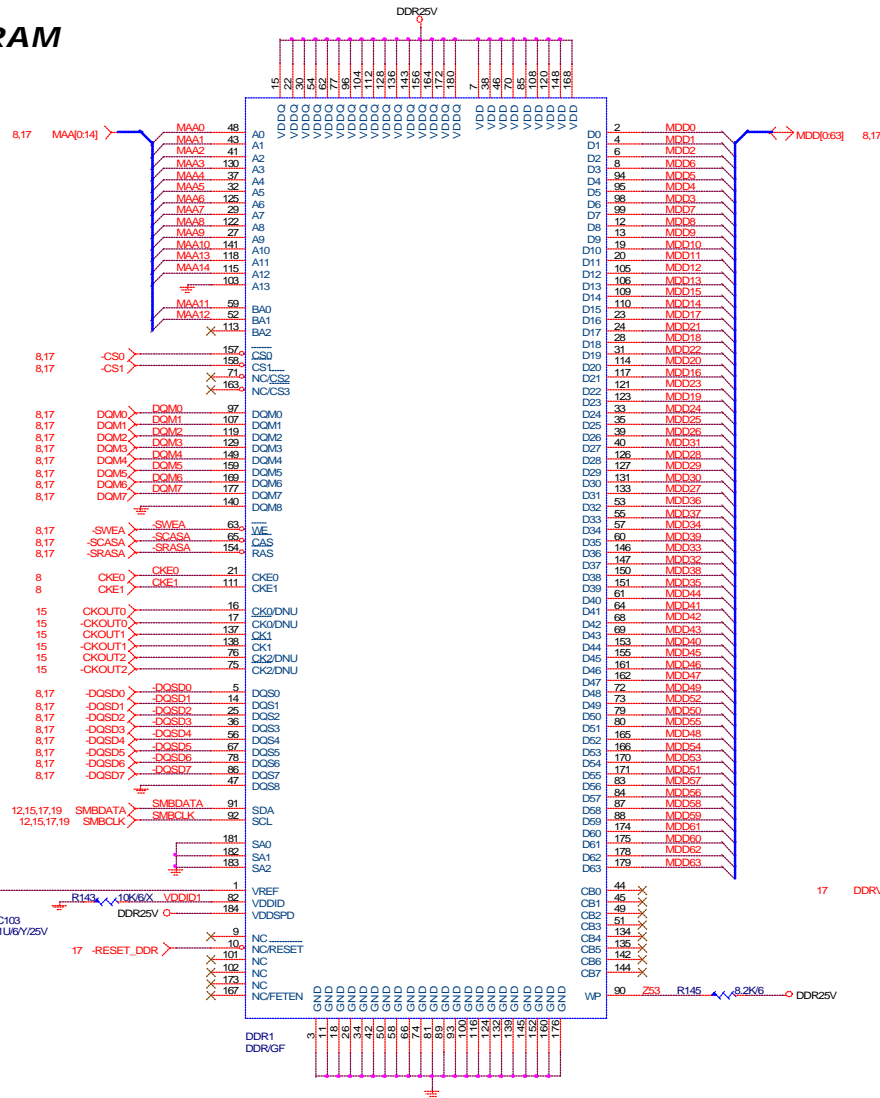

GIGABYTE		
DDR UNBUFFERED 1,2		
Title	Document Number	Rev
	GA-8ST800	1.0
Date:	Wednesday, December 25, 2002	Sheet 16 of 33

PCI SLOT 1,2,3

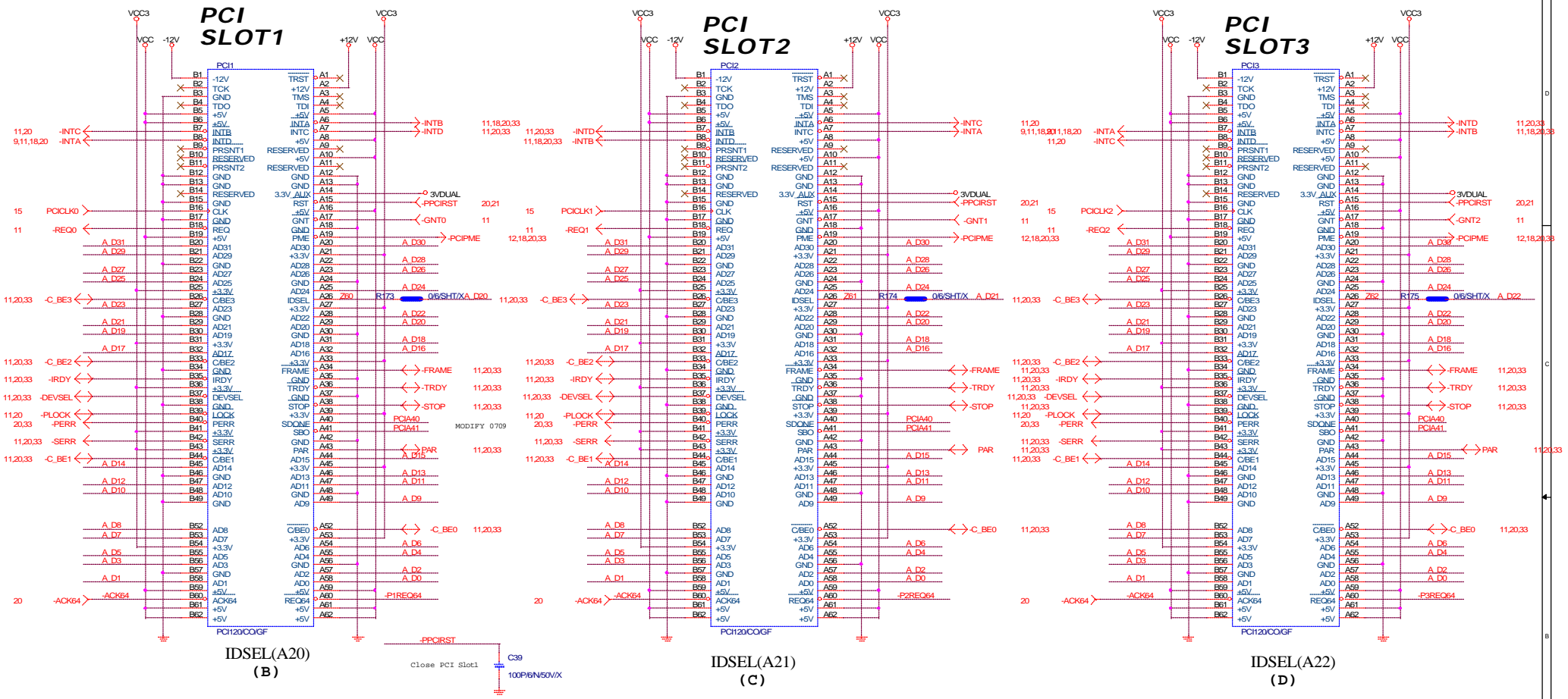

IDSEL(A20)
(B)

IDSEL(A21)
(C)

IDSEL(A22)
(D)

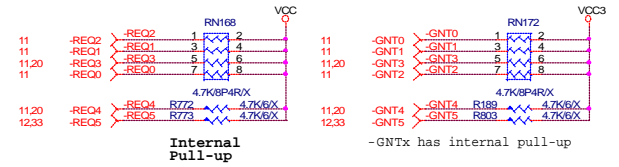

Internal Pull-up

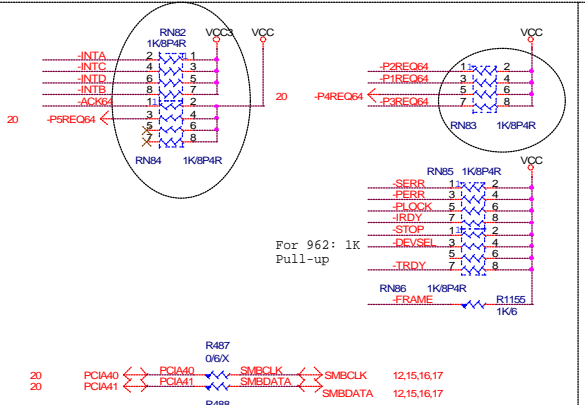

For 962: 1K Pull-up

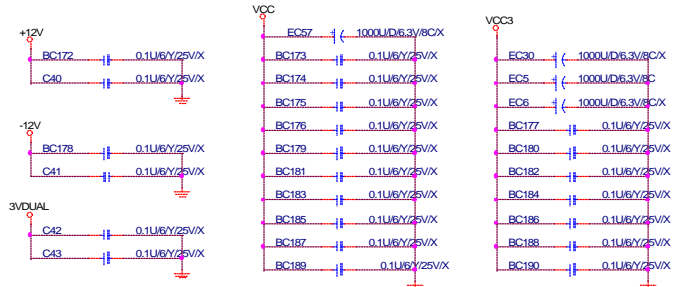

GIGABYTE

PCI SLOT 1,2,3

Title	PCI SLOT 1,2,3		Rev	1.0
Size	Custom	Document Number	GA-8ST800	
Date	Wednesday, December 25, 2002	Sheet	19	of 33

PCI SLOT 4,5,6

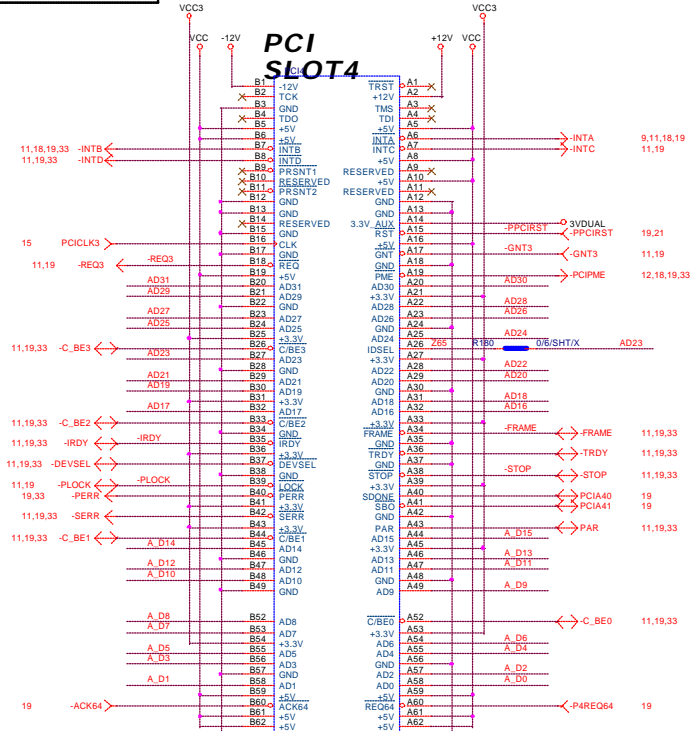

IDSEL(A23)
(A)

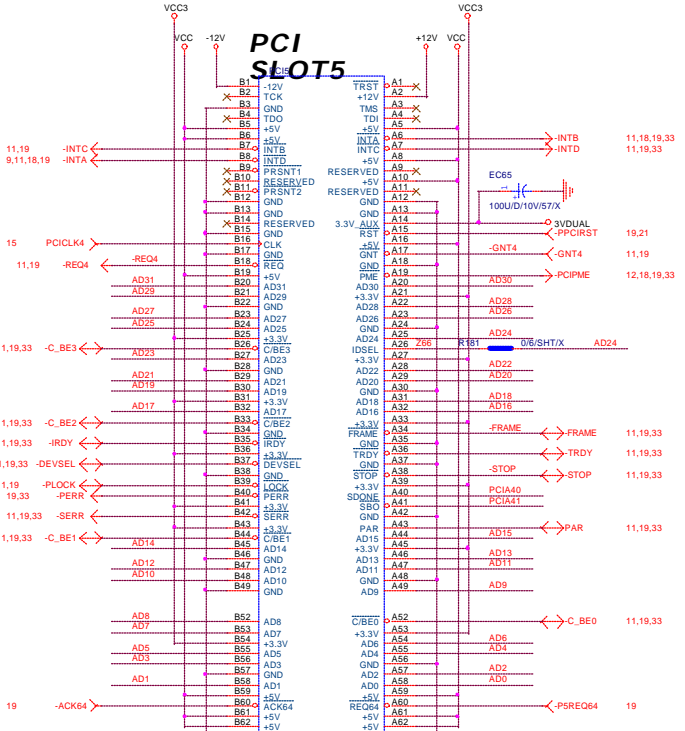

IDSEL(A24)
(B)

-PPCIRST
Close PCI Slot5
C44
100pF/N50V/X

Damping R Between PCI4 & PCI5

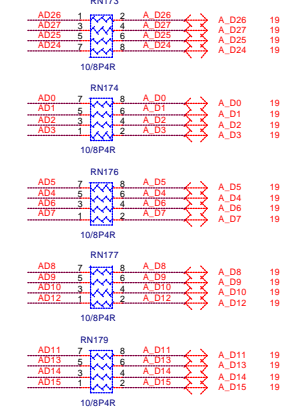

PCI add Damping Resistor for AHA2940U2W issue

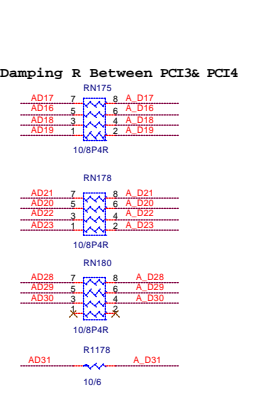

如果RTL8100BL未上

PCI的走線要盡量避免走"π"型。

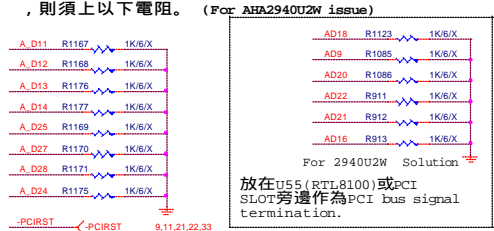

，則須上以下電阻。(For AHA2940U2W issue)

放在U55(RTL8100)或PCI SLOT旁邊作為PCI bus signal termination.

	INTA#	IDSEL	REQX-
PCI1	BCDA	AD20	REQ0
PCI2	CDAB	AD21	REQ1
PCI3	DABC	AD22	REQ2
PCI4	ABCD	AD23	REQ3
PCI5	BCDA	AD24	REQ4
RTL8100	D	AD26	REQ5

GIGABYTE

File: **PCI SLOT 4,5**

Size: Document Number

Custom: **GA-8ST800**

Date: Wednesday, December 25, 2002 Sheet 20 of 33

Rev: **1.0**

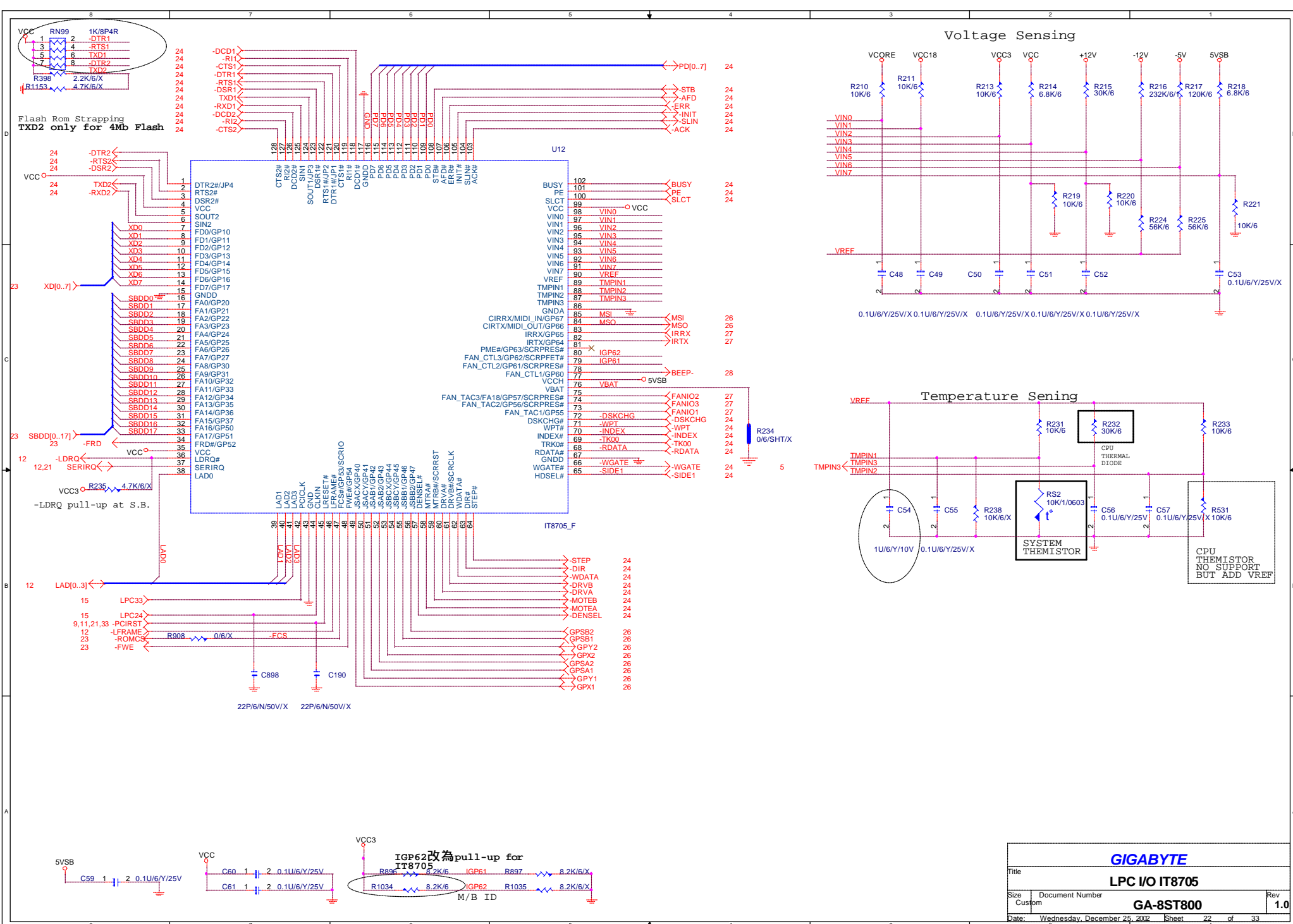

Voltage Sensing

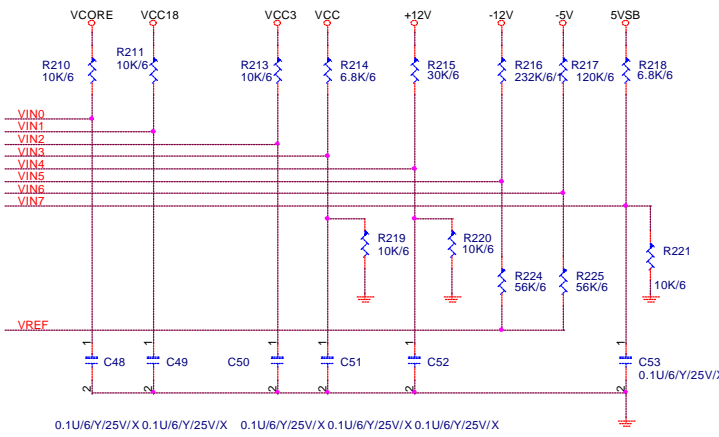

Temperature Sensing

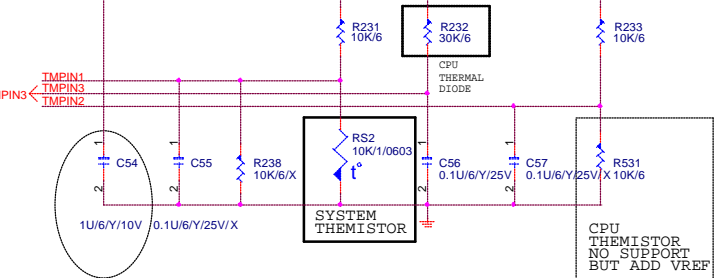

IGP62改為pull-up for IT8705
 R896 8.2K/6 IGP61 R897 8.2K/6/X
 R1034 8.2K/6 IGP62 R1035 8.2K/6/X
 M/B ID

GIGABYTE		
Title LPC I/O IT8705		
Size Custom	Document Number GA-8T800	Rev 1.0
Date: Wednesday, December 25, 2002 Sheet 22 of 33		

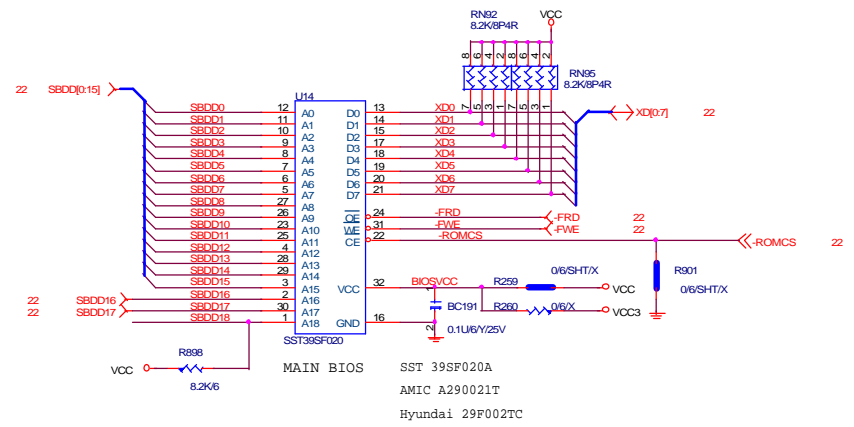

GIGABYTE		
Flash ROM		
Title		
Size	Document Number	Rev
Custom	GA-8ST800	1.0
Date:	Wednesday, December 25, 2002	Sheet 23 of 33

COM A, B

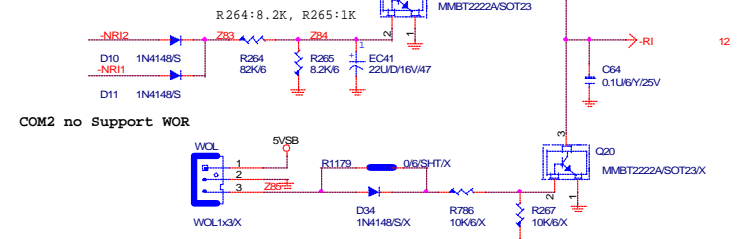
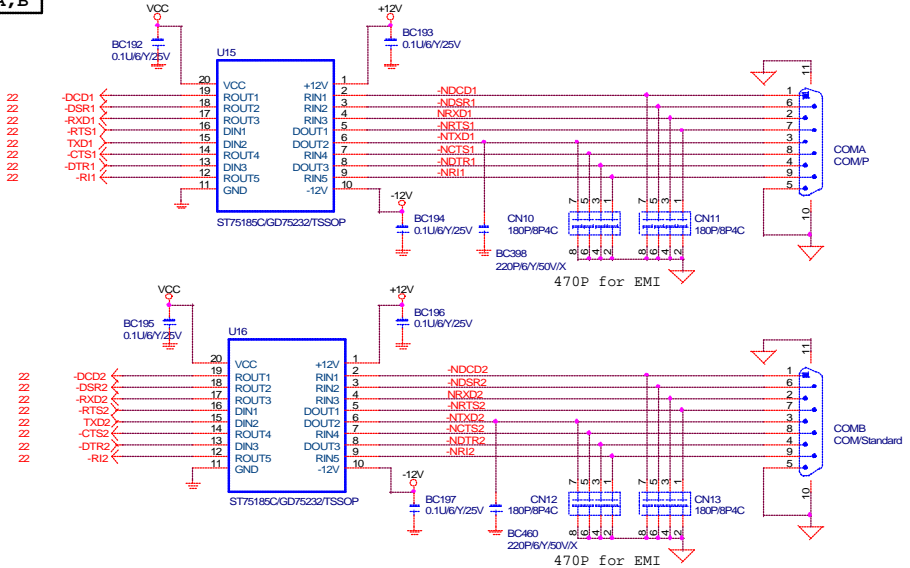

LPT

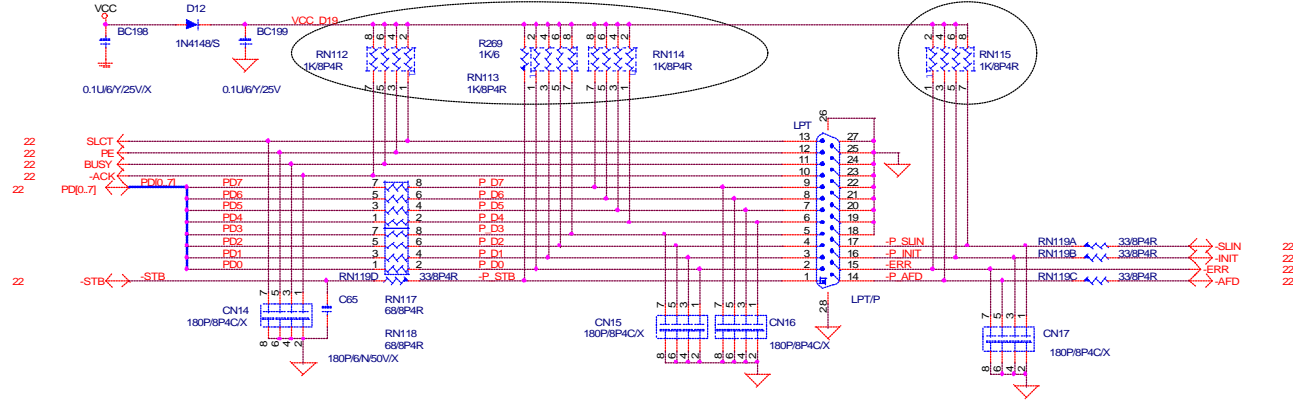

FDD

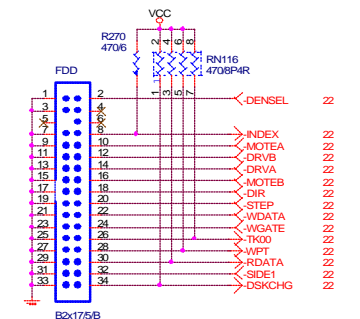

KBC/PS2

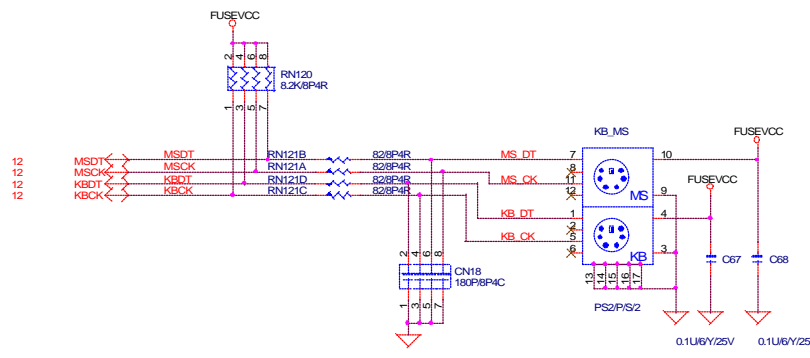

GIGABYTE		
Title COM,PRT,FDD,KB,IR		
Size Custom	Document Number GA-8ST800	Rev 1.0
Date: Wednesday, December 25, 2002	Sheet	21 of 33

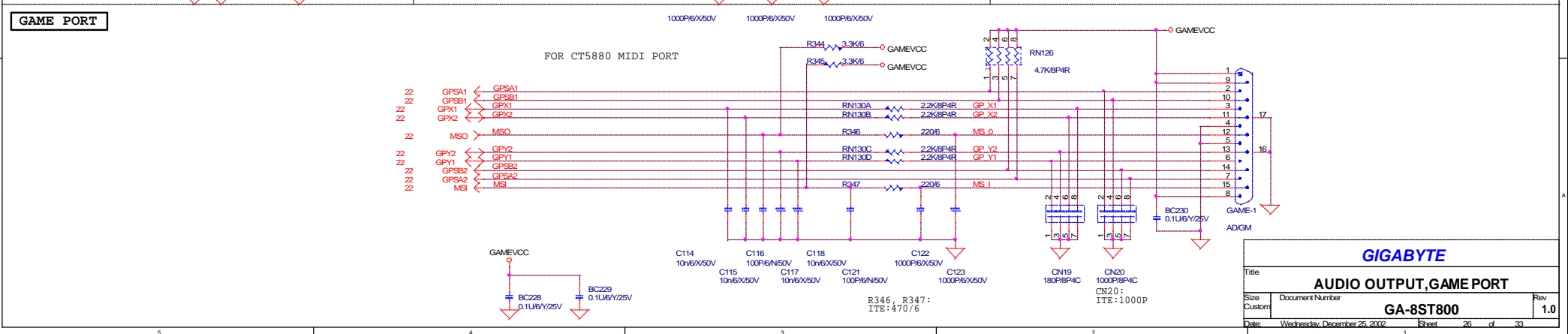
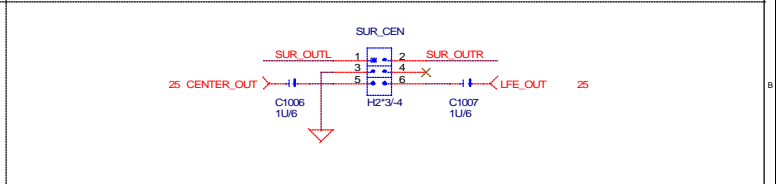
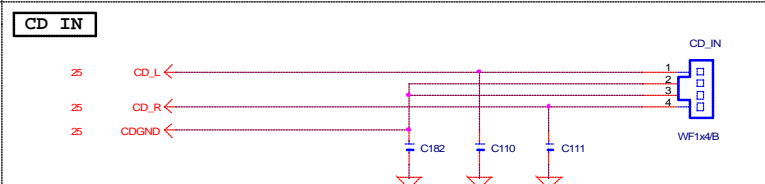
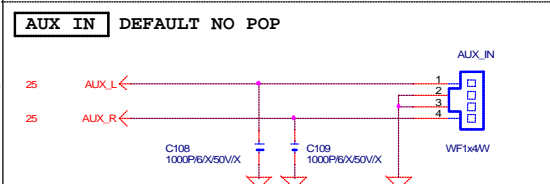
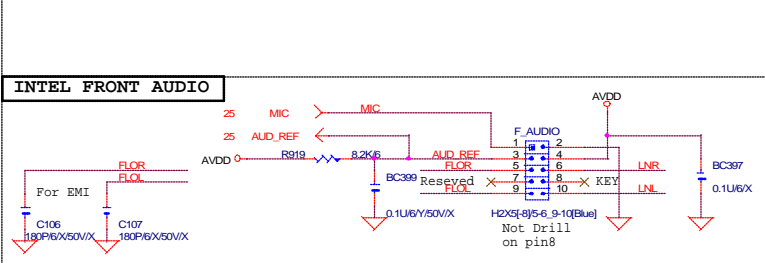
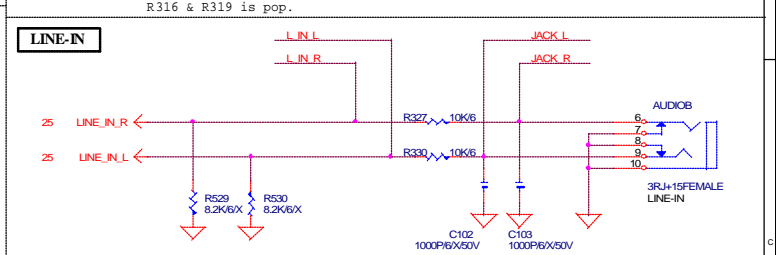
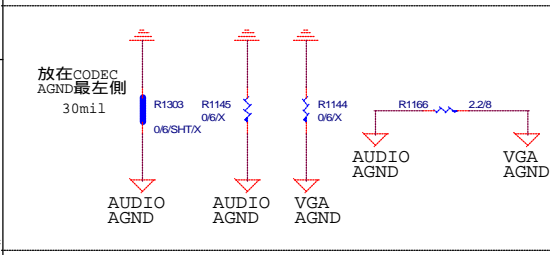
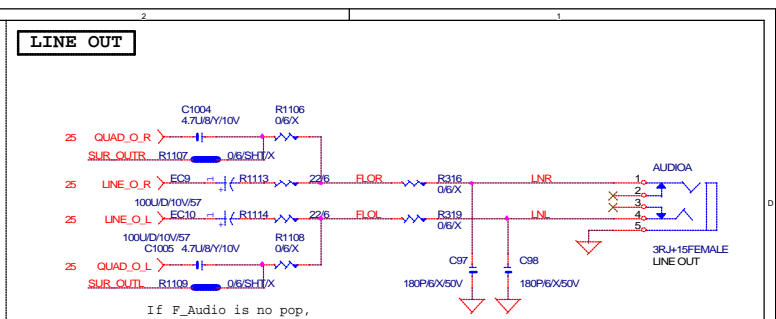
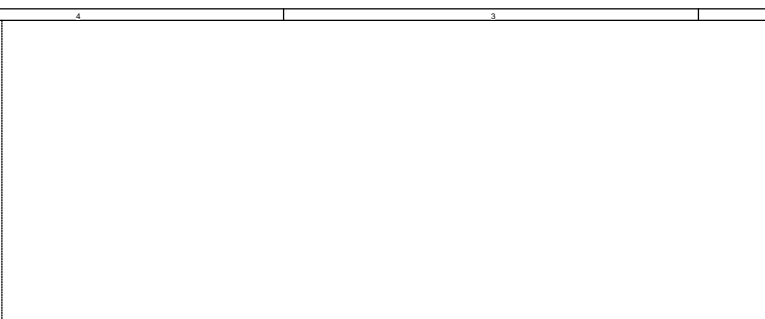
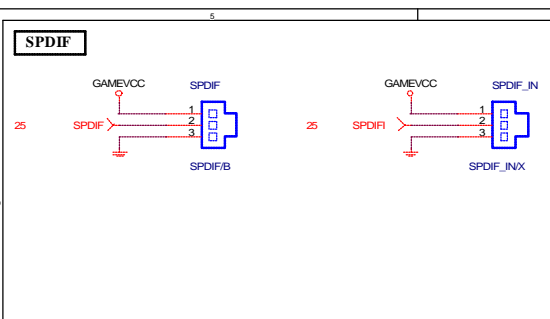

GIGABYTE		
Title: AUDIO OUTPUT, GAME PORT		
Size: Custom	Document Number: GA-8ST800	Rev: 1.0
Date: Wednesday, December 25, 2002	Sheet: 26	of 33

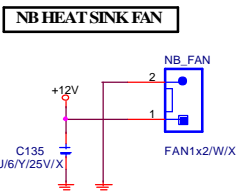
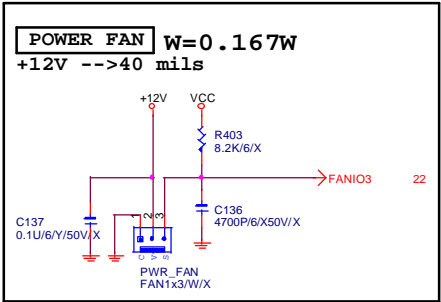
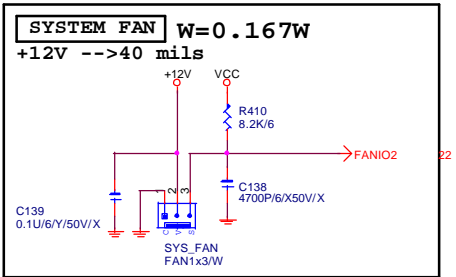
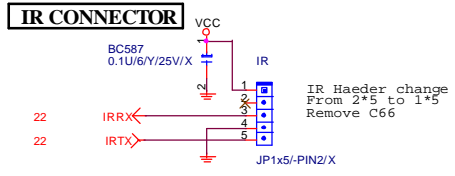
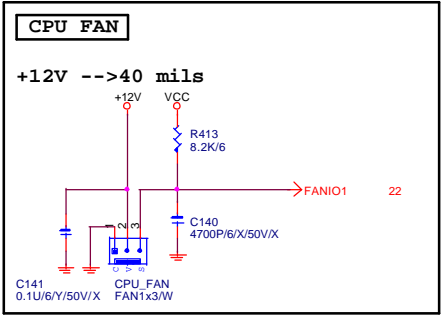

GIGABYTE		
FAN		
Title	Document Number	Rev
Size Custom	GA-8ST800	1.0
Date:	Wednesday, December 25, 2002	Sheet 27 of 33

FRONT PANEL

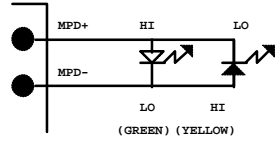

States for a single-color power LED

LED States	ACPI States	MPD+	MPD-
OFF	S1,S3,S5	HI	HI
Steady Green	S0	HI	LO
Blinking Green	S0(message waiting)	HI	BLINKING

States for a dual-color power LED

LED States	ACPI States	MPD+	MPD-
OFF	S5	HI	HI
Steady Green	S0	HI	LO
Blinking Green	S0(message waiting)	HI	BLINKING
Steady Yellow	S1,S3	LO	HI
Blinking Yellow	S1,S3(message waiting)	LO	BLINKING

	S0	S1	S3	S5
GPIO11(GLED-)	0	1	1	0
GPIO7(SUSLED)	0	B	B	0
ACPILED(Pin A15)	0	0	0	1

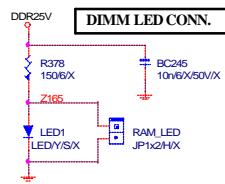
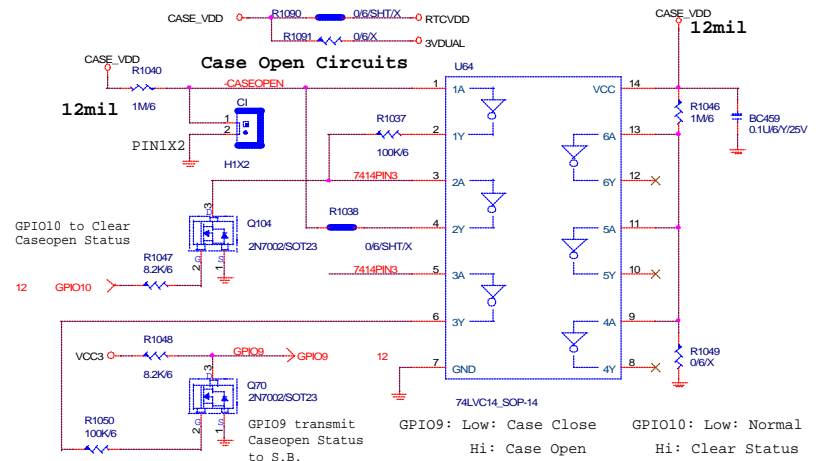
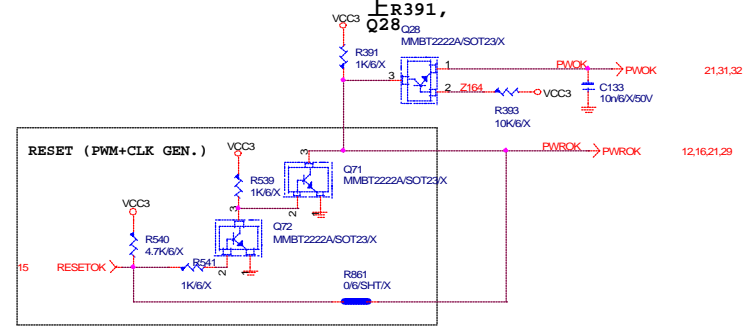
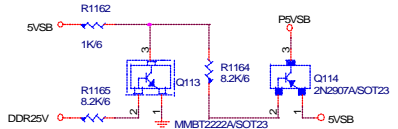
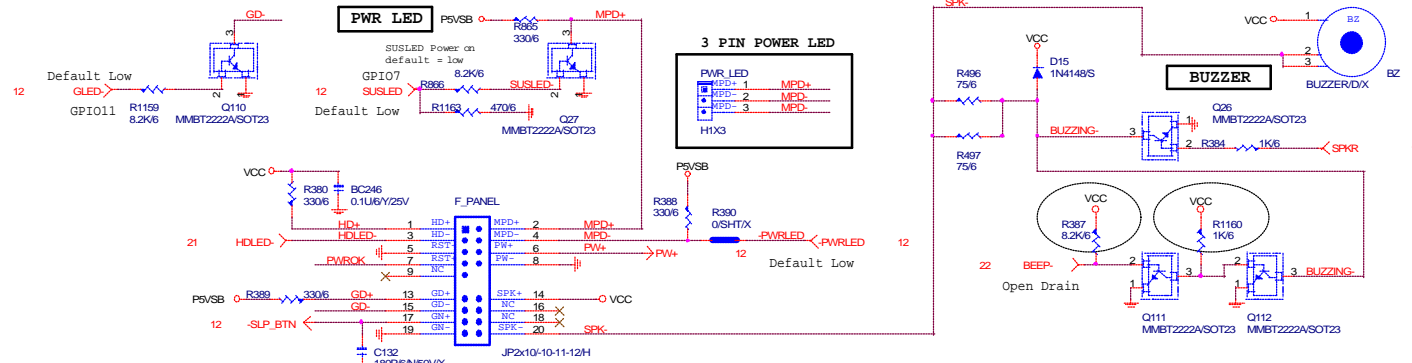

74LVC14:
10TC1-140014-01
10TC1-120014-01
10TC1-120014-02

GIGABYTE		
PANEL, STR LED		
Title		
Size	Document Number	Rev
Custom	GA-8ST800	1.0
Date:	Wednesday, December 25, 2002	Sheet 28 of 33

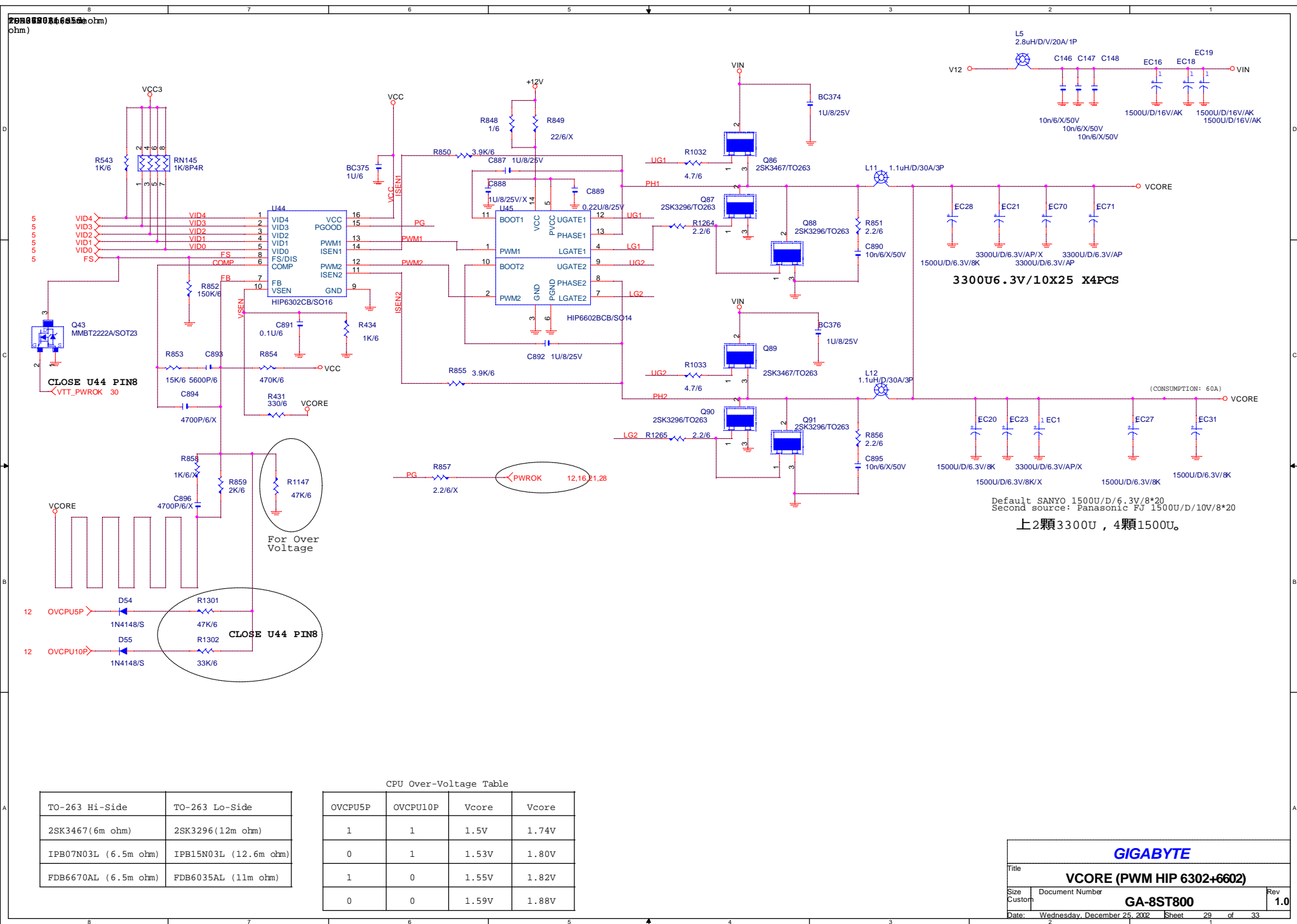

3300U.6.3V/10X25 X4PCS

Default SANYO 1500U/D/6.3V/8*20
 Second source: Panasonic FJ 1500U/D/10V/8*20
 上2顆3300U, 4顆1500U.

CPU Over-Voltage Table

OVCPU5P	OVCPU10P	Vcore	Vcore
1	1	1.5V	1.74V
0	1	1.53V	1.80V
1	0	1.55V	1.82V
0	0	1.59V	1.88V

TO-263 Hi-Side	TO-263 Lo-Side
2SK3467 (6m ohm)	2SK3296 (12m ohm)
IPB07N03L (6.5m ohm)	IPB15N03L (12.6m ohm)
FDB6670AL (6.5m ohm)	FDB6035AL (11m ohm)

GIGABYTE

Title: **VCORE (PWM HIP 6302+6602)**

Size: Custom Document Number: **GA-8ST800** Rev: **1.0**

Date: Wednesday, December 25, 2002 Sheet 29 of 33

SB18 FOR SB

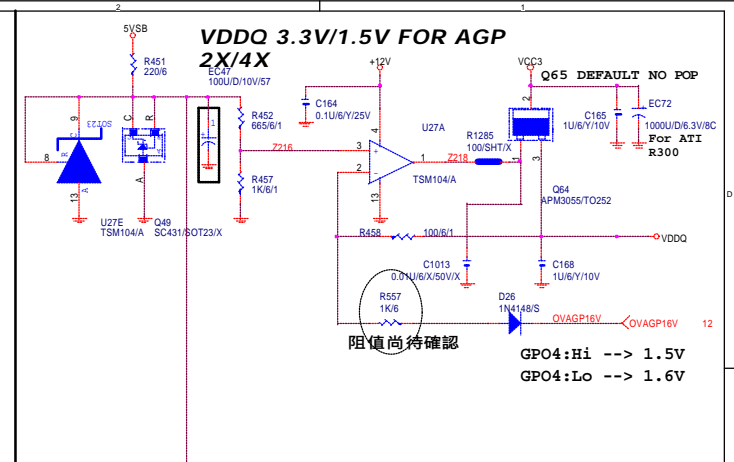
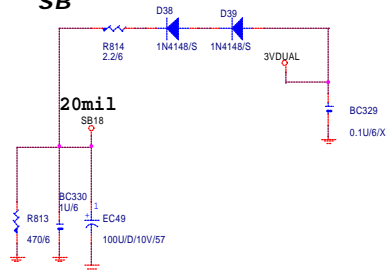

VCC18 FOR NB,SB

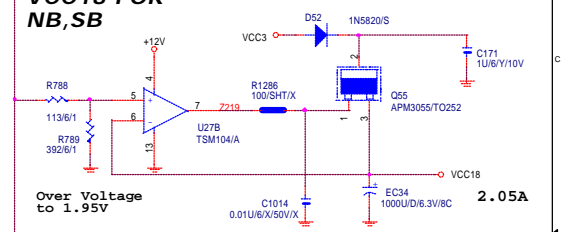

VCCVID FOR NORTHWOOD CPU

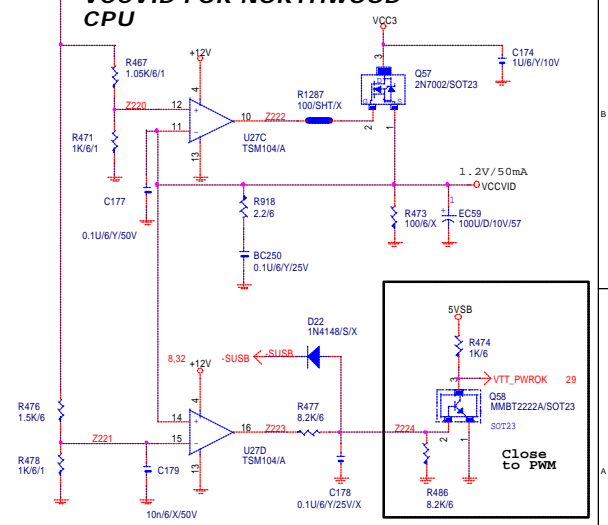

GIGABYTE		
Title VDDQ, VCCVID, 3VDUAL		
Size Custom	Document Number GA-8ST800	Rev 1.0
Date: Wednesday, December 25, 2002	Sheet	30 of 33

ATX CONN, DC POWER

ATX POWER CONNECTOR

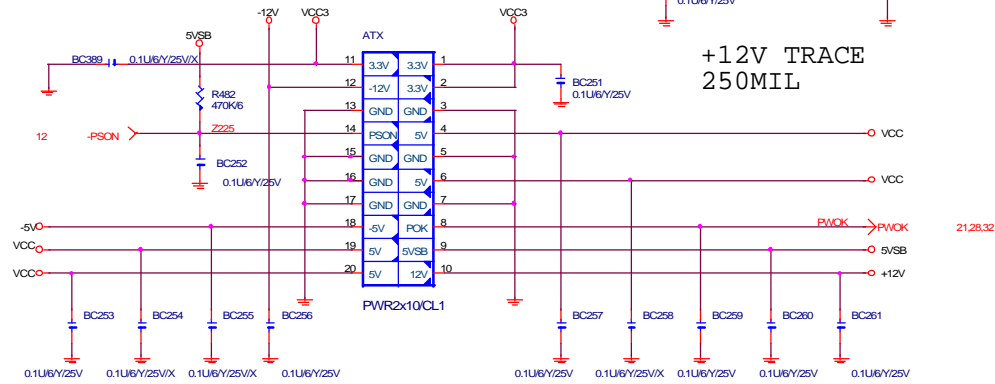

8SRXL South Bridge GPIO LIST			
ITEM	DESCRIPTION	STATUS	Default
GP00	Non Use		Hi
GP01	Non Use		Hi
GP04	Non Use		Hi
GP02	Non Use		Hi
GP03	Green Button	Hi:Normal, Lo:Into Green mode	Hi
GPIO5	REQ5		
GPIO6	GNT5		
GP07	Non Use		Hi
GP011	Non Use		Hi
GP18	Wake On Ring	Hi:Normal, Lo:Ring Power On	Hi
GP19	Case Open	Hi:Case Open, Lo:Normal	Lo
GP110	Clear Caseopen status	Hi:Clear Caseopen Status, Lo:Normal	Lo
GP113	Non Use		Hi
GP012	Non Use		Hi
GP114	Primary Down	Lo:CODEC Only	Lo
GPIO15	KB Data		Hi
GPIO16	KB Clk		Hi
GPIO17	MS Data		Hi
GPIO18	MS Clk		Hi

States for a single-color power LED

LED States	ACPI States	BIOS			
		MPD+	MPD-	GPIO7	ACPILED
OFF	S5	HI	HI	LO	HI/NC
Steady Green	S0	HI	LO	LO	LO
Blinking Green	S0(message waiting)	HI	BLINKING	LO	BLINKING

States for a dual-color power LED

LED States	ACPI States	BIOS			
		MPD+	MPD-	GPIO7	ACPILED
OFF	S5	HI	HI	LO	HI/NC
Steady Green	S0	HI	LO	LO	LO
Blinking Green	S0(message waiting)	HI	BLINKING	LO	BLINKING
Steady Yellow	S1,S3	LO	HI	HI	HI
Blinking Yellow	S1,S3(message waiting)	LO	BLINKING	HI	BLINKING

States for green LED

LED States	ACPI States	BIOS	
		GLLED-	GPIO11
ON	S1,S3	HI	HI
OFF	S0,S5	LO	LO

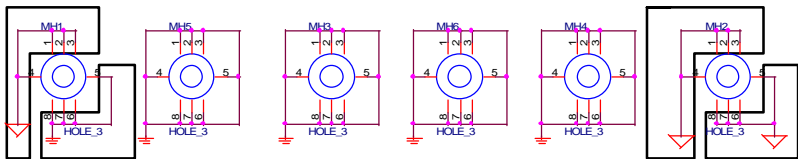
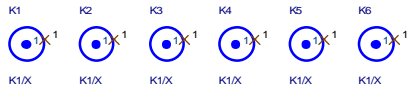

EMI (VCC.GND CUT HOLE PLANE)

EMI (VCC.LGND CUT HOLE PLANE)

BIOS REQUEST

SINGLE	DUAL	INTEL LED DEFINED				GIGABYTE LED DEFINED				SINGLE	DUAL
		GPIO7	ACPILED	GPIO11		GPIO7	ACPILED	GPIO11			
GREEN	GREEN	S0	LO	LO	LO	S0	LO	LO	LO	GREEN	GREEN
OFF	YELLOW	S1	HI	HI	HI	S1	LO	BLINKING	HI	G(BLINK)	G(BLINK)
OFF	YELLOW	S3	HI	HI	HI	S3	HI	HI	HI	OFF	YELLOW
OFF	OFF	S4/S5	LO	HI/NC	LO	S4/S5	LO	HI/NC	LO	OFF	OFF

GIGABYTE

Title			ATX, GPIO LIST		
Size	Document Number	Rev			
Custom	GA-8ST800	1.0			
Date:	Wednesday, December 25, 2002	Sheet	31	of	33

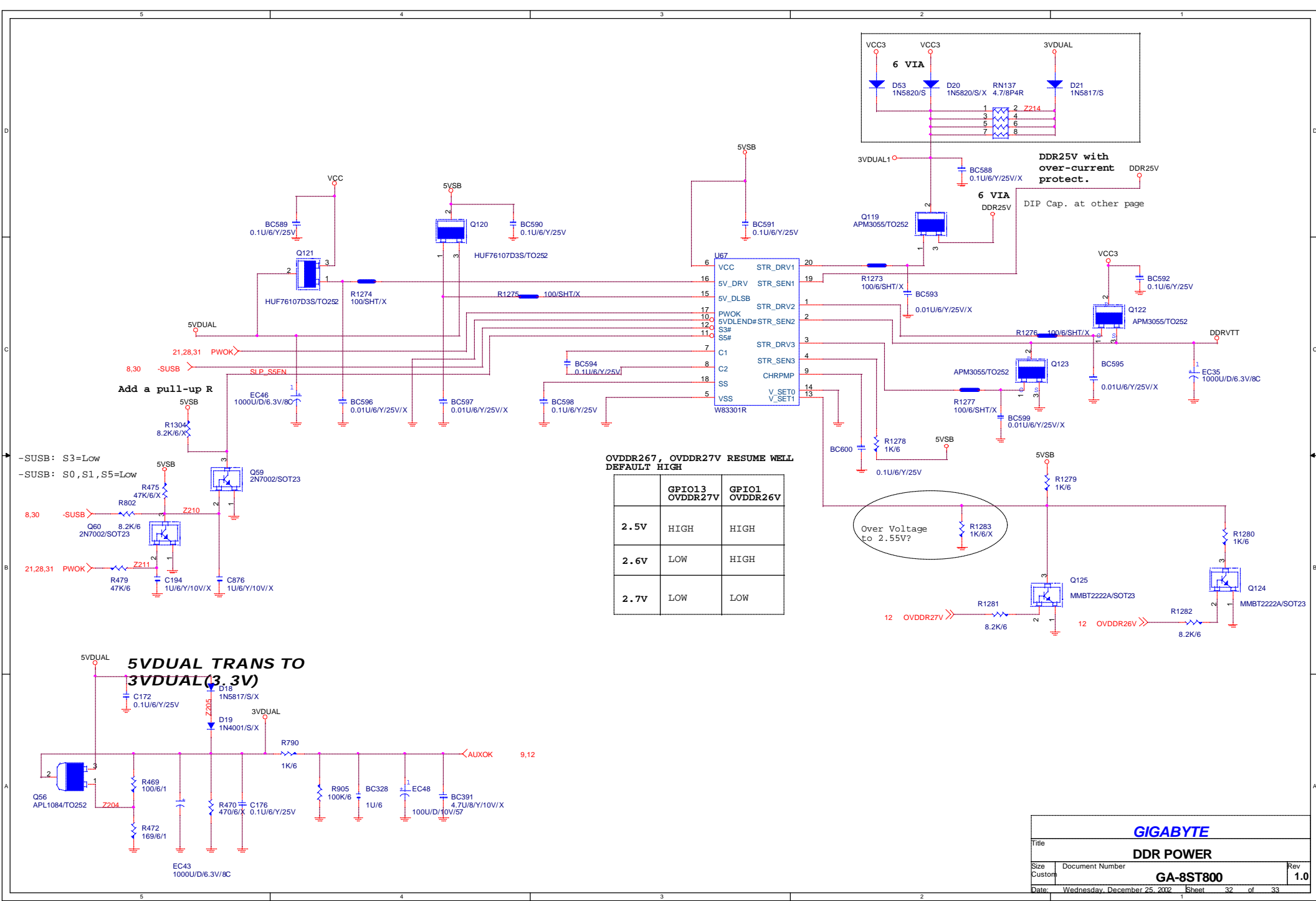

Add a pull-up R

-SUSB: S3=Low
-SUSB: S0, S1, S5=Low

OVD27V, OVD26V RESUME WELL
DEFAULT HIGH

	GPIO13 OVD27V	GPIO1 OVD26V
2.5V	HIGH	HIGH
2.6V	LOW	HIGH
2.7V	LOW	LOW

Over Voltage
to 2.55V?

**5VDUAL TRANS TO
3VDUAL (3.3V)**

GIGABYTE

DDR POWER

Title	GA-8ST800		Rev	1.0
Size	Document Number			
Date:	Wednesday, December 25, 2002	Sheet	32	of 33

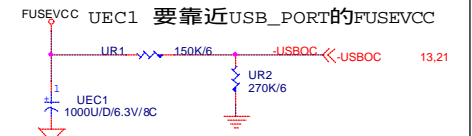
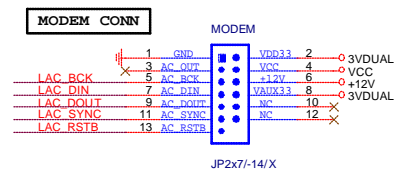
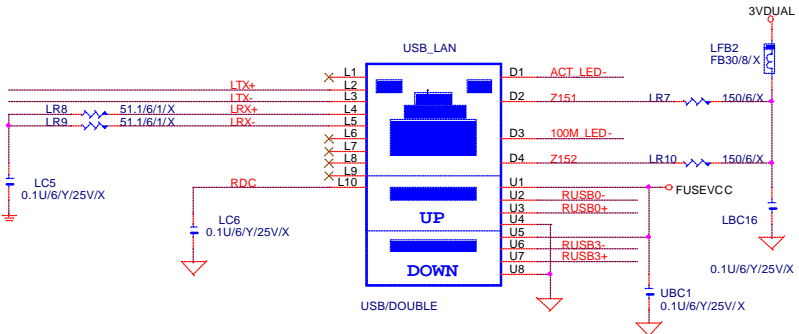
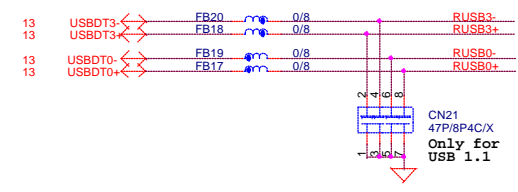
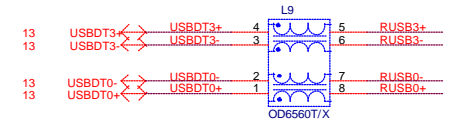
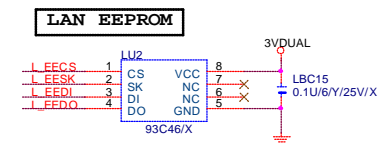
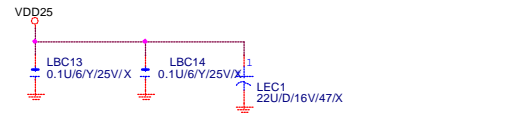
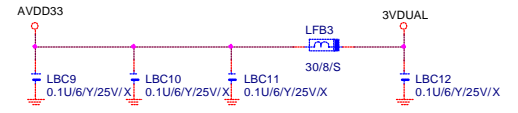
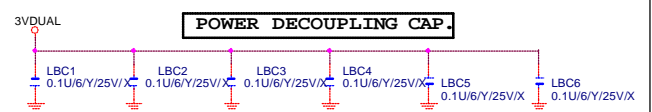
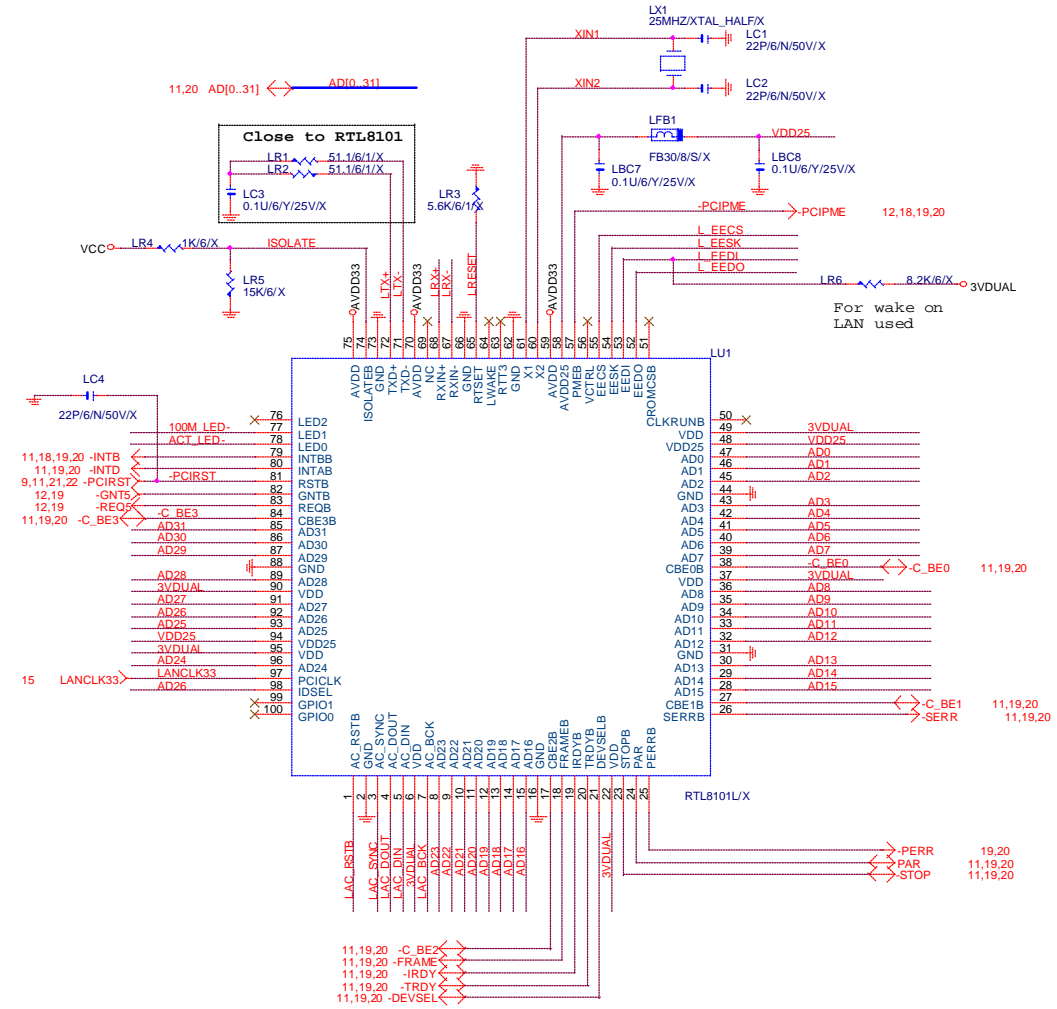

GIGABYTE		
LAN RTL8101L		
Title	Document Number	Rev
	GA-8ST800	1.0
Size Custom	Date: Wednesday, December 25, 2002	Sheet 33 of 33