

www.kynhvitinh.com

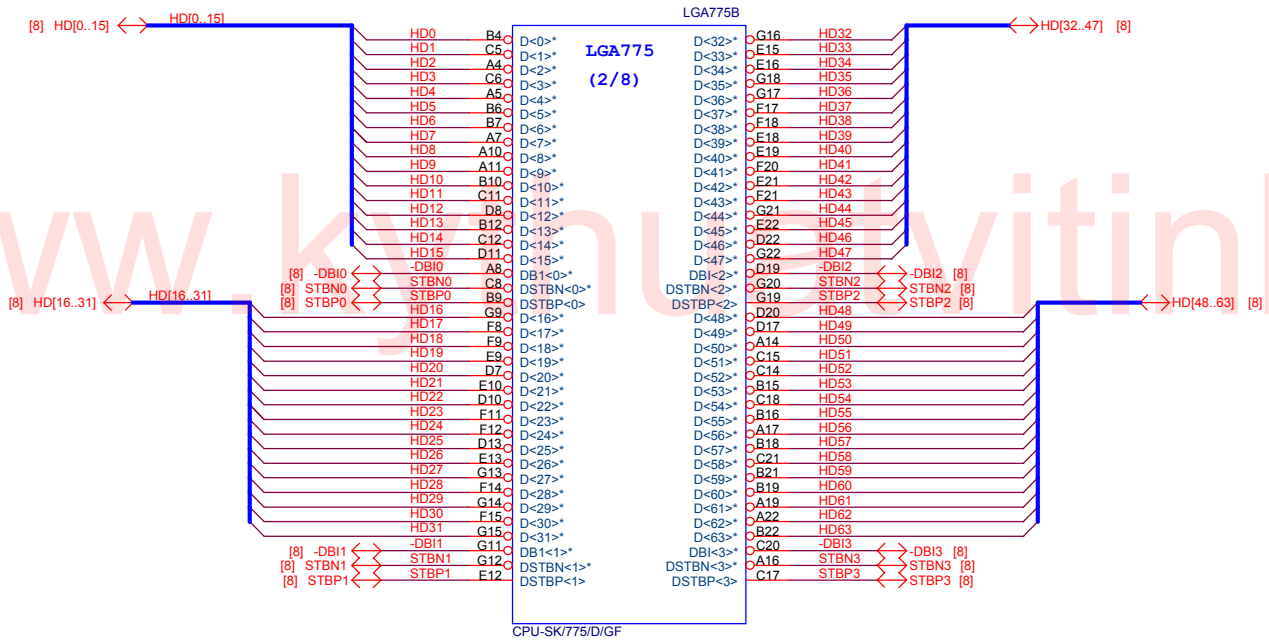

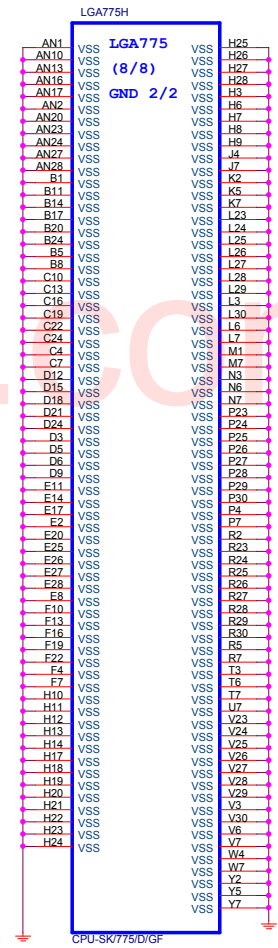

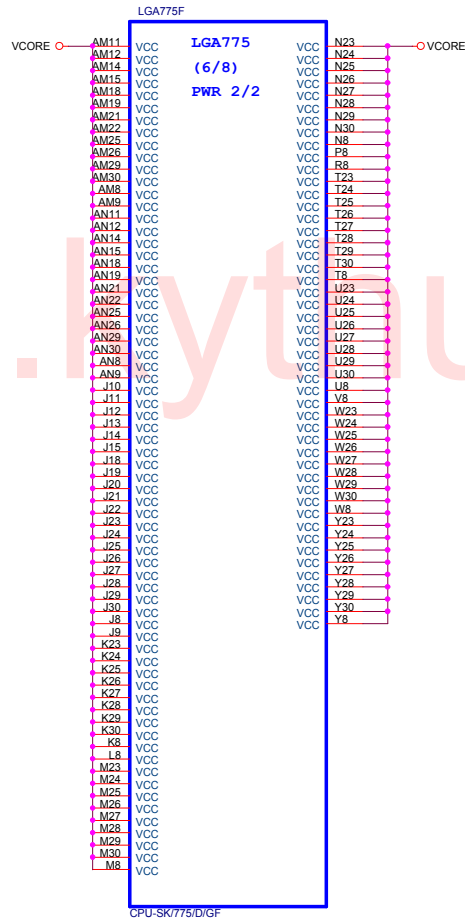
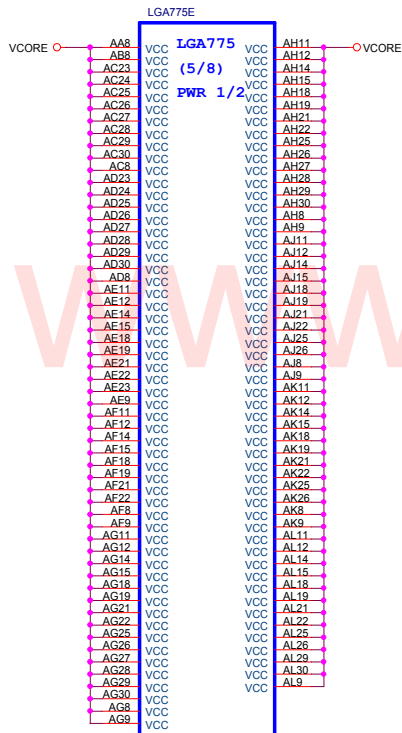
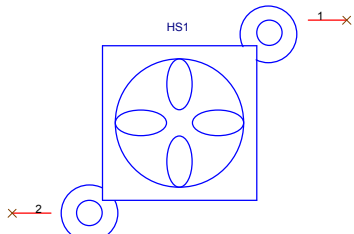

NB_HEATSINK[12SP2-04E003-A1R_12SP2-04E003-A2R_12SP2-04E003-A3R_12SP2-04E003-A4R]

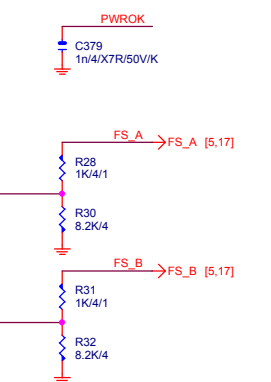
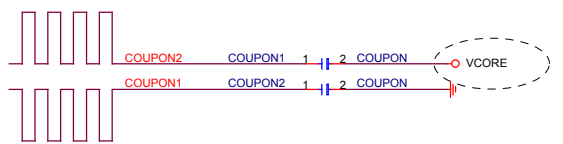
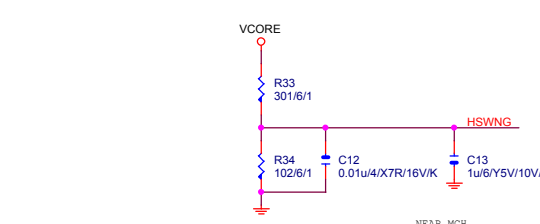
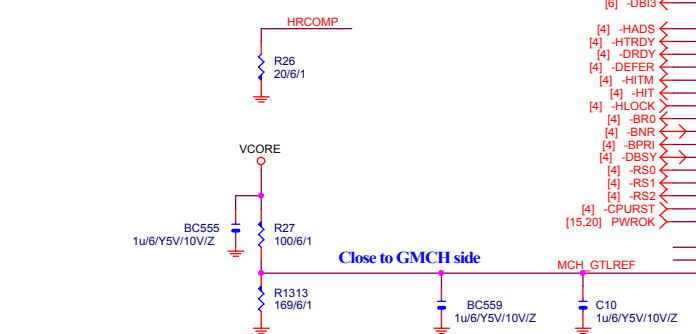
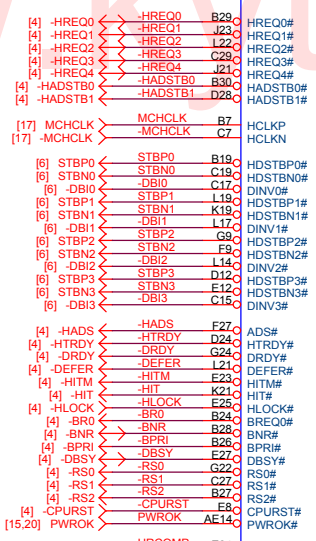
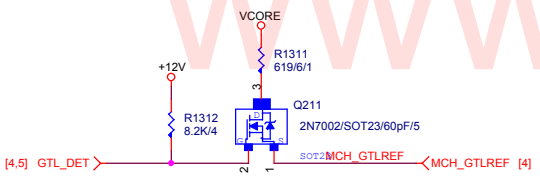
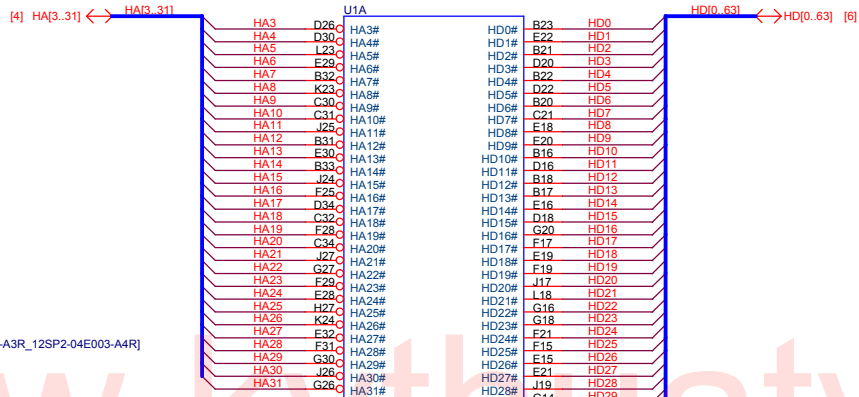

Title		
SPRINGDALE HOST		
Size	Document Number	Rev
Custom	81865GME-775-RH	2.0
Date:	Sheet 8 of 30	

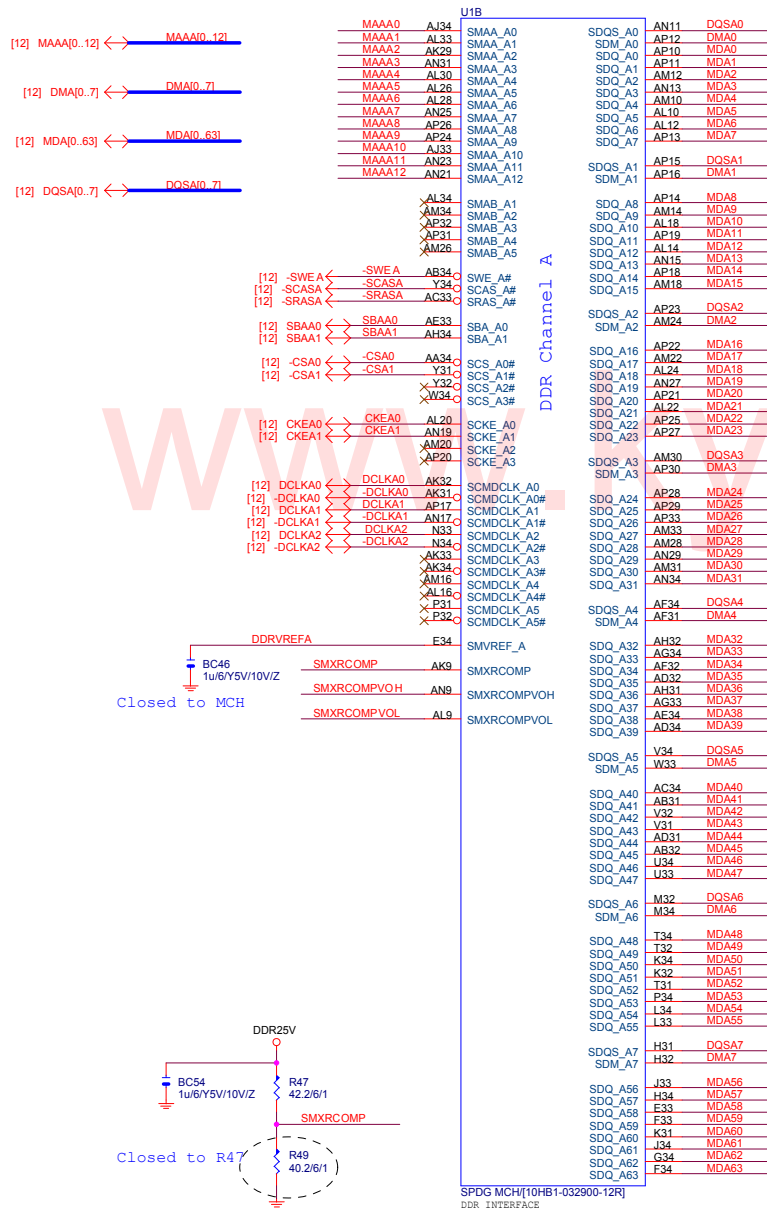

FIG 1.3V (PQI/TWINMOS DDR400) -->REV 1.0

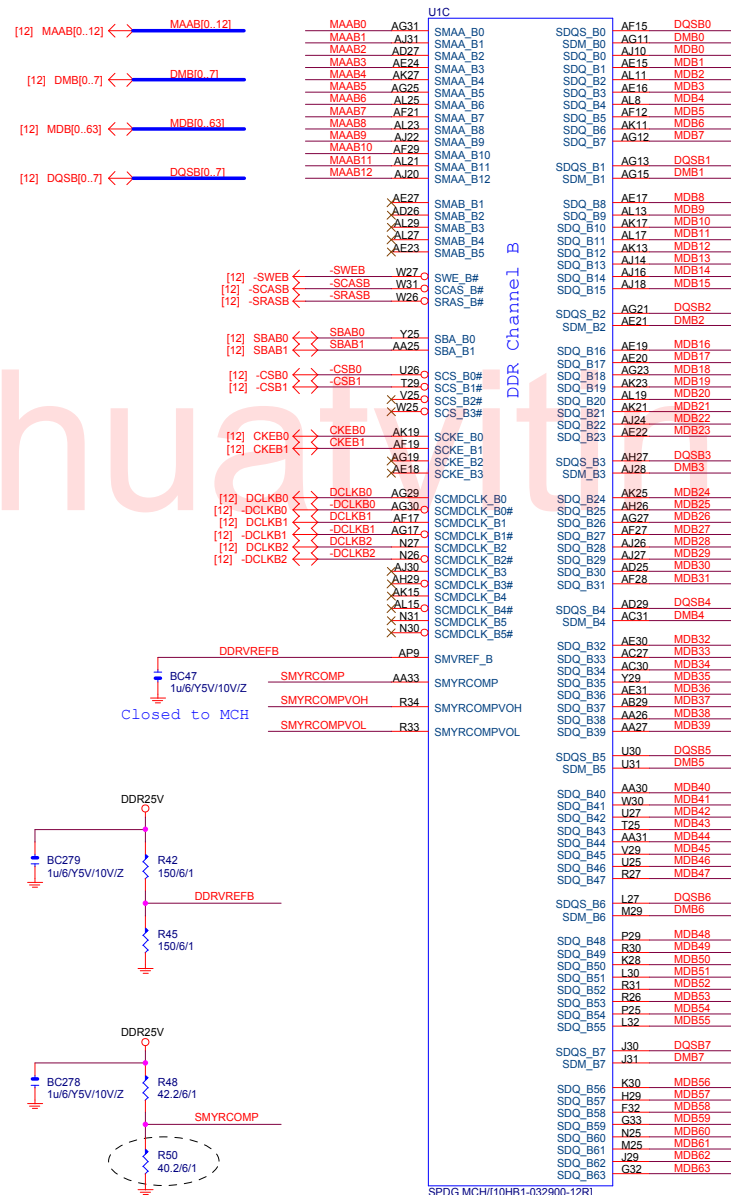
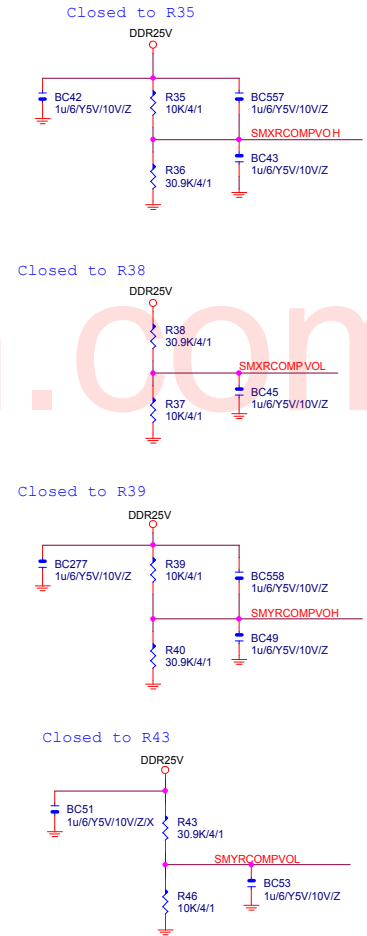
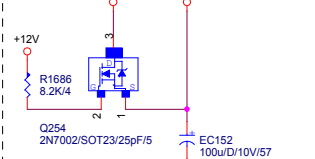

FIG 1.3V (PQI/TWINMOS DDR400) -->REV 1.0

DDR 400 1-2-3-4 CPC DISABLE
 DDR 333 SIGNAL 1 CPC ENABLE
 2 CPC DISABLE
 DUAL 2 CPC ENABLE
 DUAL 4 CPC DISABLE



close 北橋 (注意震盪水波紋)



2006.04.14 REV:1.1

2006.04.14 REV1.1

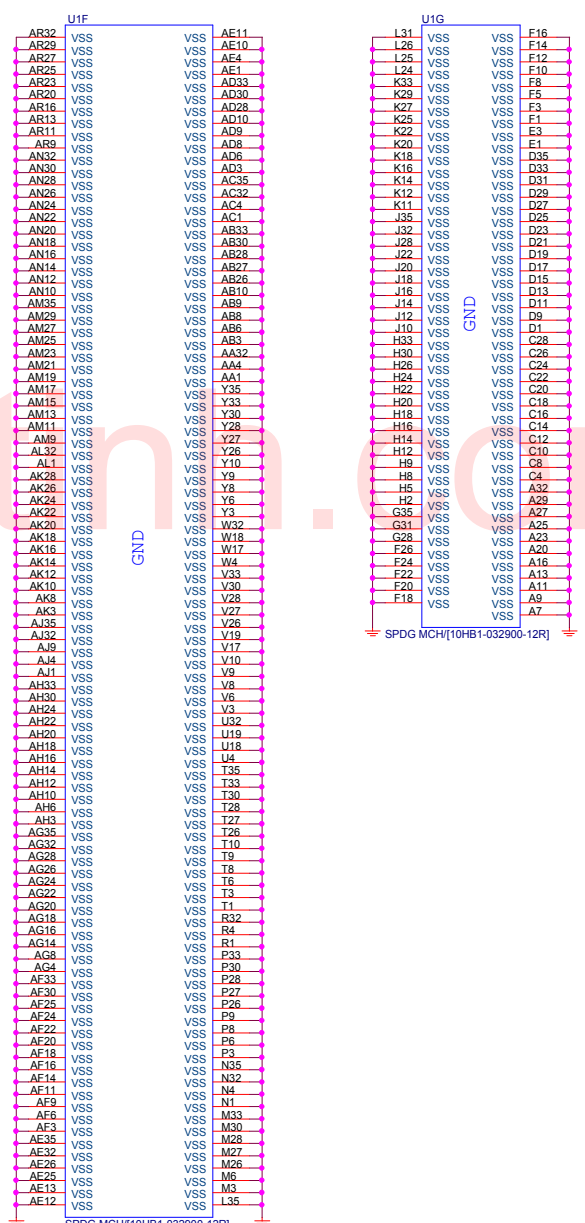
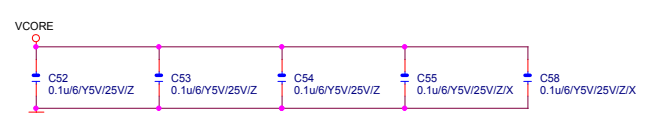
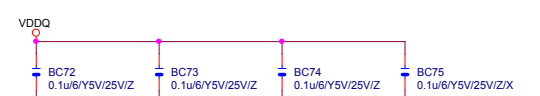
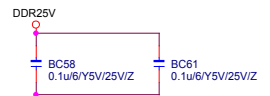
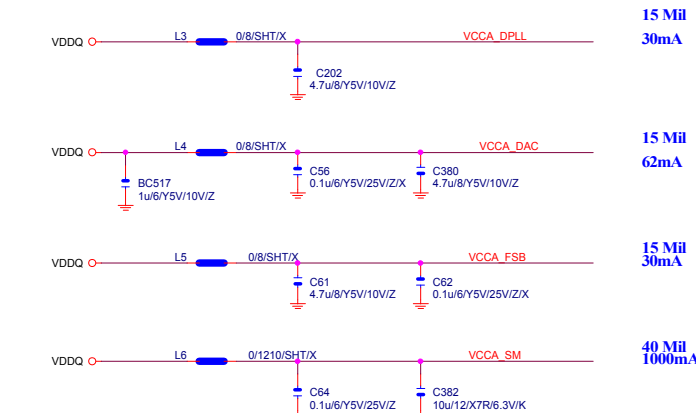
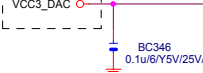

Title			SPRINGDALE PWR
Size	Document Number	81865GME-775-RH	
Custom			Rev 2.0
Date:		Sheet	11 of 30

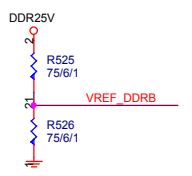
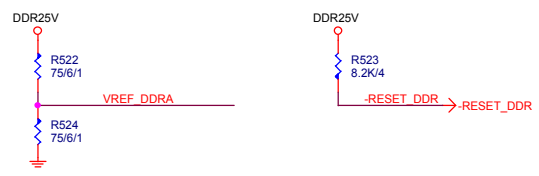
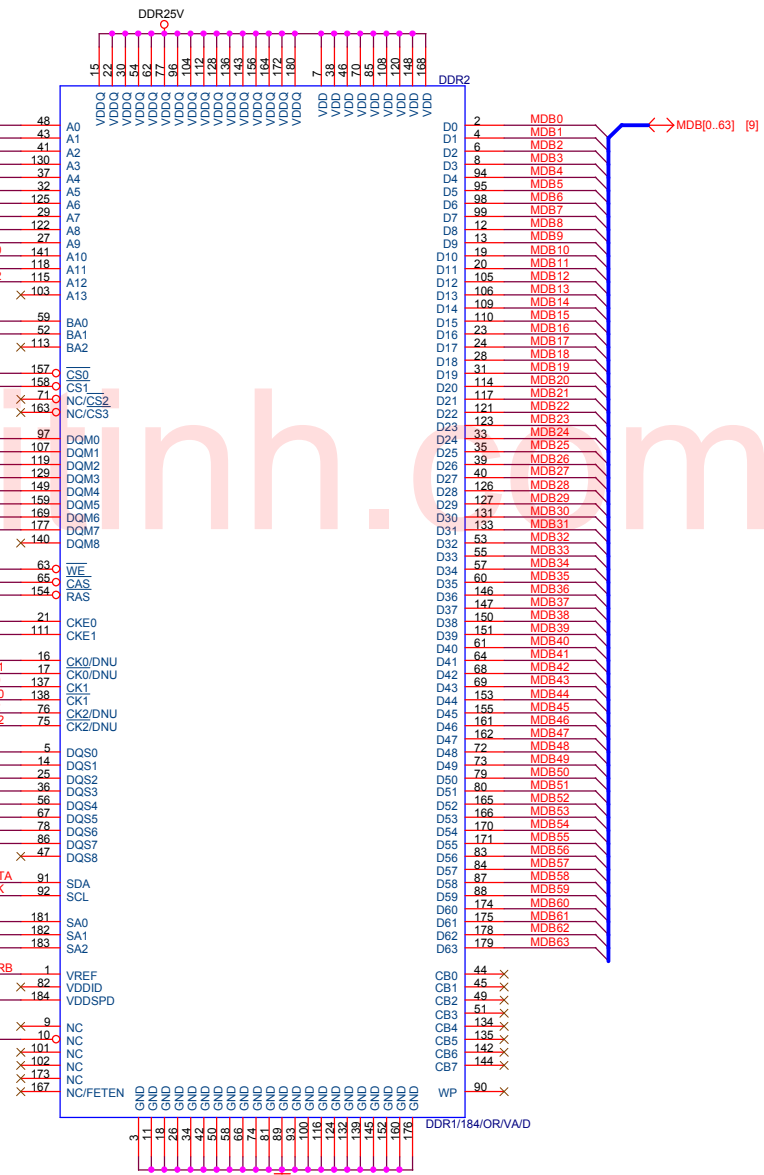
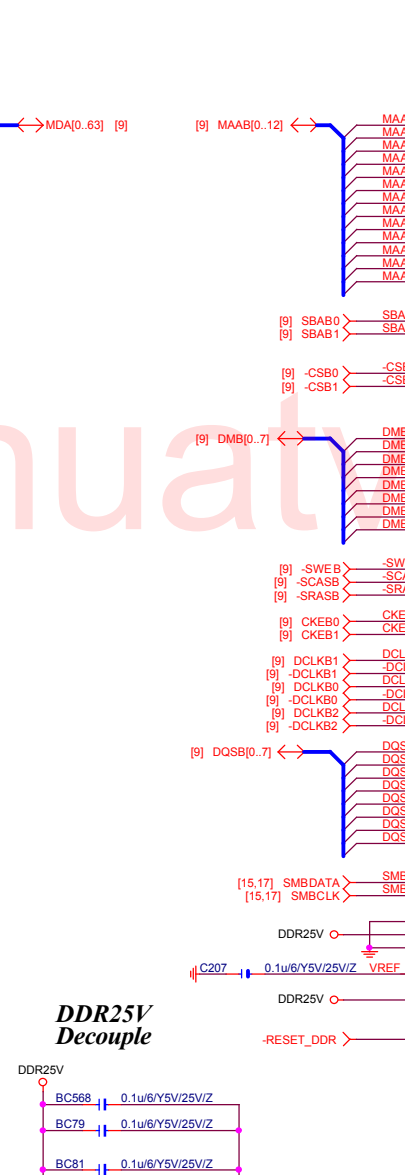
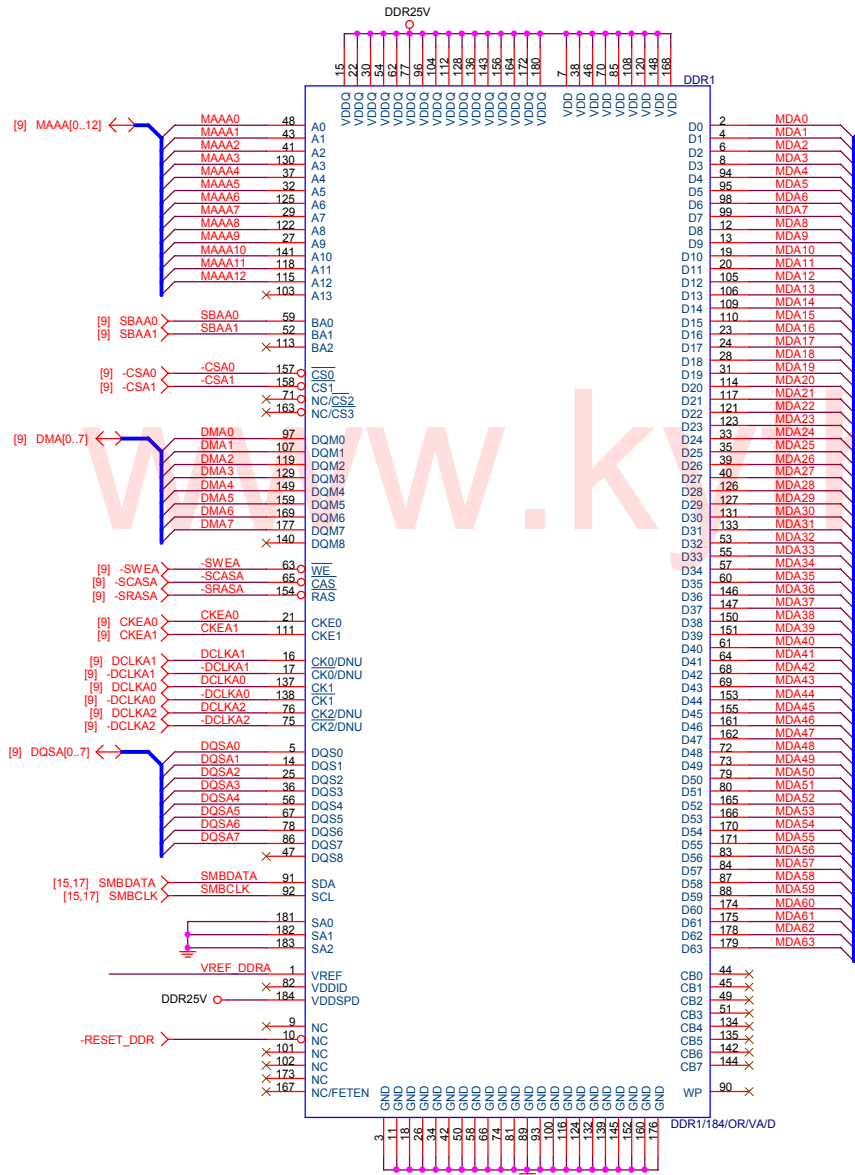

For Register DDR Support

SIGABYTE			
Title			
DDR1,2			
Size	Document Number	81865GME-775-RH	
Custom			Rev 2.0
Date:		Sheet	12 of 30

AGP SLOT

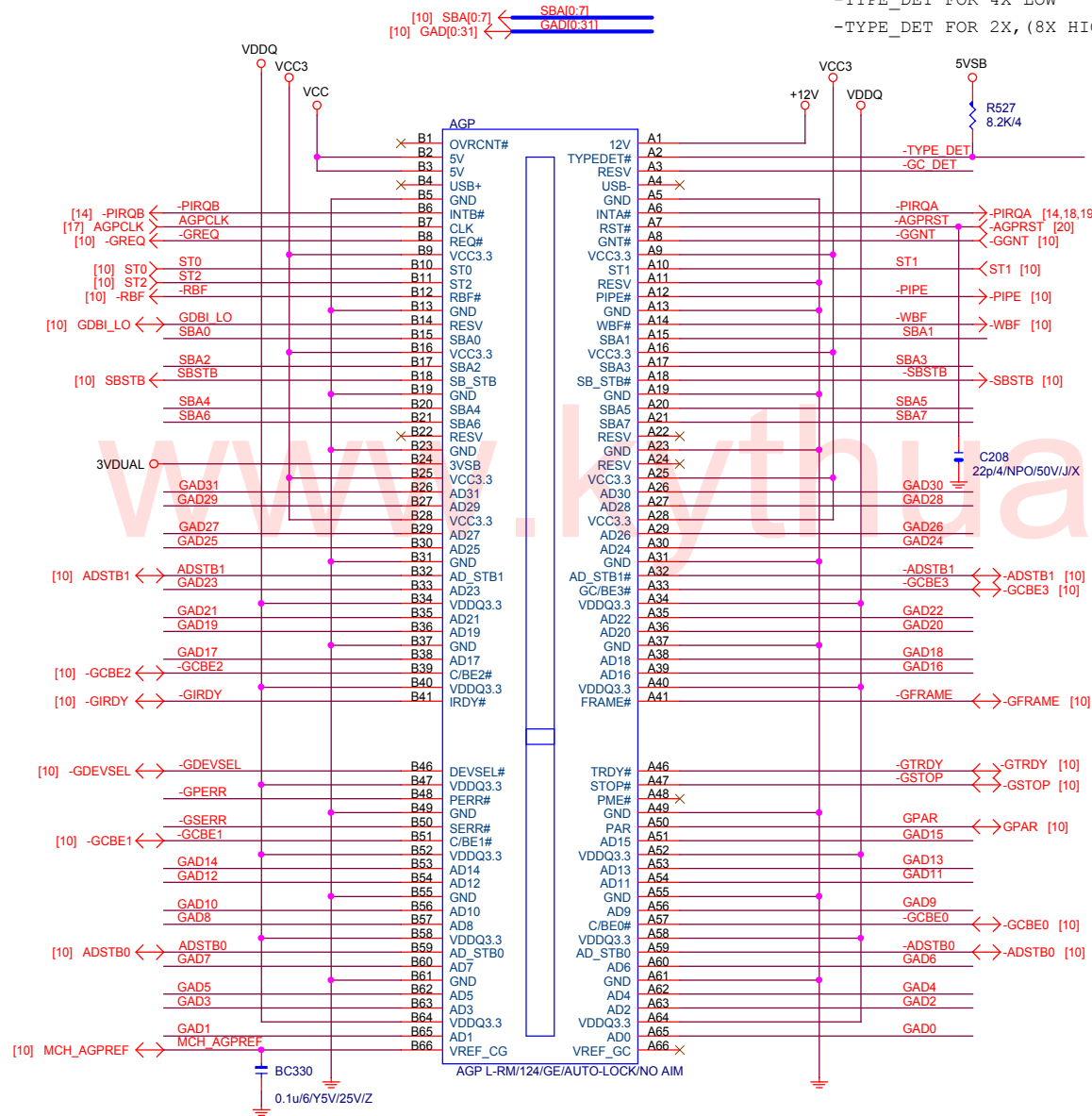

REF SCH

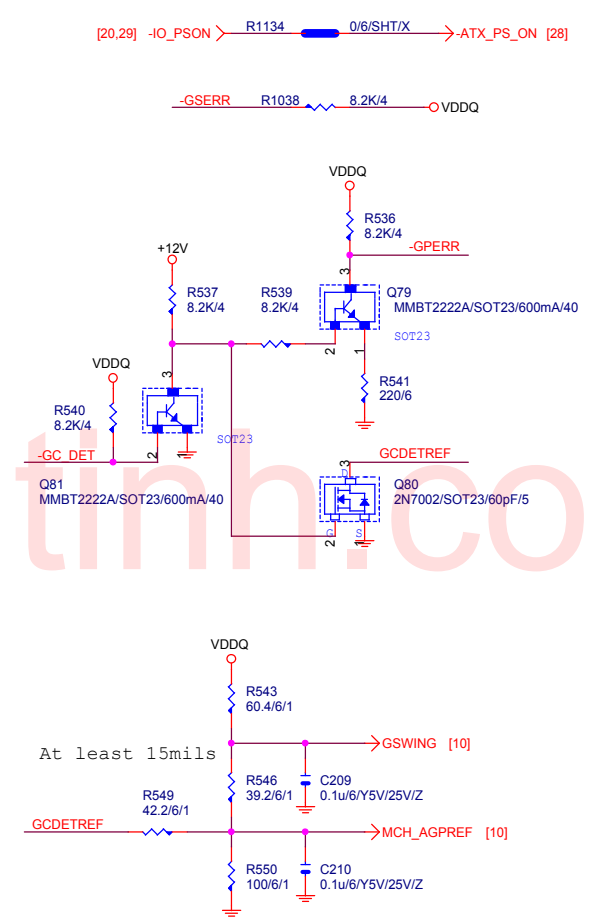

DE-CAP

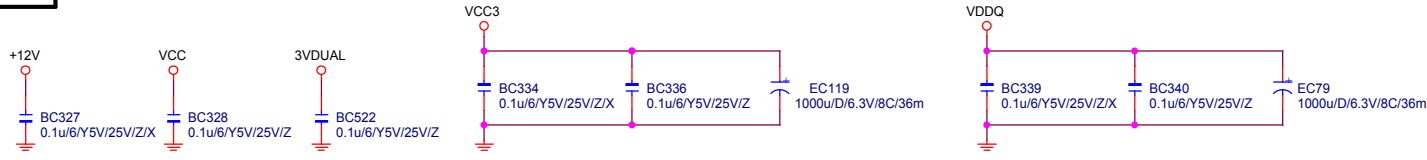

GIGABYTE		
AGP SLOT		
Title		Rev
81865GME-775-RH		2.0
Size	Document Number	
Custom		
Date:	Monday, December 18, 2006	Sheet 13 of 30

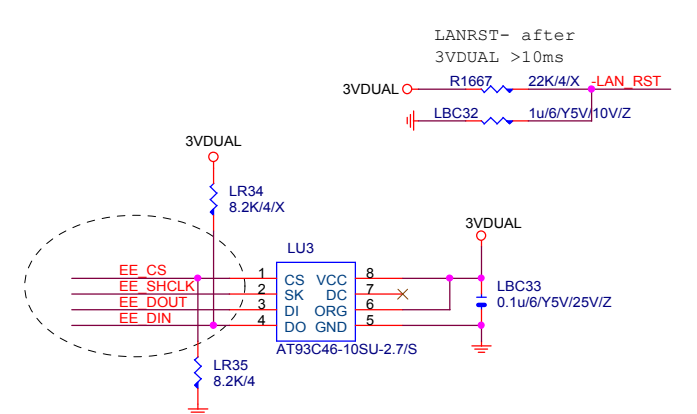
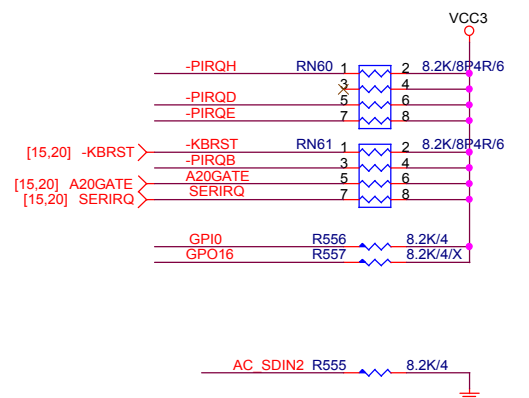
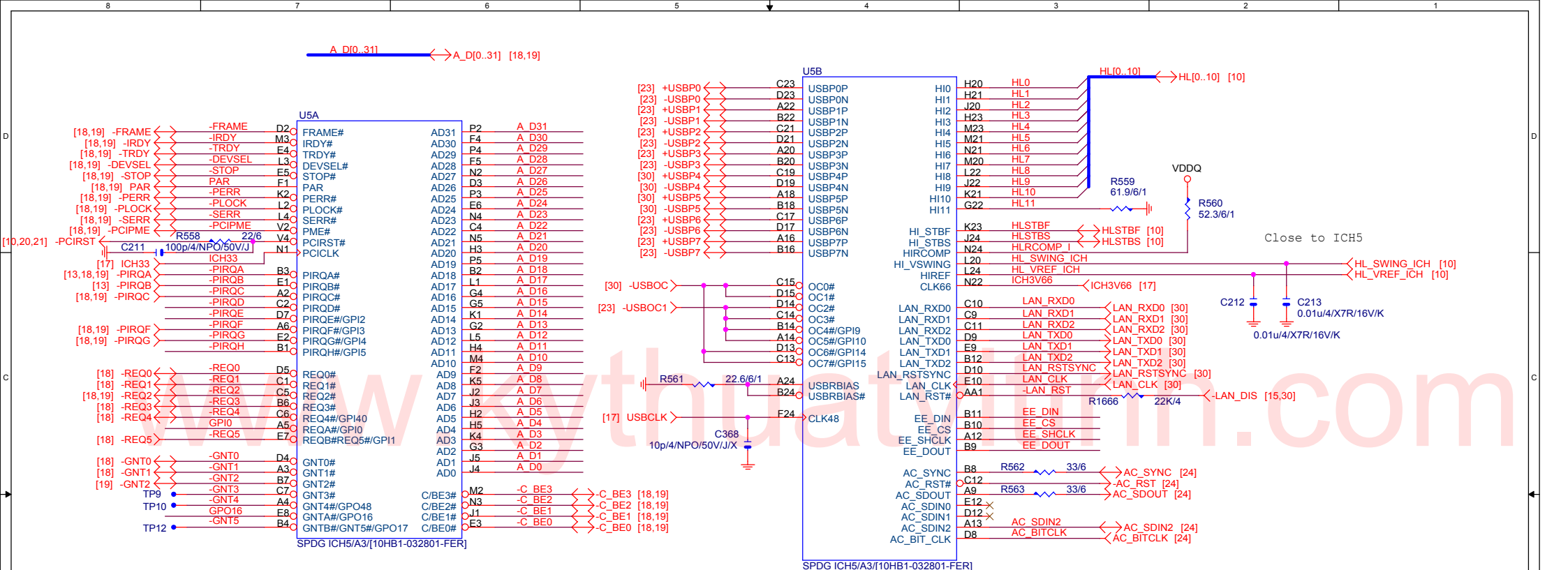

GIGABYTE			
Title			
ICH5 PCI, USB, HUB, LAN			
Size	Document Number	Rev	
Custom	81865GME-775-RH	2.0	
Date:		Sheet	14 of 30

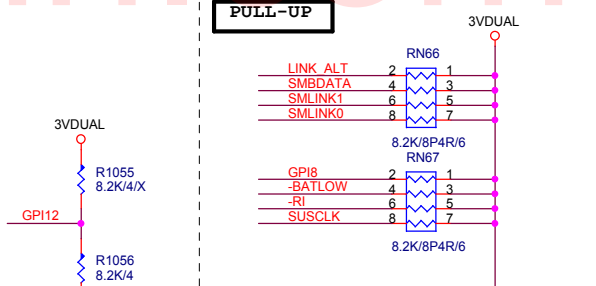
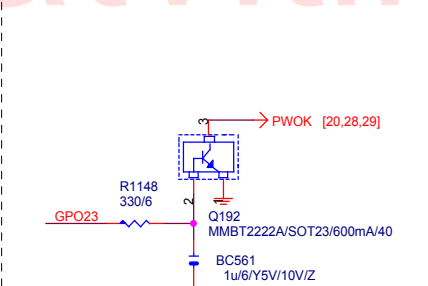
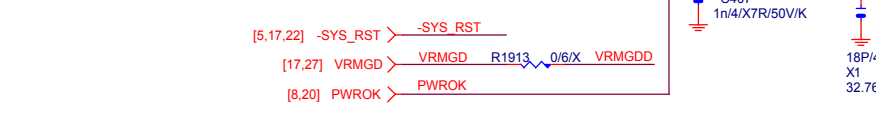
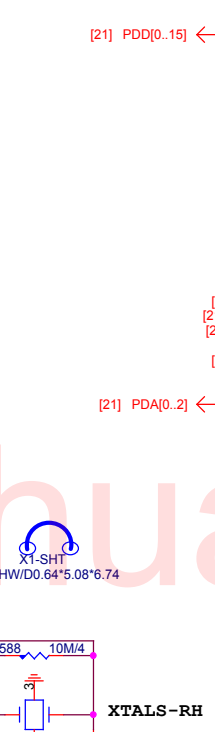
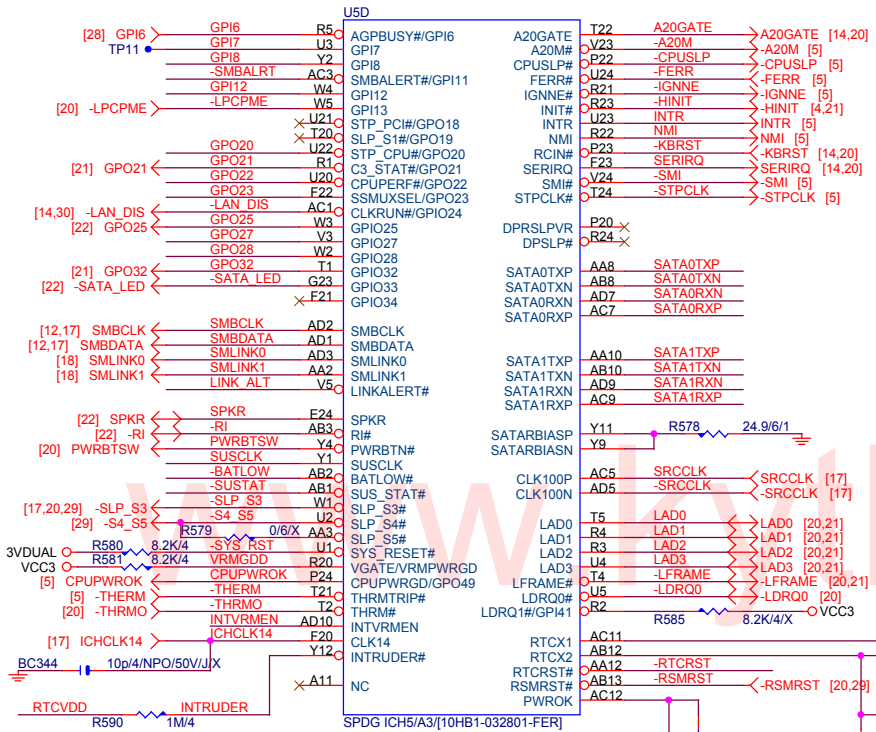

BATTERY

NEW TYPE: BATTERY-DUAL-4
 RB 不可放在 BATTERY SOCKET 下方

CLR_CMOS :	
SHORT	CLEAR CMOS
OPEN	NORMAL

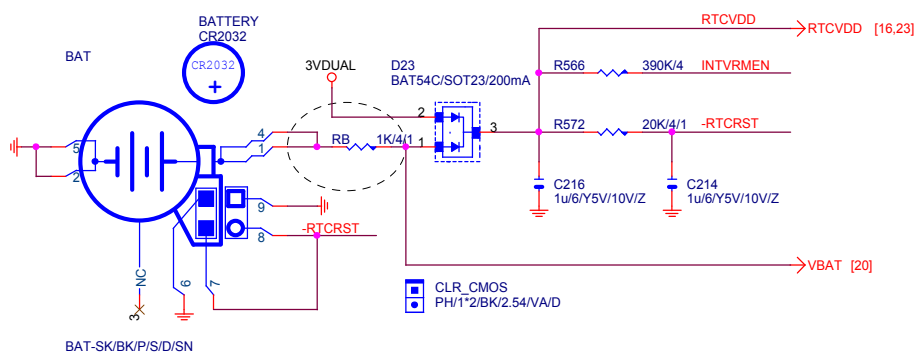

SATA1

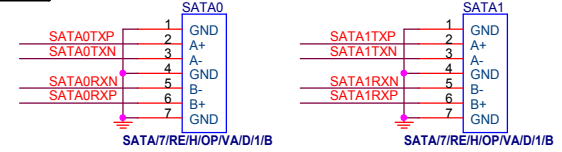

GIGABYTE

Title: ICH5 IDE, GPIO, SATA, CTRL

Size: Custom Document Number: 81865GME-775-RH Rev: 2.0

Date: Sheet 15 of 30

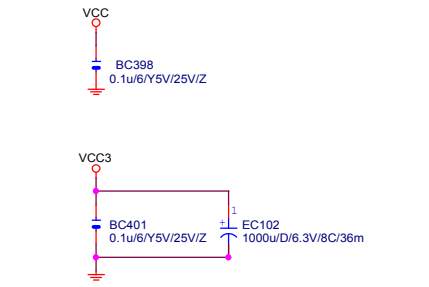
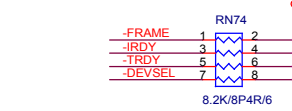
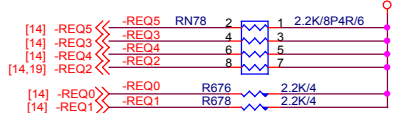
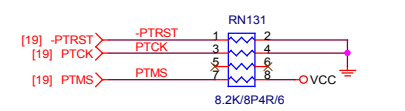
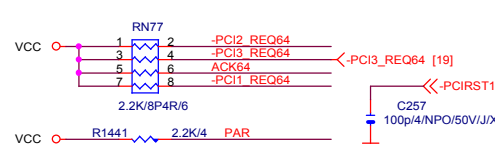
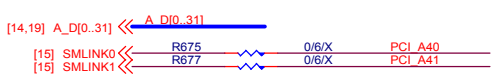
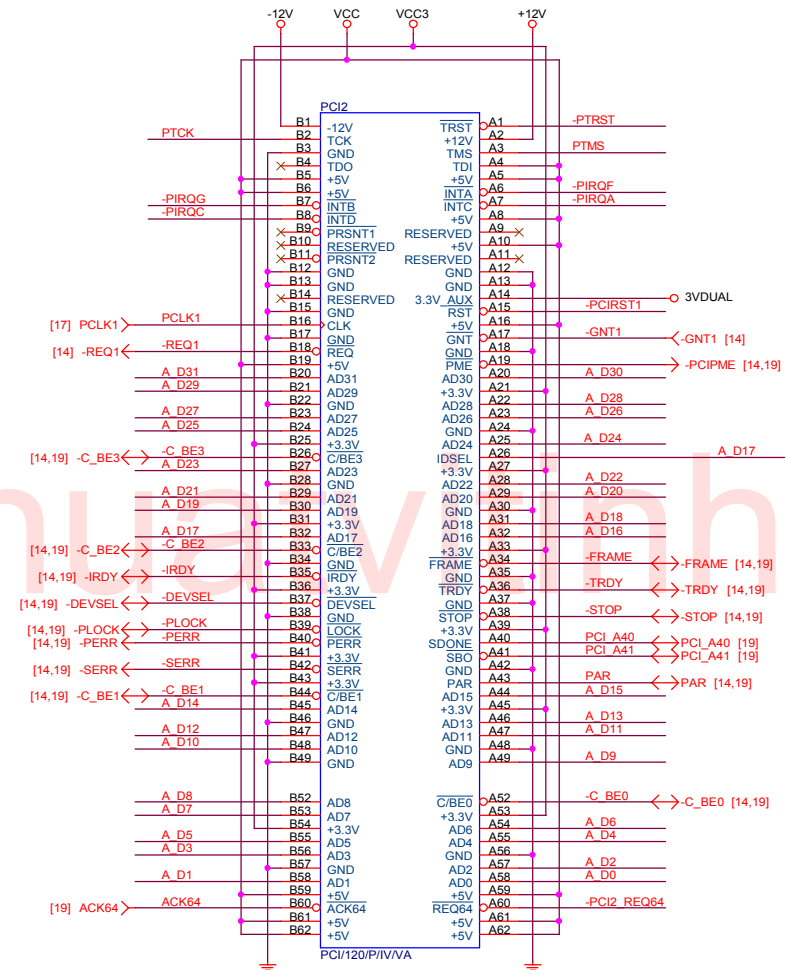
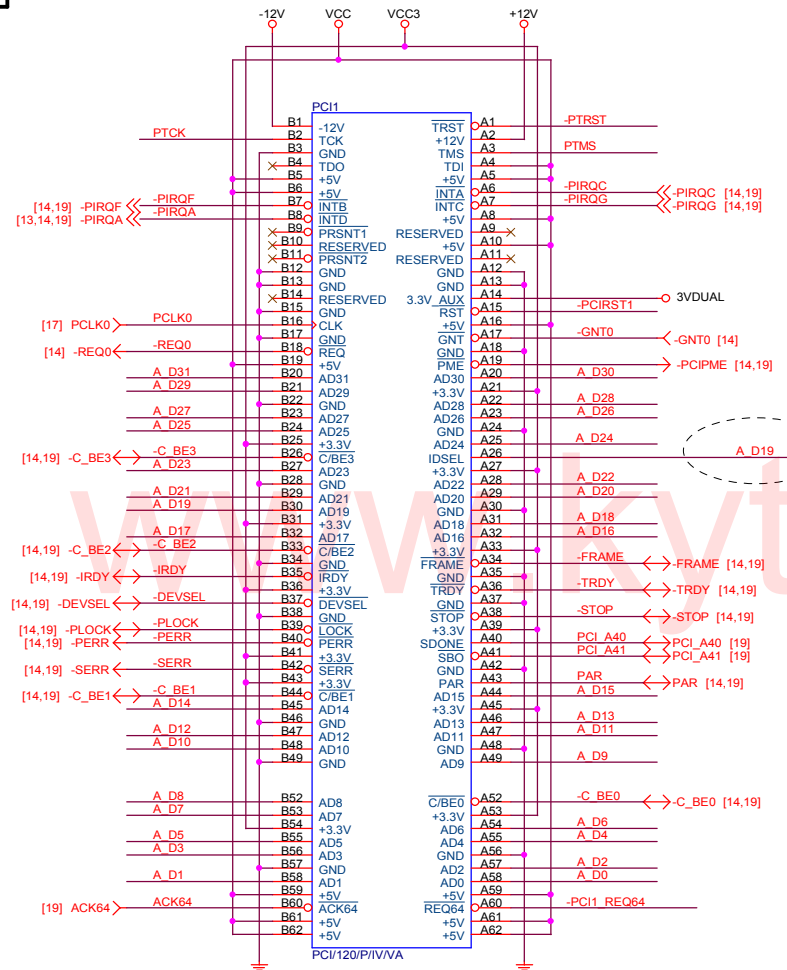

GIGABYTE

Title: PCI SLOT 1/2

Size: Custom Document Number: 81865GME-775-RH Rev: 2.0

Date: Monday, December 18, 2006 Sheet: 18 of 30

PCI3

[14,18] A_D[0..31] << A D[0..31]

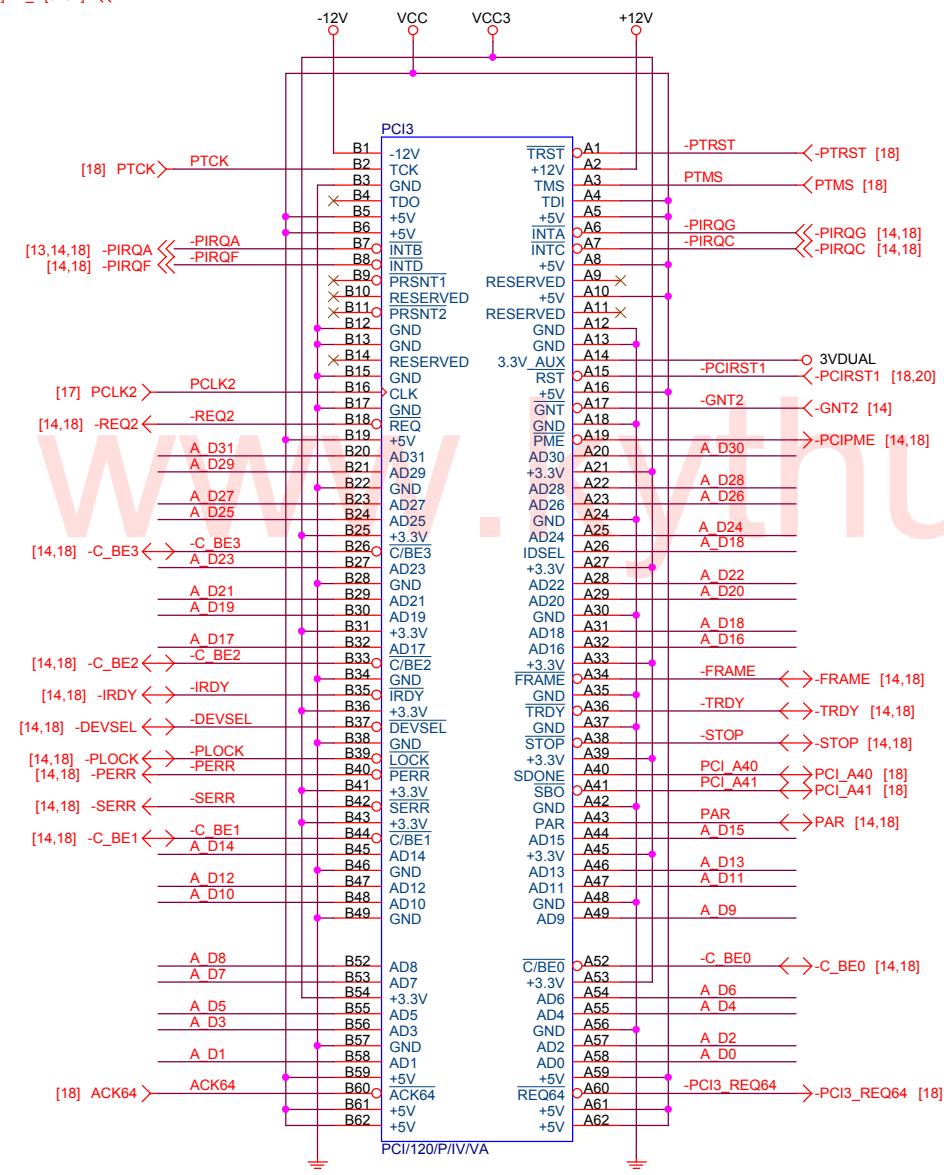

AD_18/-REQ2, -GNT2/-PIRQG, A, C, F

GIGABYTE		
Title		
PCI SLOT 3		
Size	Document Number	Rev
Custom	81865GME-775-RH	2.0
Date:	Monday, December 18, 2006	Sheet 19 of 30

www.thuatvithinh.com

COMA

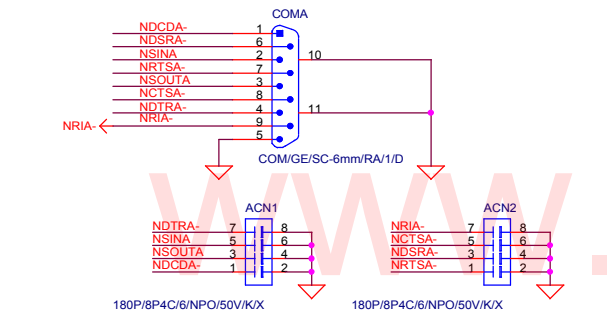
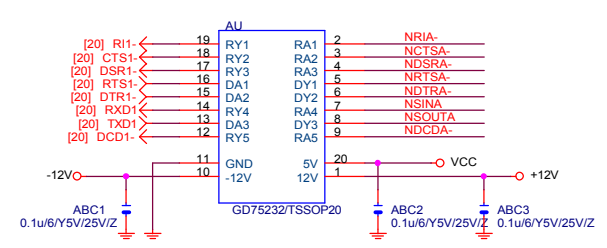

FLOPPY

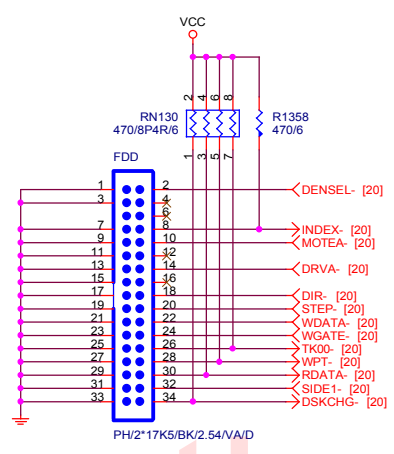

RI

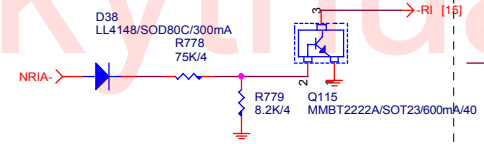

INTEL FRONT PANEL

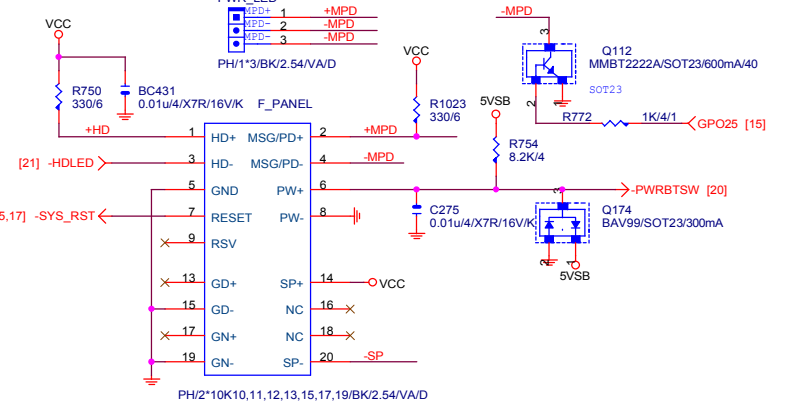

SPKR

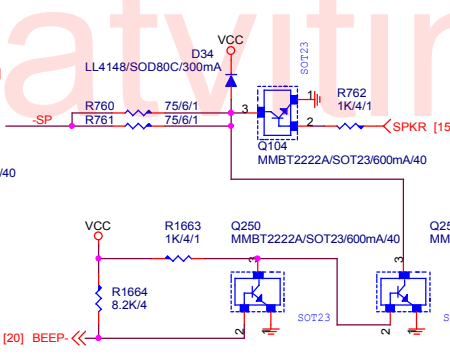

LED-

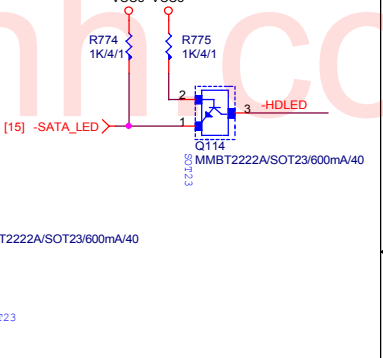

PRT PORT

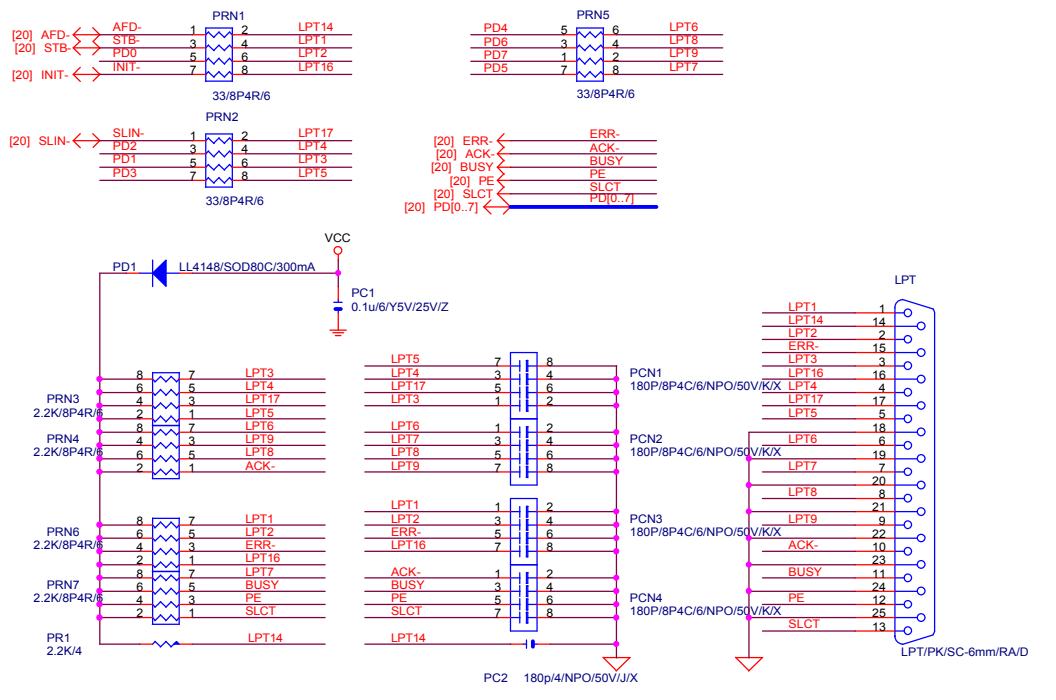

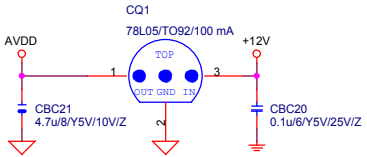
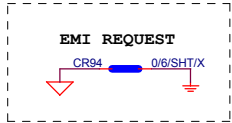
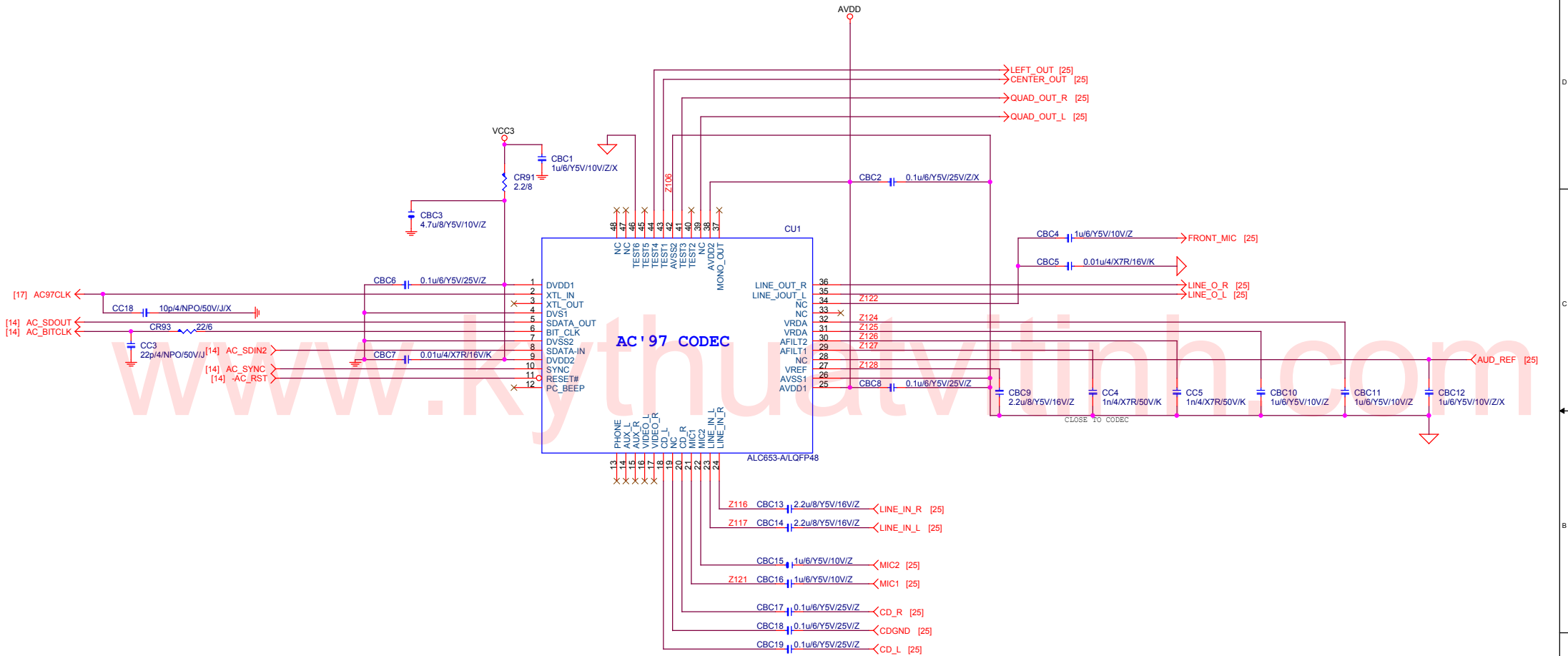

GIGABYTE		
AUDIO (ALC653)		
Title		
Size Custom	Document Number	Rev
	81865GME-775-RH	2.0
Date:	Monday, December 18, 2006	Sheet 24 of 30

INTEL FRONT AUDIO

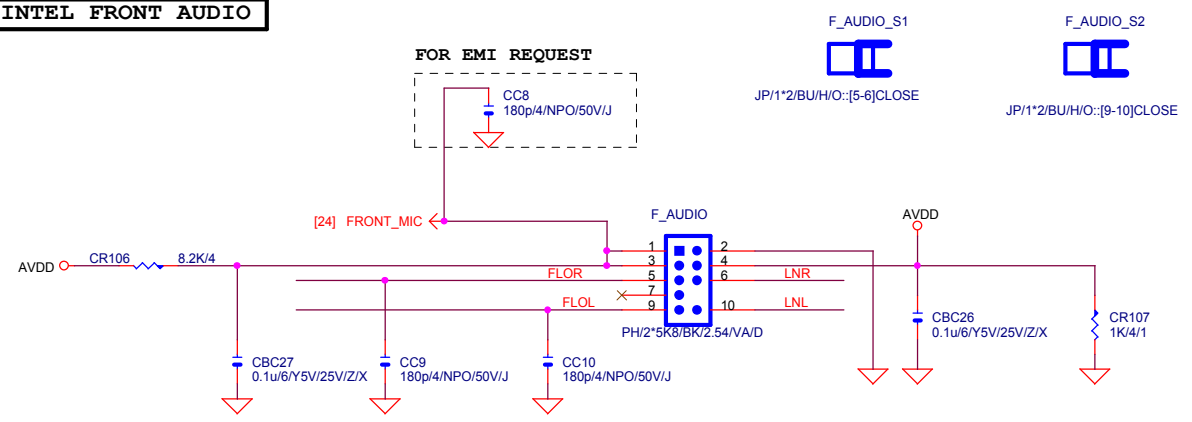

LINE-IN

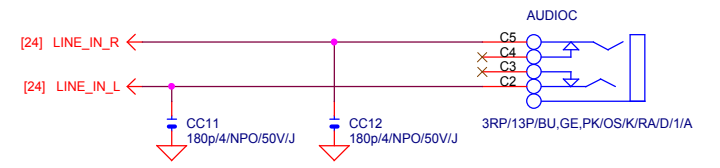

CD IN

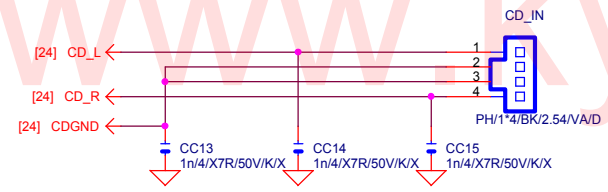

MIC

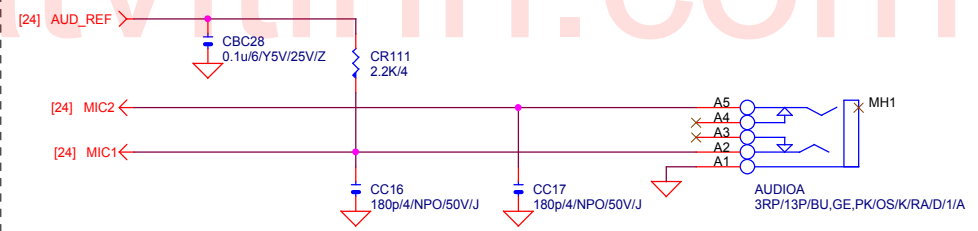

SUR_CEN

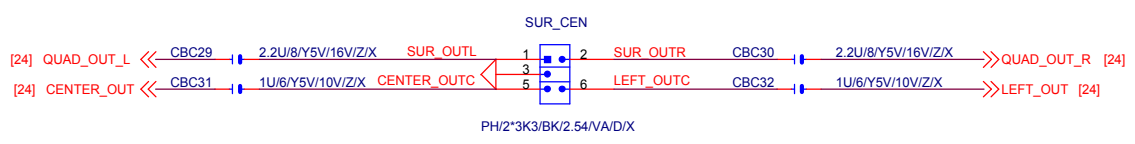

LINE OUT

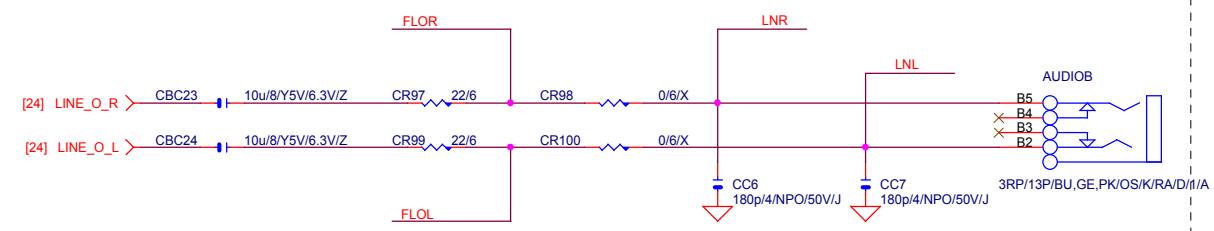

GIGABYTE			
AUDIO OUTPUT			
Size Custom	Document Number	81865GME-775-RH	
Date:	Monday, December 18, 2006	Sheet	25 of 30
			Rev 2.0

PROCESSOR HOT

asserted at 130 degree (RS2=720 ohm)
deasserted at 115 degree (RS2=1270 ohm)

VTT_PWRGD

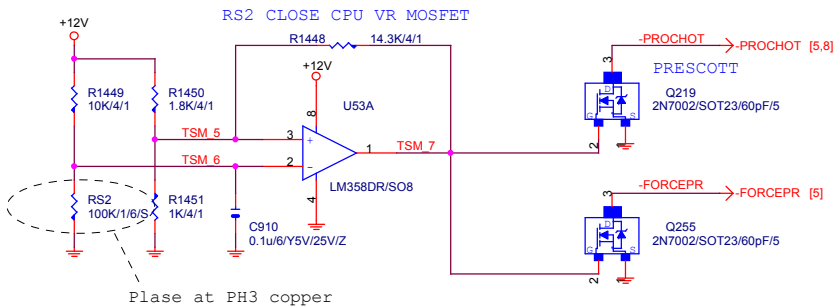

Plase at PH3 copper

ThermalTake FAN Power Consumption: 0.82A

Intel FAN Power Consumption Spec: 1.1A

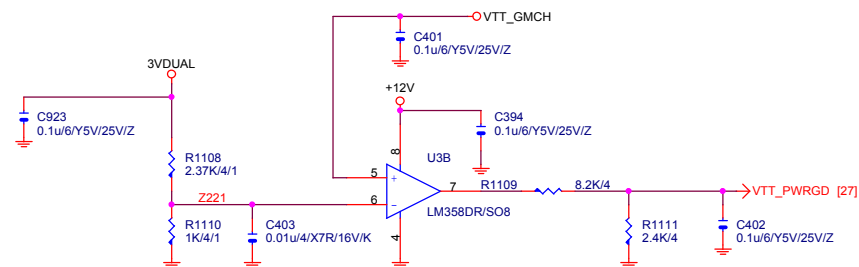

CPU_FAN

SYS_FAN

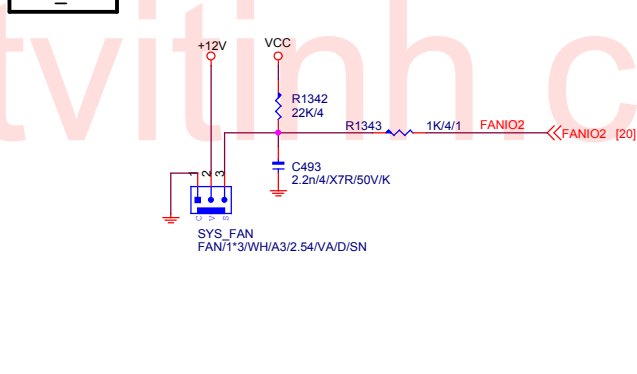
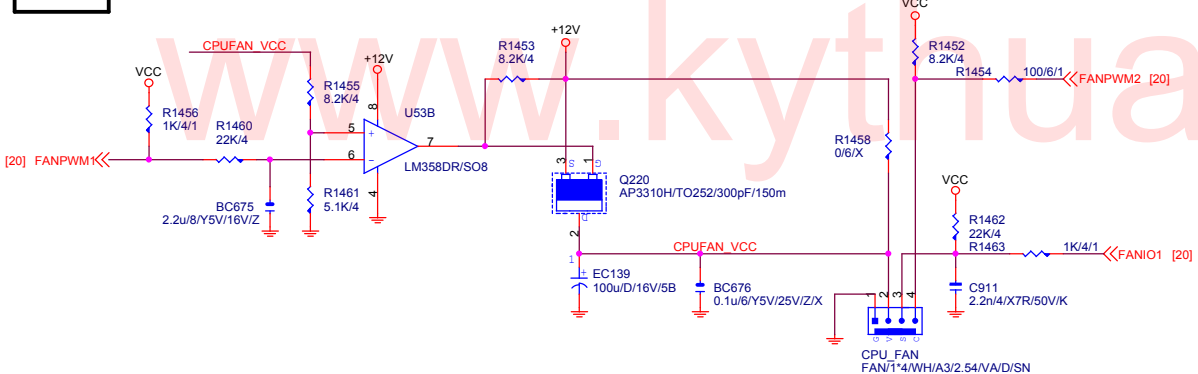

VDDQ (1.6V)

updated 方型choke:CHOKE08U-15A_1P-1

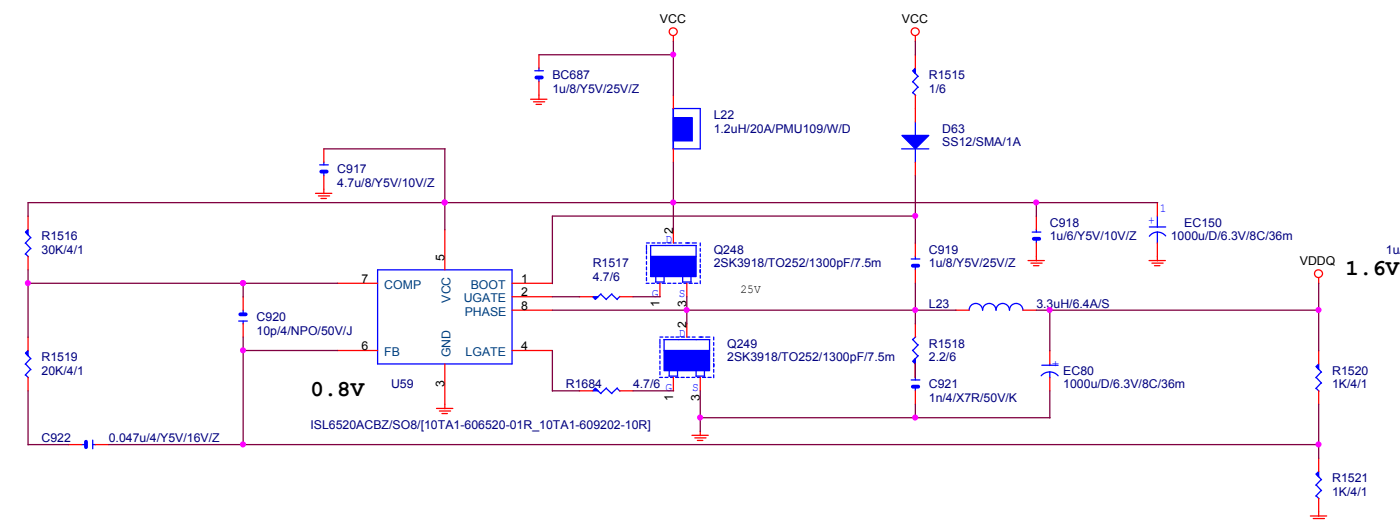

VTT_GMCH

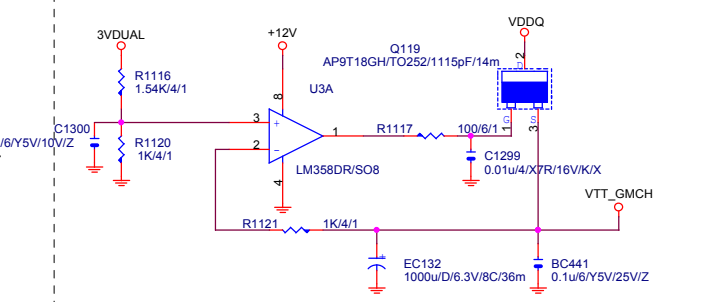

Title		
POWER,CPU_FAN,PROCHOT		
Size	Document Number	Rev
	8I865GME-775-RH	2.0
Date:	Monday, December 18, 2006	Sheet 26 of 30

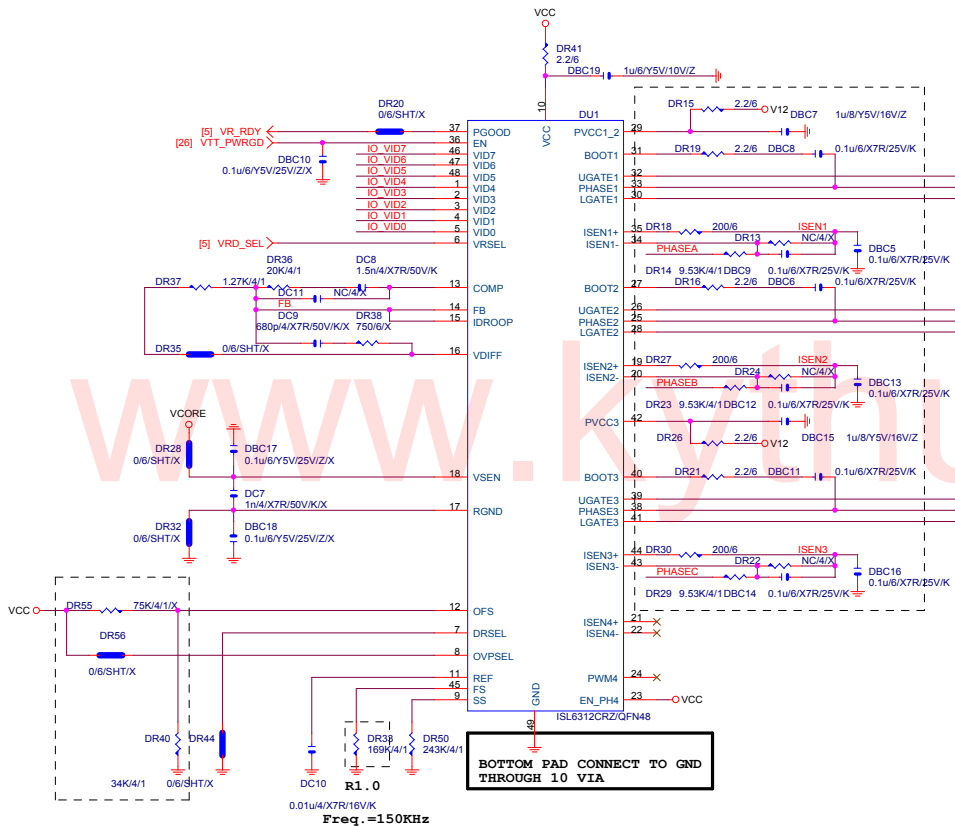

BOTTOM PAD CONNECT TO GND THROUGH 10 VIA

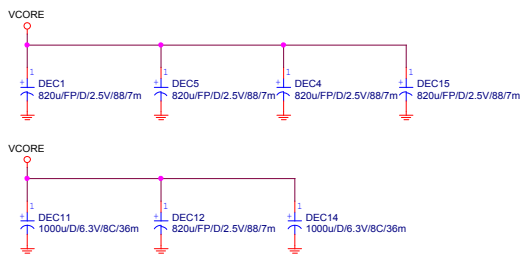
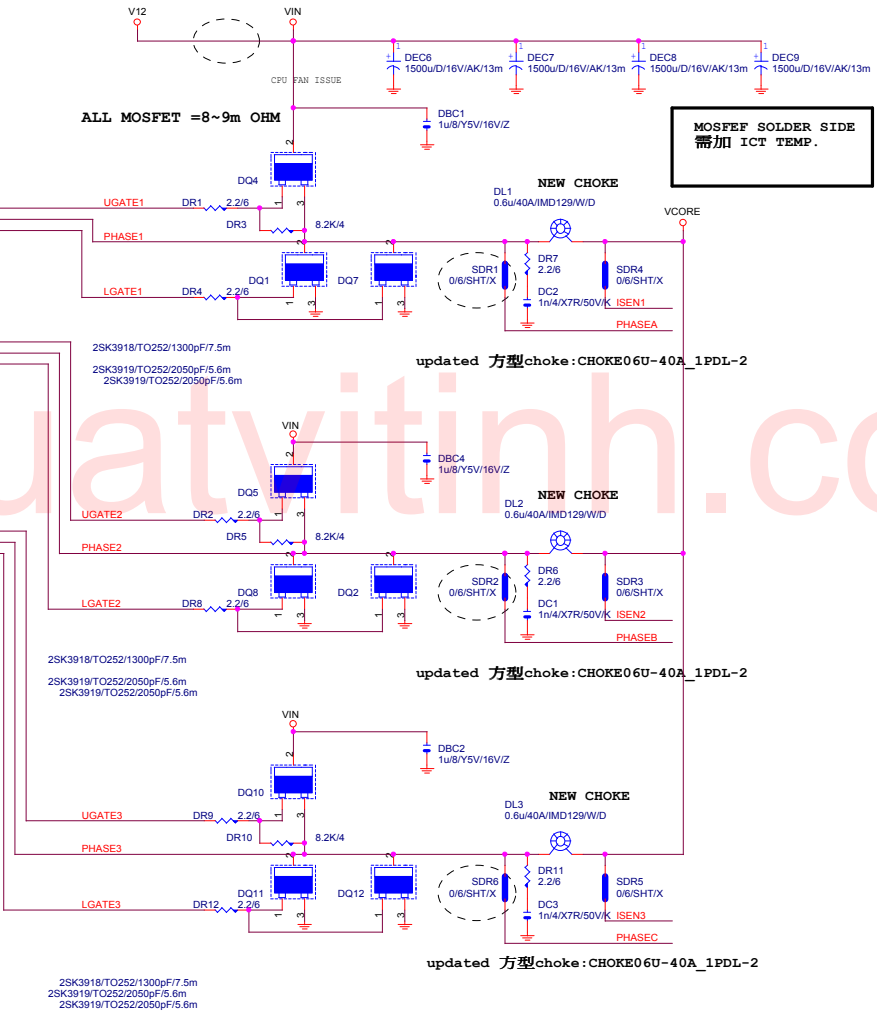
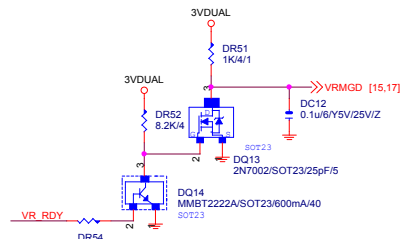
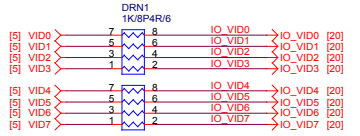
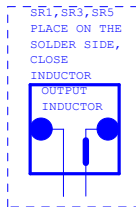

ATX POWER CONNECTOR

ATX+12V

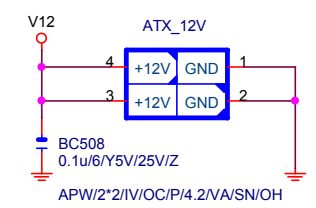
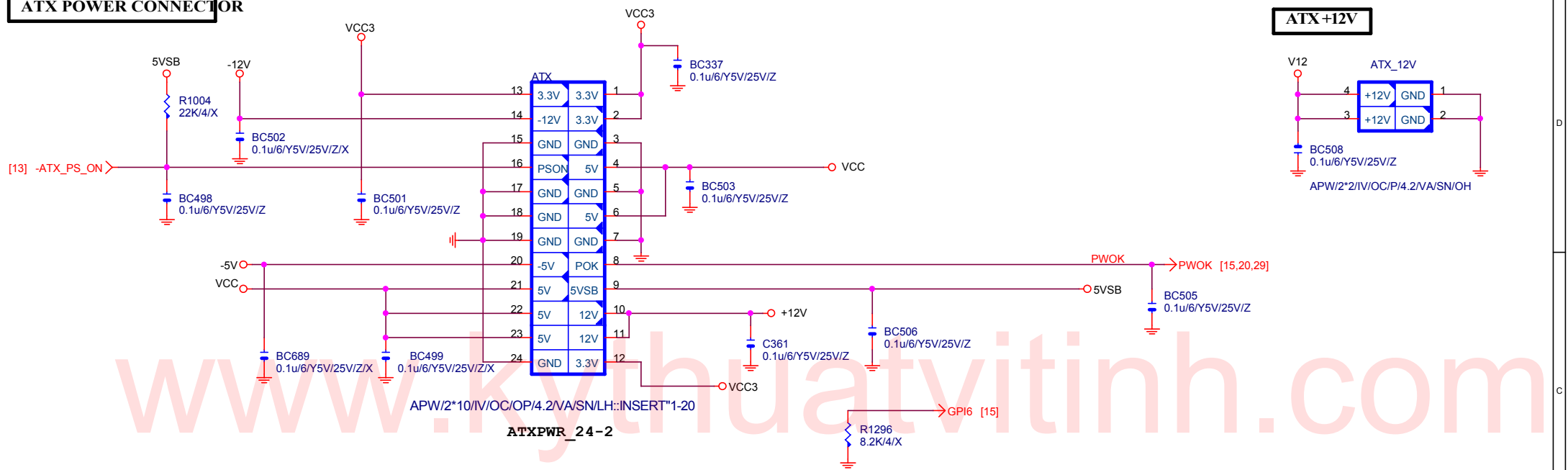

APW/2*10/IV/OC/OP/4.2VA/SN/LH::INSERT*1-20
ATXPWR_24-2

HOLE_3-RH-2

HOLE_3-RH-5MM

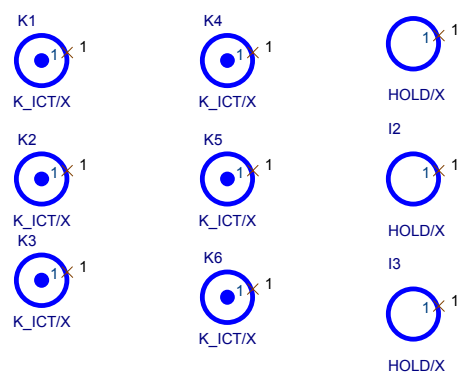
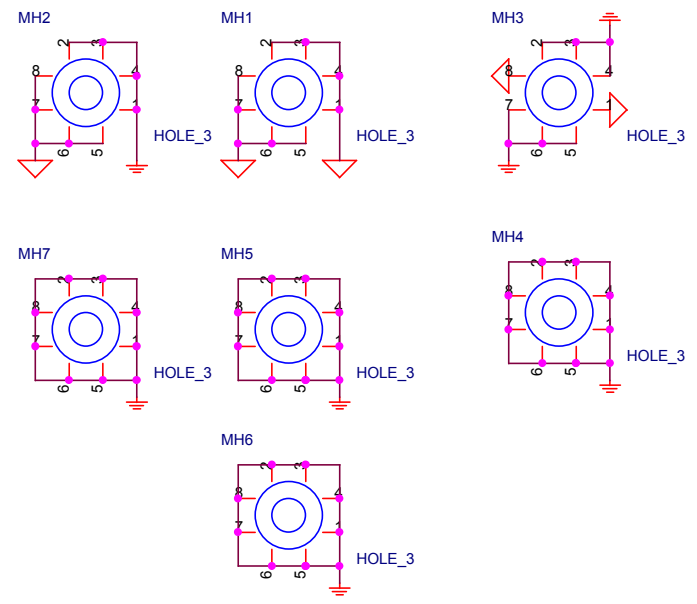

GIGABYTE	
Title	
Misc. PWR & ATX CONN.	
Size Custom	Document Number 81865GME-775-RH
Date:	Rev 2.0
Sheet 28	of 30

3VDUAL

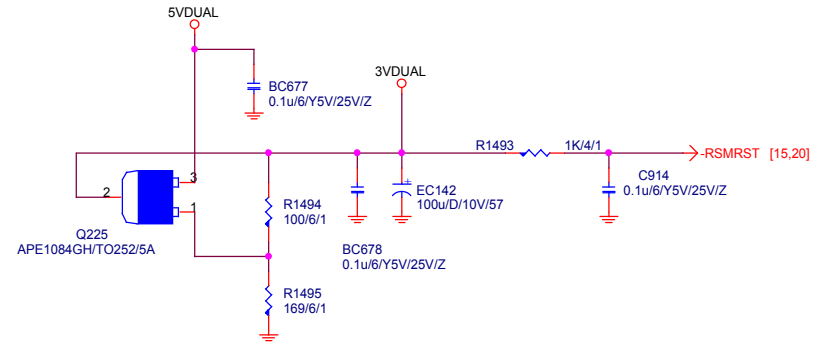

DDR25V

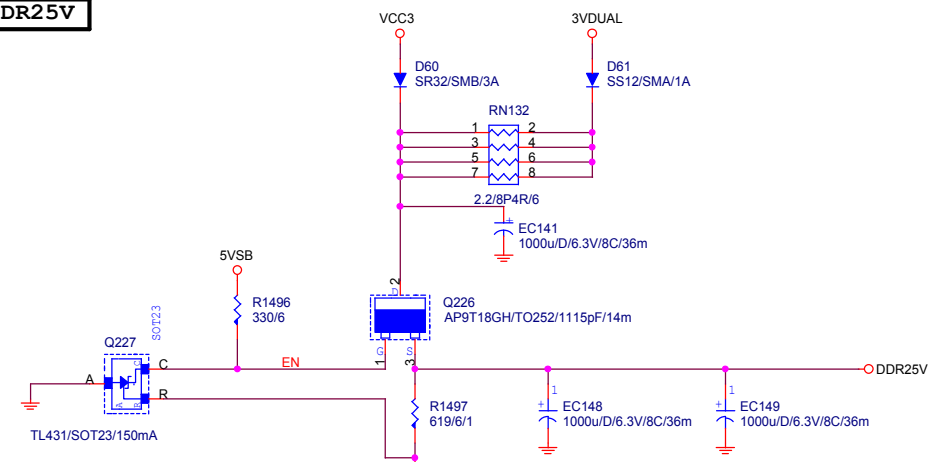

2.6V-->387
 2.65V-->587
 2.7V-->790

5VDUAL

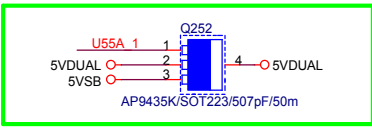
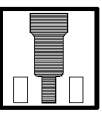
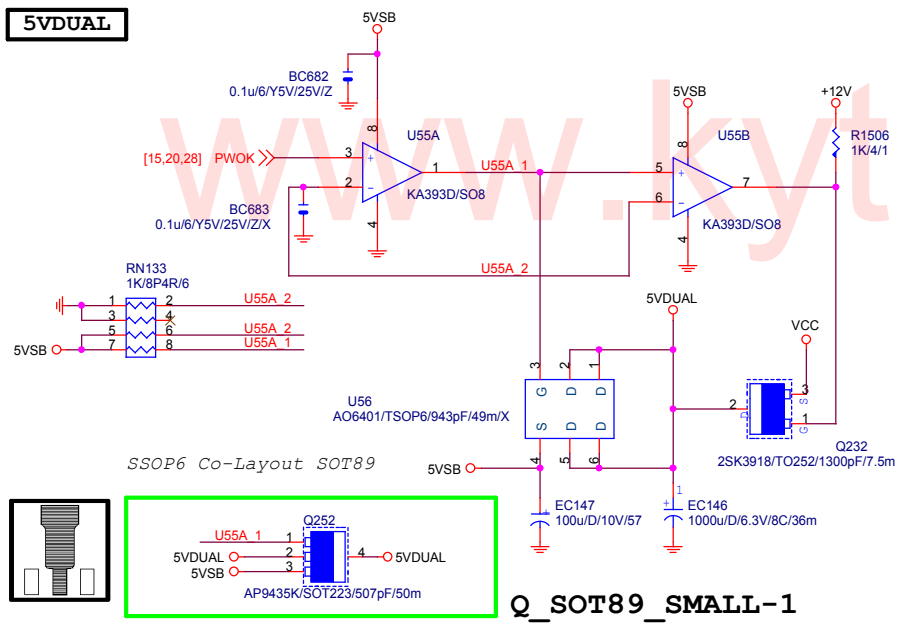

Q_SOT89_SMALL-1

3VDUAL_SB

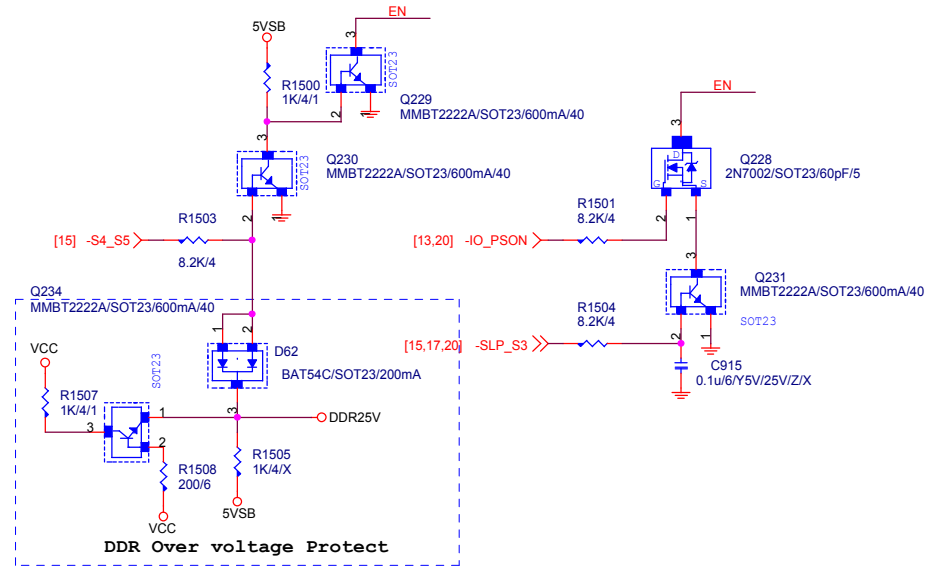
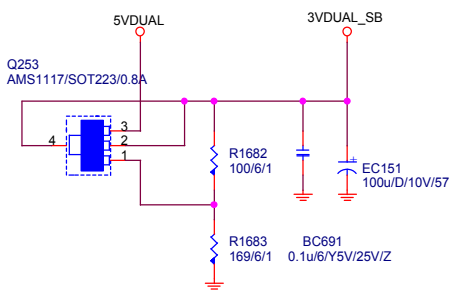

GIGABYTE			
Title	DDR POWER		
Size	Document Number	8I865GME-775-RH	Rev
Custom			2.0
Date:	Monday, December 18, 2006	Sheet	29 of 30

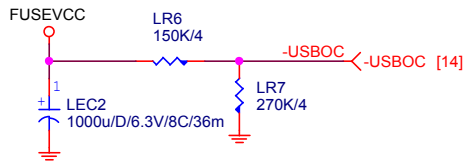
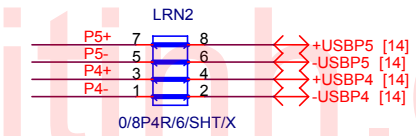
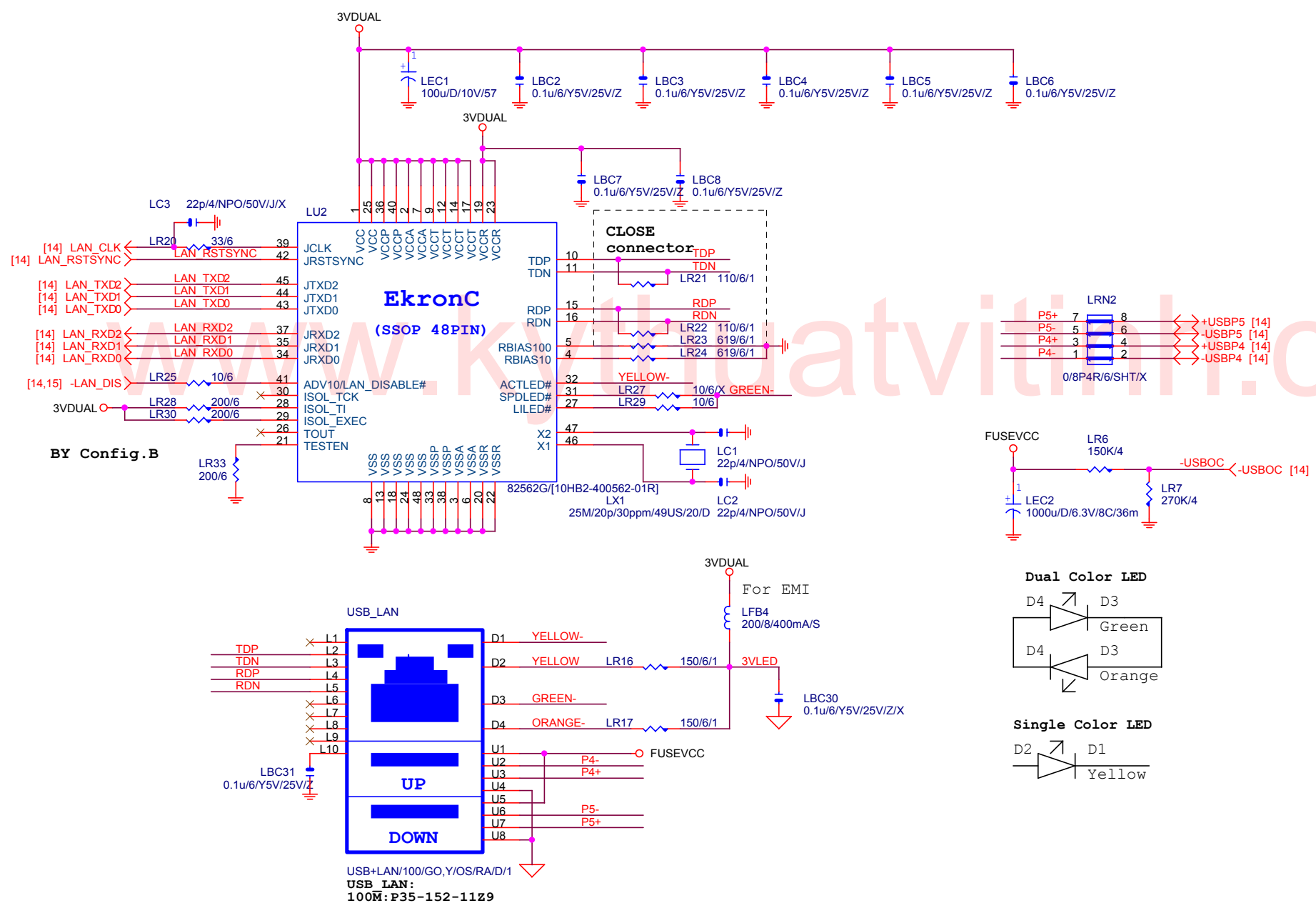

Dual Color LED

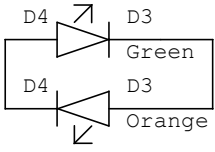

Single Color LED

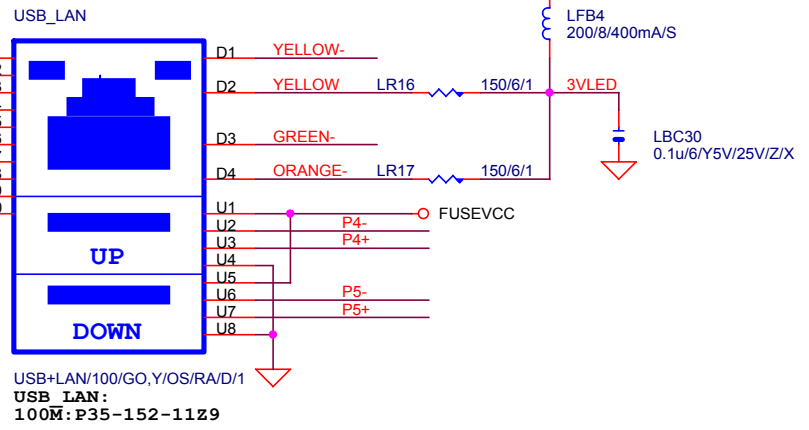
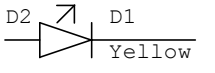

GIGABYTE

Title		
INTEL 82562G		
Size Custom	Document Number	Rev
	8I865GME-775-RH	2.0
Date:	Monday, December 18, 2006	Sheet 30 of 30