

www.laptop-schematics.com

PDF PAGE	CSA PAGE	CONTENTS	SYNC MASTER	DATE
2	2	H6P JTAG, USB, PLL, HSIC, XTAL	N/A	N/A
3	3	H6P DIGITAL I/O, BOOTSTRAPPING	N/A	N/A
4	4	H6P VDDCA, VDD1/2, VDD, VDD_CPU, VDD_GPU	N/A	N/A
5	5	H6P GND, VDDIO18, VDDIOD, VDD_SRAM, VDD_SOC	N/A	N/A
6	6	H6P NAND, NAND 12X17	N/A	N/A
7	7	H6P HIGH SPEED DIG (CAM, LCM, DP)	N/A	N/A
8	8	BUTTON FLEX B2B	N/A	N/A
9	9	L67 AUDIO CODEC (1/2)	N/A	N/A
10	10	L67 AUDIO CODEC (2/2)	N/A	N/A
11	11	FRONT CAM FLEX B2B	N/A	N/A
12	12	AMBER PMU(1/2)	N/A	N/A
13	13	AMBER PMU(2/2)	N/A	N/A
14	14	CHESTNUT, BACKLIGHT DRIVER, MESA BOOST	N/A	N/A
15	15	SPKR AMP + STROBE DRIVER	N/A	N/A
16	16	TRISTAR, EEPROM	N/A	N/A
17	17	DOCKFLEX B2B	N/A	N/A
18	18	D403 (TOUCH B2B, DRIVER ICS)	N/A	N/A
19	19	LCM B2B	N/A	N/A
20	20	OSCAR + SENSORS	N/A	N/A
21	21	REAR CAM B2B	N/A	N/A
22	22	BATT B2B, TPS, PD FEATURES	N/A	N/A
23	23	VOLTAGE PROPERTIES		
24	24	RADIO_MLB HIERARCH. SYMBOL	N/A	N/A
25	25	Cross Reference Page		
26	26	Cross Reference Page		
27	27	Cross Reference Page		

SCH 051-9681
BRD 820-3382
MCO 056-5179
BOM 639-4159 (16GB) X152
BOM 639-4160 (32GB) X152
BOM 639-3973 (64GB) X152

COMPASS BOM OPTIONS

PART#	QTY	DESCRIPTION	REFERENCE DESIGNATOR(S)	CRITICAL	BOM OPTION
639-4269	1	COMPASS INTERPOSER X152/X145	U16	Y	COMPASS_INTERPOSER

HORIZONTAL AND OTHER CAP BOM OPTIONS

PART#	QTY	DESCRIPTION	REFERENCE DESIGNATOR(S)	CRITICAL	BOM OPTION
138S0801	5	HRZNTL CAPS_1: 10UF, 0402, 6.3V	C422, C399, C405, C417, C418	Y	HRZNTL_CAP_GRP1
138S0801	5	HRZNTL CAPS_2: 10UF, 0402, 6.3V	C250, C251, C325, C357, C358	Y	HRZNTL_CAP_GRP2
138S0801	5	HRZNTL CAPS_3: 10UF, 0402, 6.3V	C260, C263, C267, C270, C261	Y	HRZNTL_CAP_GRP3
138S0801	4	HRZNTL CAPS_4: 10UF, 0402, 6.3V	C264, C268, C271, C385	Y	HRZNTL_CAP_GRP4
138S0801	4	HRZNTL CAPS_5: 10UF, 0402, 6.3V	C398, C411, C252, C297	Y	HRZNTL_CAP_GRP5
138S0801	5	HRZNTL CAPS_6: 10UF, 0402, 6.3V	C386, C387, C333, C332, C335	Y	HRZNTL_CAP_GRP6
138S0801	3	HRZNTL CAPS_7: 10UF, 0402, 6.3V	C42_RF, C43_RF, C44_RF	Y	HRZNTL_CAP_GRP7
138S0801	1	HRZNTL CAPS_8: 10UF, 0402, 6.3V	C101_RF	Y	HRZNTL_CAP_GRP8
138S0801	1	HRZNTL CAPS_9: 10UF, 0402, 6.3V	C103_RF	Y	HRZNTL_CAP_GRP9
138S0801	4	HRZNTL CAPS_10: 10UF, 0402, 6.3V	C182, C307, C209, C187	Y	HRZNTL_CAP_GRP10
138S0794	2	HRZNTL CAPS_11: 10UF, 0402, 10V	C52, C156	Y	HRZNTL_CAP_GRP11

INDUCTOR BOM OPTIONS

PART#	QTY	DESCRIPTION	REFERENCE DESIGNATOR(S)	CRITICAL	BOM OPTION
152S1785	3	BUCKO SLAVE IND: 0.47UH, TFA-A TDK	L10, L12, L14	Y	IND_BUCKO_SLV_F47UH_TFA-A_TDK
152S1834	3	BUCKO SLAVE IND: 0.47UH, CYNTEC	L10, L12, L14	Y	IND_BUCKO_SLV_F47UH_CYNTEC
152S1839	3	BUCKO SLAVE IND: 0.47UH, TAIYO	L10, L12, L14	Y	IND_BUCKO_SLV_F47UH_TAIYO
152S1807	6	AMBER BUCKXX IND: 1UH TFA-A TDK	L9, L11, L13, L15, L16, L17	Y	IND_BUCKXX_1UH_TFA-A_TDK
152S1801	6	AMBER BUCKXX IND: 1UH CYNTEC	L9, L11, L13, L15, L16, L17	Y	IND_BUCKXX_1UH_CYNTEC
152S1840	6	AMBER BUCKXX IND: 1UH TAIYO	L9, L11, L13, L15, L16, L17	Y	IND_BUCKXX_1UH_TAIYO
152S1807	1	STROBE IND: 1UH TFA-A TDK	L5	Y	IND_STROBE_1UH_TFA-A_TDK
152S1801	1	STROBE IND: 1UH CYNTEC	L5	Y	IND_STROBE_1UH_CYNTEC
152S1840	1	STROBE IND: 1UH TAIYO	L5	Y	IND_STROBE_1UH_TAIYO
152S1809	1	BUCK5 2012 IND: 1UH TFA-A TDK	L18	Y	IND_BUCK5_1UH_TFA-A_TDK
152S1835	1	BUCK5 2012 IND: 1UH CYNTEC	L18	Y	IND_BUCK5_1UH_CYNTEC
152S1843	1	BUCK5 2012 IND: 1UH TAIYO	L18	Y	IND_BUCK5_1UH_TAIYO
152S1836	1	SPKR AMP IND: 1.2UH CYNTEC	L4	Y	IND_SPKRAMP_1P2UH_CYNTEC
152S1844	1	SPKR AMP IND: 1.2UH TAIYO	L4	Y	IND_SPKRAMP_1P2UH_TAIYO
152S1721	1	CHARGER IND: 2.2UH TAIYO	L8	Y	IND_CHGR_2P2UH_TAIYO

FOR CHESTNUT BOMTABLE - SEE PG 14
FOR RADIO BOMTABLE - SEE PG 24
FOR MISC R/L/C ALTS - SEE PG 2

I2C ADDRESS MAP

I2C0	DEVICE	BINARY	7-BIT HEX	8-BIT HEX
	AMBER PMU:	110100X	0X74	0XE8
	CS35L19B AMP:	1000000X	0X40	0X80
	LM3534 BL DRIVER:	1100011X	0X63	0XC6
	TRISTAR:	0011010X	0X1A	0X34
	CHESTNUT:	0100111X	0X27	0X4E
I2C1	CT814 ALS:	0101001X	0X29	0X52
RCAM I2C	OPTEL STROBE DRIVER:	1100011X	0X63	0XC6
	REAR FACING CAM:	0010000X	0X10	0X20
	ADI VCM AF DRIVER:	0001110X	0X0E	0X1C
	ROHM VCM AF DRIVER:	0001100X	0X0C	0X18
FCAM I2C	FRONT FACING CAM:	0110110X	0X36	0X6C

NOTE: ACCEL, GYRO, COMPASS ALL USING SPI (VIA OSCAR) FOR AP COMMUNICATION.

X152 BOM CALLOUTS

PART#	QTY	DESCRIPTION	REFERENCE DESIGNATOR(S)	CRITICAL	BOM OPTION
051-9681	1	SCH, SINGLE_BRD, X152	SCH	Y	?
820-3382	1	PCBF, SINGLE_BRD, X152	PCB	Y	?
825-6838	1	EEEE FOR 639-4159 16GB	EEEE_F7V1	Y	EEEE_16G
825-6838	1	EEEE FOR 639-4160 32GB	EEEE_F7V2	Y	EEEE_32G
825-6838	1	EEEE FOR 639-3973 64GB	EEEE_F4LR	Y	EEEE_64G
339S0206	1	H6P + 1GB SAMSUNG	U1	Y	H6P_1GB_SAMSUNG
339S0207	1	H6P + 1GB ELPIDA	U1	Y	H6P_1GB_ELPIDA
339S0208	1	H6P + 1GB HYNIX	U1	Y	H6P_1GB_HYNIX

OSCAR BOM OPTIONS

PART#	QTY	DESCRIPTION	REFERENCE DESIGNATOR(S)	CRITICAL	BOM OPTION
337S4370	1	OSCAR CSP	U9	Y	OSCAR_CSP
337S4417	1	OSCAR FCLGA	U9	Y	OSCAR_FCLGA

OPEL BOM OPTIONS

PART#	QTY	DESCRIPTION	REFERENCE DESIGNATOR(S)	CRITICAL	BOM OPTION
353S3899	1	TI OPEL	U17	Y	OPEL_TI

NAND BOM OPTIONS

PART#	QTY	DESCRIPTION	REFERENCE DESIGNATOR(S)	CRITICAL	BOM OPTION
335S0930	1	NAND, 19NM, 16GX8, MLC, PPN1.5	U4	Y	NAND_16G_HYNIX
335S0931	1	NAND, 19NM, 32GX8, MLC, PPN1.5	U4	Y	NAND_32G_HYNIX
335S0932	1	NAND, 19NM, 64GX8, MLC, PPN1.5	U4	Y	NAND_64G_HYNIX

NAND BOM ALTERNATES

PART NUMBER	ALTERNATE FOR PART NUMBER	BOM OPTION	REF DES	COMMENTS:
335S0921	335S0930	NAND_16G_TOSH	U4	?
335S0933	335S0930	NAND_16G_SAND	U4	?
335S0922	335S0931	NAND_32G_TOSH	U4	?
335S0934	335S0931	NAND_32G_SAND	U4	?
335S0923	335S0932	NAND_64G_TOSH	U4	?
335S0935	335S0932	NAND_64G_SAND	U4	?

USB GOLDENEYE BOM OPTIONS

PART#	QTY	DESCRIPTION	REFERENCE DESIGNATOR(S)	CRITICAL	BOM OPTION
155S0583	2	E75 COMMON MODE CHOKES	L20, L22	Y	CMC_E75_DIFFPAIRS
152S1737	2	USB TX 10UH SERIES INDUCTORS	R163, R164	Y	USB_TX_SERIES_IND

TRISTAR BOM OPTIONS

PART#	QTY	DESCRIPTION	REFERENCE DESIGNATOR(S)	CRITICAL	BOM OPTION
343S0614	1	CBTL1608A1UK, WSCP, TRISTAR	U2	Y	TRISTAR
343S0639	1	CBTL1610A0UK, WSCP, TRISTAR2	U2	Y	TRISTAR2
117S0202	2	RES 200HM 01005 5%, TRISTAR2	R102, R103	Y	TRISTAR2
118S0671	2	RES 150HM 01005 5%, TRISTAR	R102, R103	Y	TRISTAR

AUDIO BOM OPTION

PART#	QTY	DESCRIPTION	REFERENCE DESIGNATOR(S)	CRITICAL	BOM OPTION
155S0556	2	FERRITE 0402 P140HM 1A	FL6, FL9	Y	SPKAMP_FERRITE_REG
155S0731	2	FERRITE 0402 P060HM 1P8A	FL6, FL9	Y	SPKAMP_FERRITE_LOWDCR
116S0004	2	RESISTOR 0402 00HM 1A	FL6, FL9	Y	SPKAMP_FERRITE_00HM
132S0396	2	CAP 01005 10V 1000PF	C500, C501	Y	SPKAMP_CAPFILT_1000PF
132S0437	2	CAP 01005 10V 150PF	C500, C501	Y	SPKAMP_CAPFILT_150PF
131S0283	2	CAP 01005 10V 100PF	DZ13, DZ14	Y	SPKAMP_ESDFILT_100PF
338S1077	1	CLASSD AMP, L19	U22	Y	SPKAMP_IC_L19
338S1161	1	CLASSD AMP, L20	U22	Y	SPKAMP_IC_L20
117S0002	1	0201 00HM	R128	Y	SPKAMP_SENSE_R_L20
118S0583	1	0201 0.10HM	R128	Y	SPKAMP_SENSE_R_L19

H6P: JTAG, USB, PLL, HSIC, XTAL

MISC COMPONENTS ALTERNATES

PART NUMBER	ALTERNATE FOR PART NUMBER	BOM OPTION	REF DES	COMMENTS:
107S0146	107S0208			ALT FOR THERMISTOR
138S0702	138S0657			?
138S0697	138S0695			?
138S0746	138S0705			?
138S0739	138S0706			?
155S0773	155S0453			?
155S0667	155S0583			?
335S0895	335S0874			?
138S0703	138S0648			?

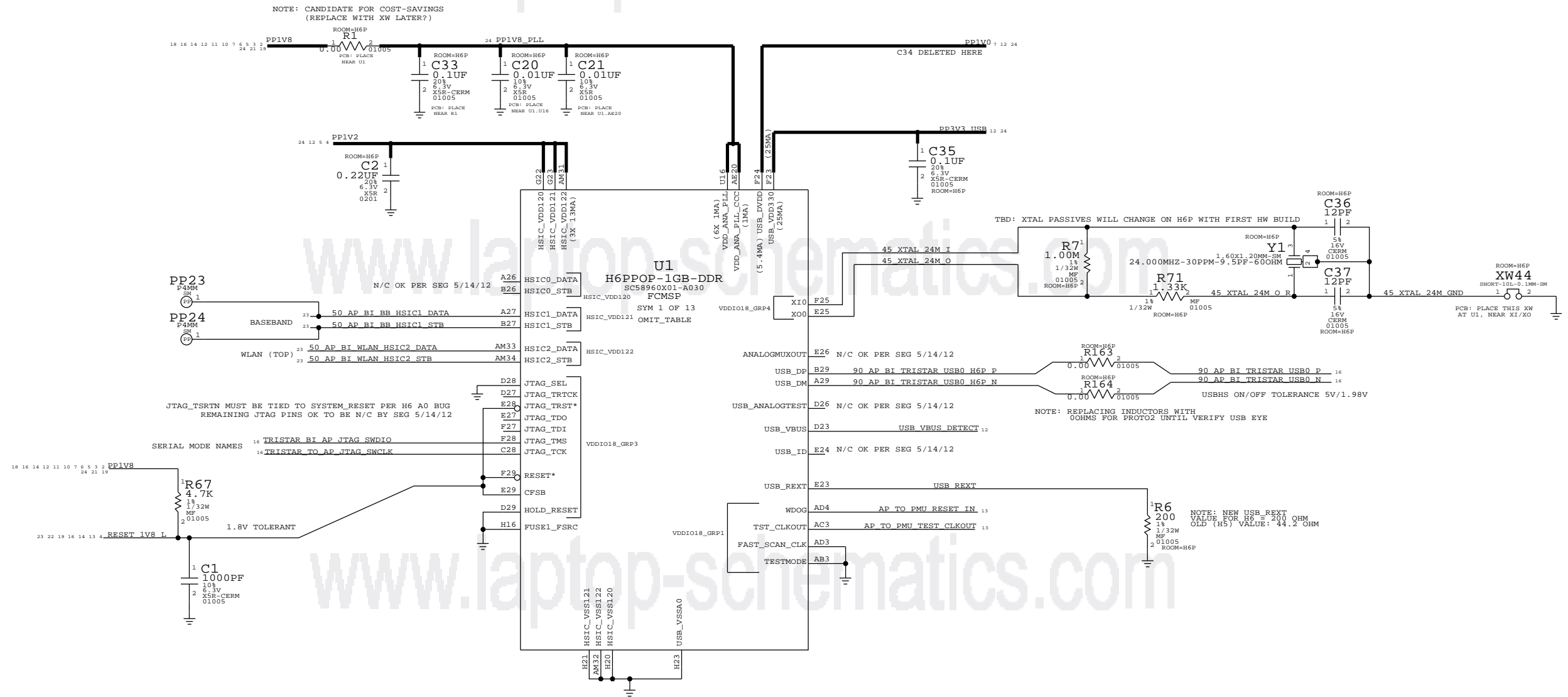

H6P: DIGITAL I/O, BOOTSTRAPPING

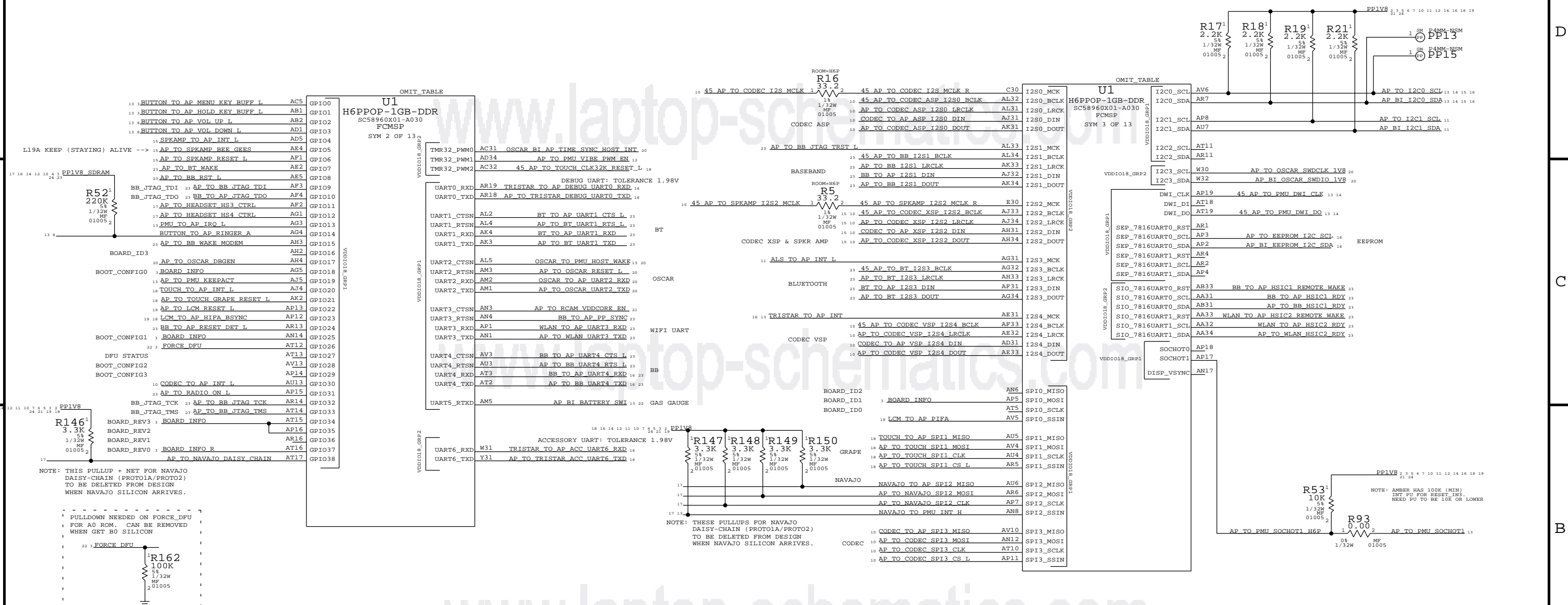

BOOTSTRAPPING (BOARD_REV, BOARD_ID, BOOT_CFG)

```

BOARD_REV[3:0]={GPIO34, GPIO35, GPIO36, GPIO37}
FLOAT=LOW, PULLUP=HIGH
1111 PROTO2/2A, TRISAR/L19
1110 PROTO2A, TRISTAR2/L20
1101 EVT1 MAIN BUILD
1100 EVT1 MESA BUILD <--- SELECTED
1100 EVT1 MESA BUILD <--- DNP R3000 TO SELECT

BOARD_ID[3:0]={GPIO16, SPI0_MISO, SPI0_MOSI, SPI0_SCLK}
FLOAT=LOW, PULLUP=HIGH
0000 X145 MLB
0001 X145 DEV
0010 X152 MLB <--- SELECTED
0011 X152 DEV

BOOT_CONFIG[3:0]={GPIO29_CONFIG3, GPIO28_CONFIG2, GPIO25_CONFIG1, GPIO18_CONFIG0}
FLOAT=LOW, PULLUP=HIGH
0000 SPI0
0001 SPI0 TEST MODE
0010 NAND
0011 NAND TEST MODE <--- SELECTED
    
```

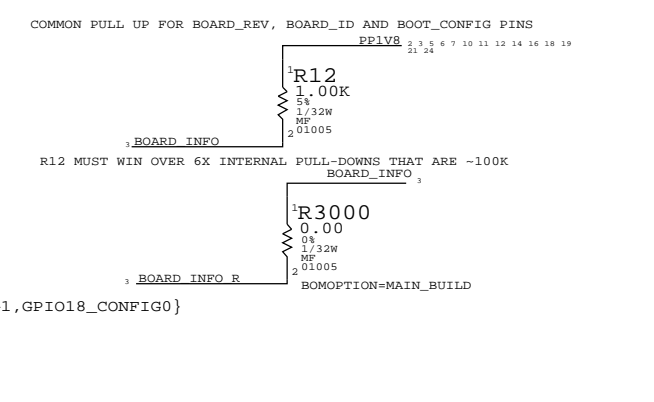

MENU & POWER / HOLD KEY BUFFER

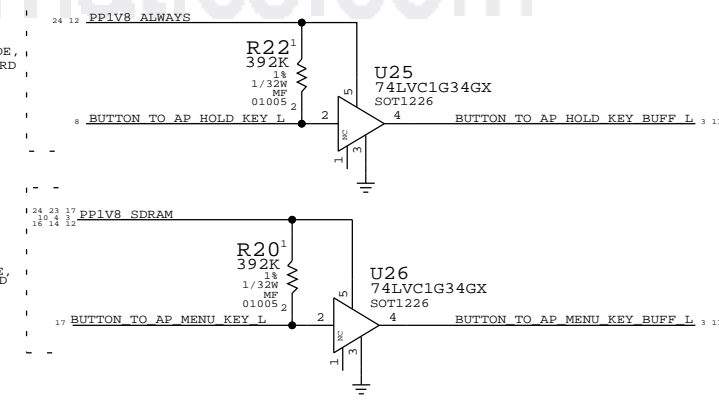

H6P (GND, VDDIO18, VDDIOD, VDD_SRAM, VDD_SOC)

VDD_SRAM, VDD_SOC

JUST A FEW GNDS

VDDIOD, VDDIO18

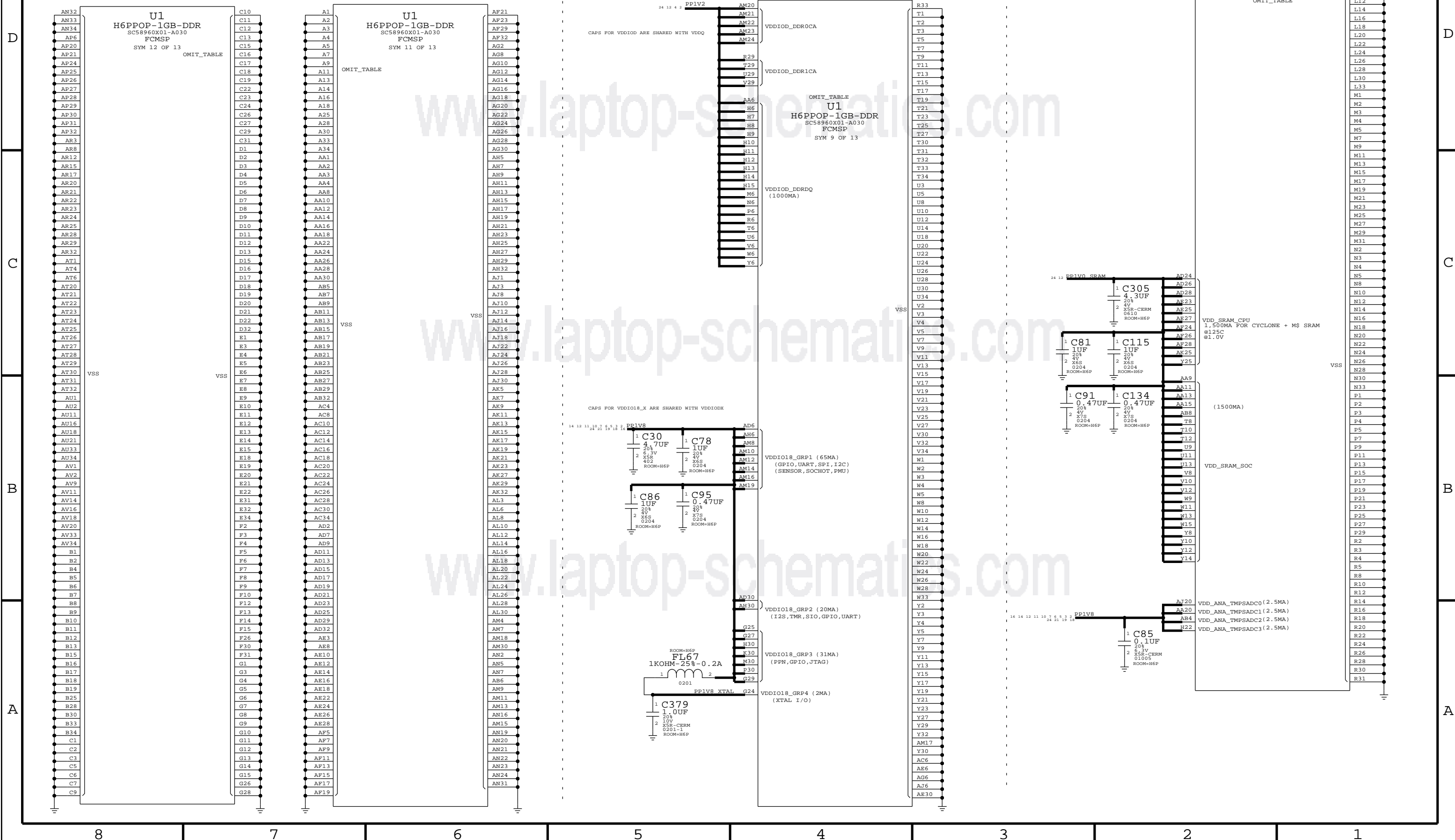

H6P NAND + 12X17 NAND PKG

SUPPORT FOR PPN1.5 (1.8V IO) ONLY

PCB: THIS XW ON OUTER LAYER, ACCESSIBLE FOR REWORK

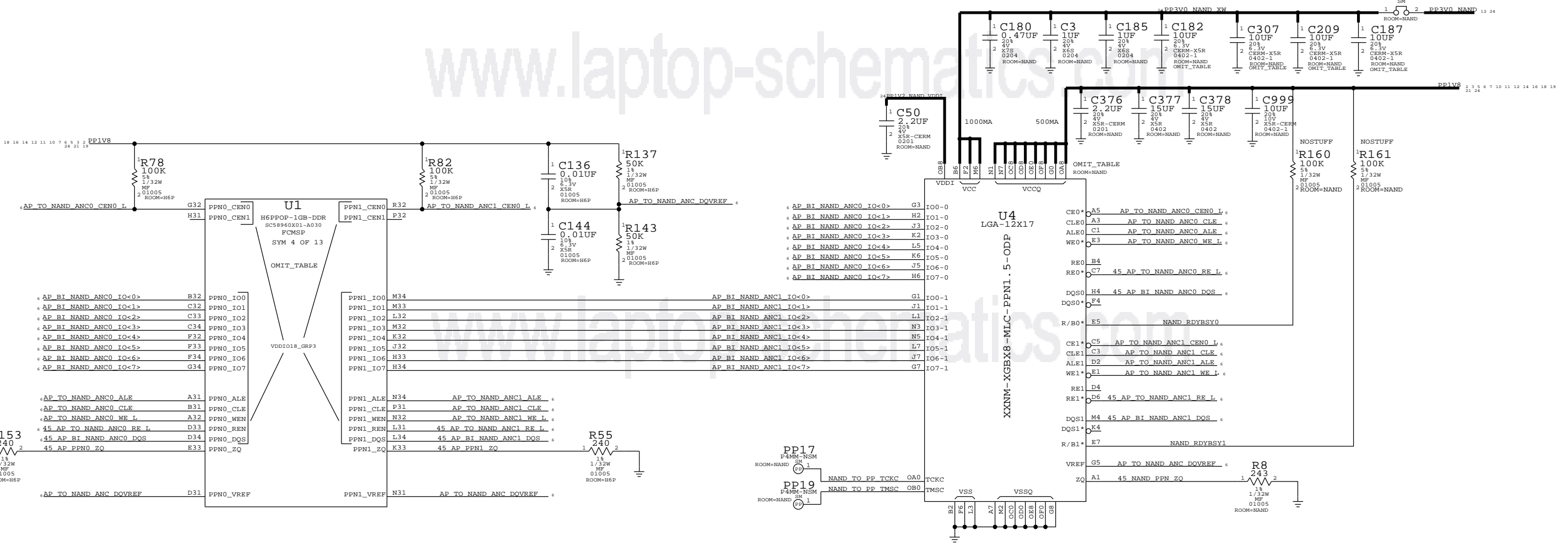

NOTE: NAND PADS SHOULD BE SHIELDED FROM TRACES WITH A GROUND PLANE

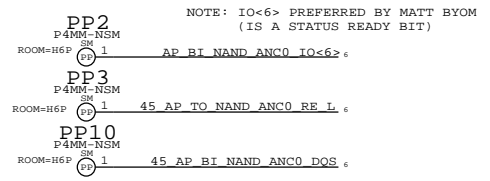

H6P HIGH SPEED DIG (CAM, LCD, DP)

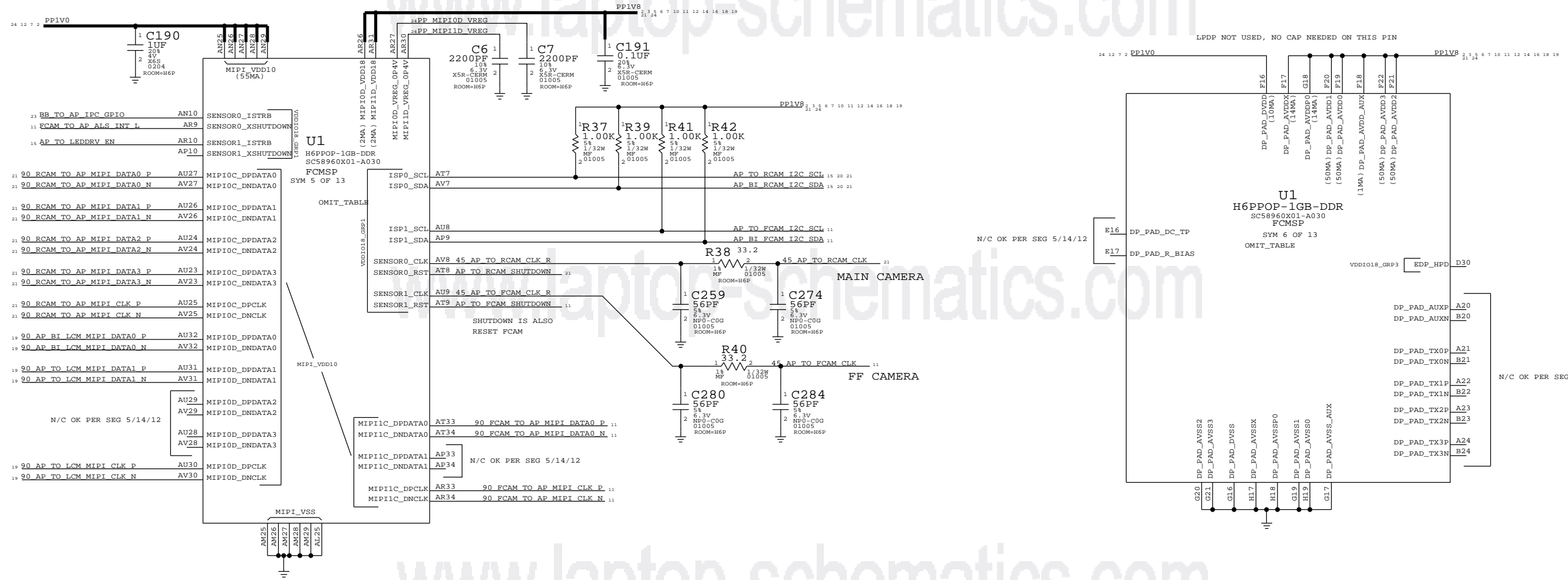

www.laptop-schematics.com

www.laptop-schematics.com

www.laptop-schematics.com

BUTTON FLEX (VIBE DRIVER, BUTTONS, ANC REF MIC, STROBE, STROBE_NTC)

STROBE:
LED WARM, RETURN

WIFI FLEX PAC:
VDD (3.0V)

VIBE DRIVE

BUTTONS:
RINGER, HOLD,
VOL_UP/DOWN

STROBE:
STROBE NTC

MIC2 (ANC REF MIC):
MIC2/3 BIAS,
MIC2_P,_N

WIFI FLEX PAC:
PAC SPI BUS

STROBE:
LED COOL

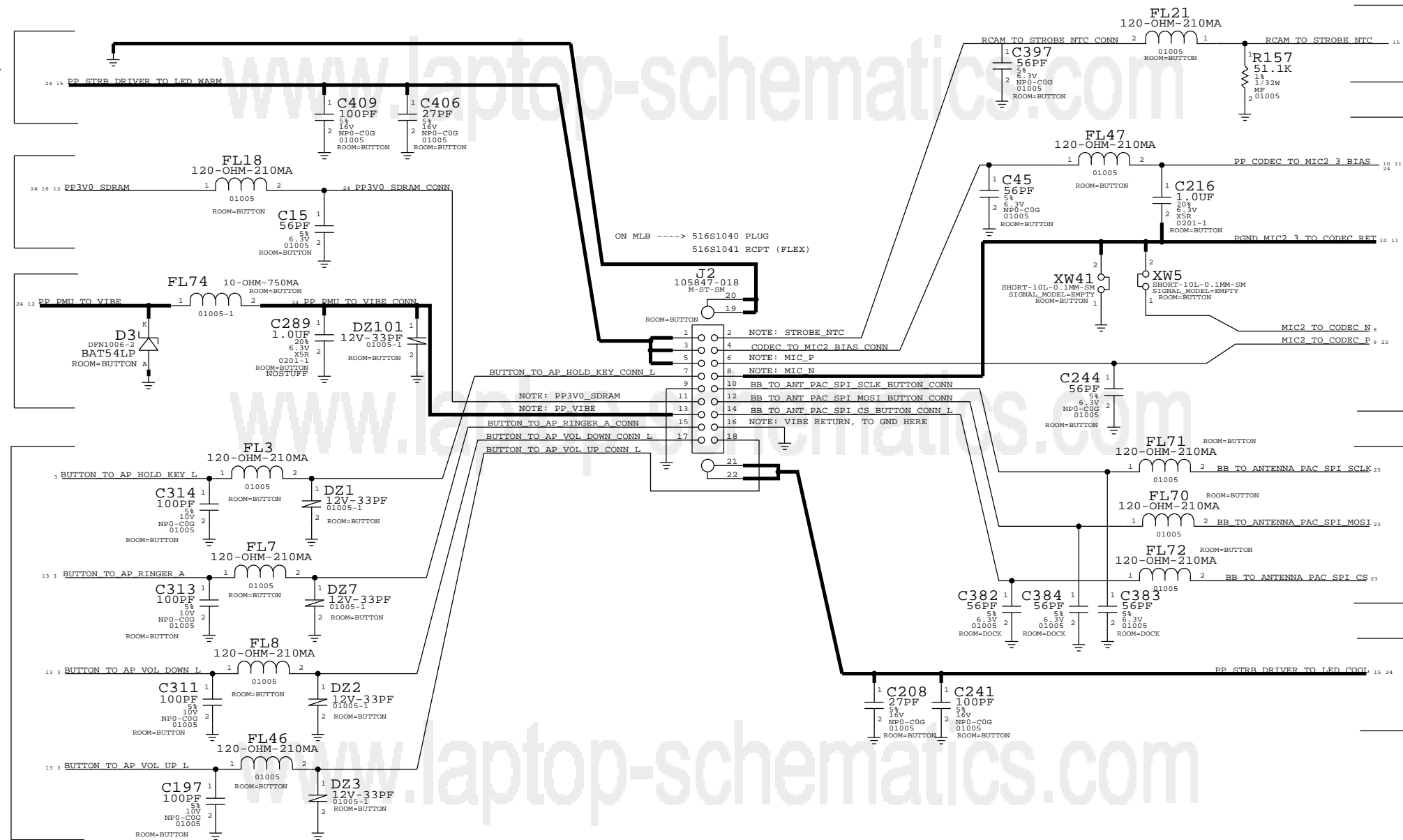

L67 AUDIO CODEC

AUDIO I/O

(ANALOG MIC IN, DIG MIC IN, HPOUT, LINEOUT, RECEIVER OUT, MIKEYBUS)

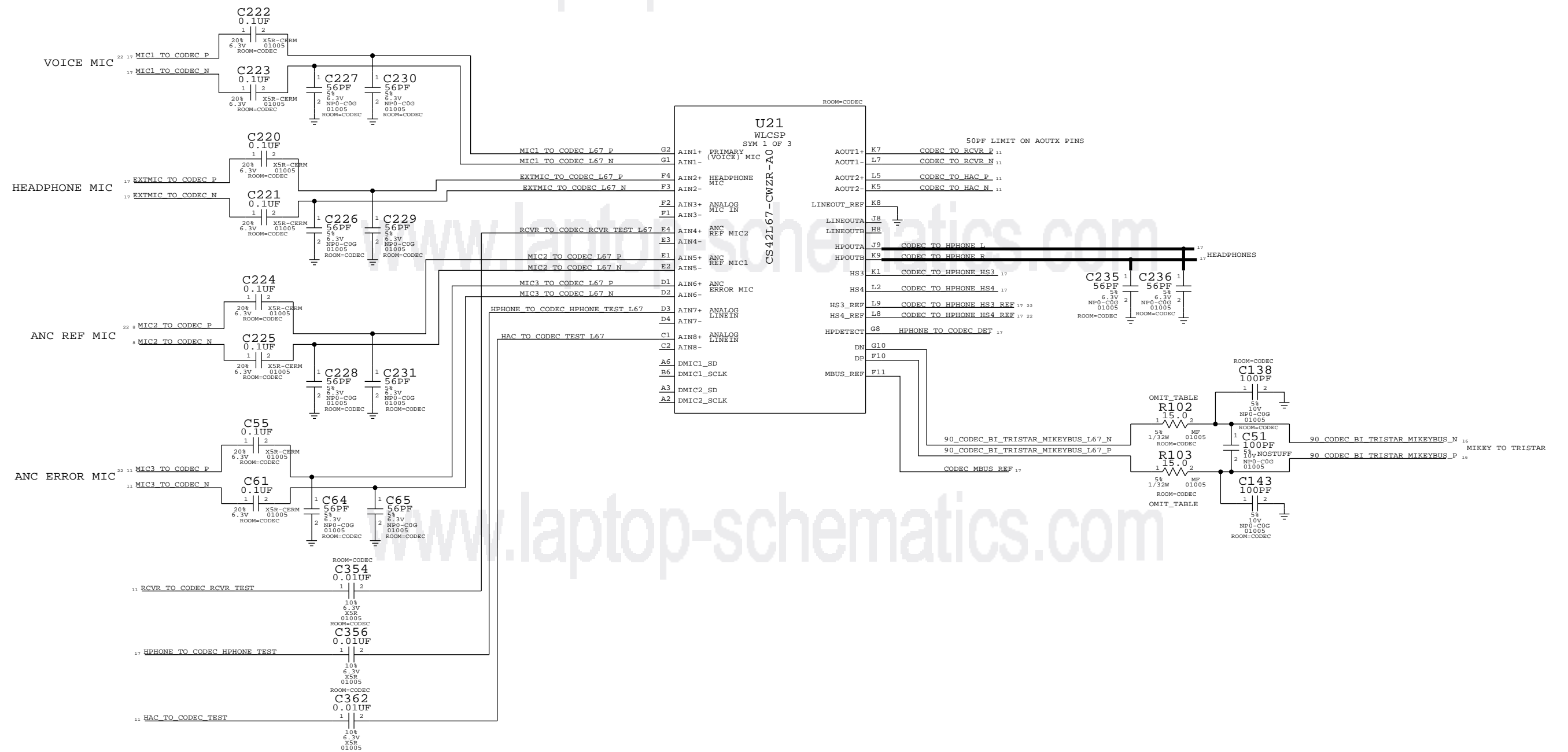

L67 AUDIO CODEC

POWER, MICBIAS

DIGITAL SYSTEM I/O

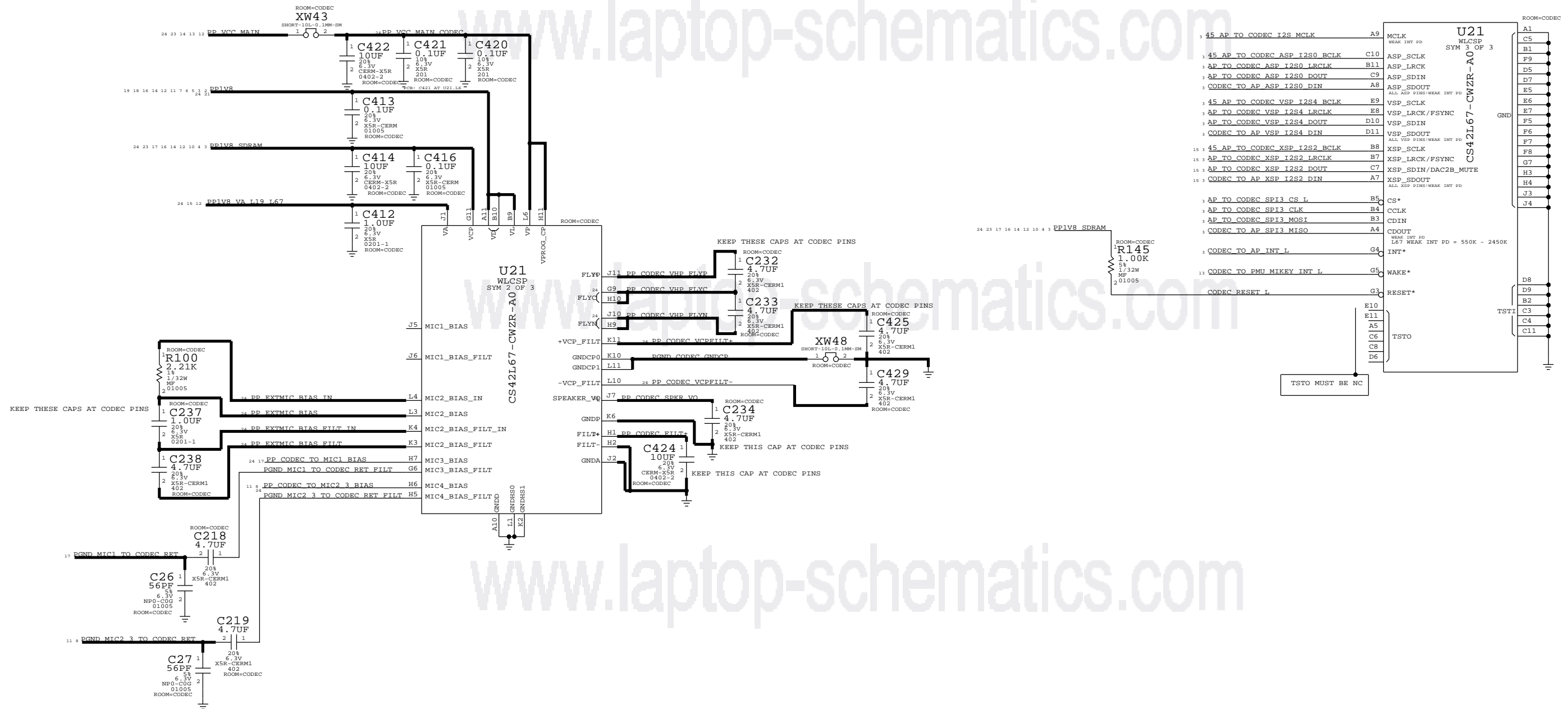

FRONT CAM FLEX B2B (FCAM, PROX, ALS, RECEIVER, ANC ERROR MIC)

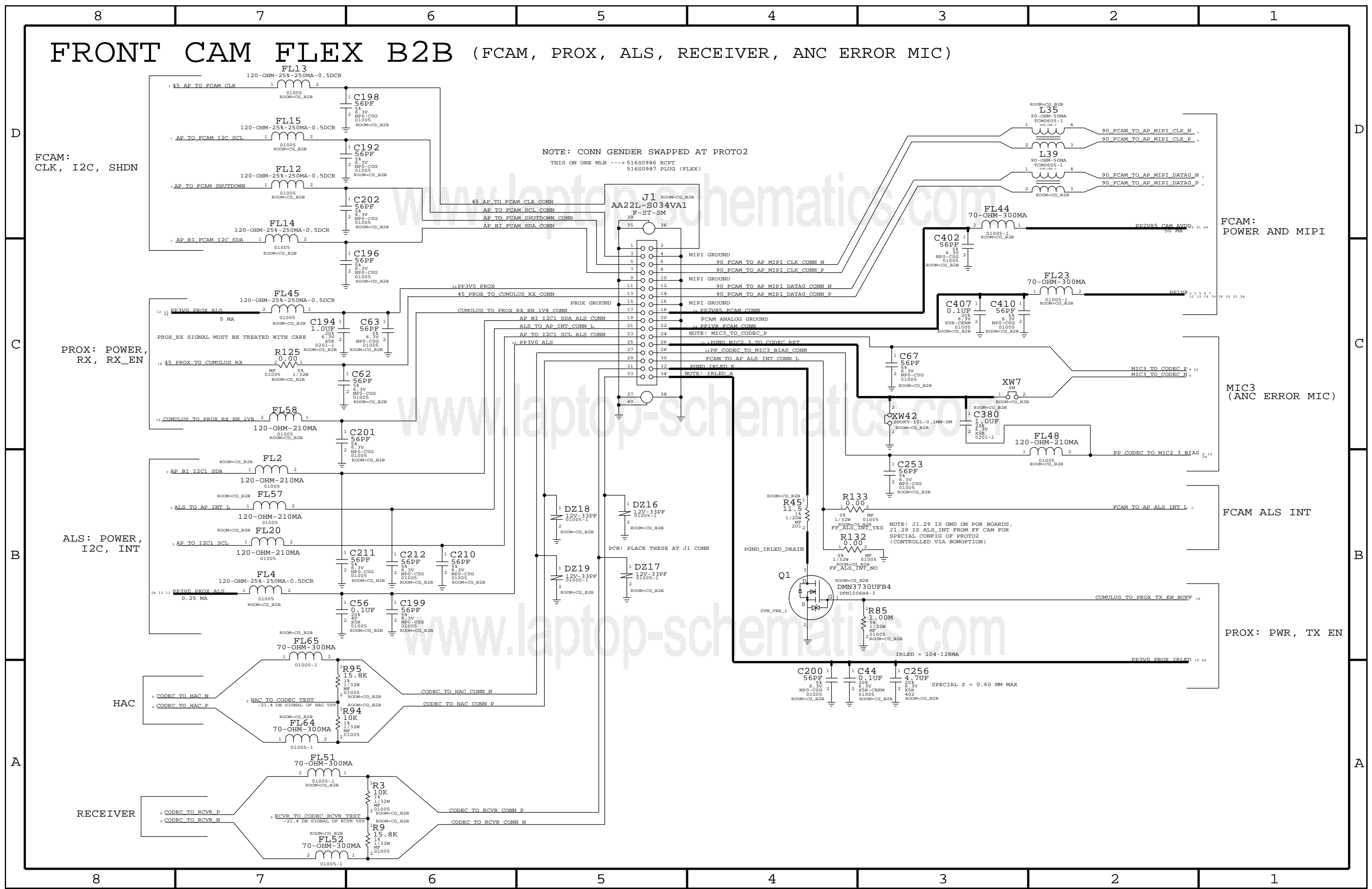

FCAM:
CLK, I2C, SHDN

PROX: POWER,
RX, RX_EN

ALS: POWER,
I2C, INT

HAC

RECEIVER

FCAM:
POWER AND MIPI

MIC3
(ANC ERROR MIC)

FCAM ALS INT

PROX: PWR, TX_EN

NOTE: CONN GENDER SWAPPED AT PROTO2
THIS ON ONE MLB ---> 516S0986 RCPT
516S0987 PLUG (FLEX)

NOTE: J1.29 IS GND ON FOR BOARDS,
J1.29 IS ALS_INT FROM FF CAM FOR
SPECIAL CONFIG OF PROTO2
(CONTROLLED VIA BOMOPTION)

PCB: PLACE THESE AT J1 CONN

SPECIAL Z = 0.60 MM MAX

AMBER PMU

(BUCK, LDO, VIBE DRIVER, 32K, CHARGER)

TO DO: GEERTJAN TO UPDATE VALUE OF R70 WITH H6P (EXPECTED TO CHANGE)

NOTE: L10, L12 BOMPTIONS CONTROLLED ON PAGE1

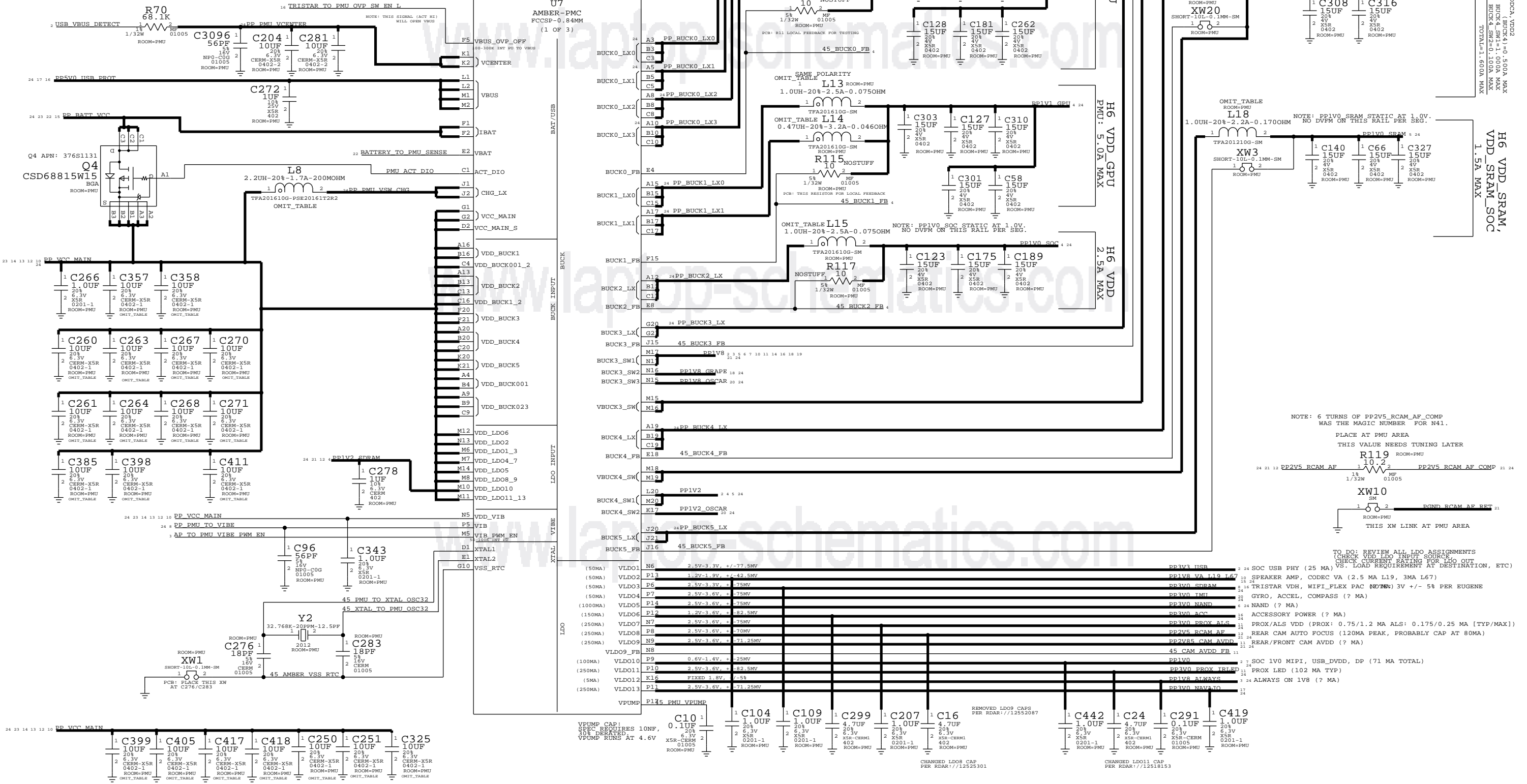

NOTE: 6 TURNS OF PP2V5_RCM_AF_COMP WAS THE MAGIC NUMBER FOR N41.

PLACE AT PMU AREA

THIS VALUE NEEDS TUNING LATER

R119

PP2V5_RCM_AF

PP2V5_RCM_AF_COMP

THIS XW LINK AT PMU AREA

TO DO: REVIEW ALL LDO ASSIGNMENTS (CHECK VDD LDO INPUT SOURCE)

CHECK CURRENT RATING FOR LDO OUT VS. LOAD REQUIREMENT AT DESTINATION, ETC)

Label	Value	Notes
VLD01	N6	2.5V-3.3V +/-77.5mV
VLD02	P13	1.2V-1.9V +/-42.5mV
VLD03	P6	2.5V-3.3V +/-75mV
VLD04	P7	2.5V-3.6V +/-75mV
VLD05	P14	2.5V-3.6V +/-75mV
VLD06	P2	1.2V-3.6V +/-82.5mV
VLD07	N7	2.5V-3.6V +/-75mV
VLD08	P8	2.5V-3.6V +/-70mV
VLD09	N9	2.5V-3.6V +/-71.25mV
VLD09_FB	N8	
VLD010	P9	0.6V-1.4V +/-25mV
VLD011	P10	2.5V-3.6V +/-82.5mV
VLD012	K16	FIXED 1.8V +/-5%
VLD013	P11	2.5V-3.6V +/-71.25mV
VPUMP	P15	PMU VEMP
PR3V3_USB		
PR1V8_VA_L19_L67		
PR3V0_SDRAM		
PR3V0_TMI		
PR3V0_NAND		
PR3V0_RTC		
PR3V0_NAND		
PR3V0_PROXY_ALS		
PR2V5_RCM_AF		
PR2V5_CAM_AVDD		
45_CAM_AVDD_FB		
PR1V0		
PR3V0_PROXY_TRILED		
PR1V8_ALWAYS		
PR3V0_NAVA_TO		

VPUMP CAP: SPEC REQUIRES 10NF, 30% DERATED, VPUMP RUNS AT 4.6V

C10 0.1UF 6.3V XSR-CERM 01005

C104 1.0UF 20V XSR-CERM 0201-1

C109 1.0UF 20V XSR-CERM 0201-1

C299 4.7UF 20V XSR-CERM 0201-1

C207 1.0UF 20V XSR-CERM 0201-1

C16 4.7UF 20V XSR-CERM 0201-1

C442 1.0UF 20V XSR-CERM 0201-1

C24 4.7UF 20V XSR-CERM 0201-1

C291 0.1UF 20V XSR-CERM 01005

C419 1.0UF 20V XSR-CERM 0201-1

REMOVED LDO9 CAPS PER RDAR://12525087

CHANGED LDO8 CAP PER RDAR://12525301

CHANGED LDO11 CAP PER RDAR://12518153

CHESTNUT, BACKLIGHT DRIVER, MESA BOOST

CHESTNUT BOM OPTIONS

PART#	QTY	DESCRIPTION	REFERENCE DESIGNATOR(S)	CRITICAL	BOM OPTION
338S1172	1	TI CHESTNUT	U3	Y	CHESTNUT_TI
152S1842	1	TI CHESTNUT IND - 1.5UH TAIYO	L19	Y	CHESTNUT_TI_TAIYO
152S1802	1	TI CHESTNUT IND - 1.5UH CYNTEC	L19	Y	CHESTNUT_TI_CYNTEC
338S1168	1	INTERSIL CHESTNUT	U3	Y	CHESTNUT_INTERSIL
152S1805	1	INTERSIL CHESTNUT IND - 2.2UH TFA-A	L19	Y	CHESTNUT_INTERSIL_TFA-A

D403 DISPLAY PMU (INTERSIL CHESTNUT, 338S1148) (TI CHESTNUT, 338S1149)

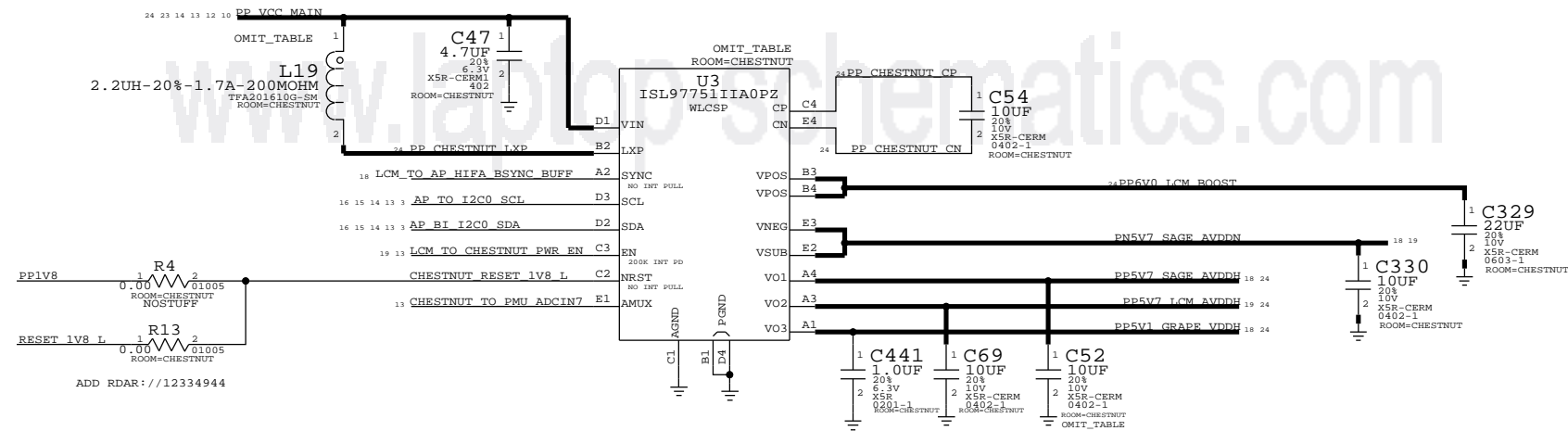

SAGE NEG BOOST TIMING INFO:

2 MS NOMIAL START UP DELAY FOR LCM POWER SEQUENCING
0 MS DELAY AT SHUTDOWN
ACTIVE DISCHARGE 2MS TO RAIL DOWN

D403 BACKLIGHT DRIVER

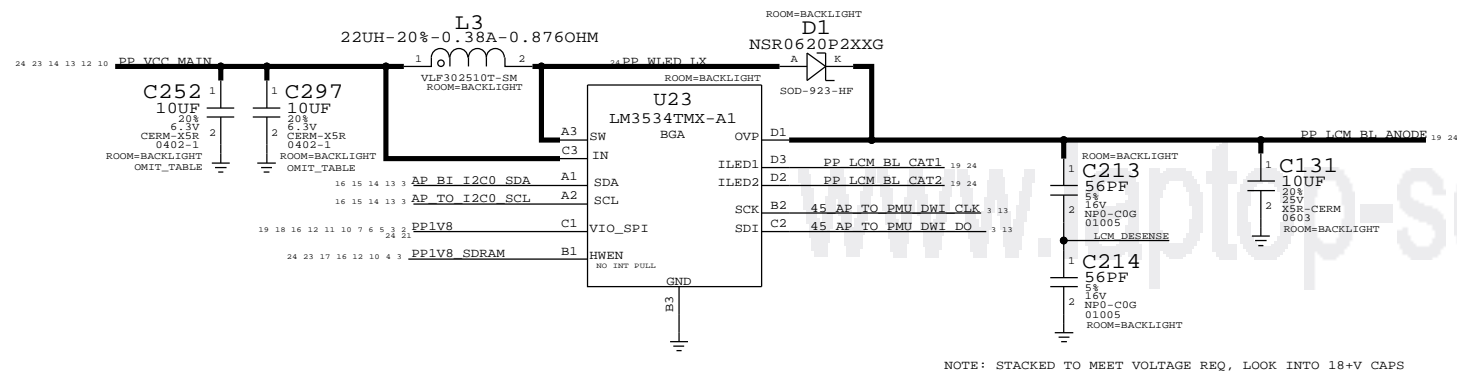

MESA BOOST

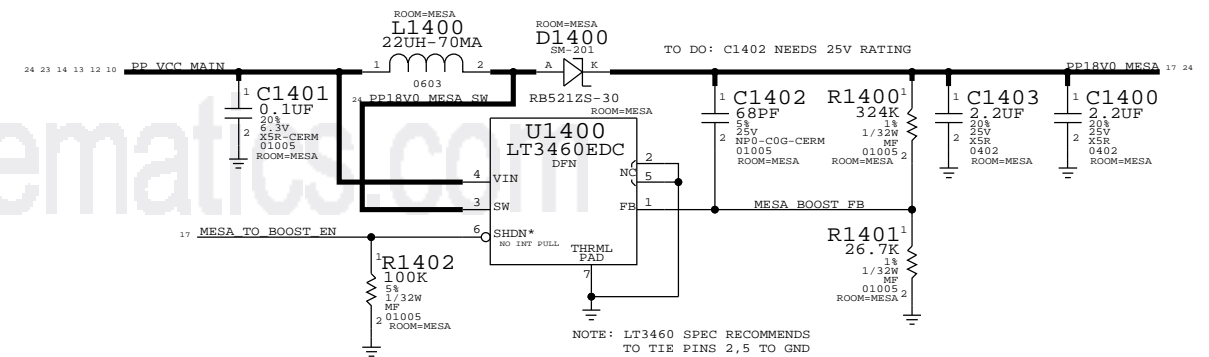

SPEAKER AMP, LED DRIVER

SPEAKER AMP (TO BE REPLACED WITH L20)

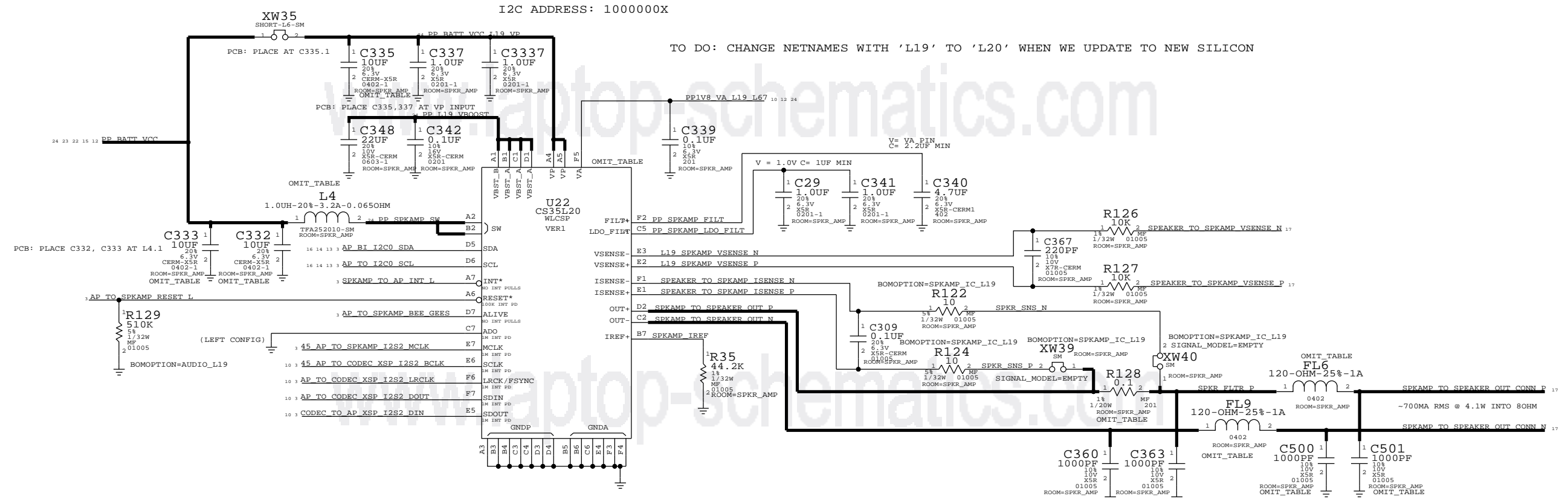

STROBE DRIVER (OPEL)

TI: APN 353S3899
FAIRCHILD: APN 353S3839

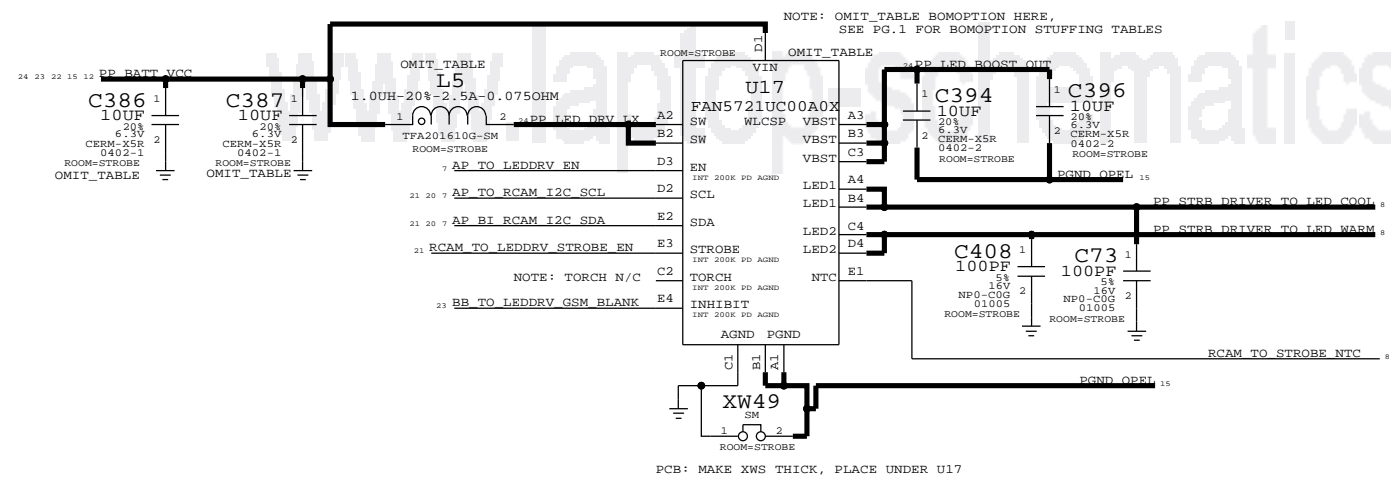

TRISTAR

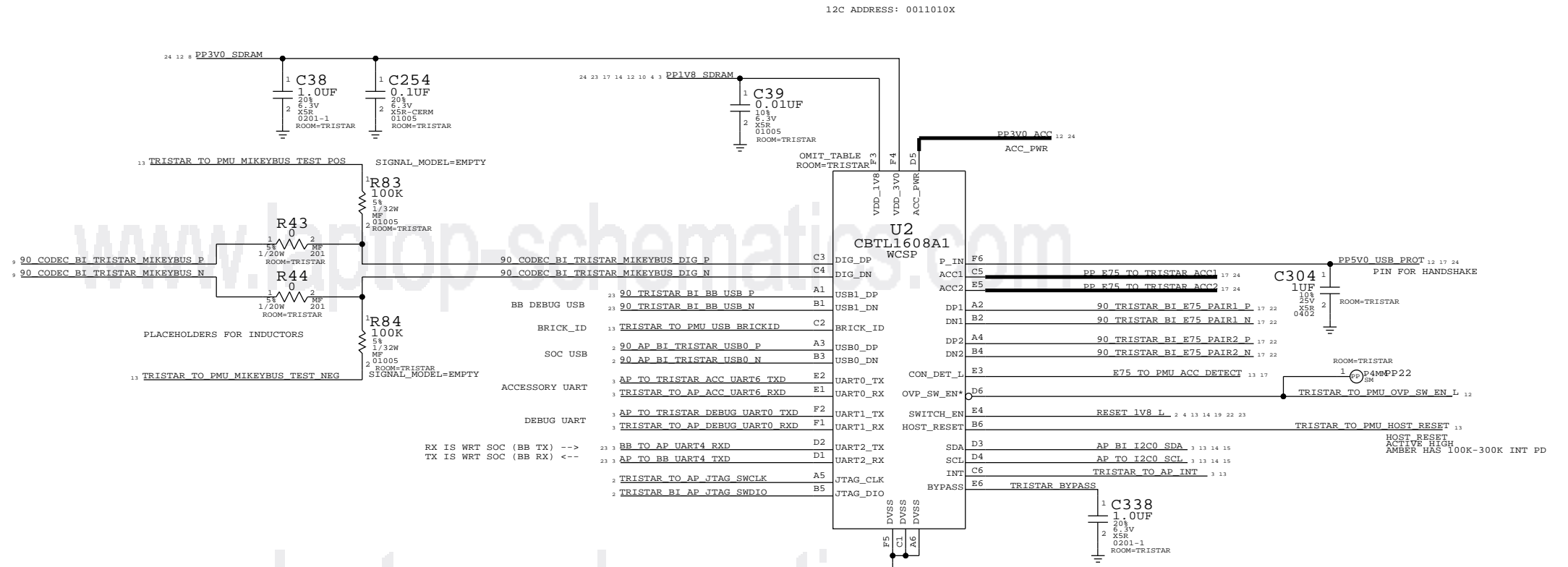
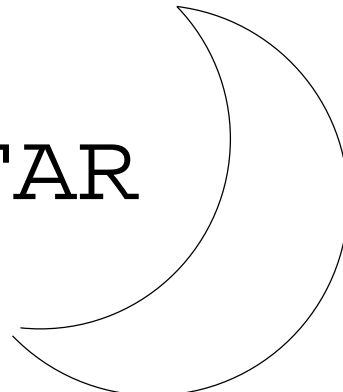

EEPROM

ONSEMI EEPROM
APN: 335S0894

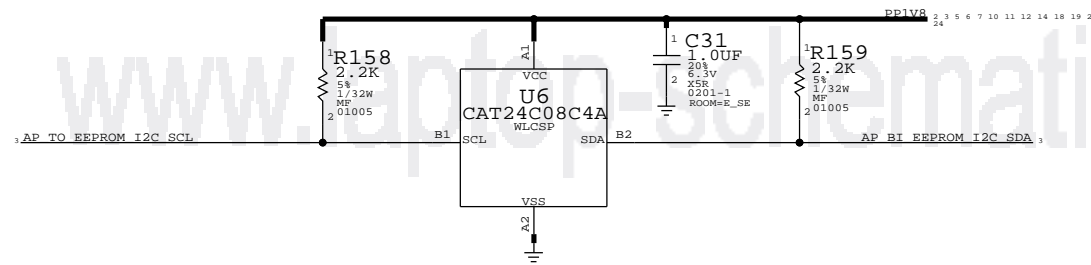

DOCKFLEX B2B (USB VBUS, MENU BTN, SPEAKER, HP, HP EXTMIC, NAVAJO, ANTENNA LAT SW CTRL, MIC1 (PRIMARY MIC), ACC DET/ID/PWR, E75 DIFFPAIRS)

NAVAJO:
VDD (1.8V)
VBOOST (18V)
BOOST_EN

HPHONE:
HS3/HS4,
HPDET,
HS3/HS4 REF,
(+EXTMIC)
HS3/HS4 CTRL

MENU BUTTON

MIC1
(PRIMARY MIC)

ANTENNA:
PAC 2.65V

SPEAKER:
SPEAKER LEADS
VSENSE,

USB VBUS

NAVAJO:
VDD (3.0V)
SPI

HPHONE AUDIO

BATTERY NTC

ANTENNA:
LAT SW CTRL

E75 DIFFPAIRS

ACCESSORY:
DETECT,
ID, PWR

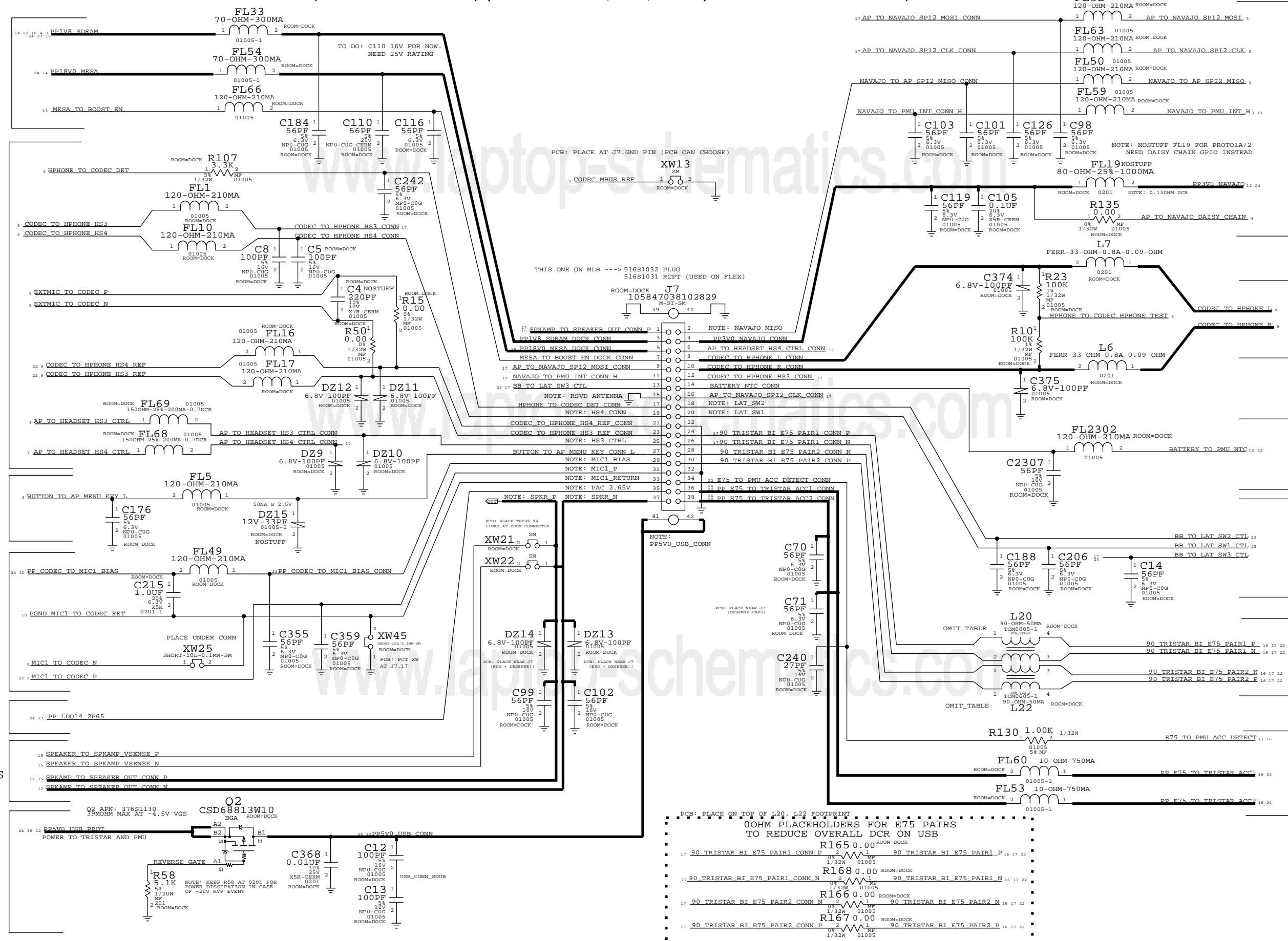

D403 (B2B, DRIVER ICS)

SAGE2 B06

CUMULUS C1

343S0638

(TURN ON LATER THAN PPIV8_GRAPE)
(TURN OFF SAME TIME AS PPIV8_GRAPE)

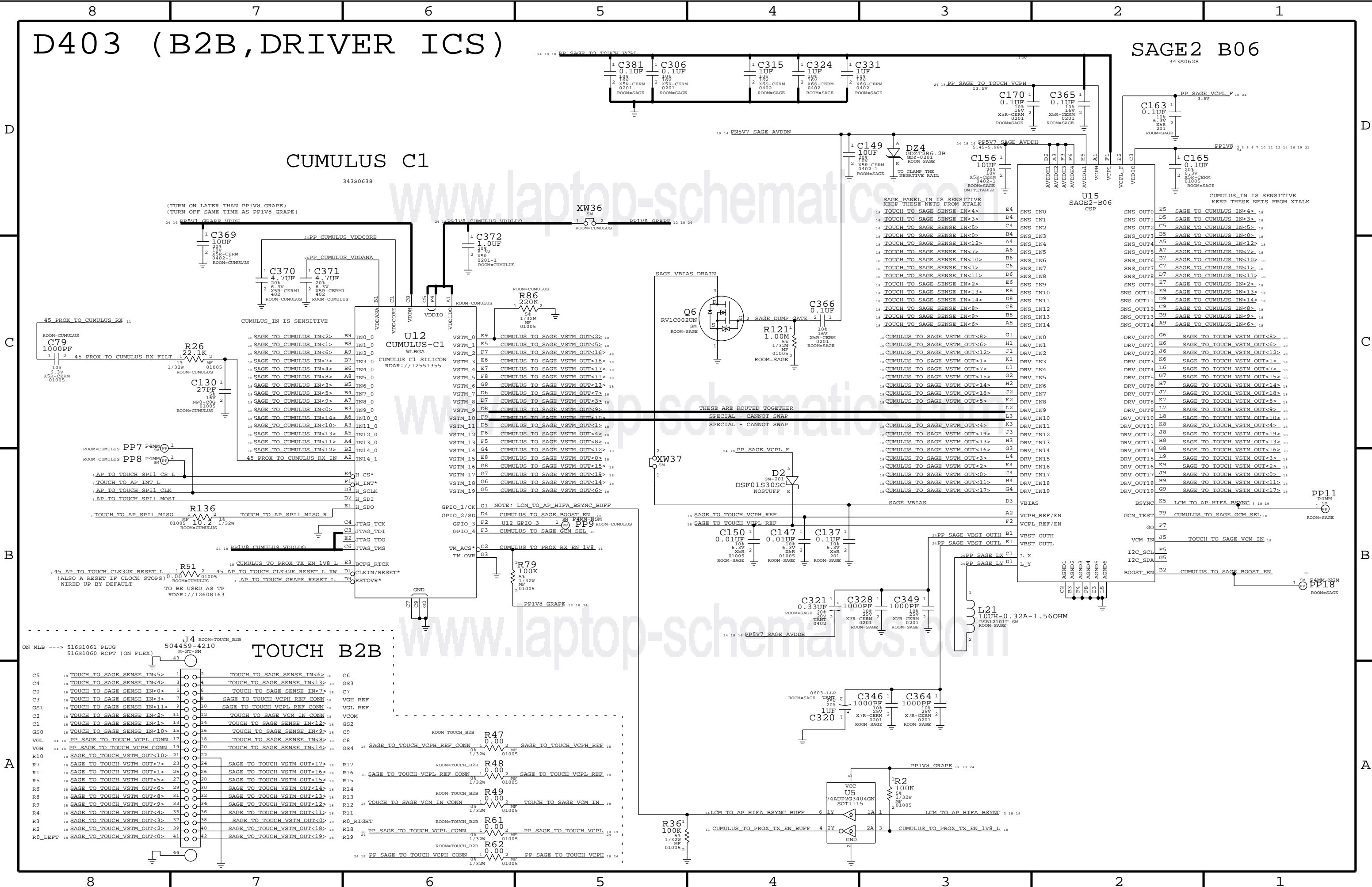

TOUCH B2B

ROOM=TOUCH_B2B

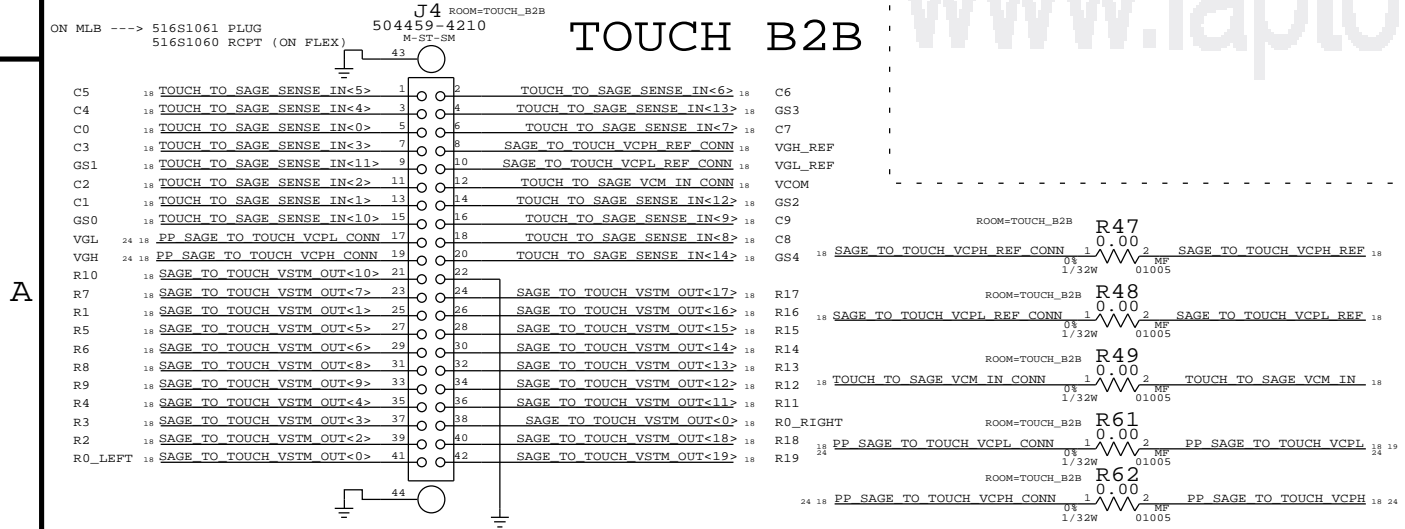

LCM B2B

LCM:
2-LANE MIPI

LCM:
POWER
(1.8V DVDD)
(+5.7V AVDD)
(-5.7V AVDD)

LCM:
DIGITAL I/F
(PWR_EN, RESET
PIFA, BSYNC)

LCM:
BACKLIGHT

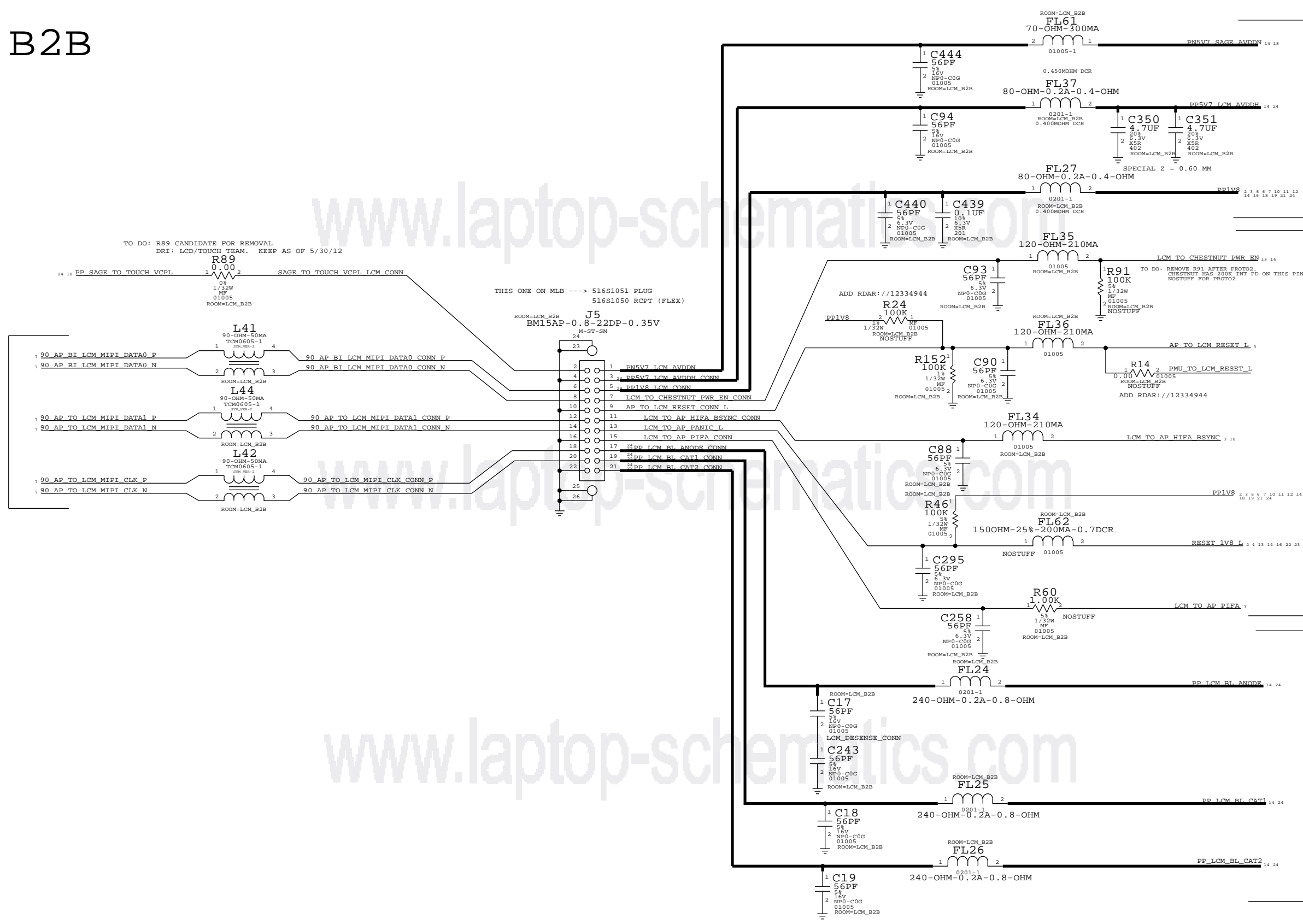

TO DO: R89 CANDIDATE FOR REMOVAL
DRI: LCD/TOUCH TEAM. KEEP AS OF 5/30/12

THIS ONE ON MLB ---> 516S1051 PLUG
516S1050 RCPT (FLEX)

TO DO: REMOVE R91 AFTER PROTO2.
CHESTNUT HAS 200K INT PD ON THIS PIN.
NOSTUFF FOR PROTO2.

ADD RDAR://12334944

PCB: ALL 56PF CAPS GO AT CONN

OSCAR + SENSORS

OSCAR MODULE (CONFORMAL COATED)

APN 337S4417

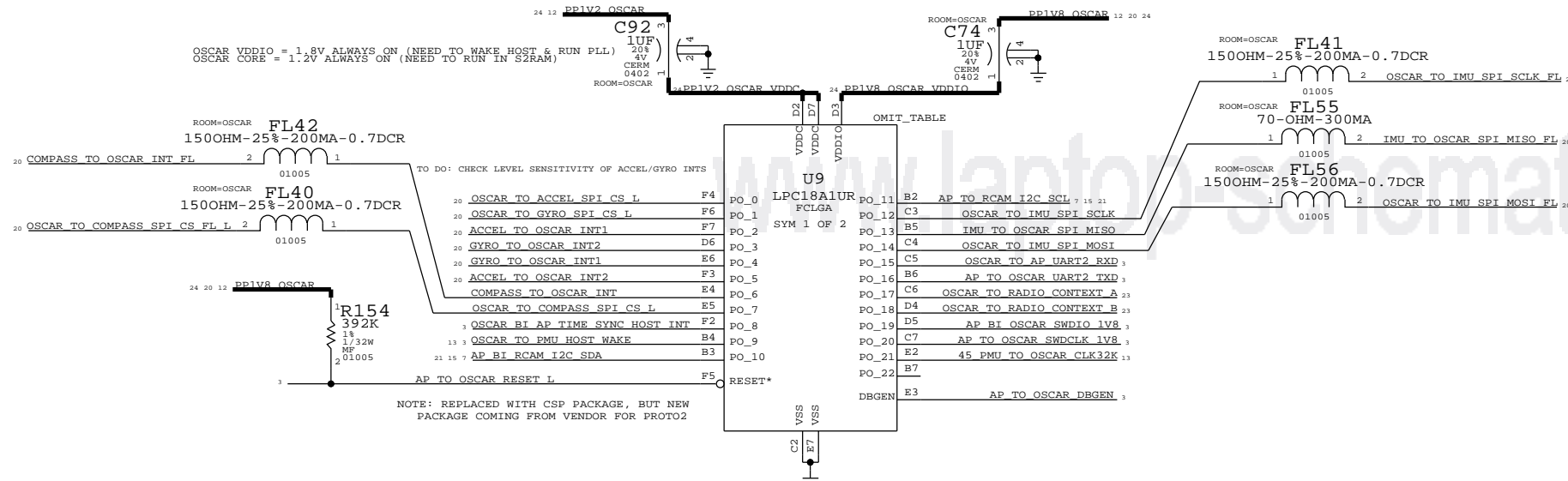

OSCAR MODULE GND BALLS
(THIS SYMBOL DOES NOT EXIST ON OSCAR CSP)

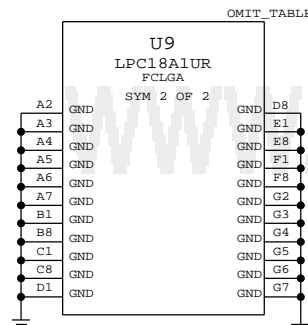

THIS PART OUTSIDE OF SHIELD

COMPASS

COMPASS CSP: 338S1014
COMPASS INTERPOSER (FOOTPRINT ONLY): 998-5120
COMPASS INTERPOSER MODULE: 639-4269

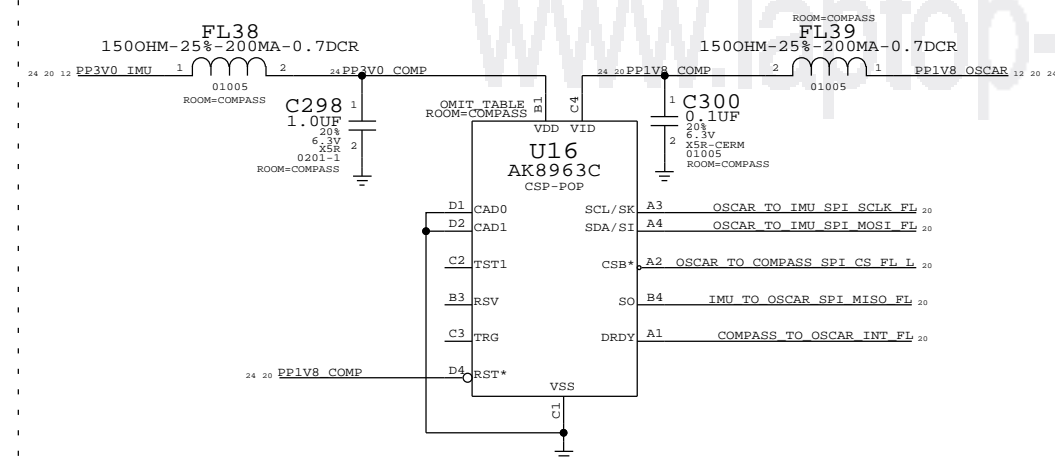

THESE PARTS INSIDE OF SHIELD

GYRO

X152: INVENSENSE ITG-3600, APN 338S1135

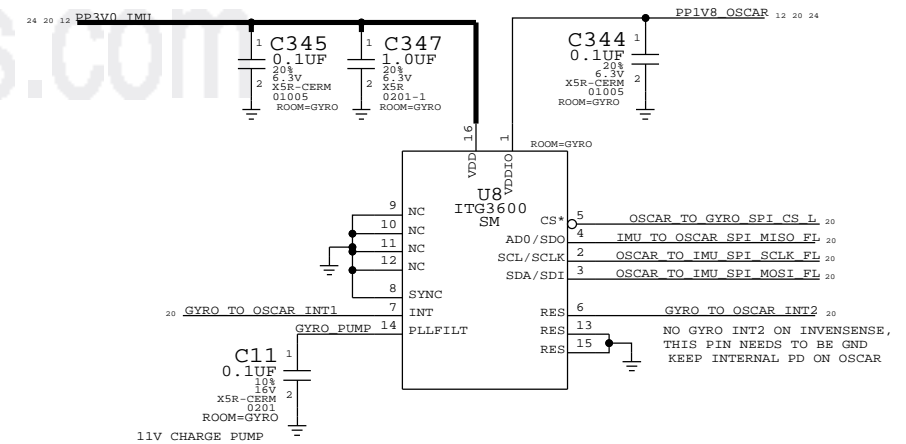

ACCELEROMETER

X152: BOSCH BMA282, APN 338S1163

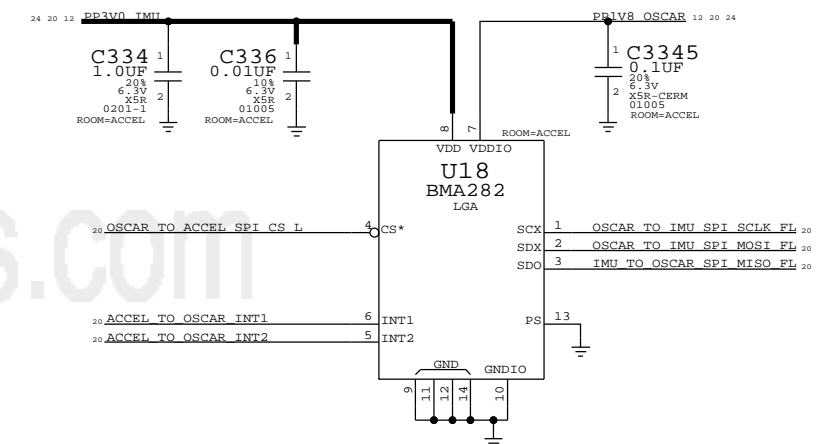

RCAM B2B (REAR CAMERA CONNECTOR)

RCAM:
POWER:
(1.8V DVDD)
(2.8V AVDD)
(1.2V VCC)
(2.5V AF)

RCAM:
DIGITAL I/F
(I2C, CTRL, CLK)

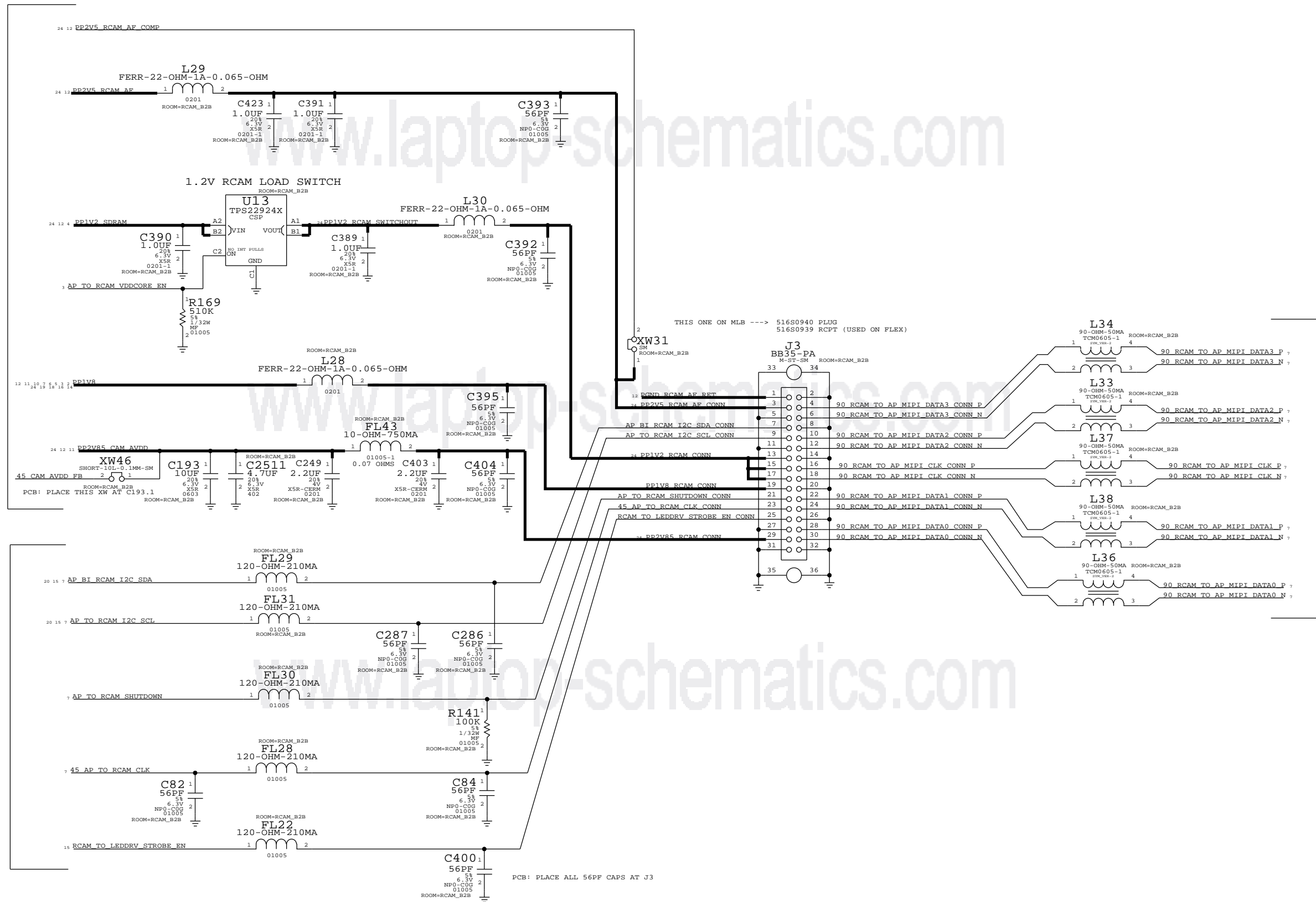

PCB: PLACE ALL 56PF CAPS AT J3

BATT CONN, TPS, STANDOFFS / SHIELDS / FIDUCIALS

BATTERY CONN

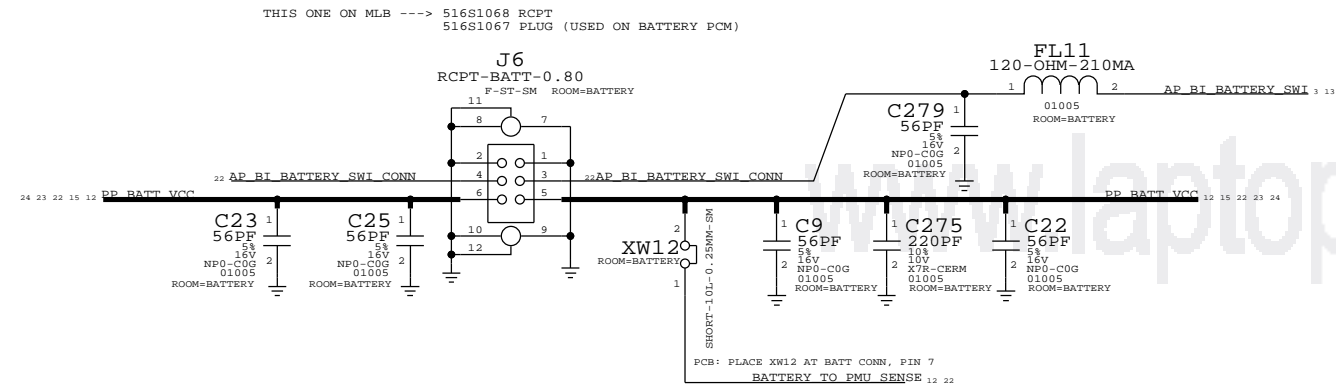

TESTPOINTS

POWER TP

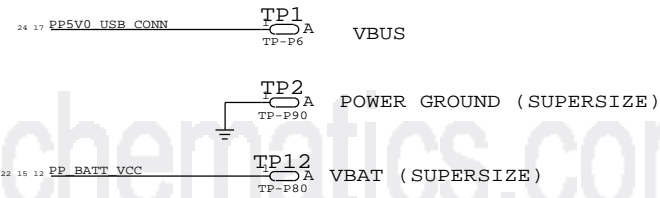

E75 - USB/UART/ID/POWER

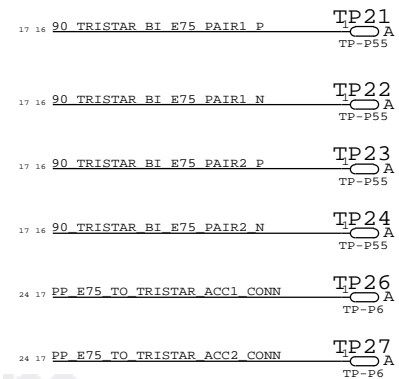

ACCESSORY ID AND POWER

SUPER TP

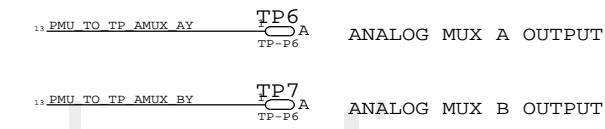

RESET

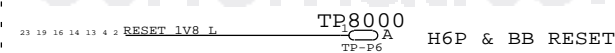

DFU

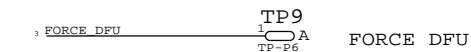

HEADPHONE MIC

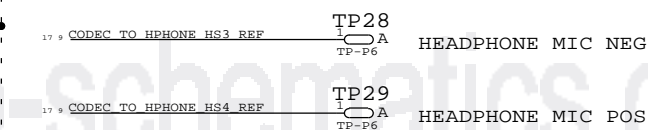

MIC AUDIO

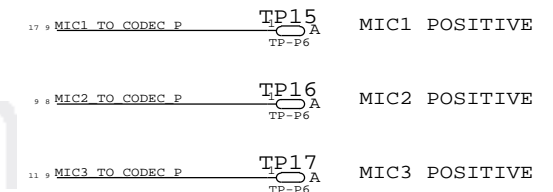

DRIVE MIC WRT NEAREST GROUND TEST POINT

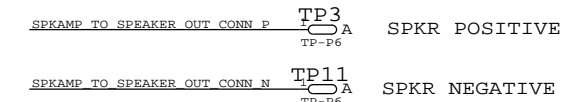

ADDED PER RDAR://12460740

LCM BACKLIGHT

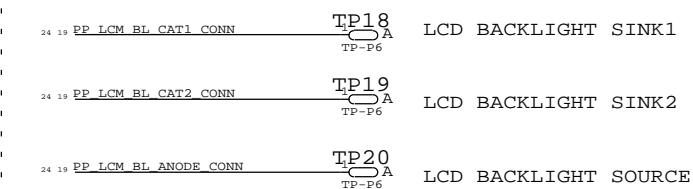

FIDUCIALS

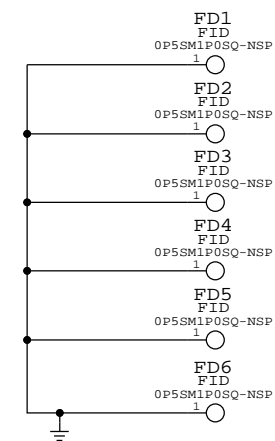

SHIELDS

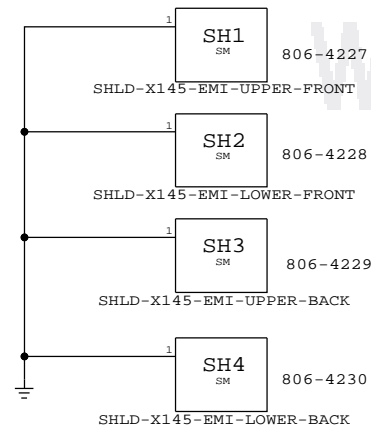

COWLING

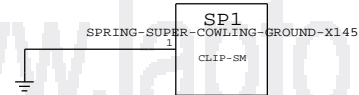

AC COUPLED SCREW HOLES + STANDOFFS (ON NORTH END OF SINGLE_BRD, TO MITIGATE COMPASS RETURN CURRENTS)

SCREW HOLES

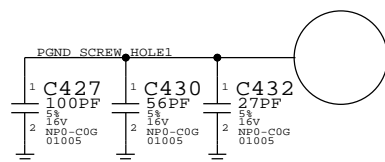

STANDOFFS

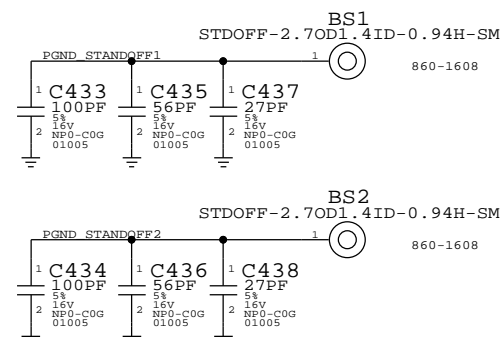

	8	7	6	5	4	3	2	1
18	VOLTAGE=4.55V CUMULUS_TO_SAGE_VSTM_OUT<0>							
19	VOLTAGE=4.55V CUMULUS_TO_SAGE_VSTM_OUT<1>							
20	VOLTAGE=4.55V CUMULUS_TO_SAGE_VSTM_OUT<2>							
21	VOLTAGE=4.55V CUMULUS_TO_SAGE_VSTM_OUT<3>							
22	VOLTAGE=4.55V CUMULUS_TO_SAGE_VSTM_OUT<4>							
23	VOLTAGE=4.55V CUMULUS_TO_SAGE_VSTM_OUT<5>							
24	VOLTAGE=4.55V CUMULUS_TO_SAGE_VSTM_OUT<6>							
25	VOLTAGE=4.55V CUMULUS_TO_SAGE_VSTM_OUT<7>							
26	VOLTAGE=4.55V CUMULUS_TO_SAGE_VSTM_OUT<8>							
27	VOLTAGE=4.55V CUMULUS_TO_SAGE_VSTM_OUT<9>							
28	VOLTAGE=4.55V CUMULUS_TO_SAGE_VSTM_OUT<10>							
29	VOLTAGE=4.55V CUMULUS_TO_SAGE_VSTM_OUT<11>							
30	VOLTAGE=4.55V CUMULUS_TO_SAGE_VSTM_OUT<12>							
31	VOLTAGE=4.55V CUMULUS_TO_SAGE_VSTM_OUT<13>							
32	VOLTAGE=4.55V CUMULUS_TO_SAGE_VSTM_OUT<14>							
33	VOLTAGE=4.55V CUMULUS_TO_SAGE_VSTM_OUT<15>							
34	VOLTAGE=4.55V CUMULUS_TO_SAGE_VSTM_OUT<16>							
35	VOLTAGE=4.55V CUMULUS_TO_SAGE_VSTM_OUT<17>							
36	VOLTAGE=4.55V CUMULUS_TO_SAGE_VSTM_OUT<18>							
37	VOLTAGE=4.55V CUMULUS_TO_SAGE_VSTM_OUT<19>							
38	VOLTAGE=4.55V TOUCH_TO_SAGE_SENSE_IN<0>							
39	VOLTAGE=4.55V TOUCH_TO_SAGE_SENSE_IN<1>							
40	VOLTAGE=4.55V TOUCH_TO_SAGE_SENSE_IN<2>							
41	VOLTAGE=4.55V TOUCH_TO_SAGE_SENSE_IN<3>							
42	VOLTAGE=4.55V TOUCH_TO_SAGE_SENSE_IN<4>							
43	VOLTAGE=4.55V TOUCH_TO_SAGE_SENSE_IN<5>							
44	VOLTAGE=4.55V TOUCH_TO_SAGE_SENSE_IN<6>							
45	VOLTAGE=4.55V TOUCH_TO_SAGE_SENSE_IN<7>							
46	VOLTAGE=4.55V TOUCH_TO_SAGE_SENSE_IN<8>							
47	VOLTAGE=4.55V TOUCH_TO_SAGE_SENSE_IN<9>							
48	VOLTAGE=4.55V TOUCH_TO_SAGE_SENSE_IN<10>							
49	VOLTAGE=4.55V TOUCH_TO_SAGE_SENSE_IN<11>							
50	VOLTAGE=4.55V TOUCH_TO_SAGE_SENSE_IN<12>							
51	VOLTAGE=4.55V TOUCH_TO_SAGE_SENSE_IN<13>							
52	VOLTAGE=4.55V TOUCH_TO_SAGE_SENSE_IN<14>							
53	VOLTAGE=4.55V SAGE_TO_TOUCH_VSTM_OUT<0>							
54	VOLTAGE=4.55V SAGE_TO_TOUCH_VSTM_OUT<1>							
55	VOLTAGE=4.55V SAGE_TO_TOUCH_VSTM_OUT<2>							
56	VOLTAGE=4.55V SAGE_TO_TOUCH_VSTM_OUT<3>							
57	VOLTAGE=4.55V SAGE_TO_TOUCH_VSTM_OUT<4>							
58	VOLTAGE=4.55V SAGE_TO_TOUCH_VSTM_OUT<5>							
59	VOLTAGE=4.55V SAGE_TO_TOUCH_VSTM_OUT<6>							
60	VOLTAGE=4.55V SAGE_TO_TOUCH_VSTM_OUT<7>							
61	VOLTAGE=4.55V SAGE_TO_TOUCH_VSTM_OUT<8>							
62	VOLTAGE=4.55V SAGE_TO_TOUCH_VSTM_OUT<9>							
63	VOLTAGE=4.55V SAGE_TO_TOUCH_VSTM_OUT<10>							
64	VOLTAGE=4.55V SAGE_TO_TOUCH_VSTM_OUT<11>							
65	VOLTAGE=4.55V SAGE_TO_TOUCH_VSTM_OUT<12>							
66	VOLTAGE=4.55V SAGE_TO_TOUCH_VSTM_OUT<13>							
67	VOLTAGE=4.55V SAGE_TO_TOUCH_VSTM_OUT<14>							
68	VOLTAGE=4.55V SAGE_TO_TOUCH_VSTM_OUT<15>							
69	VOLTAGE=4.55V SAGE_TO_TOUCH_VSTM_OUT<16>							
70	VOLTAGE=4.55V SAGE_TO_TOUCH_VSTM_OUT<17>							
71	VOLTAGE=4.55V SAGE_TO_TOUCH_VSTM_OUT<18>							
72	VOLTAGE=4.55V SAGE_TO_TOUCH_VSTM_OUT<19>							
11	VOLTAGE=3.8V CODEC_TO_RCVR_P							
12	VOLTAGE=3.8V CODEC_TO_RCVR_N							
13	VOLTAGE=3.8V CODEC_TO_RCVR_CONN_P							
14	VOLTAGE=3.8V CODEC_TO_RCVR_CONN_N							
15	VOLTAGE=3.8V CODEC_TO_HAC_P							
16	VOLTAGE=3.8V CODEC_TO_HAC_N							
17	VOLTAGE=3.8V CODEC_TO_HAC_CONN_P							
18	VOLTAGE=3.8V CODEC_TO_HAC_CONN_N							
19	VOLTAGE=3.114V CODEC_TO_HPHONE_L							
20	VOLTAGE=3.114V CODEC_TO_HPHONE_R							
21	VOLTAGE=3.114V CODEC_TO_HPHONE_L_CONN							
22	VOLTAGE=3.114V CODEC_TO_HPHONE_R_CONN							
23	VOLTAGE=2.7V CODEC_TO_HPHONE_HS3							
24	VOLTAGE=2.7V CODEC_TO_HPHONE_HS4							
25	VOLTAGE=2.7V CODEC_TO_HPHONE_HS3_REF							
26	VOLTAGE=2.7V CODEC_TO_HPHONE_HS4_REF							
27	VOLTAGE=2.7V CODEC_TO_HPHONE_HS3_CONN							
28	VOLTAGE=2.7V CODEC_TO_HPHONE_HS4_CONN							
29	VOLTAGE=2.7V CODEC_TO_HPHONE_HS4_REF_CONN							
30	VOLTAGE=4.3V HPHONE_TO_CODEC_DET							
31	VOLTAGE=4.3V HPHONE_TO_CODEC_DET_CONN							
32	VOLTAGE=2.5V 90_CODEC_BI_TRISTAR_MIKEYBUS_L67_P							
33	VOLTAGE=2.5V 90_CODEC_BI_TRISTAR_MIKEYBUS_L67_N							
34	VOLTAGE=2.5V 90_CODEC_BI_TRISTAR_MIKEYBUS_P							
35	VOLTAGE=2.5V 90_CODEC_BI_TRISTAR_MIKEYBUS_N							
36	VOLTAGE=2.5V 90_CODEC_BI_TRISTAR_MIKEYBUS_DIG_P							
37	VOLTAGE=2.5V 90_CODEC_BI_TRISTAR_MIKEYBUS_DIG_N							
38	VOLTAGE=2.5V TRISTAR_TO_PMU_MIKEYBUS_TEST_POS							
39	VOLTAGE=2.5V TRISTAR_TO_PMU_MIKEYBUS_TEST_NEG							
40	VOLTAGE=1.8V MIC1_TO_CODEC_L67_P							
41	VOLTAGE=1.8V MIC1_TO_CODEC_L67_N							
42	VOLTAGE=1.8V MIC1_TO_CODEC_P							
43	VOLTAGE=1.8V MIC1_TO_CODEC_N							
44	VOLTAGE=1.8V MIC2_TO_CODEC_L67_P							
45	VOLTAGE=1.8V MIC2_TO_CODEC_L67_N							
46	VOLTAGE=1.8V MIC2_TO_CODEC_P							
47	VOLTAGE=1.8V MIC2_TO_CODEC_N							
48	VOLTAGE=1.8V MIC3_TO_CODEC_L67_P							
49	VOLTAGE=1.8V MIC3_TO_CODEC_L67_N							
50	VOLTAGE=1.8V MIC3_TO_CODEC_P							
51	VOLTAGE=1.8V MIC3_TO_CODEC_N							
52	VOLTAGE=3.8V RCVR_TO_CODEC_RCVR_TEST							
53	VOLTAGE=3.8V RCVR_TO_CODEC_RCVR_TEST_L67							
54	VOLTAGE=3.114V HPHONE_TO_CODEC_HPHONE_TEST							
55	VOLTAGE=3.114V HPHONE_TO_CODEC_HPHONE_TEST_L67							
56	VOLTAGE=3.8V HAC_TO_CODEC_TEST							
57	VOLTAGE=3.8V HAC_TO_CODEC_TEST_L67							
58	VOLTAGE=2.85V 45_CAM_AVDD_FB							
59	VOLTAGE=4.6V 45_PMU_VBUMP							
60	VOLTAGE=4.3V PMU_ACT_DIO							
61	VOLTAGE=3.6V TRISTAR_TO_PMU_OVP_SW_EN_L							
62	VOLTAGE=3.2V USB_VBUS_DETECT							
63	VOLTAGE=5.25V TRISTAR_TO_PMU_USB_BRICKID							
64	VOLTAGE=5.25V TRISTAR_TO_PMU_USB_BRICKID_R							
22	VOLTAGE=2.5V BATTERY_TO_PMU_NTC							
23	VOLTAGE=2.5V BATTERY_NTC_CONN							
24	VOLTAGE=4.2V BATTERY_TO_PMU_SENSE							
25	VOLTAGE=1.8V MESA_BOOST_FB							
26	VOLTAGE=8V SPEAKER_TO_SPKAMP_VSENSE_P							
27	VOLTAGE=8V SPEAKER_TO_SPKAMP_VSENSE_N							
28	VOLTAGE=8V L19_SPKAMP_VSENSE_P							
29	VOLTAGE=8V L19_SPKAMP_VSENSE_N							
30	VOLTAGE=8V SPEAKER_TO_SPKAMP_ISENSE_P							
31	VOLTAGE=8V SPEAKER_TO_SPKAMP_ISENSE_N							
32	VOLTAGE=8V SPKR_SNS_P							
33	VOLTAGE=8V SPKR_SNS_N							
34	VOLTAGE=8V SPKR_FLTR_P							
35	VOLTAGE=8V SPKAMP_TO_SPEAKER_OUT_CONN_P							
36	VOLTAGE=8V SPKAMP_TO_SPEAKER_OUT_CONN_N							
37	VOLTAGE=8V SPKAMP_TO_SPEAKER_OUT_P							
38	VOLTAGE=8V SPKAMP_TO_SPEAKER_OUT_N							
39	VOLTAGE=5.25V 90_TRISTAR_BI_E75_PAIR1_P							
40	VOLTAGE=5.25V 90_TRISTAR_BI_E75_PAIR1_N							
41	VOLTAGE=5.25V 90_TRISTAR_BI_E75_PAIR2_P							
42	VOLTAGE=5.25V 90_TRISTAR_BI_E75_PAIR2_N							
43	VOLTAGE=5.25V 90_TRISTAR_BI_E75_PAIR1_CONN_P							
44	VOLTAGE=5.25V 90_TRISTAR_BI_E75_PAIR1_CONN_N							
45	VOLTAGE=5.25V 90_TRISTAR_BI_E75_PAIR2_CONN_P							
46	VOLTAGE=5.25V 90_TRISTAR_BI_E75_PAIR2_CONN_N							
47	VOLTAGE=3.0V TRISTAR_BYPASS							
48	VOLTAGE=-5.7V PNV57_SAGE_AVDDN							
49	VOLTAGE=-5.7V PNV57_LCM_AVDDN							
50	VOLTAGE=-5.7V SAGE_DUMP_GATE							
51	VOLTAGE=2.5V SAGE_VBIAS							
52	VOLTAGE=2.5V SAGE_VBIAS_DRAIN							
53	VOLTAGE=-1.2V SAGE_TO_TOUCH_VCPL_LCM_CONN							
54	VOLTAGE=1.1V GYRO_PUMP							
55	VOLTAGE=XV SAGE_TO_CUMULUS_IN<0>							
56	VOLTAGE=XV SAGE_TO_CUMULUS_IN<1>							
57	VOLTAGE=XV SAGE_TO_CUMULUS_IN<2>							
58	VOLTAGE=XV SAGE_TO_CUMULUS_IN<3>							
59	VOLTAGE=XV SAGE_TO_CUMULUS_IN<4>							
60	VOLTAGE=XV SAGE_TO_CUMULUS_IN<5>							
61	VOLTAGE=XV SAGE_TO_CUMULUS_IN<6>							
62	VOLTAGE=XV SAGE_TO_CUMULUS_IN<7>							
63	VOLTAGE=XV SAGE_TO_CUMULUS_IN<8>							
64	VOLTAGE=XV SAGE_TO_CUMULUS_IN<9>							
65	VOLTAGE=XV SAGE_TO_CUMULUS_IN<10>							
66	VOLTAGE=XV SAGE_TO_CUMULUS_IN<11>							
67	VOLTAGE=XV SAGE_TO_CUMULUS_IN<12>							
68	VOLTAGE=XV SAGE_TO_CUMULUS_IN<13>							
69	VOLTAGE=18.0V PP16V5_MESA							
70	VOLTAGE=18.0V PP16V5_MESA_DOCK_CONN							
71	VOLTAGE=18.0V PP16V5_MESA_SW							
72	VOLTAGE=1.0V PP1V0							
73	VOLTAGE=1.0V PP1V0_SOC							
74	VOLTAGE=1.0V PP1V0_SRAM							
75	VOLTAGE=1.1V PP1V1_CPU							
76	VOLTAGE=1.1V PP1V1_GPU							
77	VOLTAGE=1.2V PP1V2							
78	VOLTAGE=1.2V PP1V2_NAND_VDDI							
79	VOLTAGE=1.2V PP1V2_OSCAR							
80	VOLTAGE=1.2V PP1V2_OSCAR_VDDC			</				

RADIO_MLB HIERARCHICAL SYMBOL

AP/RADIO INTERFACE



BOARD_ID BOM OPTIONS

PART#	QTY	DESCRIPTION	REFERENCE DESIGNATOR(S)	CRITICAL	BOM OPTION
118S0621	1	1.00M 1% 01005	R25_RF	Y	N51_CFG_A
118S0732	1	50K 1% 01005	R26_RF	Y	N51_CFG_A
117S0159	1	470K 5% 01005	R25_RF	Y	N51_CFG_B
118S0626	1	100K 1% 01005	R26_RF	Y	N51_CFG_B
118S0626	1	100K 1% 01005	R25_RF	Y	N53_CFG_A
118S0726	1	162K 1% 01005	R26_RF	Y	N53_CFG_A
118S0626	1	100K 1% 01005	R25_RF	Y	N53_CFG_B
118S0623	1	267K 1% 01005	R26_RF	Y	N53_CFG_B
118S0659	1	255K 1% 01005	R25_RF	Y	N48_CFG_A
118S0626	1	100K 1% 01005	R26_RF	Y	N48_CFG_A
118S0689	1	147K 1% 01005	R26_RF	Y	N48_CFG_B
118S0626	1	100K 1% 01005	R26_RF	Y	N48_CFG_B
118S0626	1	100K 1% 01005	R25_RF	Y	N49_CFG_A
118S0650	1	499K 1% 01005	R26_RF	Y	N49_CFG_A
118S0732	1	50K 1% 01005	R25_RF	Y	N49_CFG_B
118S0621	1	1.00M 1% 01005	R26_RF	Y	N49_CFG_B

PDF PAGE	CSA PAGE	CONTENTS
2	2	AP INTERFACE & DEBUG CONNECTORS
3	3	PMU (1 OF 2)
4	4	PMU (2 OF 2)
5	5	BASEBAND (1 OF 2)
6	6	BASEBAND (2 OF 2)
7	7	RF TRANSCEIVER (1 OF 2)
8	8	RF TRANSCEIVER (2 OF 2)
9	9	RX MATCHING
10	10	TX INTERSTAGE FILTERS
11	11	BAND 1/34/39/38/40 TX
12	12	BAND 2/3 PAD
13	13	BAND 7/20 PAD
14	14	BAND 5/8 PAD
15	15	2G PA
16	16	PA DCDC CONVERTER
17	17	PRIMARY ASM
18	18	RX DIVERSITY
19	19	GPS
20	20	ANTENNA FEEDS
21	21	SWITCH LOGIC
22	22	BLANK
23	23	WIFI/BT

BOARD_ID BOM OPTIONS

PART#	QTY	DESCRIPTION	REFERENCE DESIGNATOR(S)	CRITICAL	BOM OPTION
118S0621	1	1.00M 1% 01005	R25_RF	Y	N51_CFG_A
118S0732	1	50K 1% 01005	R26_RF	Y	N51_CFG_A
117S0159	1	470K 5% 01005	R25_RF	Y	N51_CFG_B
118S0626	1	100K 1% 01005	R26_RF	Y	N51_CFG_B
118S0626	1	100K 1% 01005	R25_RF	Y	N53_CFG_A
118S0726	1	162K 1% 01005	R26_RF	Y	N53_CFG_A
118S0626	1	100K 1% 01005	R25_RF	Y	N53_CFG_B
118S0623	1	267K 1% 01005	R26_RF	Y	N53_CFG_B
118S0659	1	255K 1% 01005	R25_RF	Y	N48_CFG_A
118S0626	1	100K 1% 01005	R26_RF	Y	N48_CFG_A
118S0689	1	147K 1% 01005	R26_RF	Y	N48_CFG_B
118S0626	1	100K 1% 01005	R26_RF	Y	N48_CFG_B
118S0626	1	100K 1% 01005	R25_RF	Y	N49_CFG_A
118S0650	1	499K 1% 01005	R26_RF	Y	N49_CFG_A
118S0732	1	50K 1% 01005	R25_RF	Y	N49_CFG_B
118S0621	1	1.00M 1% 01005	R26_RF	Y	N49_CFG_B

SCH : 951-2770
 BOM : 639-3973
 BOARD : 820-3382

PART#	QTY	DESCRIPTION	REFERENCE DESIGNATOR(S)	CRITICAL	BOM OPTION
951-2445	1	X152_RADIO_MLB	SCH	Y	
825-2029	1	EEE FOR 939-0308	EEEE_????	Y	NA

AP INTERFACE & DEBUG CONNECTORS

AP CONNECTIONS

IN = FROM AP
OUT = TO AP

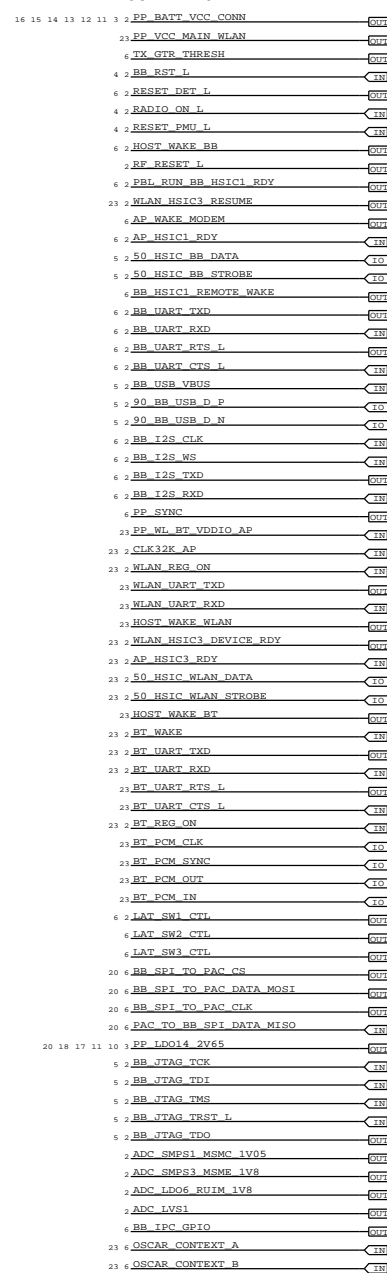

PROBE POINTS

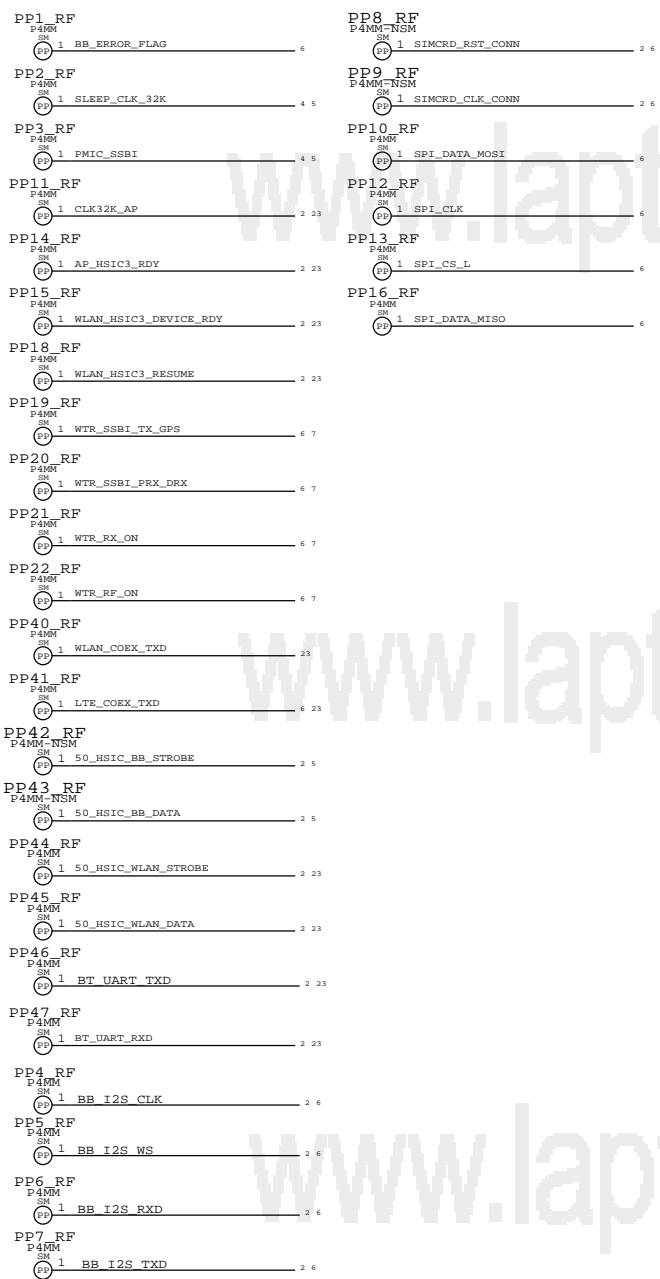

DEBUG CONNECTOR

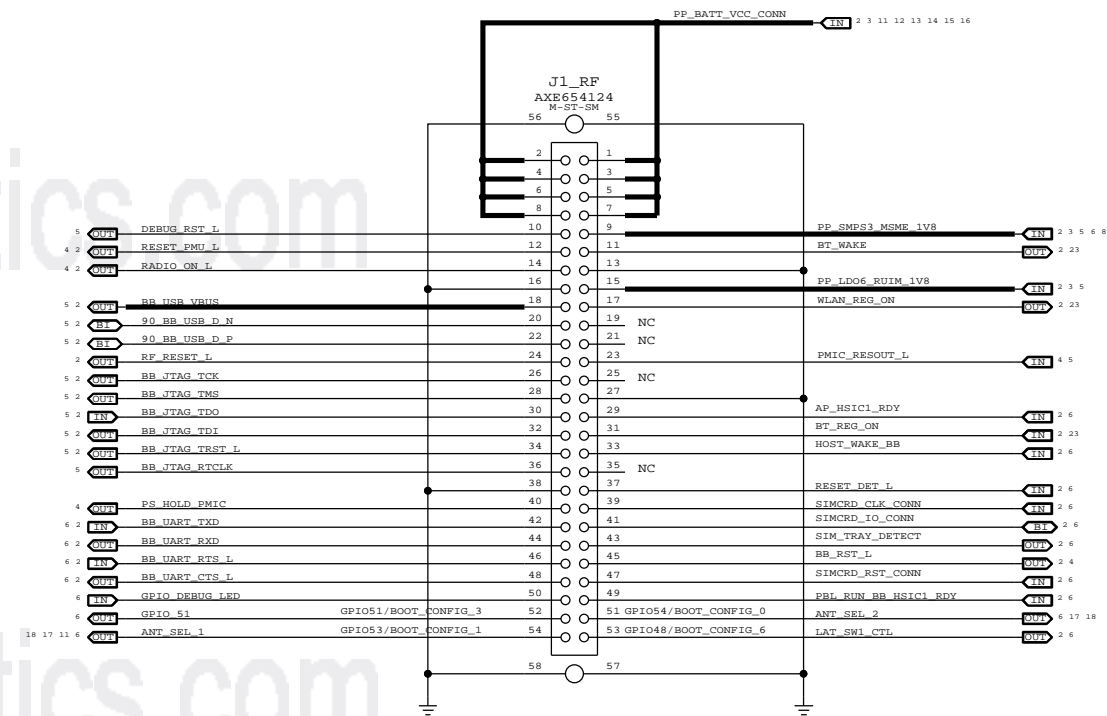

BOOT OPTIONS	BOOT_CONFIG SW REGISTER VALUE	GPIO/BOOT_CONFIG CONFIGURATION								
		6	5	4	3	2	1	0		
BOOT_DEFAULT_OPTION	0x00	X	0	0	0	0	0	0	0	X
BOOT_NAND_OPTION	0x01	X	1	0	0	0	0	0	0	1
BOOT_HSIC_OPTION	0x02	X	1	0	0	0	0	1	0	X
BOOT_USB_OPTION	0x03	X	1	0	0	0	0	1	1	X
ENABLE SAHARA PROTOCOL	0x08	X	1	0	0	1	0	X	X	X

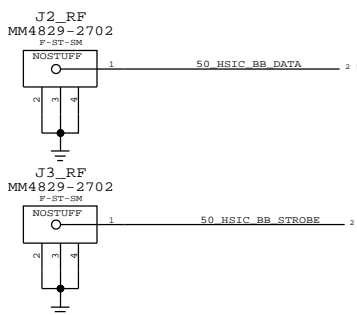

SIM CARD CONNECTOR

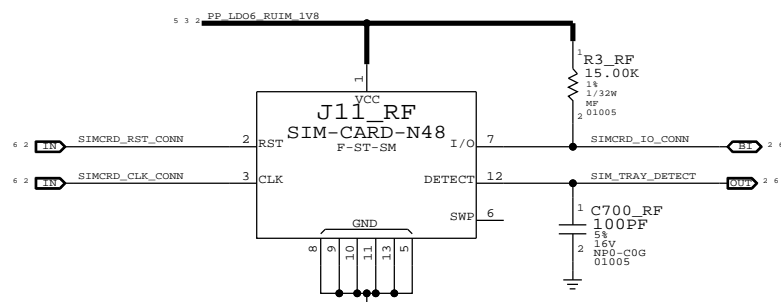

SIM CARD ESD PROTECTION

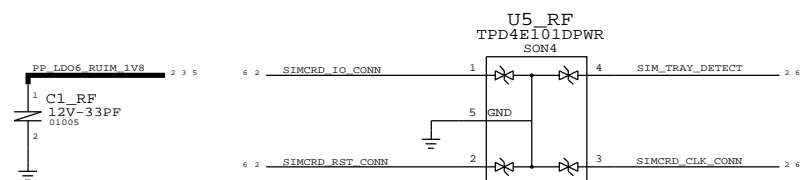

PMU (1 OF 2)

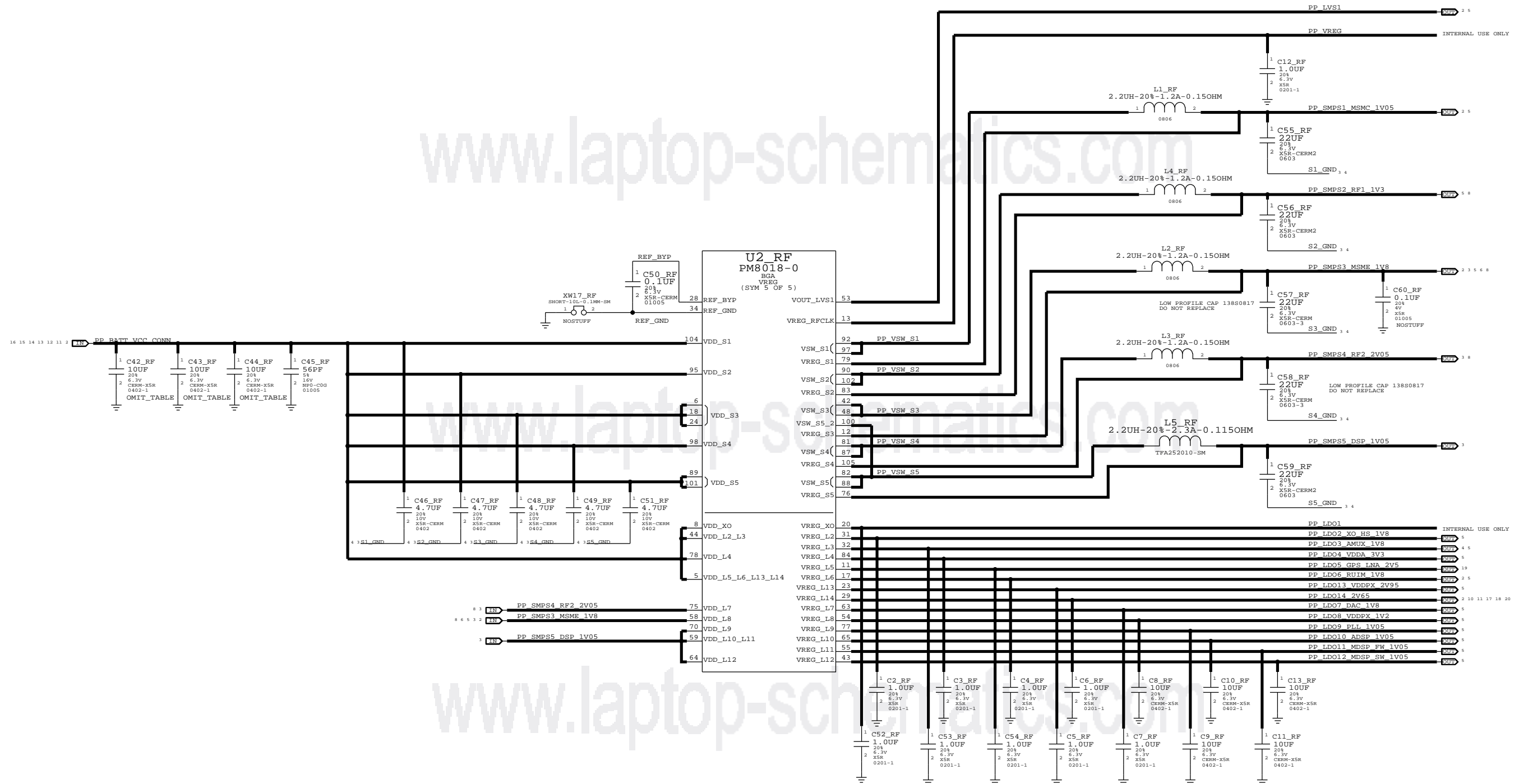

PMU (2 OF 2)

PA_ID	CONFIG	BOARD_ID	REVISION
1.1V	CONFIG A	0.7V	PROTO1
1.3V	CONFIG B	0.9V	PROTO2
1.5V	CONFIG C	1.1V	EVT1
1.7V	CONFIG D	1.3V	EVT2
		1.5V	DVT
		1.7V	PVT

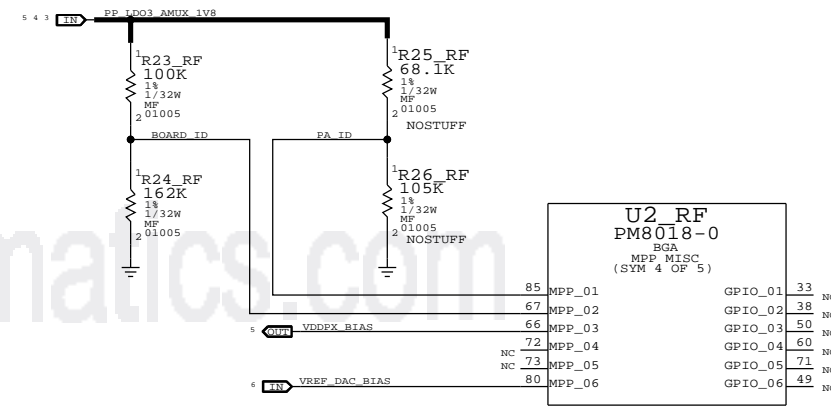

AP SECTION NEEDS ITS OWN THERMISTOR PLACED NEAR THE PA'S.

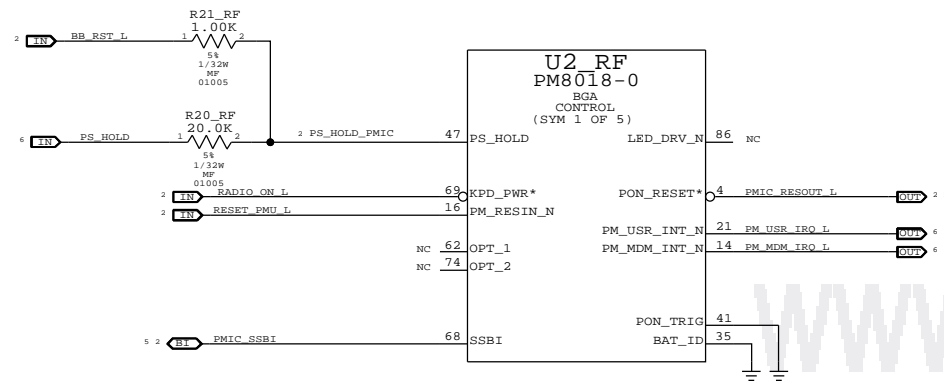

GND NEEDS TO BE CLEARED UNDER THIS CRYSTAL TO MINIMIZE THERMAL DRIFT

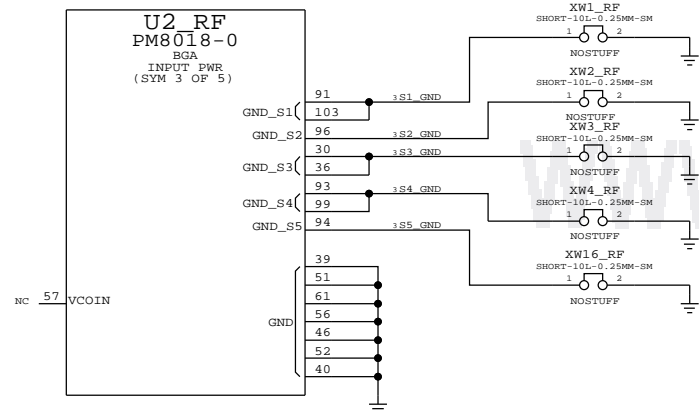
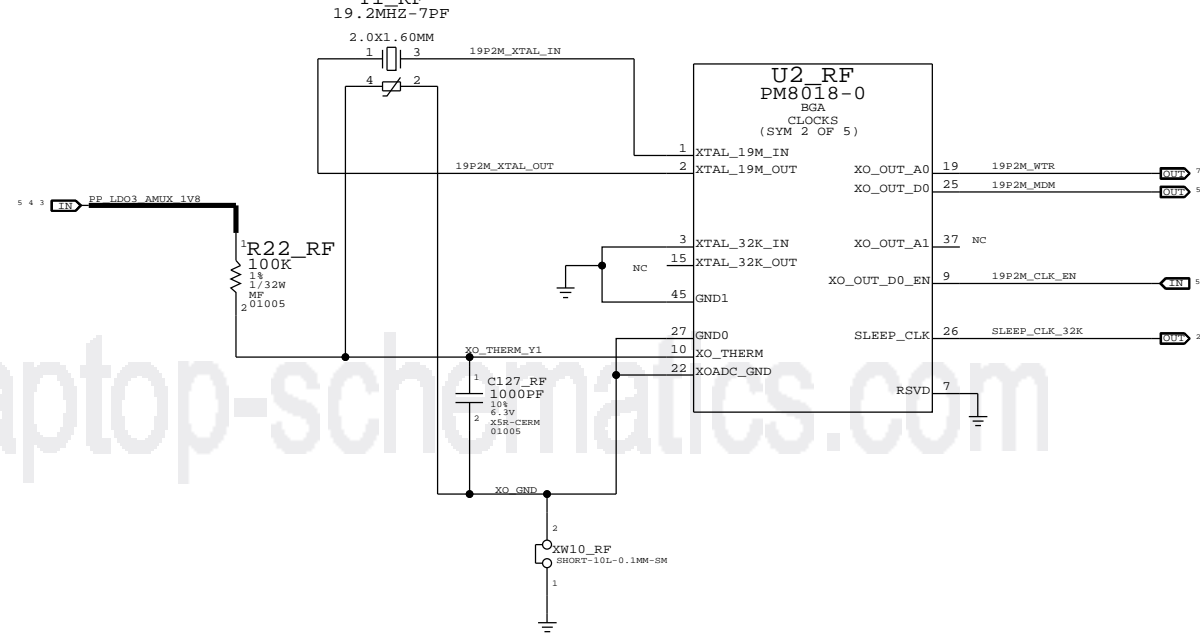

BASEBAND (1 OF 2)

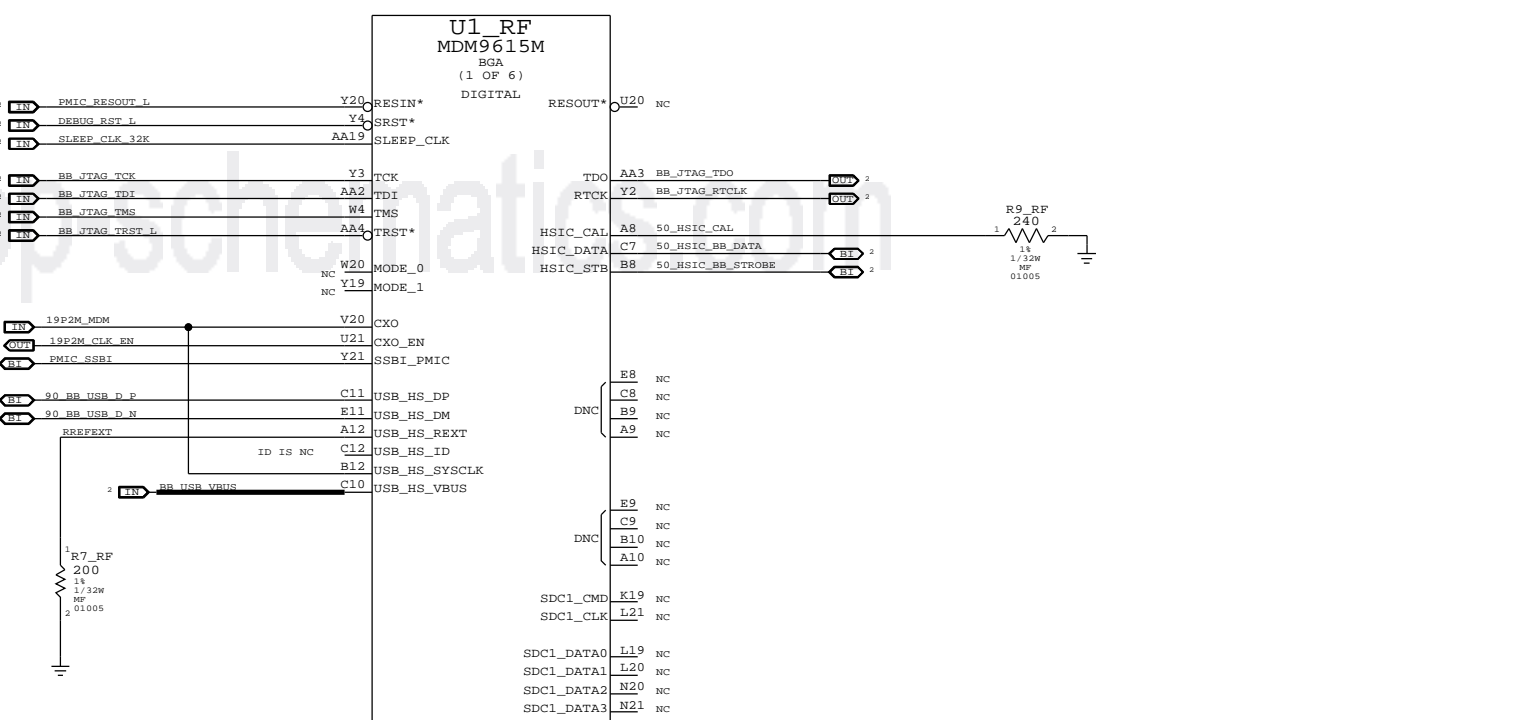
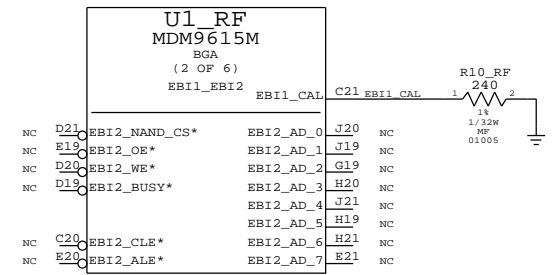
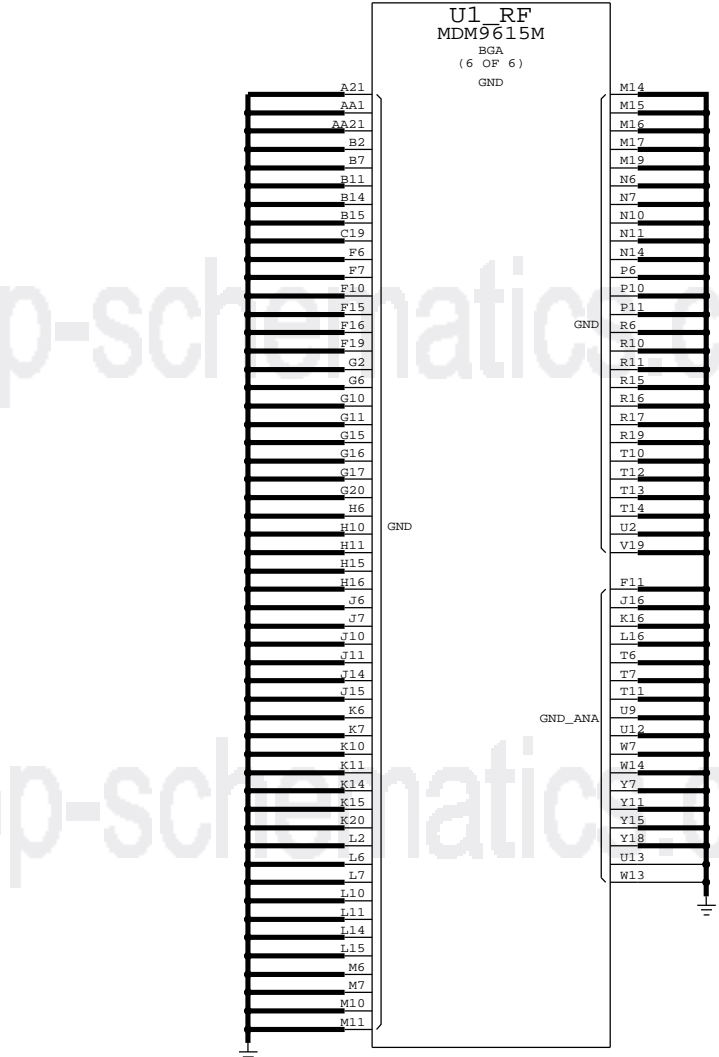
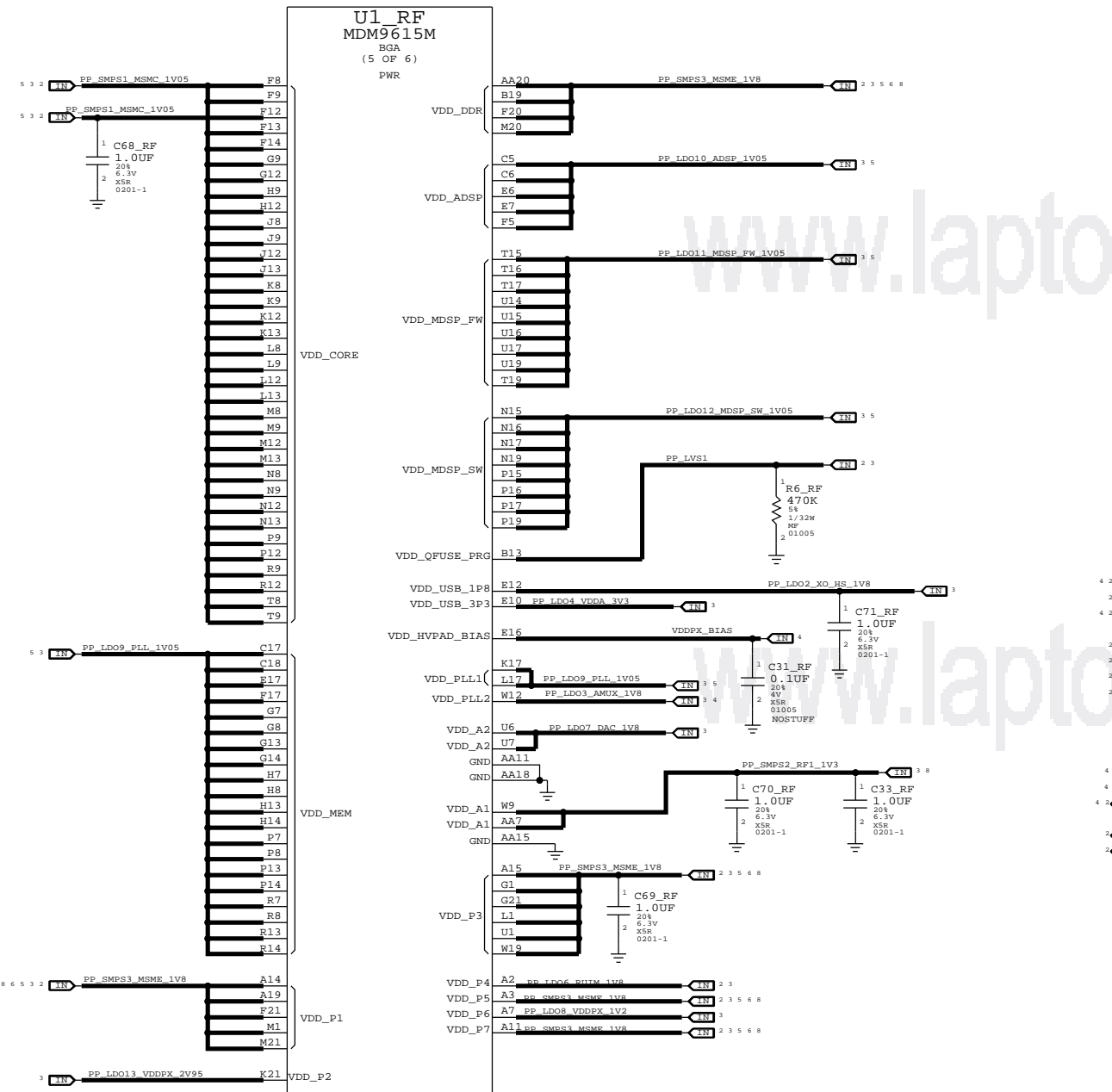
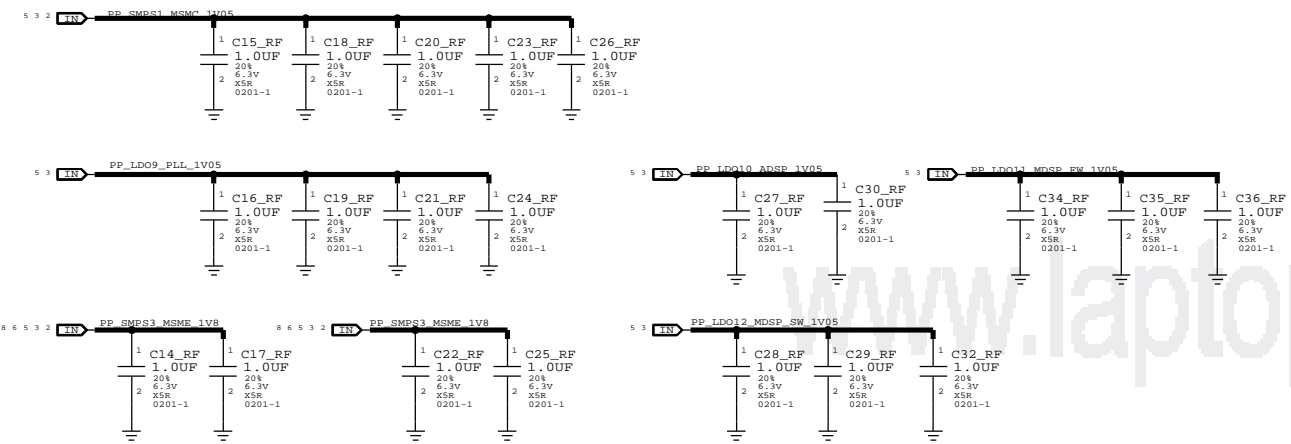

BASEBAND (2 OF 2)

www.laptop-schematics.com

www.laptop-schematics.com

www.laptop-schematics.com

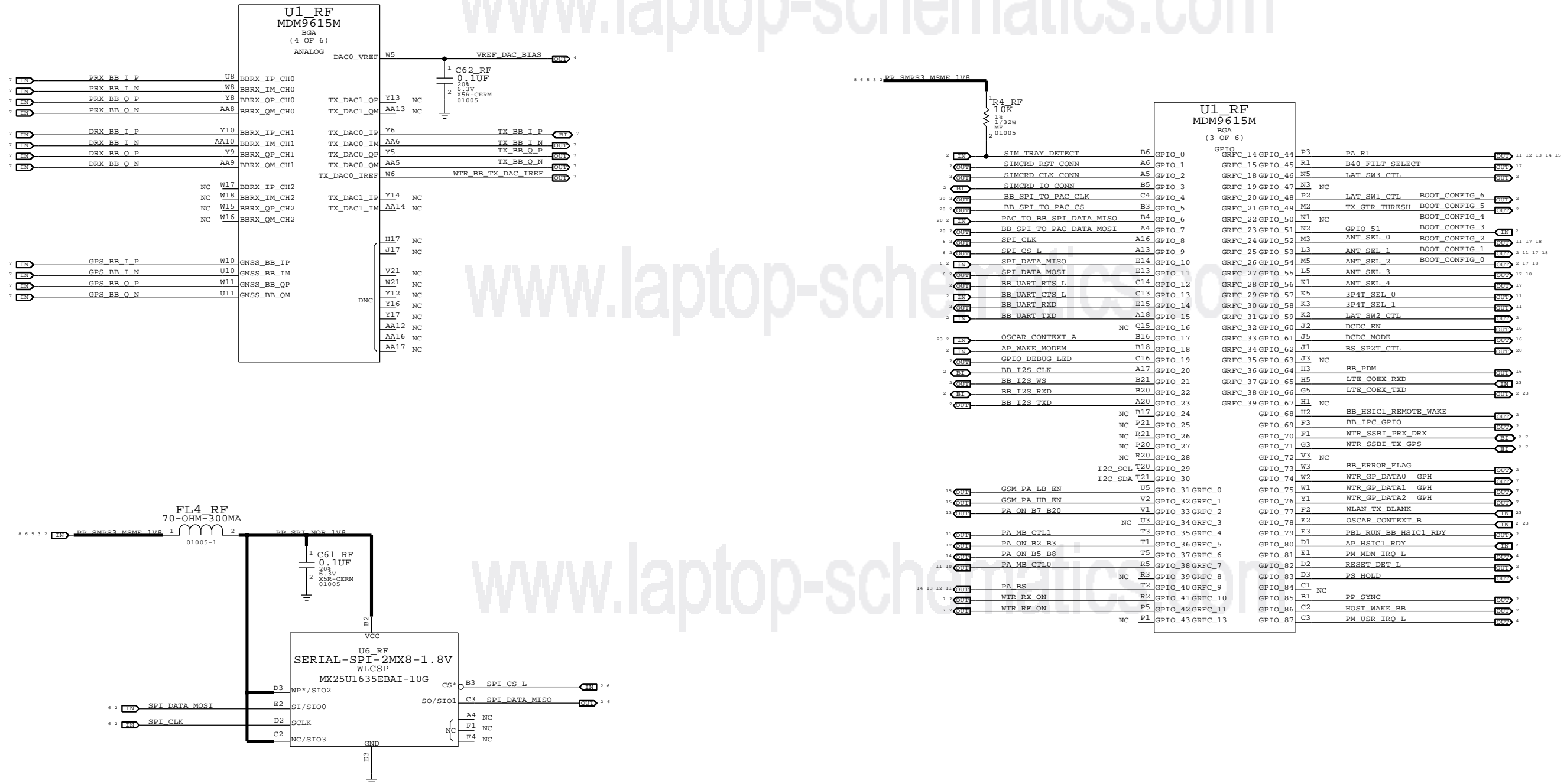

RF TRANSCEIVER (1 OF 2)

PRX TRANSCEIVER RF AND IQ PORTS

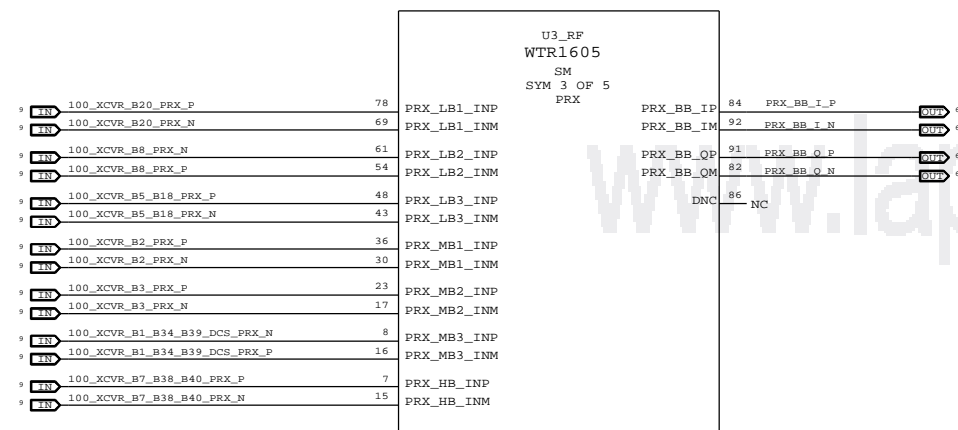

DRX TRANSCEIVER RF AND IQ PORTS

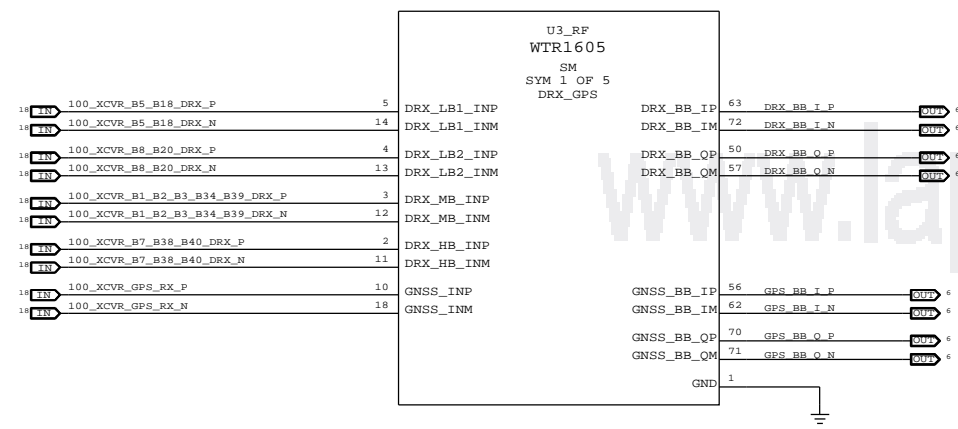

TRANSCEIVER GROUND CONNECTIONS

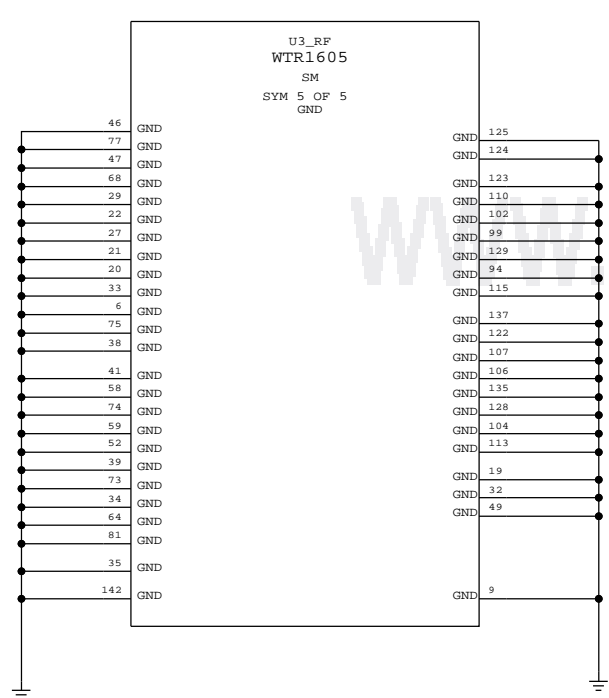

TRANSCEIVER PHASE CONTROL, TX RF & IQ PORTS

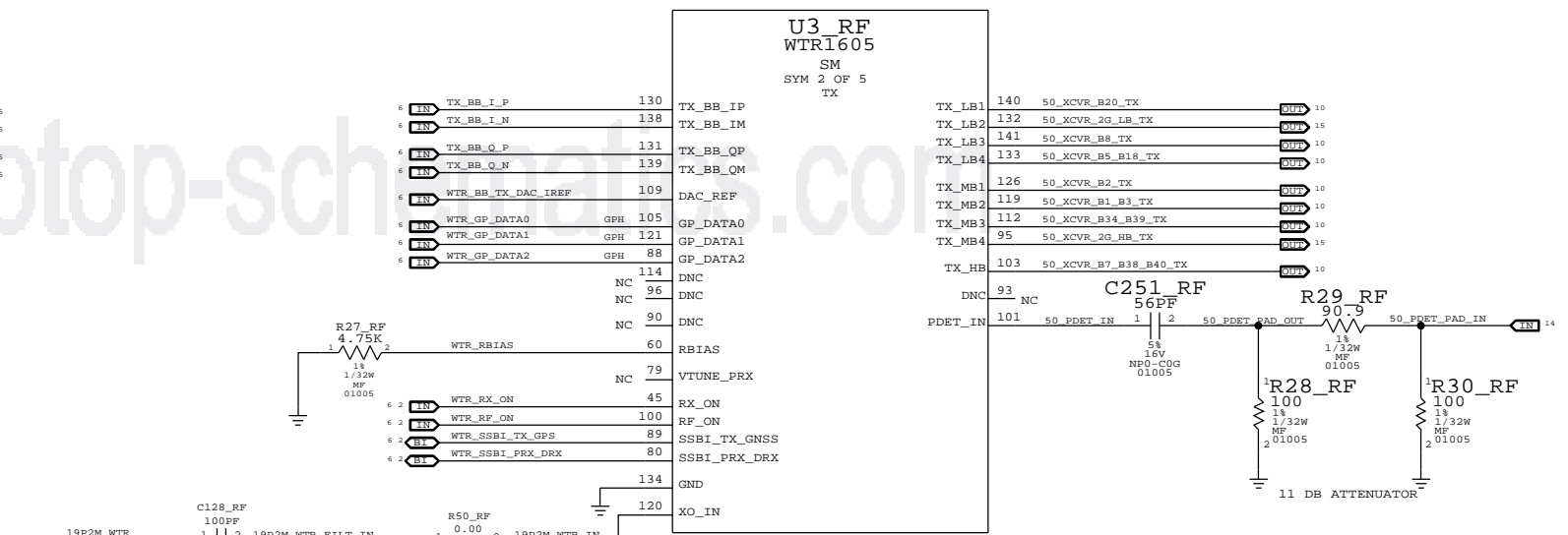

RF TRANSCEIVER (2 OF 2)

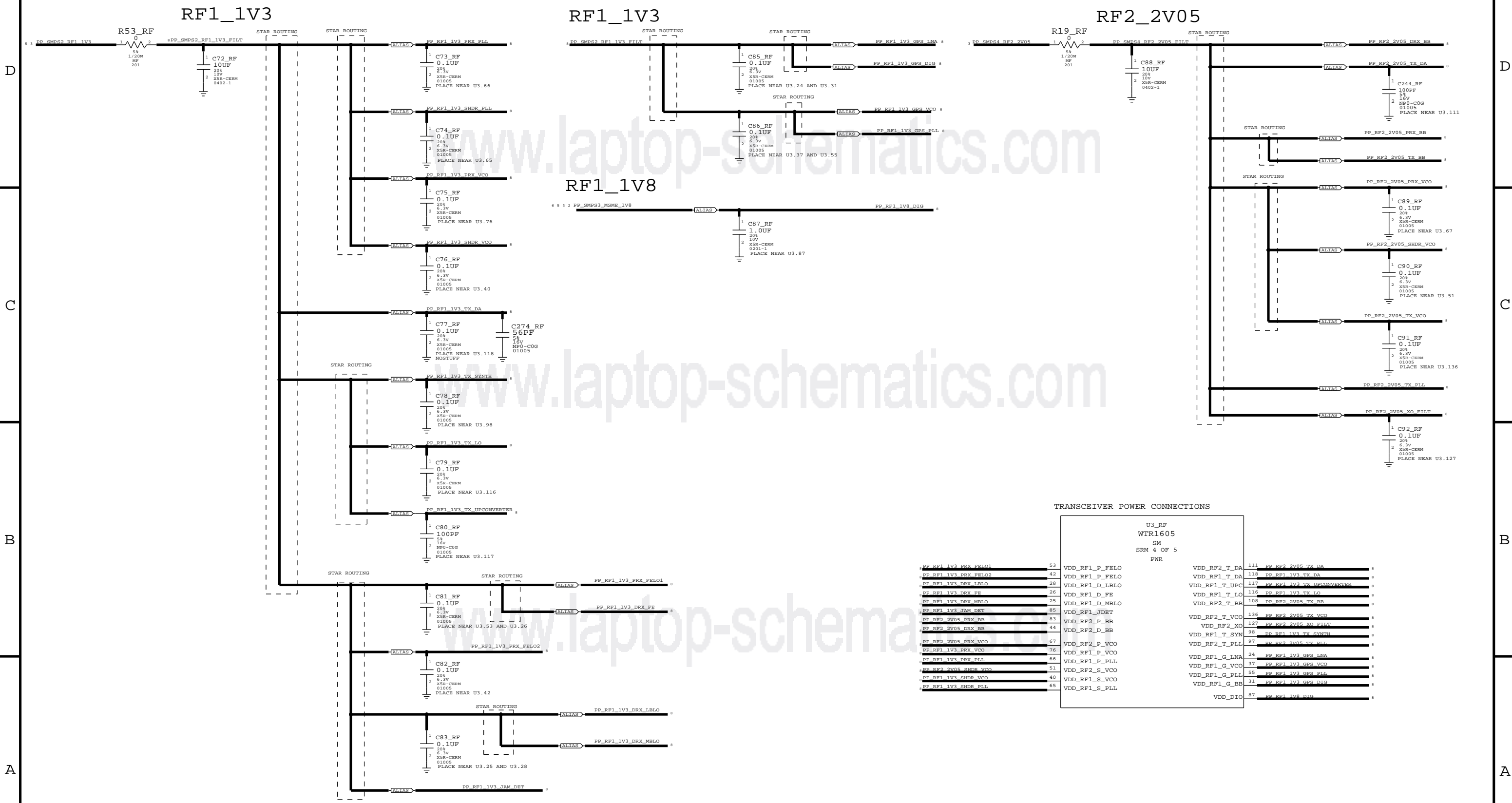

TRANSCEIVER POWER CONNECTIONS

U3_RF		WTR1605		SM		SRM 4 OF 5		PWR	
PP_RF1_1V3_PRX_FEL01	53	VDD_RF1_P_FELO		VDD_RF2_T_DA	111	PP_RF2_2V05_TX_DA			
PP_RF1_1V3_PRX_FEL02	42	VDD_RF1_P_FELO		VDD_RF1_T_DA	118	PP_RF1_1V3_TX_DA			
PP_RF1_1V3_DRX_LBLO	28	VDD_RF1_D_LBLO		VDD_RF1_T_UPC	117	PP_RF1_1V3_TX_UPCONVERTER			
PP_RF1_1V3_DRX_FE	26	VDD_RF1_D_FE		VDD_RF1_T_LO	116	PP_RF1_1V3_TX_LO			
PP_RF1_1V3_DRX_MBLO	25	VDD_RF1_D_MBLO		VDD_RF2_T_BB	108	PP_RF2_2V05_TX_BB			
PP_RF1_1V3_JAM_DET	85	VDD_RF1_JDET		VDD_RF2_T_VCO	136	PP_RF2_2V05_TX_VCO			
PP_RF2_2V05_PRX_BB	83	VDD_RF2_P_BB		VDD_RF2_XO	127	PP_RF2_2V05_XO_FILT			
PP_RF2_2V05_DRX_BB	44	VDD_RF2_D_BB		VDD_RF1_T_SYN	98	PP_RF1_1V3_TX_SYNTH			
PP_RF2_2V05_PRX_VCO	67	VDD_RF2_P_VCO		VDD_RF2_T_PLL	97	PP_RF2_2V05_TX_PLL			
PP_RF1_1V3_PRX_VCO	76	VDD_RF1_P_VCO		VDD_RF1_G_LNA	24	PP_RF1_1V3_GPS_LNA			
PP_RF1_1V3_PRX_PLL	66	VDD_RF1_P_PLL		VDD_RF1_G_VCO	37	PP_RF1_1V3_GPS_VCO			
PP_RF2_2V05_SHDR_VCO	51	VDD_RF2_S_VCO		VDD_RF1_G_VCO	55	PP_RF1_1V3_GPS_PLL			
PP_RF1_1V3_SHDR_VCO	40	VDD_RF1_S_VCO		VDD_RF1_G_PLL	31	PP_RF1_1V3_GPS_DIG			
PP_RF1_1V3_SHDR_PLL	65	VDD_RF1_S_PLL		VDD_DIO	87	PP_RF1_1V8_DIG			

TX INTERSTAGE FILTERS

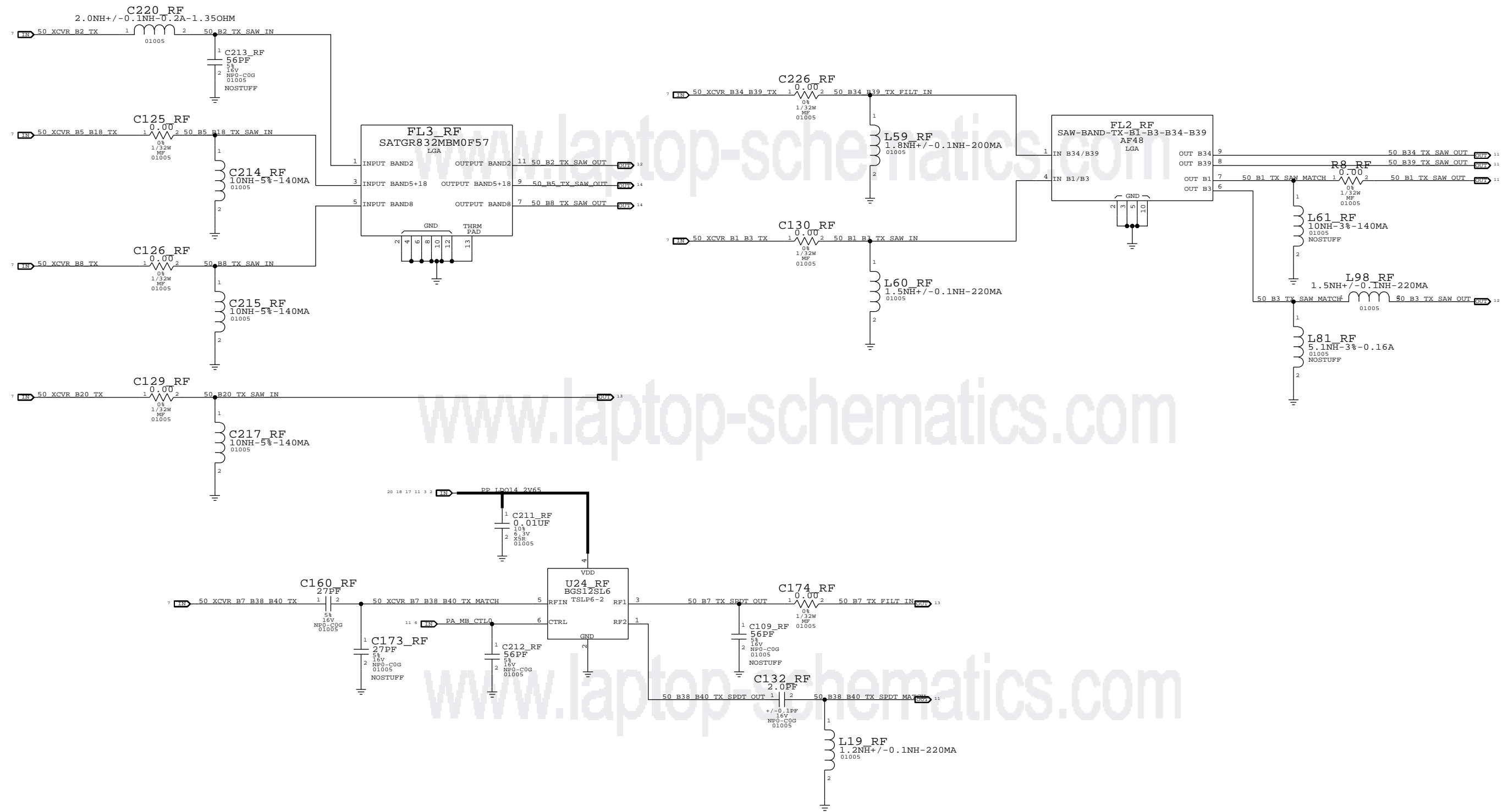

BAND 1/34/39/38/40 TX

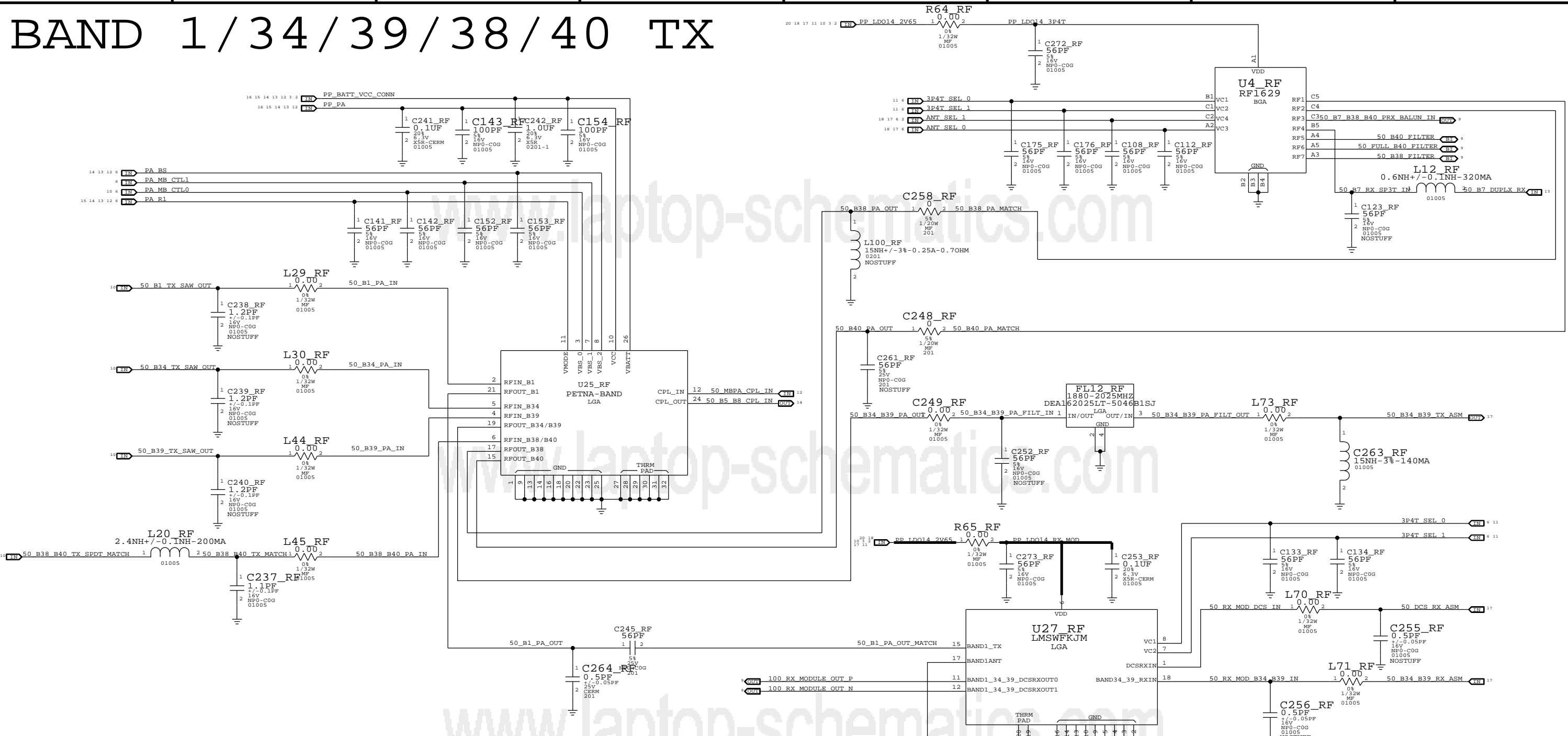

BAND	PA	POWER	MODE	PA_BS	PA_CTL1	PA_CTL0	PA_R1
OFF		X		X	0	0	0
B1	HPM			X	1	0	0
B1	LPM			X	1	0	1
B34	HPM			1	0	1	0
B34	LPM			1	0	1	1
B39	HPM			0	0	1	0
B39	LPM			0	0	1	1
B38	HPM			1	1	1	0
B38	LPM			1	1	1	1
B40	HPM			0	1	1	0
B40	LPM			0	1	1	1

BAND 2/3 PAD

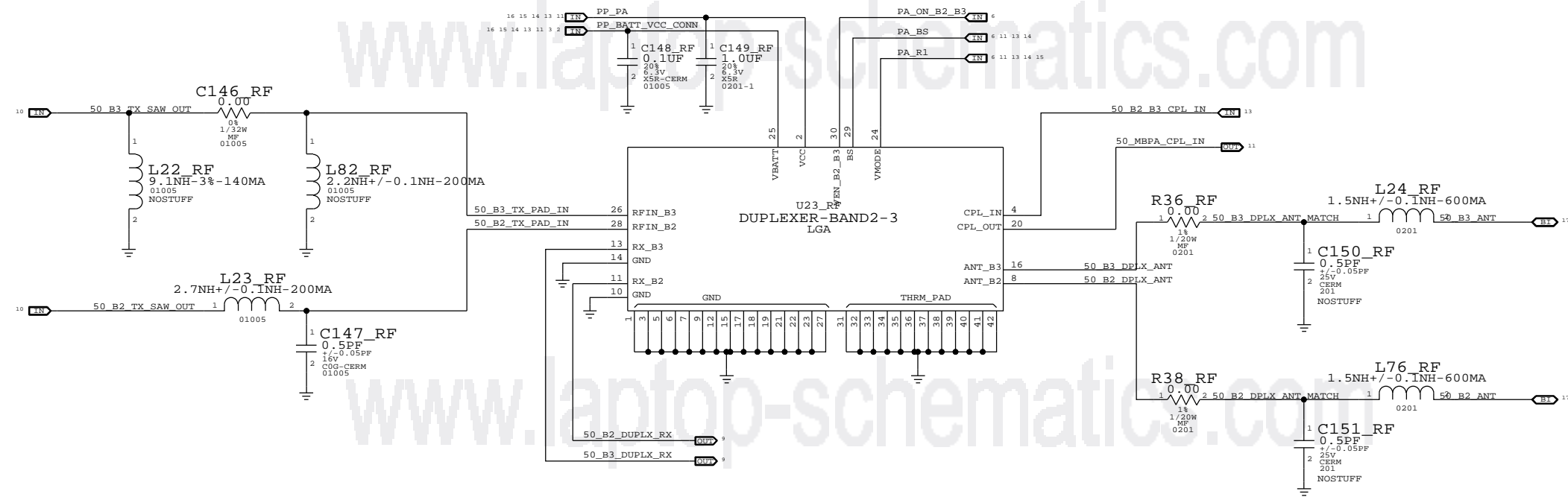

BAND	PA POWER MODE	PA_BS	PA_ON_B2_B3	PA_R1
OFF	X	X	0	X
B3	HPM	0	1	0
B3	LPM	0	1	1
B2	HPM	1	1	0
B2	LPM	1	1	1

BAND 20/7 PAD

www.laptop-schematics.com

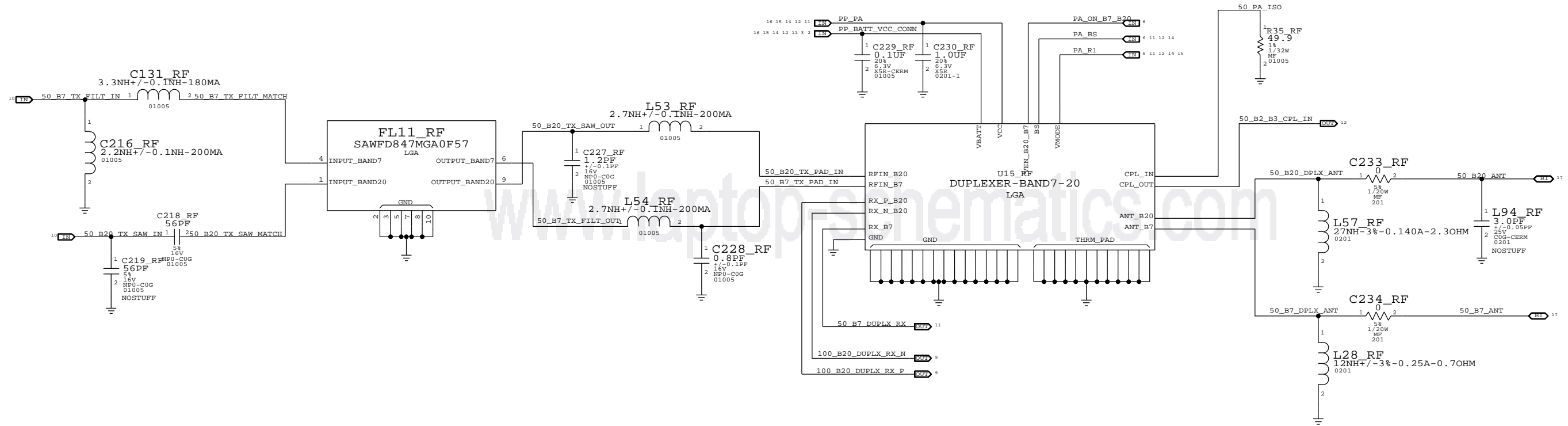

BAND	PA	POWER	MODE	PA_BS	PA_ON_B20_B7	PA_R1
OFF		X		X	0	X
B20		HPM		0	1	0
B20		LPM		0	1	1
B7		HPM		1	1	0
B7		LPM		1	1	1

BAND 5 / 8 PAD

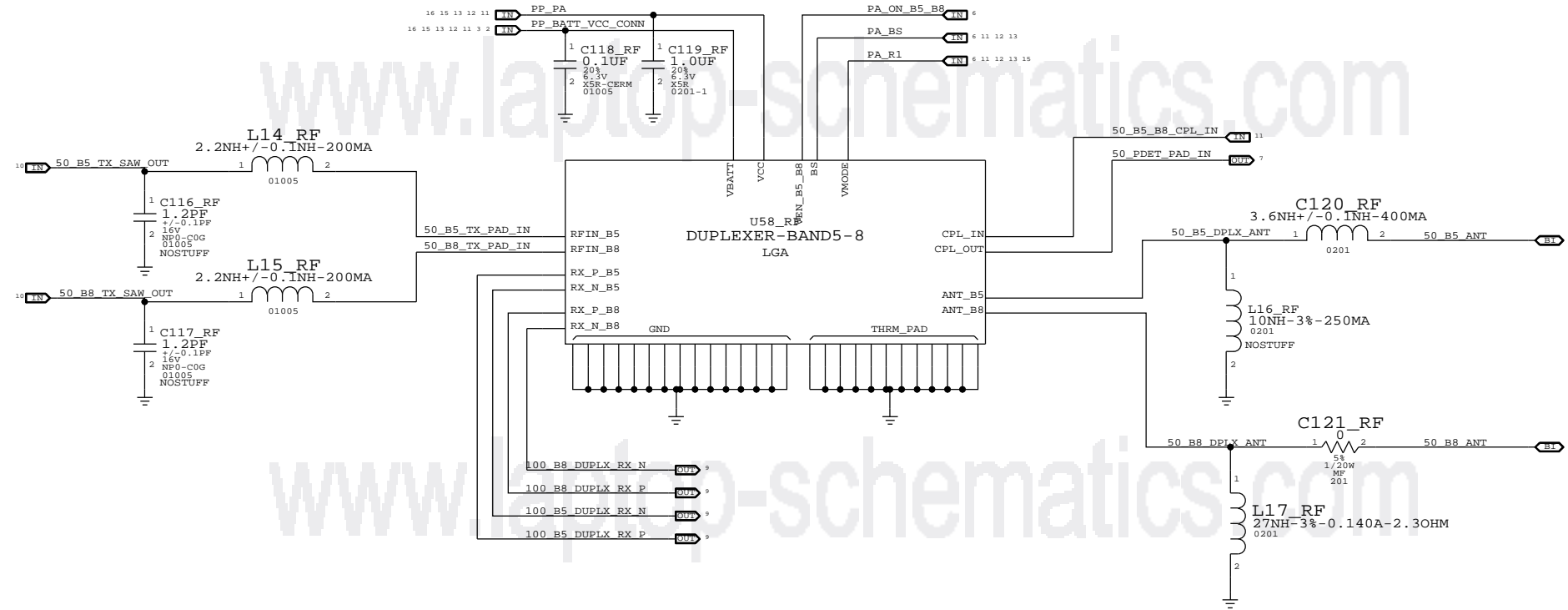

BAND	PA POWER MODE	PA_BS	PA_ON_B5_B8	PA_R1
OFF	X	X	0	X
B5	HPM	0	1	0
B5	LPM	0	1	1
B8	HPM	1	1	0
B8	LPM	1	1	1

2G PA

CONFIDENTIAL AND PROPRIETARY APPLE SYSTEM DESIGN. FOR REFERENCE PURPOSES ONLY - NOT A CHANGE REQUEST.

2G PA GAIN MODES

BAND	MODE	GAIN MODE	PA_R1	PCL RANGE
LOW BAND	GSM	ULTRA LOW	HIGH	16 TO 19
LOW BAND	GSM	LOW	HIGH	14 TO 15
LOW BAND	GSM	MEDIUM	LOW	7 TO 13
LOW BAND	GSM	HIGH	LOW	5 TO 6
HIGH BAND	GSM	ULTRA LOW	HIGH	10 TO 15
HIGH BAND	GSM	LOW	HIGH	7 TO 9
HIGH BAND	GSM	HIGH	LOW	0 TO 6
LOW BAND	EDGE	LOW	HIGH	15 TO 19
LOW BAND	EDGE	MEDIUM	LOW	10 TO 14
LOW BAND	EDGE	HIGH	LOW	8 TO 9
HIGH BAND	EDGE	LOW	HIGH	9 TO 15
HIGH BAND	EDGE	HIGH	LOW	2 TO 8

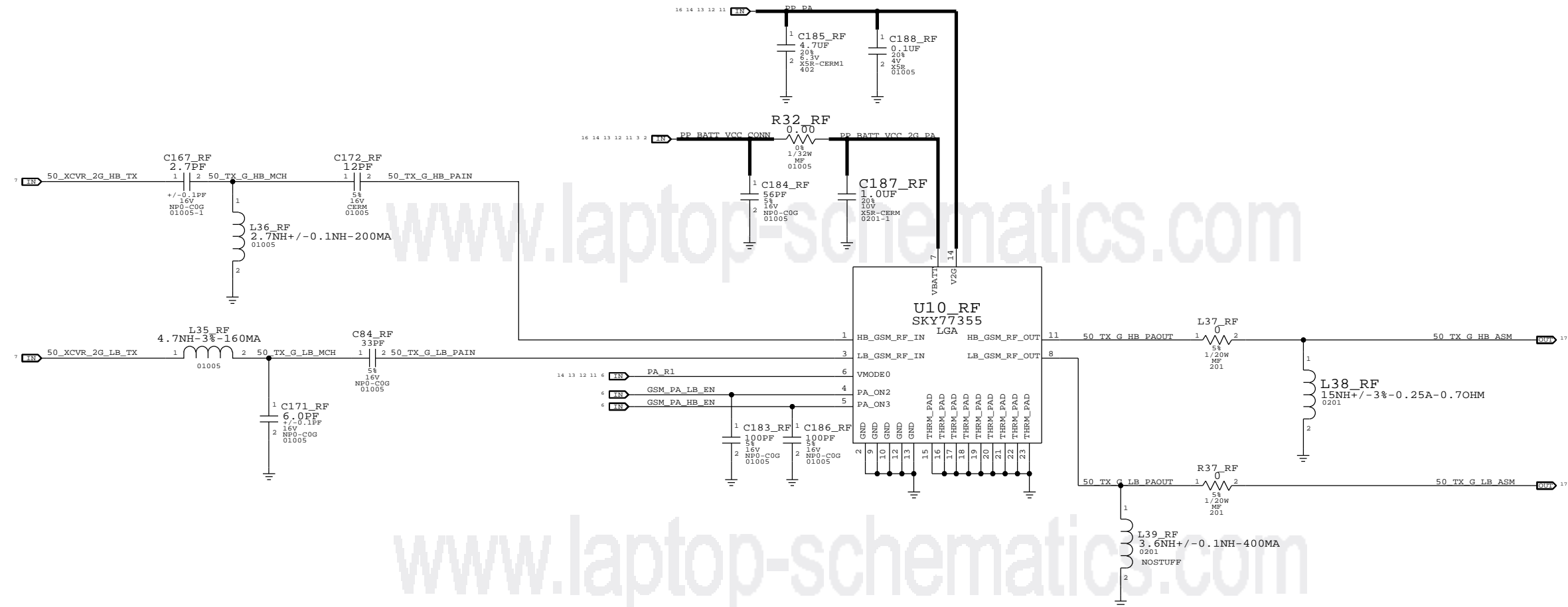

www.laptop-schematics.com

www.laptop-schematics.com

www.laptop-schematics.com

PA DC/DC CONVERTER

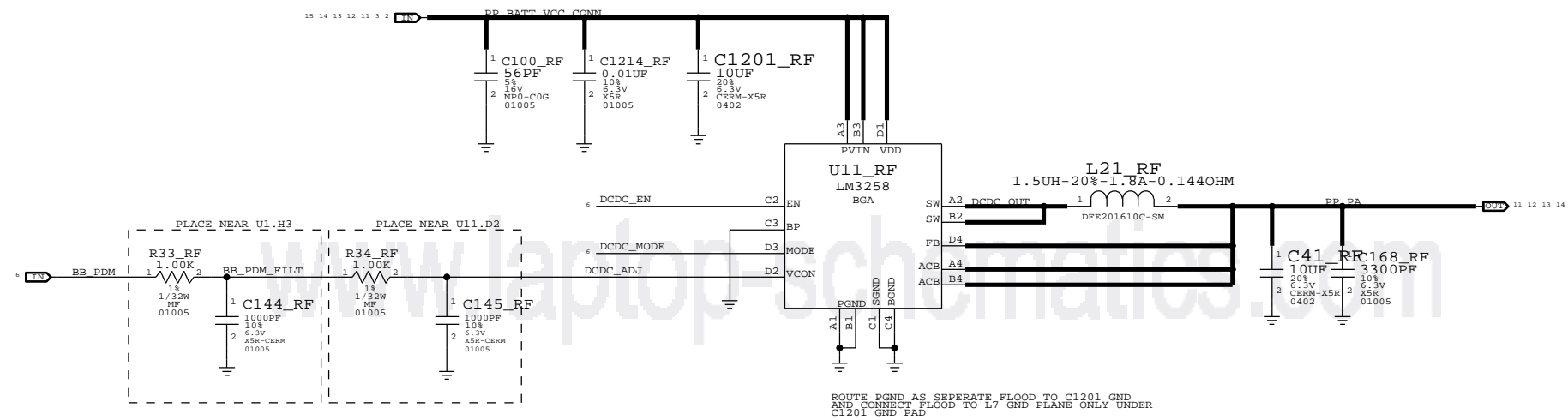

PRIMARY ASM

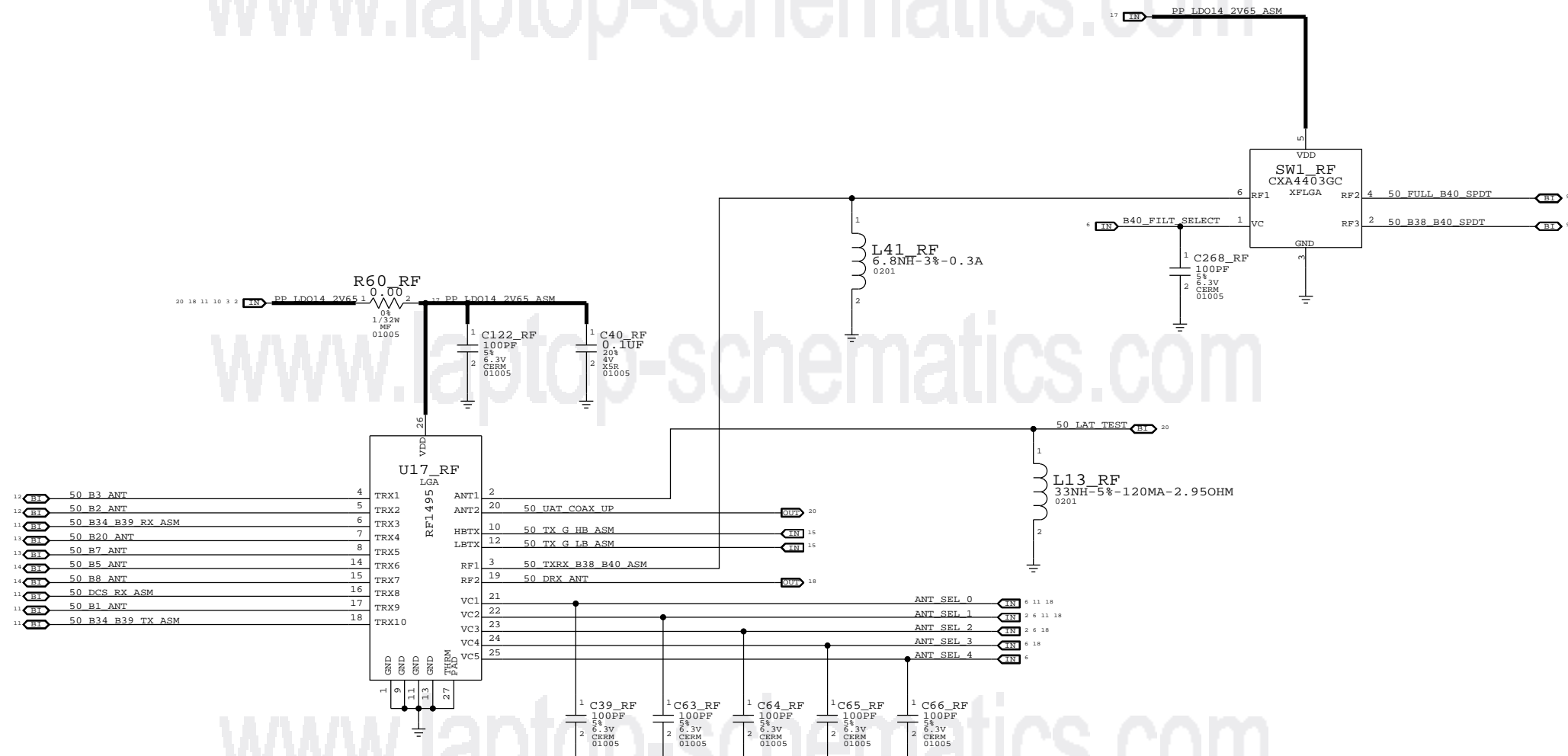

RX DIVERSITY

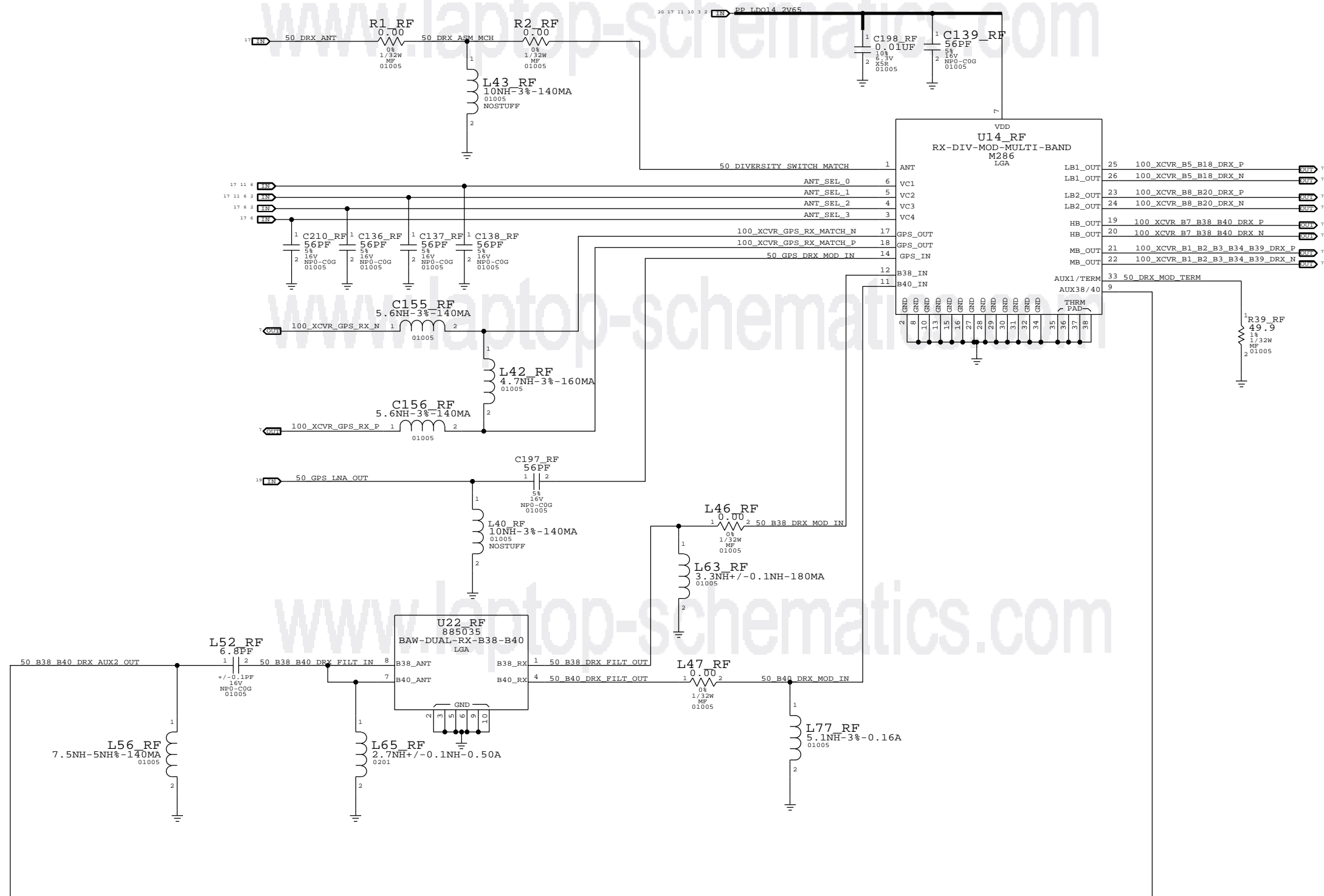

GPS

www.laptop-schematics.com

www.laptop-schematics.com

www.laptop-schematics.com

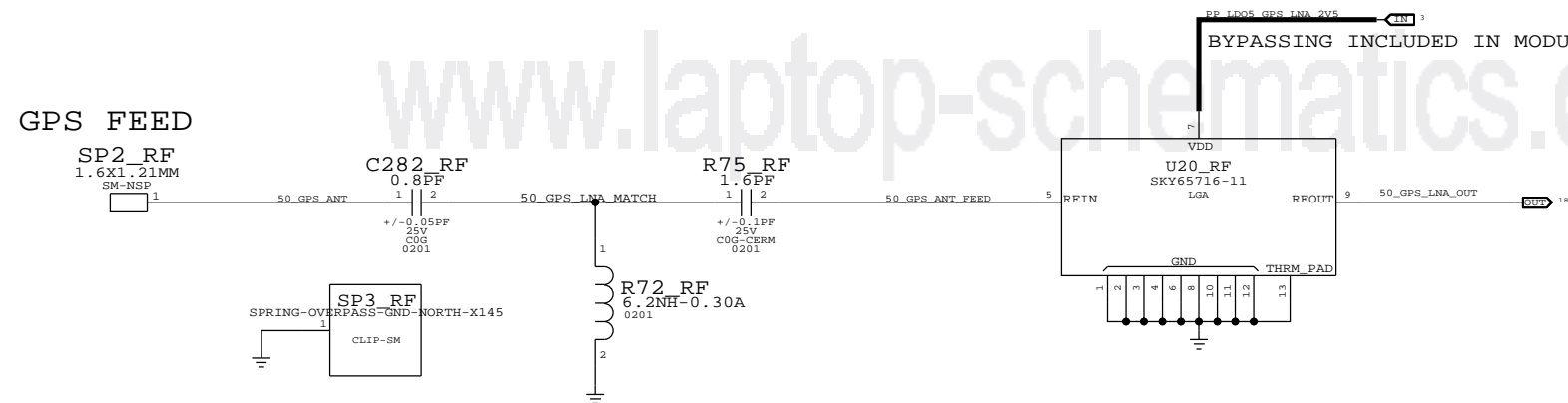

ANTENNA FEEDS

UAT1

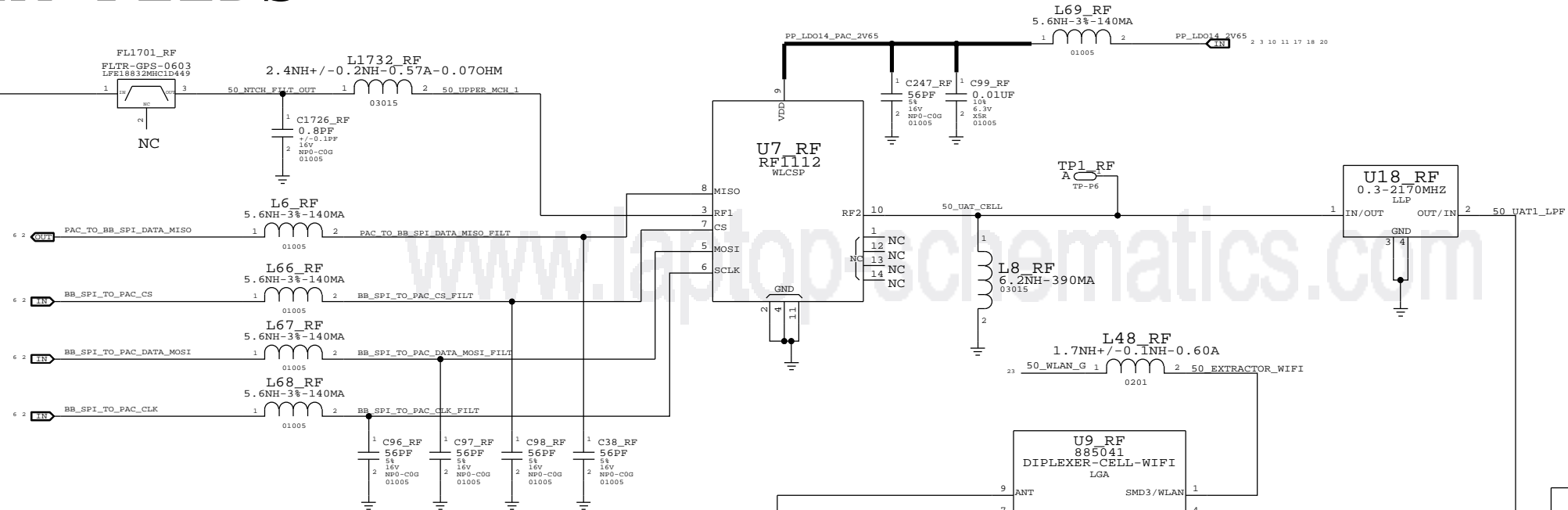

UAT2

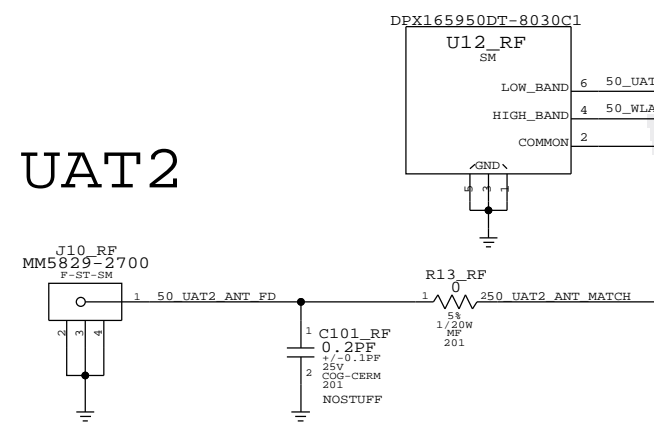

UAT1 COAX

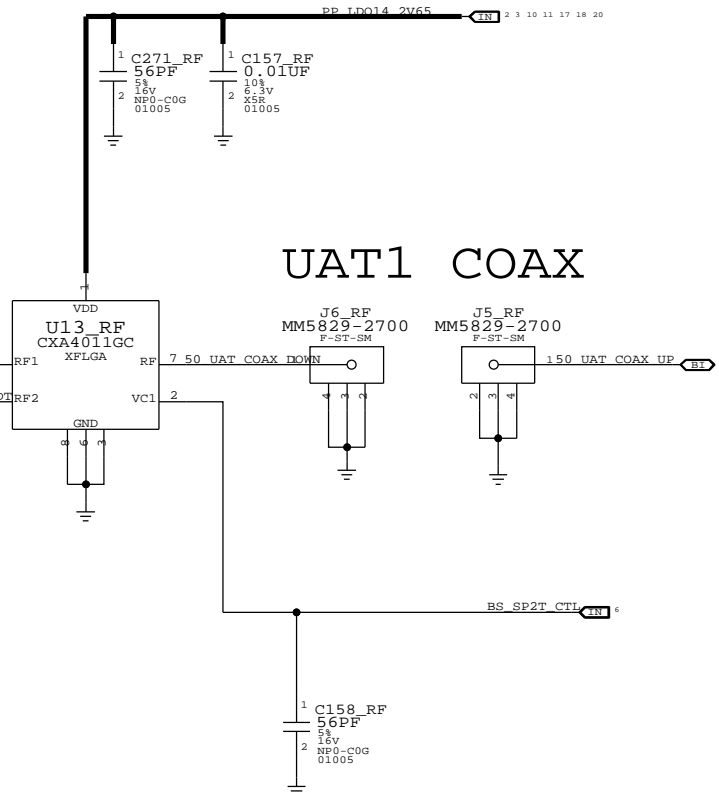

LAT

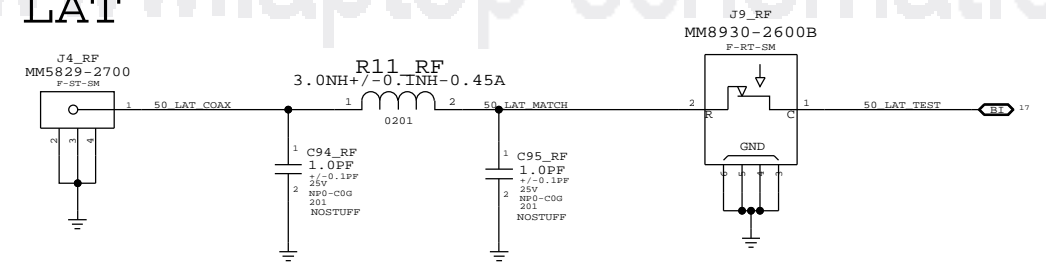

WLAN/ BT

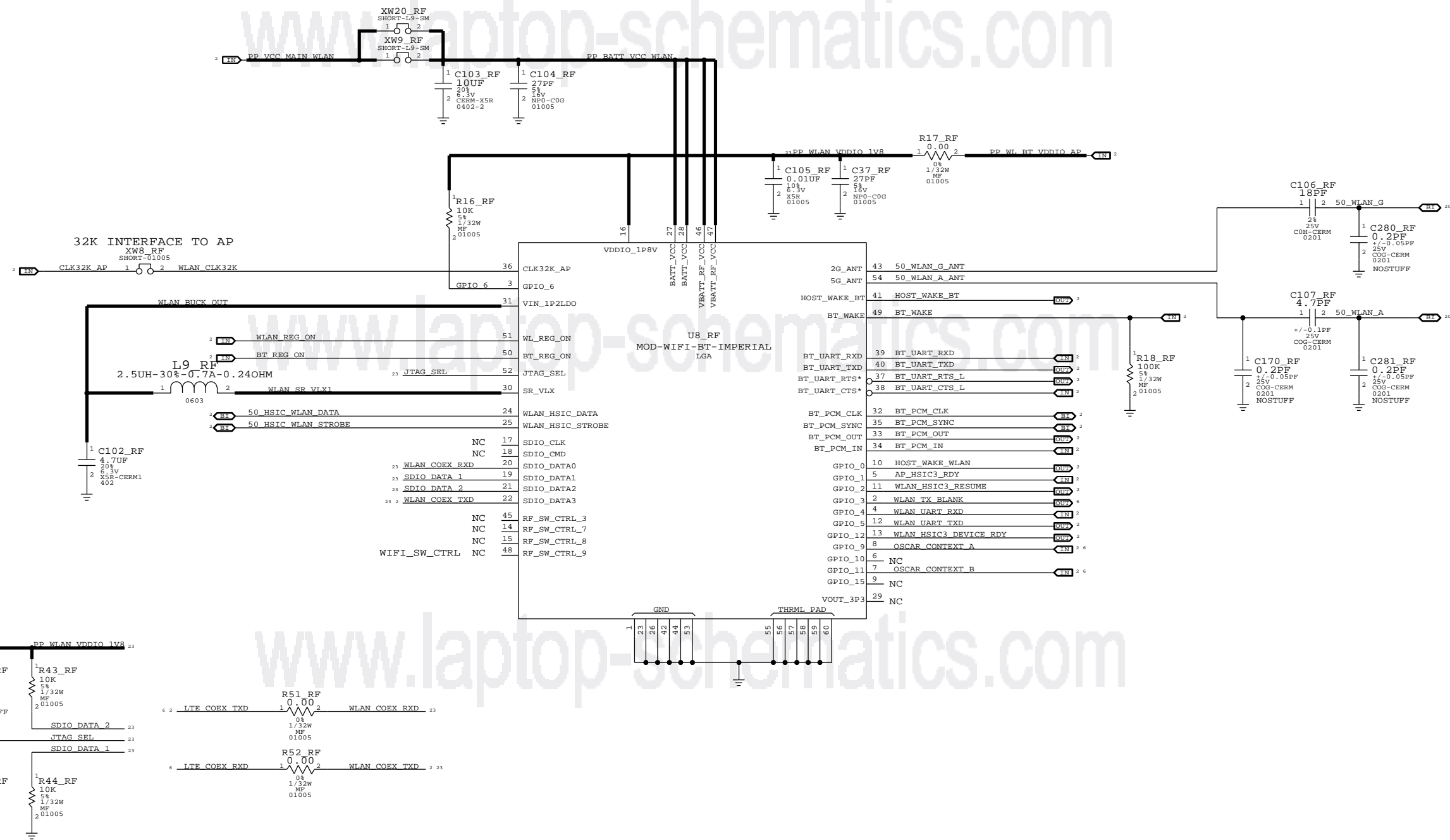

PULL-UP ON GPIO6, SDIO_DATA_2 & PULL-DOWN ON SDIO_DATA_1 REQUIRED FOR HSIC BOOTSTRAPPING