

4

3

2

1

REV	EDD#	DESCRIPTION OF REVISION

NOTES: (UNLESS OTHERWISE SPECIFIED)

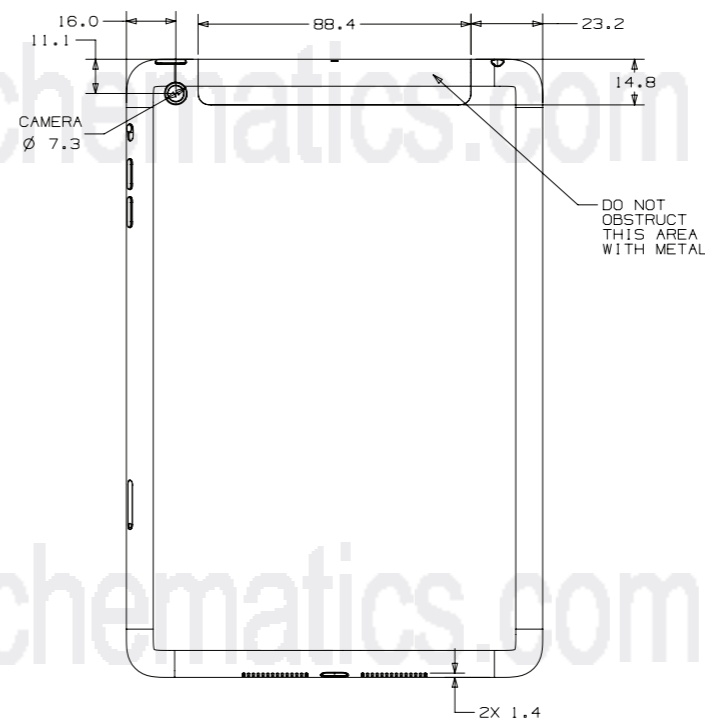
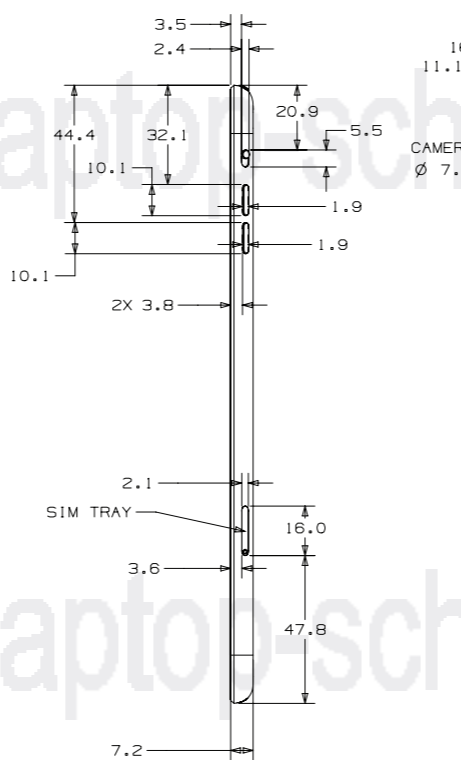
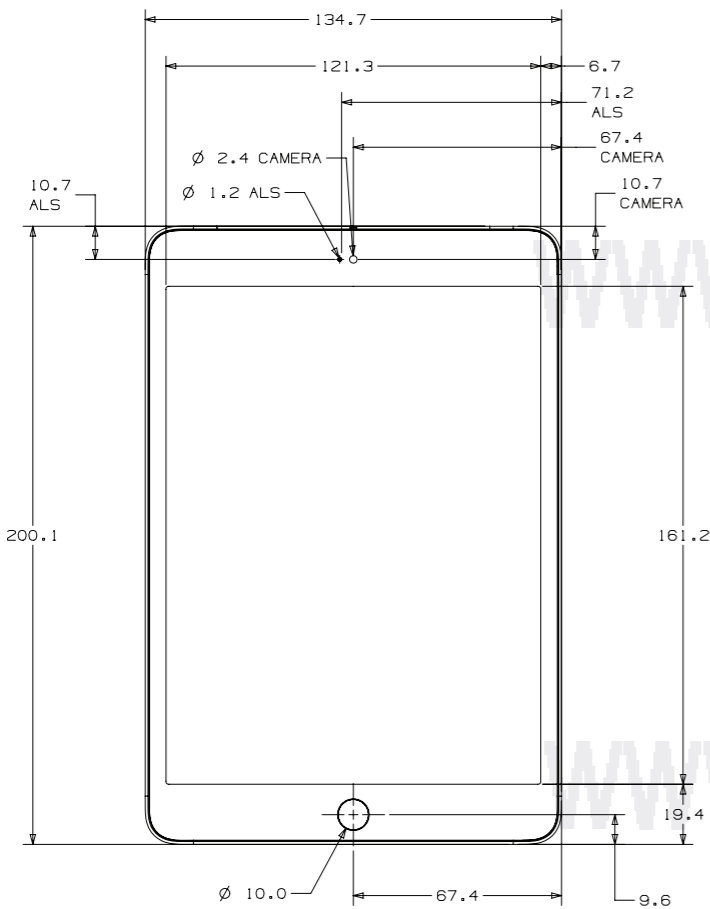
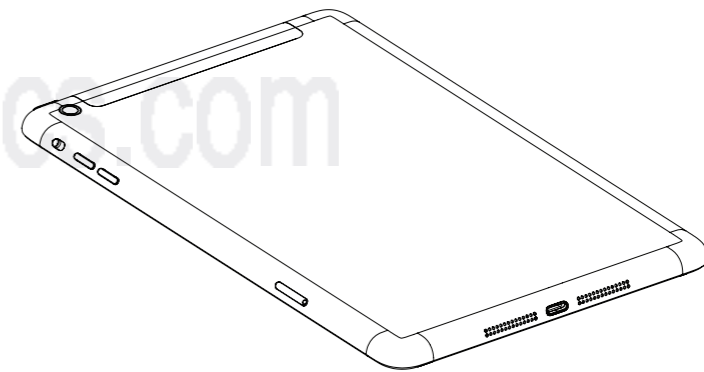
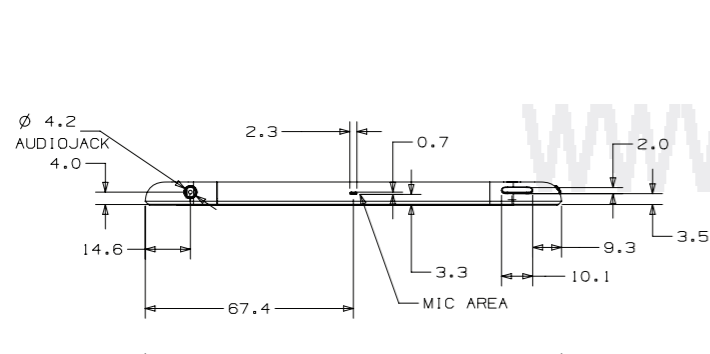

DO NOT OBSTRUCT THIS AREA WITH METAL

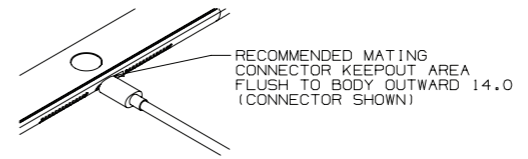
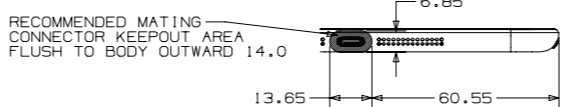
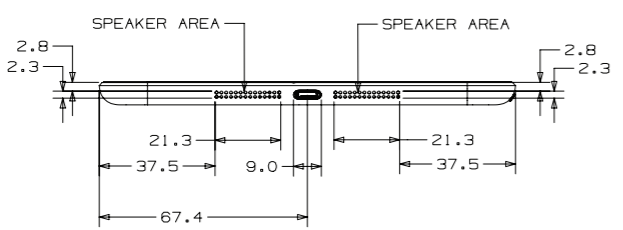

METRIC		Apple Inc.	
DRAWER APPLE INC.	DATE	NOTICE OF PROPRIETARY PROPERTY: THE INFORMATION CONTAINED HEREIN IS THE PROPRIETARY PROPERTY OF APPLE INC. THE POSSESSOR AGREES TO MAINTAIN THIS DOCUMENT IN CONFIDENCE (1) NOT TO REPRODUCE OR COPY IT (2) NOT TO RENTAL OR PUBLISH IT IN WHOLE OR PART (3) ALL RIGHTS RESERVED	
DESIGNER APPLE INC.	DATE	TITLE IPAD MINI WITH WI-FI + 4G	
DIMENSIONS ARE IN MILLIMETERS		DRAWING NUMBER	
TOLERANCES		REV.	
X.X	±0.2		
X.XX	±0.10		
X.XXX	±0.050		
ANGLES	±0.5°		
DO NOT SCALE DRAWINGS			
THIRD ANGLE PROJECTION	SIZE D	SCALE NONE	SHT 1 OF 1



1. ALL RESISTANCE VALUES ARE IN OHMS, 0.1 WATT +/- 5%.  
 2. ALL CAPACITANCE VALUES ARE IN MICROFARADS.  
 3. ALL CRYSTALS & OSCILLATOR VALUES ARE IN HERTZ.

REV	ECN	DESCRIPTION OF REVISION	CK APPD	DATE
13	0001520462	ENGINEERING RELEASED		2012-07-02

# X123 MAIN LOGIC BOARD

DVT  
 LAST\_MODIFIED=Wed Jun 27 16:39:53 2012

SCH AND BOARD PART NUMBERS

PART#	QTY	DESCRIPTION	REFERENCE DESIGNATOR(S)	BOM OPTION
051-9374	1	SCH,MLB,X123	SCH1	
820-3243	1	PCB,MLB,X123	PCB1	

www.laptop-schematics.com

PDF	CSA	CONTENTS	SYNC MASTER	DATE
1	1	TABLE OF CONTENTS	N/A	N/A
2	2	BLOCK DIAGRAM: SYSTEM	N/A	N/A
3	6	AP: MAIN	N/A	04/18/2011
4	7	AP: I/Os	N/A	05/05/2011
5	8	AP: FLASH MEMORY INTERFACE	N/A	04/18/2011
6	9	AP: TV/DP/MIPI/CAMERA	MLB	05/04/2012
7	10	AP: PWR	N/A	04/18/2011
8	11	AP: PWR	N/A	04/18/2011
9	12	AP: MISC & ALIASES	N/A	04/11/2011
10	13	E75 SUPPORT	N/A	N/A
11	14	NAND STORAGE	MLB	05/04/2012
12	17	TOUCH: FLEX CONNECTOR	N/A	06/21/2010
13	18	AUDIO JACK FLEX CONN	N/A	03/31/2011
14	19	AUDIO: L81 CODEC	KAVITHA	01/18/2012
15	20	AUDIO: CS35L19A AMPS	KAVITHA	01/18/2012
16	22	VIDEO: MIPI CONNECTOR	N/A	N/A
17	26	FF CAM & MIC CONNECTORS	N/A	N/A
18	27	INERTIAL SENSORS	N/A	N/A
19	28	PROX SENSOR	N/A	N/A
20	29	BUTTON & REAR CAMERA CONN	N/A	N/A

PDF	CSA	CONTENTS	SYNC MASTER	DATE
21	31	SYSTEM & DEBUG CONNECTORS	JORGE	06/27/2012
22	32	BASEBAND PMU (1 OF 2)	JORGE	06/27/2012
23	33	BASEBAND PMU (2 OF 2)	JORGE	06/27/2012
24	34	BASEBAND (1 OF 2)	JORGE	06/27/2012
25	35	MOBILE DATA MODEM (2 OF 2)	JORGE	06/27/2012
26	36	RF TRANSCEIVER (1 OF 3)	JORGE	06/27/2012
27	37	RF TRANSCEIVER (2 OF 3)	JORGE	06/27/2012
28	38	RF TRANSCEIVER (3 OF 3)	JORGE	06/27/2012
29	39	BAND 5/8 PAD	JORGE	06/27/2012
30	40	BAND 13 PA	JORGE	06/27/2012
31	41	2G PA, DCDC CONVERTER	JORGE	06/27/2012
32	42	DCS RX, ASM	JORGE	06/27/2012
33	43	BAND 1/4 PAD	JORGE	06/27/2012
34	44	BAND2 PAD	JORGE	06/27/2012
35	45	RX DIVERSITY	JORGE	06/27/2012
36	46	GPS	JORGE	06/27/2012
37	47	WIFI/BT	JORGE	06/27/2012
38	57	IO FLEX: DOCK COMPONENTS	N/A	04/18/2011
39	73	Power: Aliases	N/A	N/A
40	75	POWER: BATTERY CONNECTOR	N/A	N/A
41	81	Power: PMU	N/A	N/A
42	82	POWER: PMU	N/A	05/09/2011
43	93	MECHANICAL PARTS	N/A	N/A
44	100	CONSTRAINTS: ASSIGNMENTS	N/A	N/A
45	101	CONSTRAINTS: ASSIGNMENTS	N/A	N/A
46	102	CONSTRAINTS: MLB RULES	N/A	N/A

www.laptop-schematics.com

www.laptop-schematics.com

DRAWING TITLE		SCH,MLB,X123	
Apple Inc.	DRAWING NUMBER	051-9374	SIZE
	REVISION	13.0.0	D
NOTICE OF PROPRIETARY PROPERTY:		BRANCH	
THE INFORMATION CONTAINED HEREIN IS THE PROPRIETARY PROPERTY OF APPLE INC. THE POSSESSOR AGREES TO THE FOLLOWING:		PAGE	
I TO MAINTAIN THIS DOCUMENT IN CONFIDENCE		1 OF 102	
II NOT TO REPRODUCE OR COPY IT		SHEET	
III NOT TO REVEAL OR PUBLISH IT IN WHOLE OR PART		1 OF 46	
IV ALL RIGHTS RESERVED			

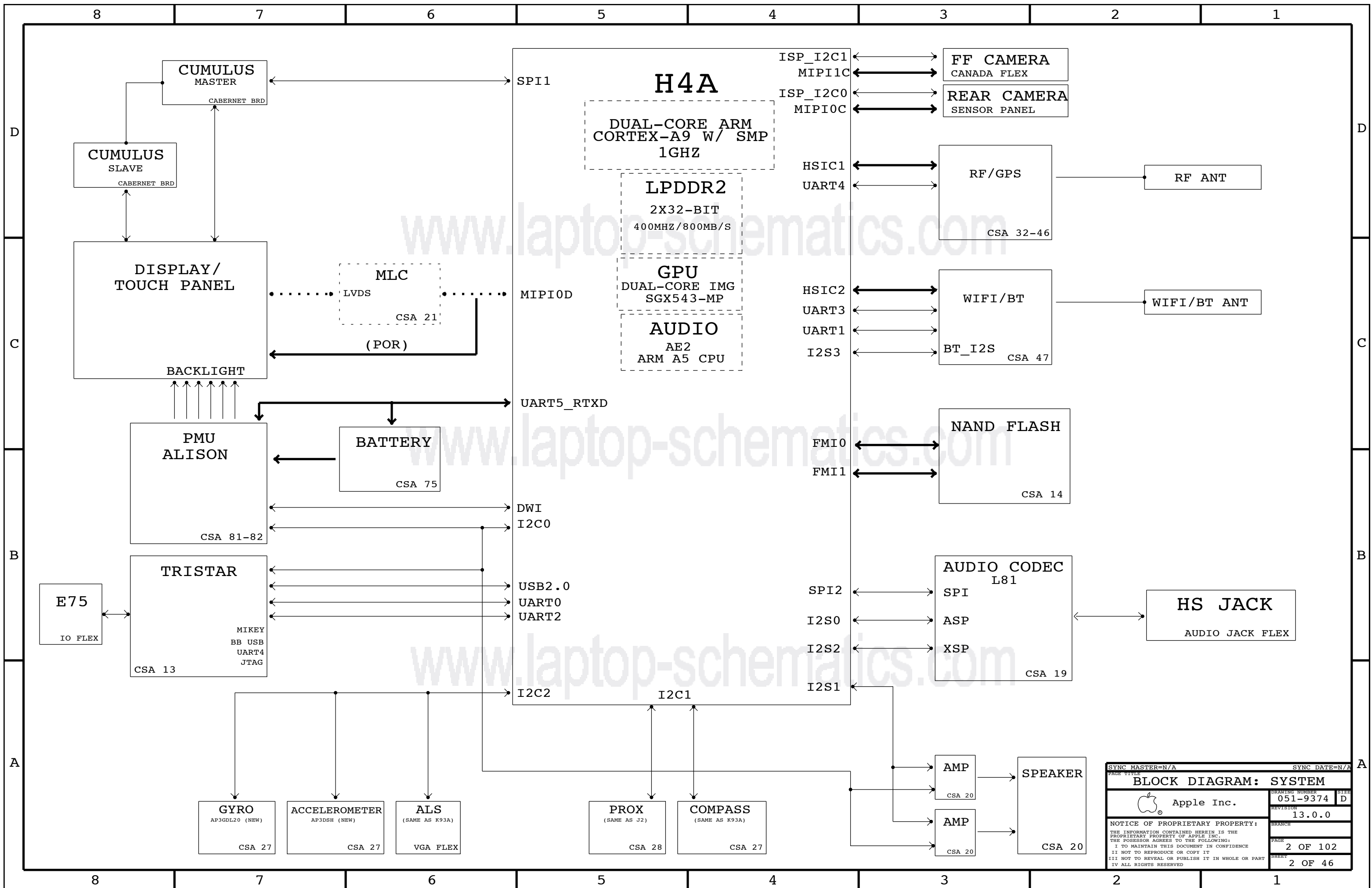

SYNC MASTER=N/A		SYNC DATE=N/A	
<b>BLOCK DIAGRAM: SYSTEM</b>			
Apple Inc.		DRAWING NUMBER	SIZE
		051-9374	D
		REVISION	
		13.0.0	
NOTICE OF PROPRIETARY PROPERTY: THE INFORMATION CONTAINED HEREIN IS THE PROPRIETARY PROPERTY OF APPLE INC. THE POSSESSOR AGREES TO THE FOLLOWING: I TO MAINTAIN THIS DOCUMENT IN CONFIDENCE II NOT TO REPRODUCE OR COPY IT III NOT TO REVEAL OR PUBLISH IT IN WHOLE OR PART IV ALL RIGHTS RESERVED		BRANCH	
		PAGE	2 OF 102
		SHEET	2 OF 46

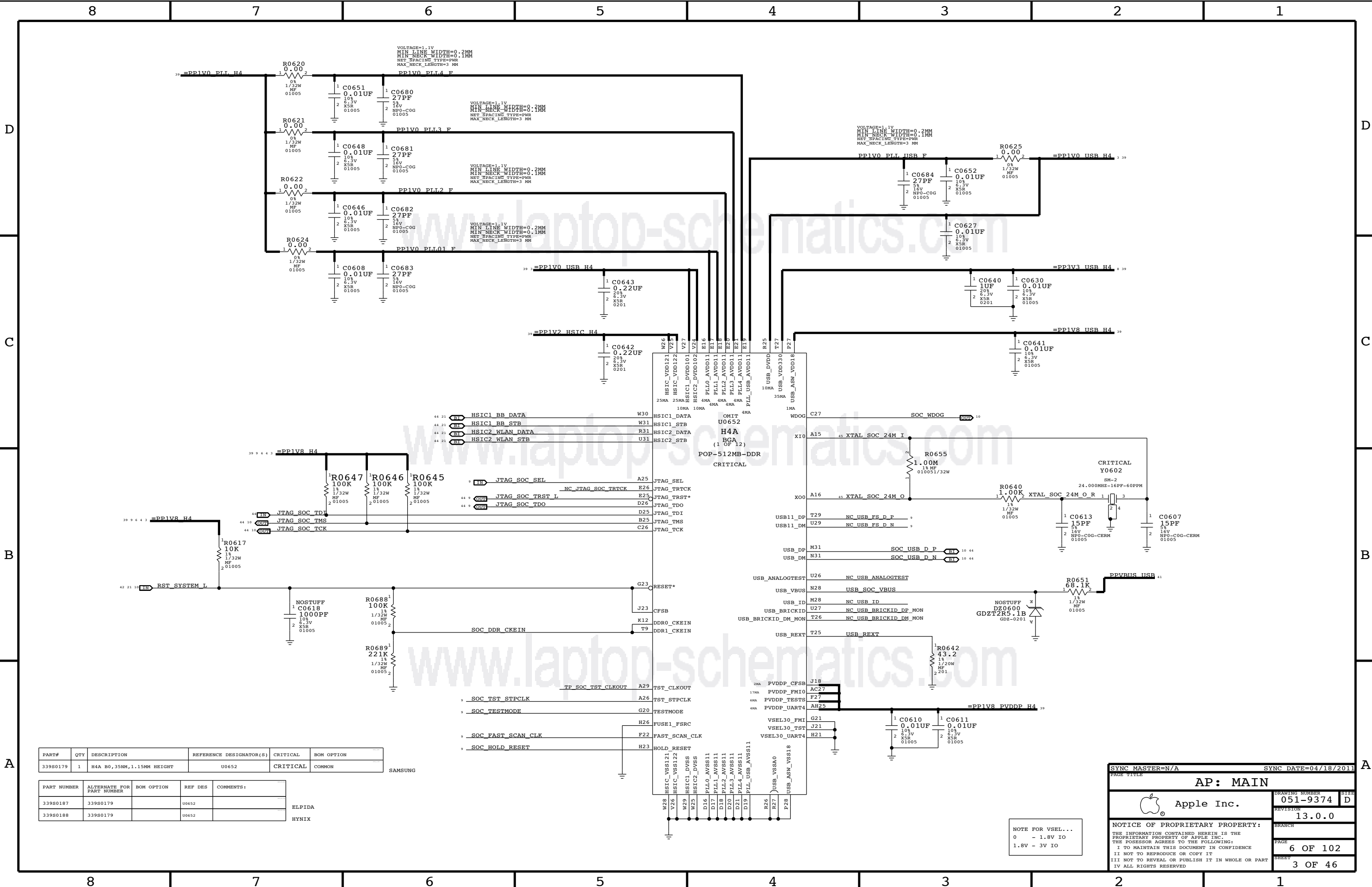

PART#	QTY	DESCRIPTION	REFERENCE DESIGNATOR(S)	CRITICAL	BOM OPTION
33980179	1	H4A B0, 35NM, 1.15MM HEIGHT	U0652	CRITICAL	COMMON

PART NUMBER	ALTERNATE FOR PART NUMBER	BOM OPTION	REF DES	COMMENTS:
33980187	33980179		U0652	
33980188	33980179		U0652	

SAMSUNG  
ELPIDA  
HYNIX

NOTE FOR VSEL...  
0 - 1.8V IO  
1.8V - 3V IO

SYNC MASTER=N/A SYNC DATE=04/18/2011

AP: MAIN

Apple Inc.

DRAWING NUMBER: 051-9374 SIZE: D

REVISION: 13.0.0

BRANCH:

PAGE: 6 OF 102

SHEET: 3 OF 46

NOTICE OF PROPRIETARY PROPERTY:  
THE INFORMATION CONTAINED HEREIN IS THE PROPRIETARY PROPERTY OF APPLE INC. THE POSSESSOR AGREES TO THE FOLLOWING:  
I TO MAINTAIN THIS DOCUMENT IN CONFIDENCE  
II NOT TO REPRODUCE OR COPY IT  
III NOT TO REVEAL OR PUBLISH IT IN WHOLE OR PART  
IV ALL RIGHTS RESERVED



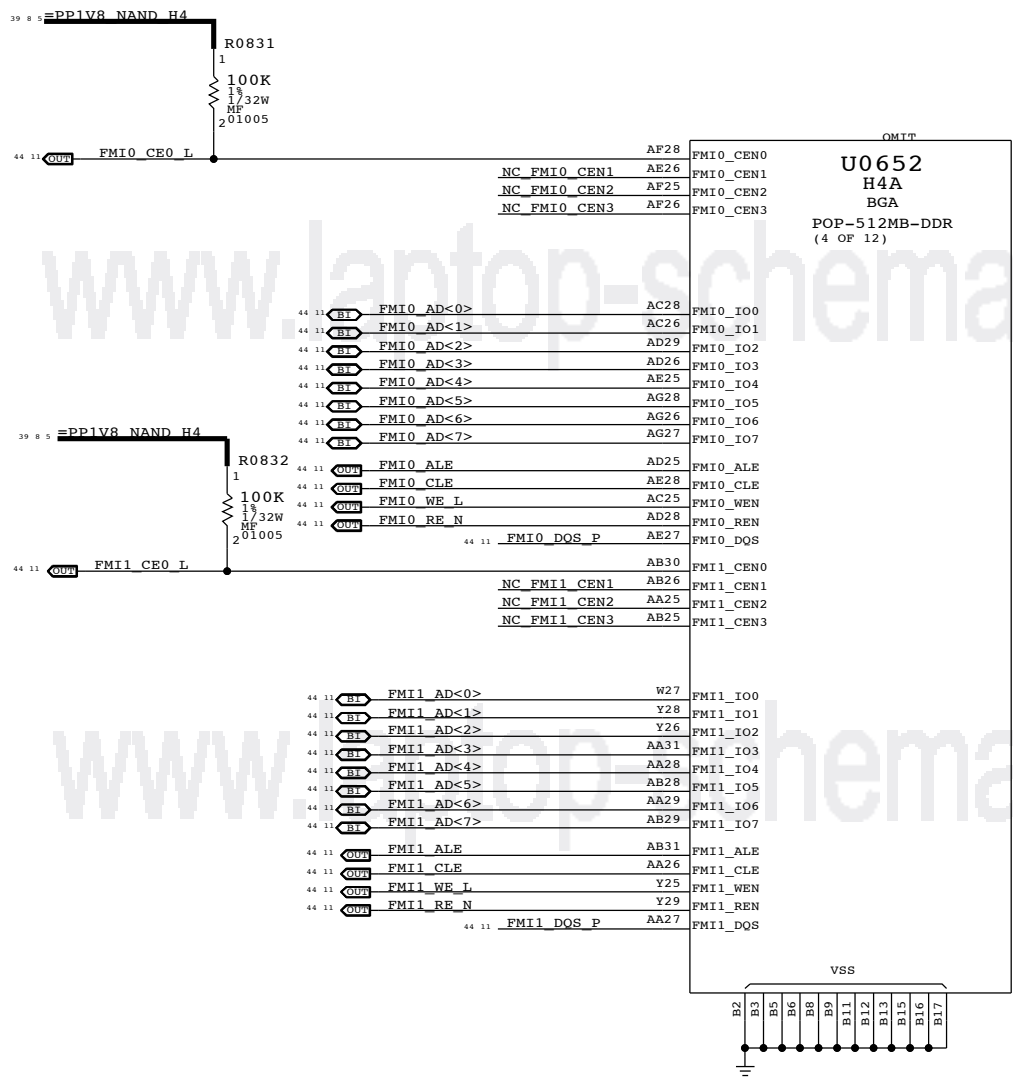

SYNC MASTER=N/A		SYNC DATE=04/18/2011	
AP: FLASH MEMORY INTERFACE			
DRAWING NUMBER		051-9374	SIZE
REVISION		13.0.0	
NOTICE OF PROPRIETARY PROPERTY:		BRANCH	
THE INFORMATION CONTAINED HEREIN IS THE PROPRIETARY PROPERTY OF APPLE INC. THE POSSESSOR AGREES TO THE FOLLOWING:		PAGE	
I TO MAINTAIN THIS DOCUMENT IN CONFIDENCE		8 OF 102	
II NOT TO REPRODUCE OR COPY IT		SHEET	
III NOT TO REVEAL OR PUBLISH IT IN WHOLE OR PART		5 OF 46	
IV ALL RIGHTS RESERVED			



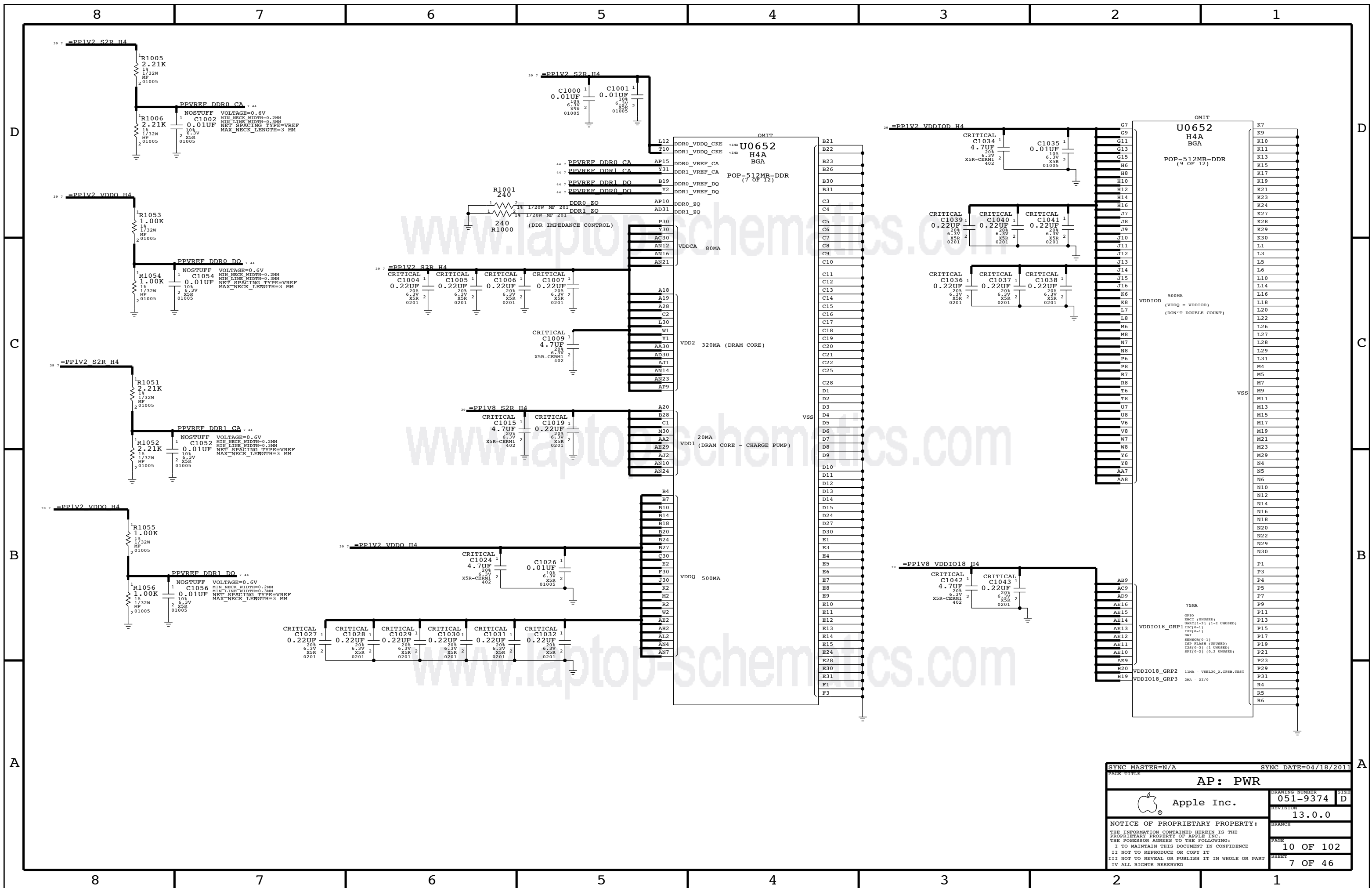

SYNC MASTER=N/A		SYNC DATE=04/18/2011	
PAGE TITLE			
<b>AP: PWR</b>			
	Apple Inc.	DRAWING NUMBER	051-9374
		REVISION	13.0.0
NOTICE OF PROPRIETARY PROPERTY:		BRANCH	
THE INFORMATION CONTAINED HEREIN IS THE PROPRIETARY PROPERTY OF APPLE INC. THE POSSESSOR AGREES TO THE FOLLOWING:		PAGE	10 OF 102
I TO MAINTAIN THIS DOCUMENT IN CONFIDENCE		SHEET	7 OF 46
II NOT TO REPRODUCE OR COPY IT			
III NOT TO REVEAL OR PUBLISH IT IN WHOLE OR PART			
IV ALL RIGHTS RESERVED			

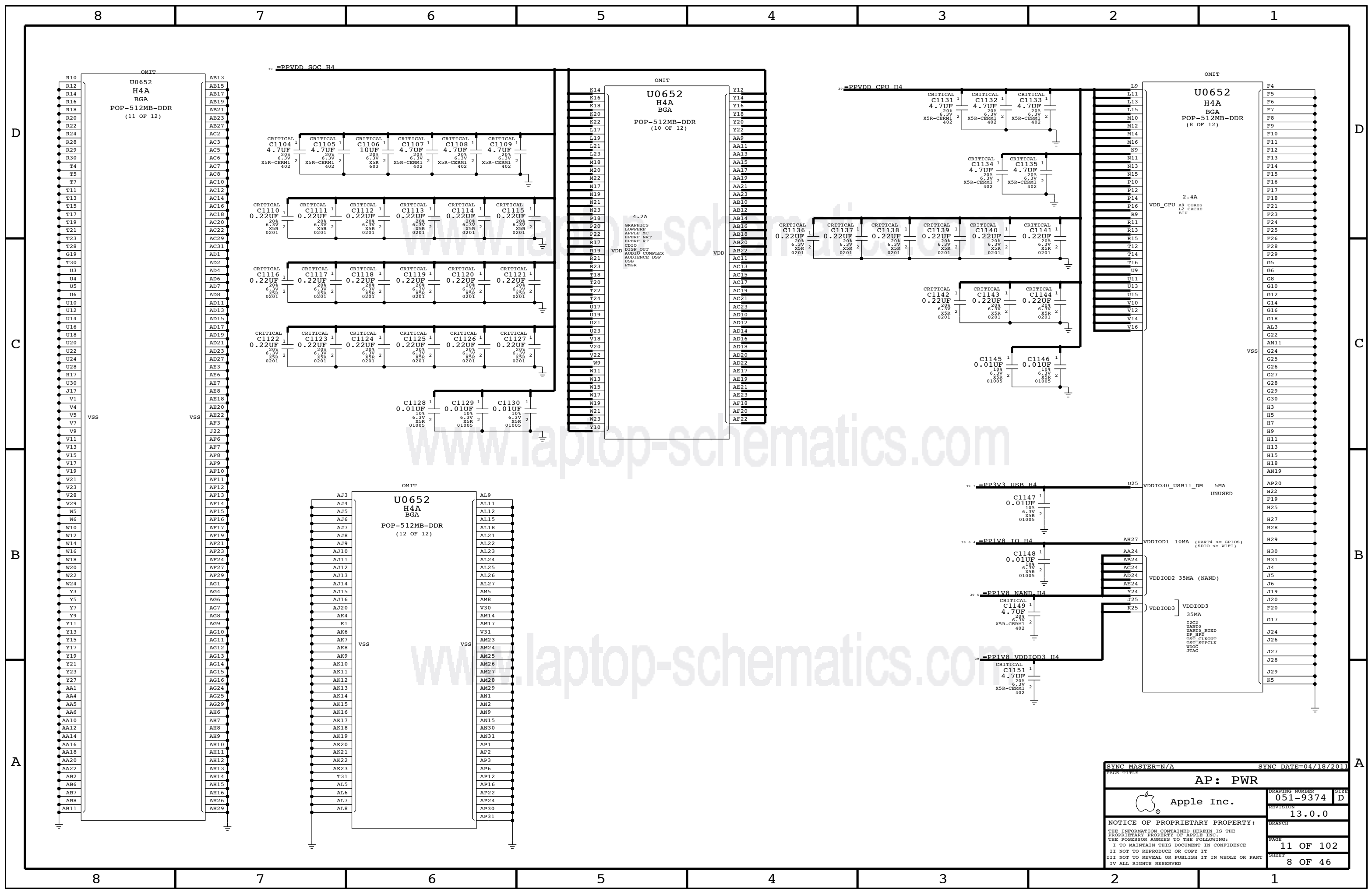

SYNC MASTER=N/A		SYNC DATE=04/18/2011	
PAGE TITLE			
<b>AP: PWR</b>		DRAWING NUMBER	SIZE
Apple Inc.		051-9374	D
NOTICE OF PROPRIETARY PROPERTY: THE INFORMATION CONTAINED HEREIN IS THE PROPRIETARY PROPERTY OF APPLE INC. THE POSSESSOR AGREES TO THE FOLLOWING: I TO MAINTAIN THIS DOCUMENT IN CONFIDENCE II NOT TO REPRODUCE OR COPY IT III NOT TO REVEAL OR PUBLISH IT IN WHOLE OR PART IV ALL RIGHTS RESERVED		REVISION	13.0.0
		PAGE	11 OF 102
		SHEET	8 OF 46

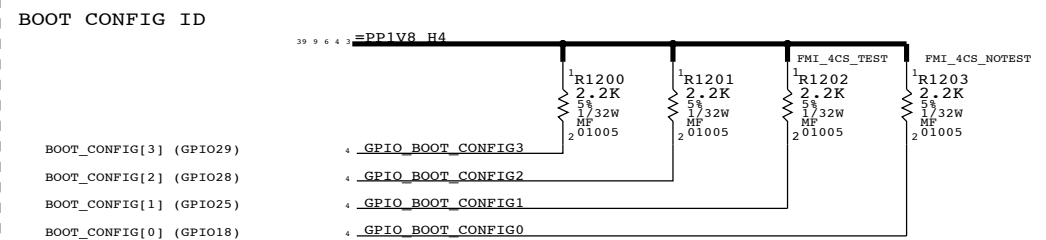

**FOR REFERENCE**

BOOT_CONFIG[3:0]	GPIO
0000	SPI0
0001	SPI3
0010	SPI0 W/TEST
0011	SPI3 W/TEST
0100	FMIO 2CS
0101	FMIO 4CS
0110	FMIO 4CS W/TEST
0111	RESERVED
1000	FMII 2 CS
1001	FMII 4 CS
1010	FMII 4CS W/TEST
1011	RESERVED
1100	FMIO/1 2/2 CS
1101	FMIO/1 4/4 CS
1110	FMIO/1 4/4 CS W/TEST
1111	RESERVED

**S/W READ FLOW**

1. SET GPIO AS INPUT
2. DISABLE PU AND ENABLE PD
3. READ

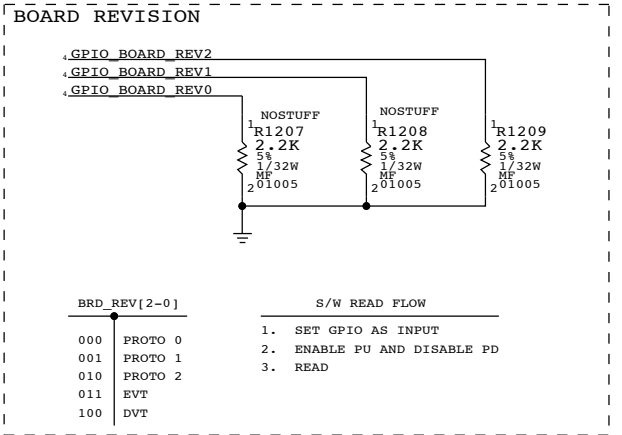
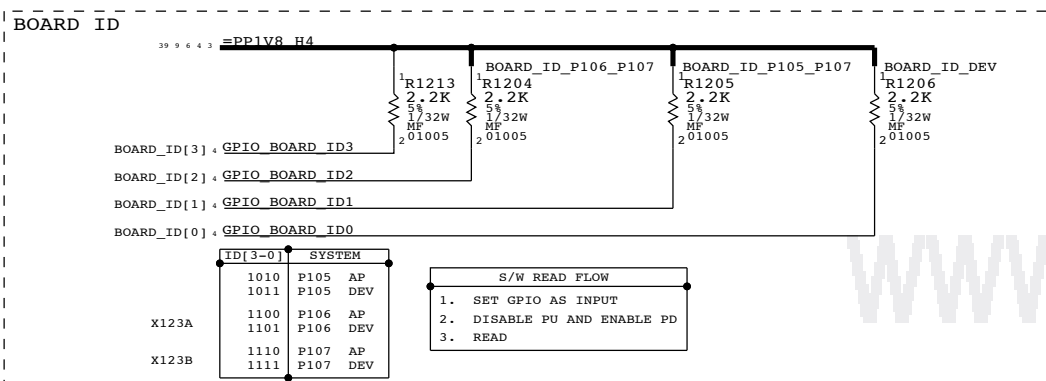
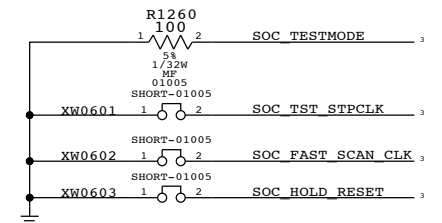
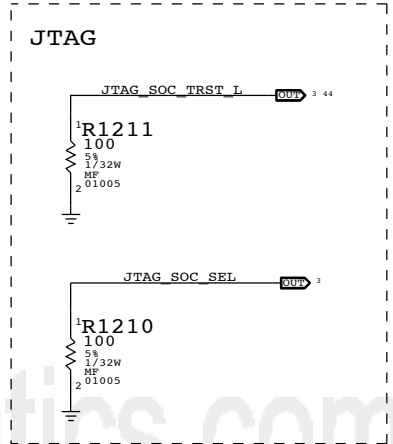
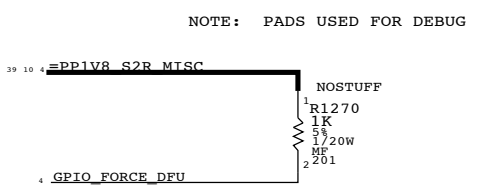

**SINGLE-PIN NETS**

NC_FMIO_DQS_NEG	FMIO_DQS_N
NC_FMIO_RE_POS	FMIO_RE_P
NC_FMII_DQS_NEG	FMII_DQS_N
NC_FMII_RE_POS	FMII_RE_P
NC_PMU_SHDWN	PMU_SHDWN
NC_JTAG_SOC_TDO	JTAG_SOC_TDO
NC_AP_MIPI0C_DPDATA2	NC_MIPI0C_CAM_REAR_DATA_P<2>
NC_AP_MIPI0C_DNDATA2	NC_MIPI0C_CAM_REAR_DATA_N<2>
NC_AP_MIPI0C_DPDATA3	NC_MIPI0C_CAM_REAR_DATA_P<3>
NC_AP_MIPI0C_DNDATA3	NC_MIPI0C_CAM_REAR_DATA_N<3>
NC_AP_MIPI1D_DPCLK	NC_MIPI1D_AP_CLK_P
NC_AP_MIPI1D_DNCLK	NC_MIPI1D_AP_CLK_N
NC_AP_MIPI1D_DPDATA0	NC_MIPI1D_AP_DATA_P<0>
NC_AP_MIPI1D_DNDATA0	NC_MIPI1D_AP_DATA_N<0>
NC_AP_MIPI1D_DPDATA1	NC_MIPI1D_AP_DATA_P<1>
NC_AP_MIPI1D_DNDATA1	NC_MIPI1D_AP_DATA_N<1>
NC_AP_MIPI1C_DPDATA1	NC_MIPI1C_CAM_FRONT_DATA_P<1>
NC_AP_MIPI1C_DNDATA1	NC_MIPI1C_CAM_FRONT_DATA_N<1>
NC_AP_USB11_DPD	NC_USB_FS_D_P
NC_AP_USB11_DND	NC_USB_FS_D_N

SYNC MASTER=N/A SYNC DATE=04/11/2011

**AP: MISC & ALIASES**

Apple Inc.

DRAWING NUMBER: 051-9374 SIZE: D

REVISION: 13.0.0

NOTICE OF PROPRIETARY PROPERTY:

THE INFORMATION CONTAINED HEREIN IS THE PROPRIETARY PROPERTY OF APPLE INC. THE POSSESSOR AGREES TO THE FOLLOWING:

I TO MAINTAIN THIS DOCUMENT IN CONFIDENCE

II NOT TO REPRODUCE OR COPY IT

III NOT TO REVEAL OR PUBLISH IT IN WHOLE OR PART

IV ALL RIGHTS RESERVED

PAGE: 12 OF 102

SHEET: 9 OF 46

PART#	QTY	DESCRIPTION	REFERENCE DESIGNATOR(S)	CRITICAL	BOM OPTION
NXP 34380614	1	IC,ASIC,TRISTAR,CBTL1608,A1,MLCSP36	U1300	CRITICAL	COMMON

PART NUMBER	ALTERNATE FOR PART NUMBER	BOM OPTION	REF DES	COMMENTS
TI 34380620	34380614	COMMON	U1300	IC,ASIC,TRISTAR,CBTL1608,A1,MLCSP36

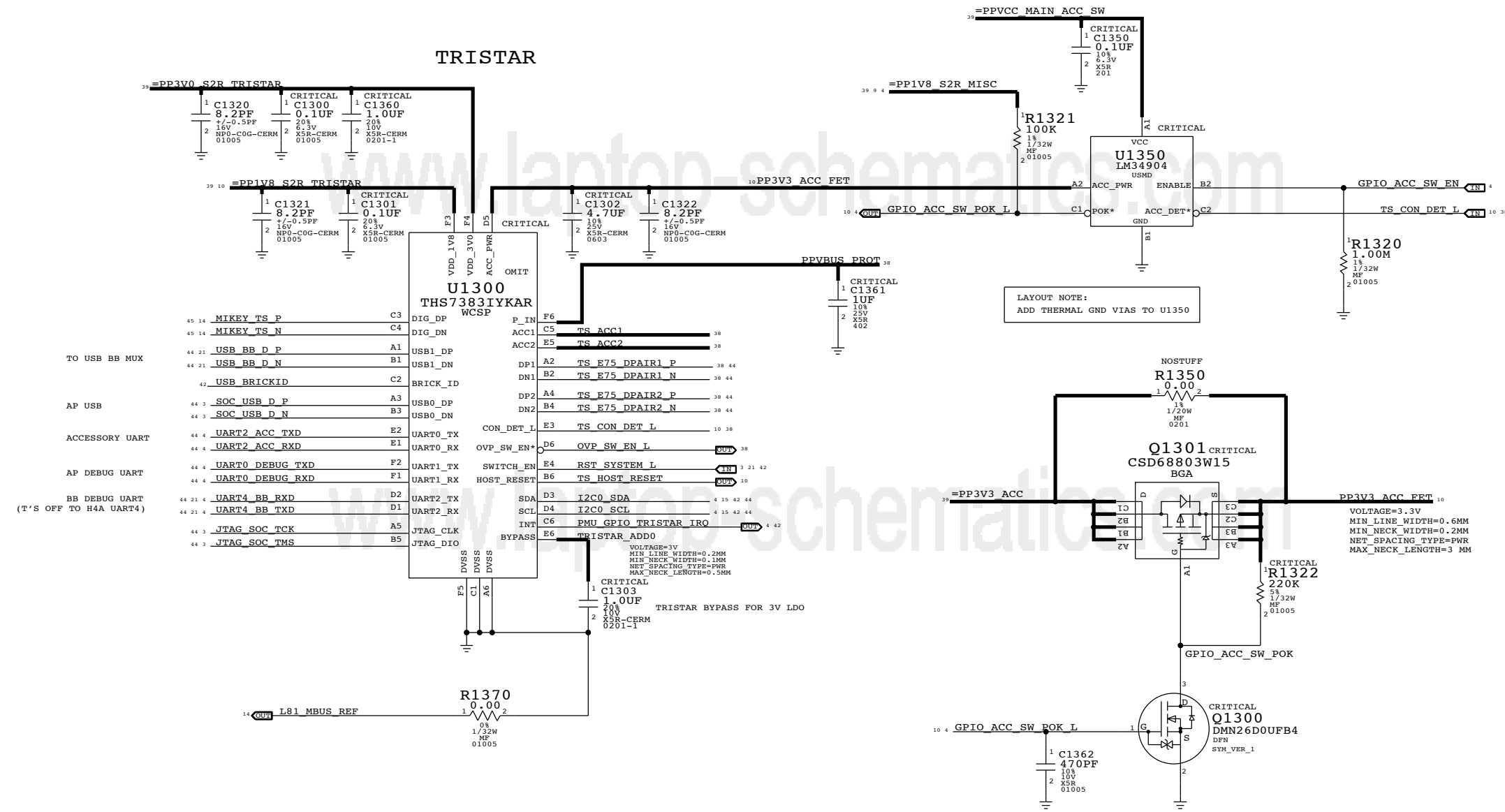

EITHER TRISTAR OR AP CAN RESET PMU

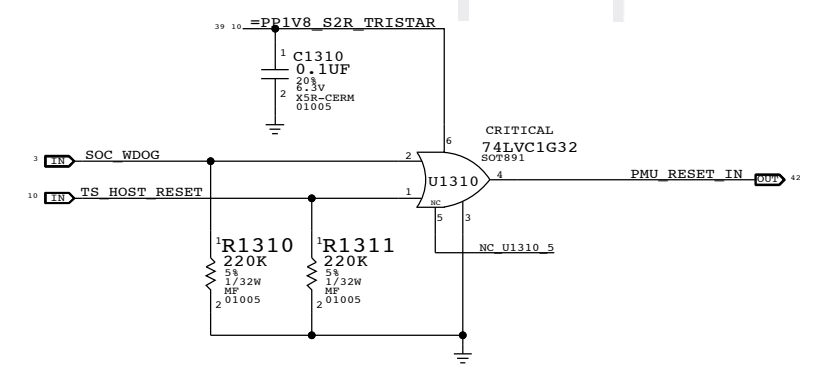

SYNC MASTER=N/A		SYNC DATE=N/A	
<b>E75 SUPPORT</b>			
Apple Inc.		DRAWING NUMBER	SIZE
		051-9374	D
		REVISION	
		13.0.0	
NOTICE OF PROPRIETARY PROPERTY: THE INFORMATION CONTAINED HEREIN IS THE PROPRIETARY PROPERTY OF APPLE INC. THE POSSESSOR AGREES TO THE FOLLOWING: I TO MAINTAIN THIS DOCUMENT IN CONFIDENCE II NOT TO REPRODUCE OR COPY IT III NOT TO REVEAL OR PUBLISH IT IN WHOLE OR PART IV ALL RIGHTS RESERVED		BRANCH	
		PAGE	13 OF 102
		SHEET	10 OF 46

FLASH CONFIGURATIONS

PART NUMBER	ALTERNATE FOR PART NUMBER	BOM OPTION	REF DES	COMMENTS:
335S0889	335S0890	8GB	U1400	HYNIX 20NM PPN1.5 8GB
335S0871	335S0878	16GB	U1400	HYNIX 20NM PPN1.5 16GB
335S0872	335S0879	32GB	U1400	HYNIX 20NM PPN1.5 32GB
335S0873	335S0880	64GB	U1400	HYNIX 20NM PPN1.5 64GB
335S0900	335S0880	16GB	U1400	SANDISK 19NM PPN1.5 16GB
335S0881	335S0880	16GB	U1400	SAMSUNG 21NM PPN1.5 16GB
335S0882	335S0880	32GB	U1400	SAMSUNG 21NM PPN1.5 32GB
335S0883	335S0880	64GB	U1400	SAMSUNG 21NM PPN1.5 64GB

PART#	QTY	DESCRIPTION	REFERENCE DESIGNATOR(S)	BOM OPTION
335S0890	1	TOSHIBA 19NM PPN1.5 8GB	U1400	8GB
335S0878	1	TOSHIBA 19NM PPN1.5 16GB	U1400	16GB
335S0879	1	TOSHIBA 19NM PPN1.5 32GB	U1400	32GB
335S0880	1	TOSHIBA 19NM PPN1.5 64GB	U1400	64GB

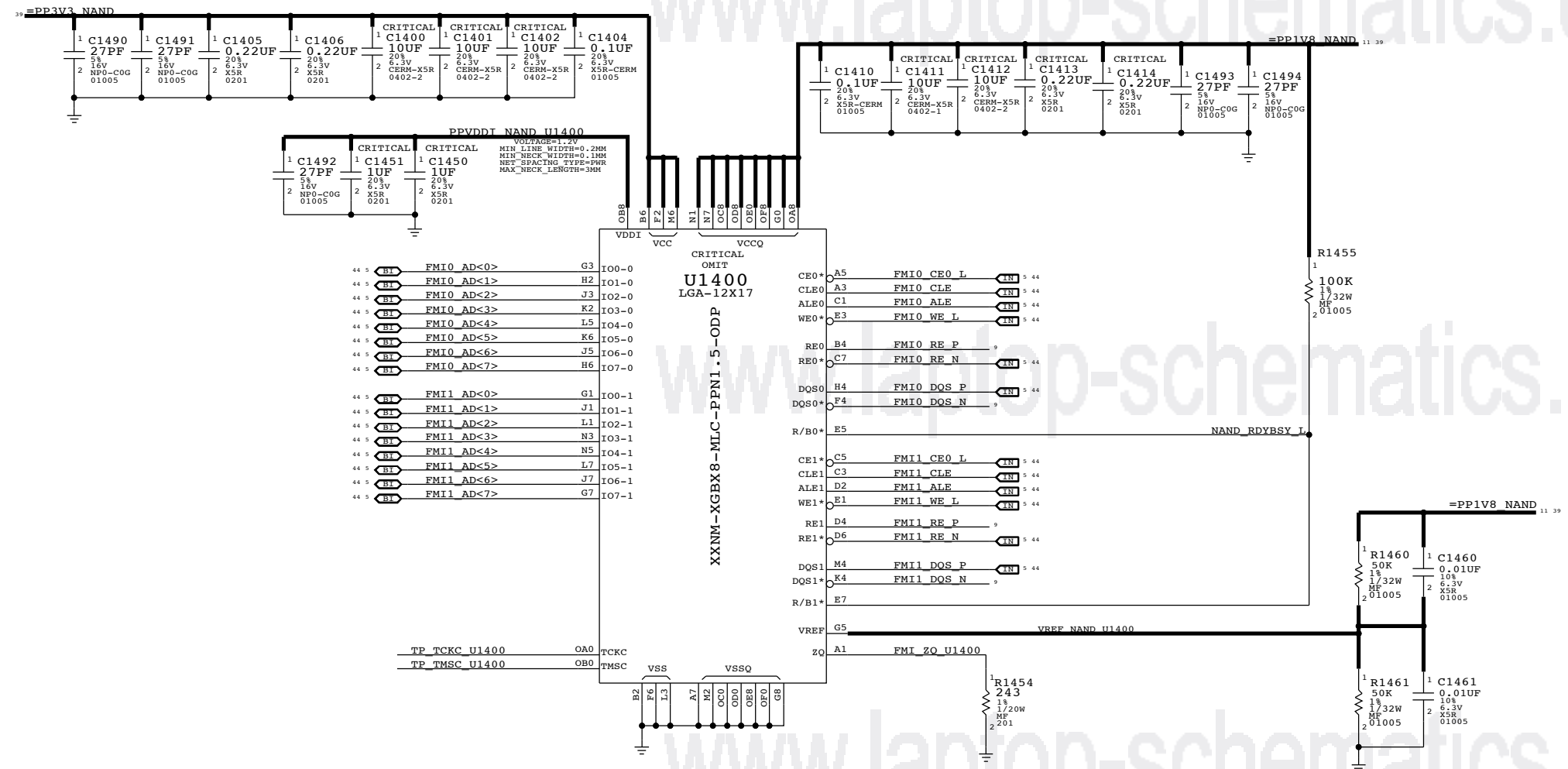

D  
C  
B  
A

D  
C  
B  
A

SYNC MASTER=MLB SYNC DATE=05/04/2012

**NAND STORAGE**

Apple Inc.

DRAWING NUMBER: 051-9374 SIZE: D

REVISION: 13.0.0

NOTICE OF PROPRIETARY PROPERTY: THE INFORMATION CONTAINED HEREIN IS THE PROPRIETARY PROPERTY OF APPLE INC. THE POSSESSOR AGREES TO THE FOLLOWING: I TO MAINTAIN THIS DOCUMENT IN CONFIDENCE II NOT TO REPRODUCE OR COPY IT III NOT TO REVEAL OR PUBLISH IT IN WHOLE OR PART IV ALL RIGHTS RESERVED

PAGE: 14 OF 102 SHEET: 11 OF 46

# TOUCH SUBSYSTEM

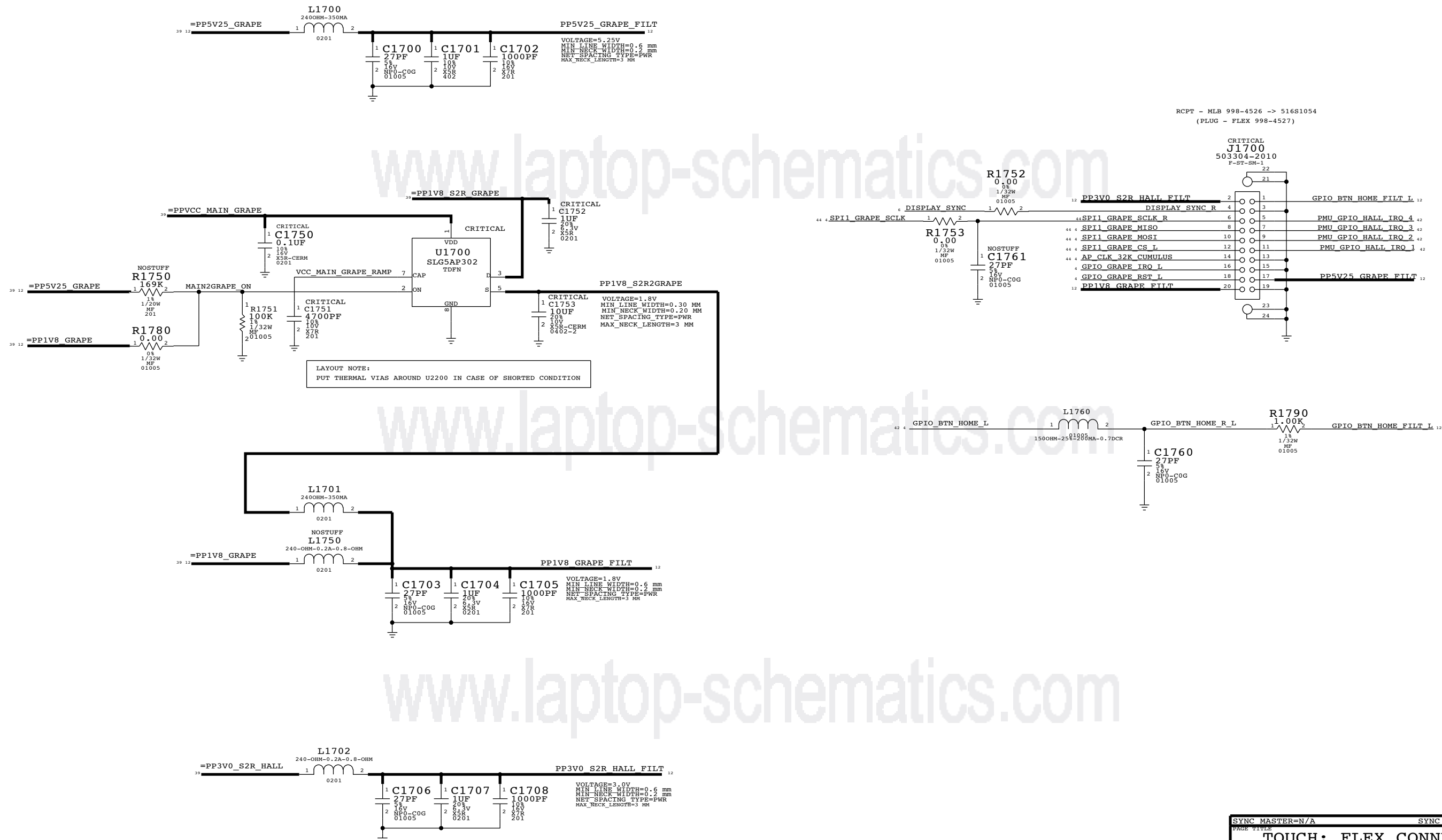

PAGE TITLE		SYNC DATE=06/21/2010	
<b>TOUCH: FLEX CONNECTOR</b>			
Apple Inc.	DRAWING NUMBER	051-9374	SIZE
	REVISION	13.0.0	D
NOTICE OF PROPRIETARY PROPERTY:		BRANCH	
THE INFORMATION CONTAINED HEREIN IS THE PROPRIETARY PROPERTY OF APPLE INC. THE POSSESSOR AGREES TO THE FOLLOWING:		PAGE	
I TO MAINTAIN THIS DOCUMENT IN CONFIDENCE		17 OF 102	
II NOT TO REPRODUCE OR COPY IT		SHEET	
III NOT TO REVEAL OR PUBLISH IT IN WHOLE OR PART		12 OF 46	
IV ALL RIGHTS RESERVED			

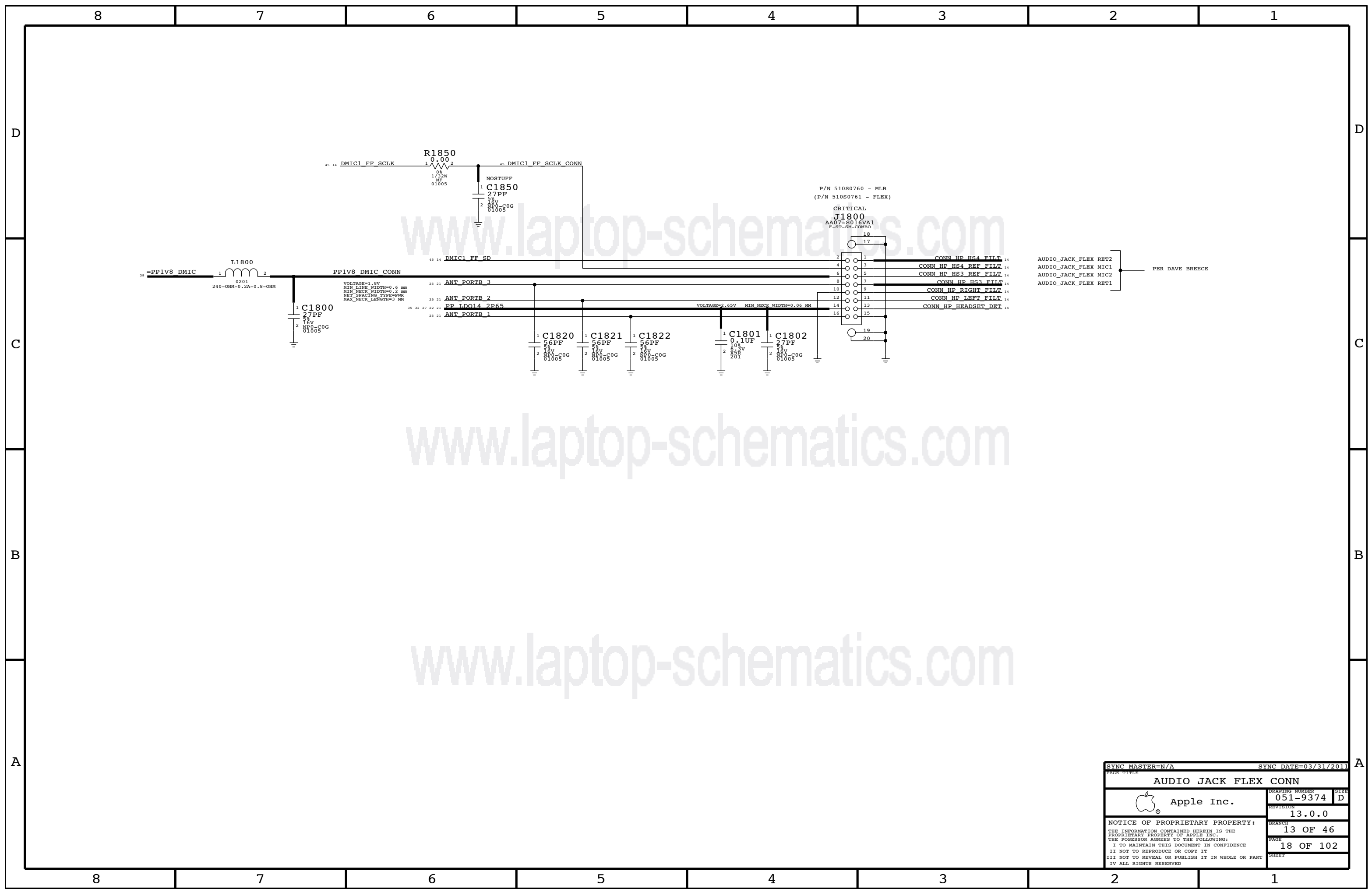

SYNC MASTER=N/A		SYNC DATE=03/31/2011	
<b>AUDIO JACK FLEX CONN</b>			
Apple Inc.		DRAWING NUMBER	051-9374
		REVISION	13.0.0
NOTICE OF PROPRIETARY PROPERTY: THE INFORMATION CONTAINED HEREIN IS THE PROPRIETARY PROPERTY OF APPLE INC. THE POSSESSOR AGREES TO THE FOLLOWING: I TO MAINTAIN THIS DOCUMENT IN CONFIDENCE II NOT TO REPRODUCE OR COPY IT III NOT TO REVEAL OR PUBLISH IT IN WHOLE OR PART IV ALL RIGHTS RESERVED		BRANCH	13 OF 46
		PAGE	18 OF 102
		SHEET	

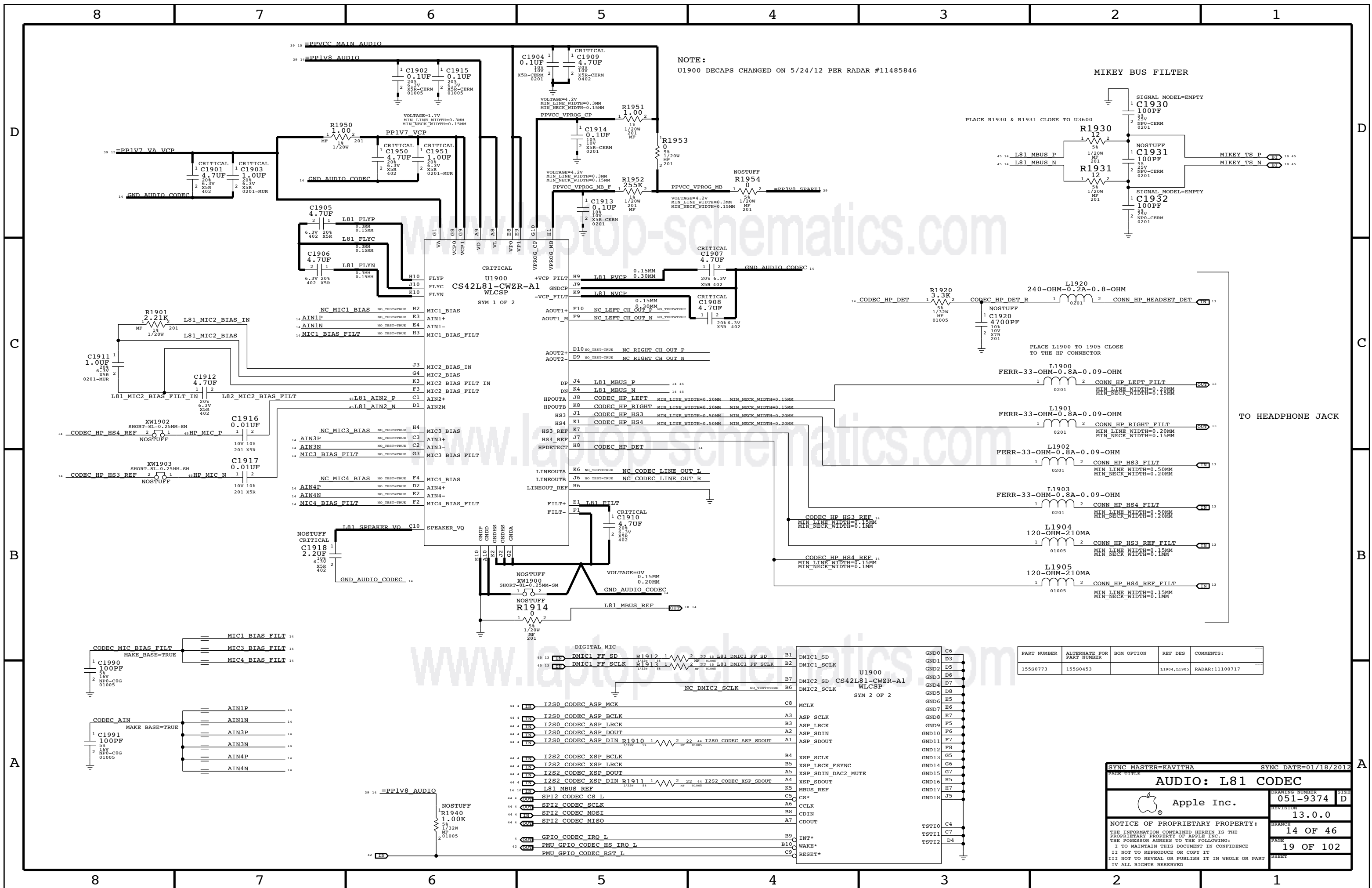

NOTE:  
U1900 DECAPS CHANGED ON 5/24/12 PER RADAR #11485846

MIKEY BUS FILTER

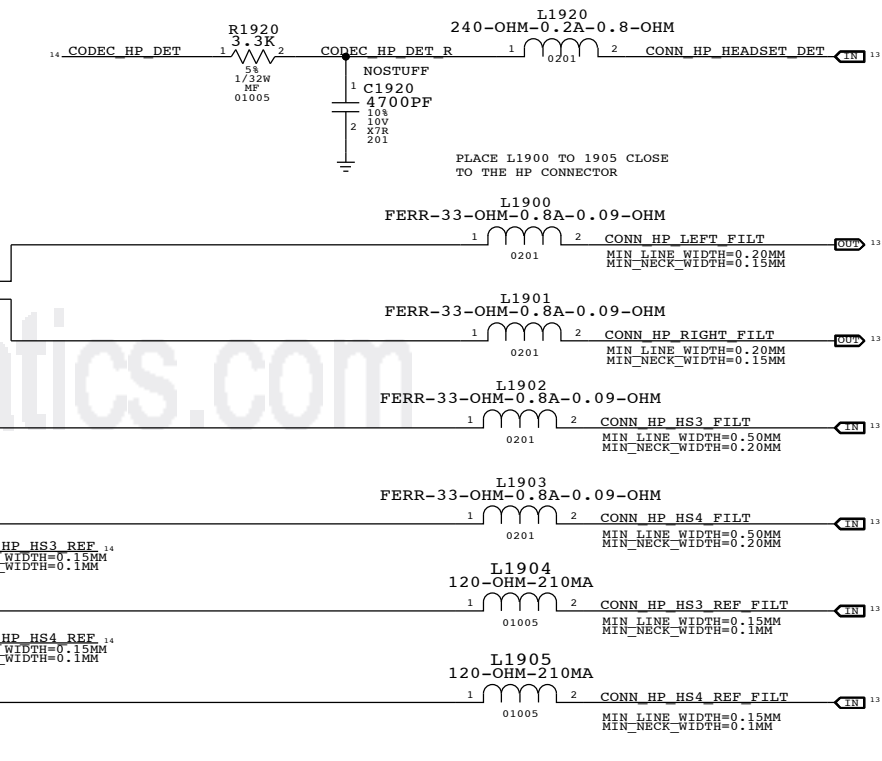
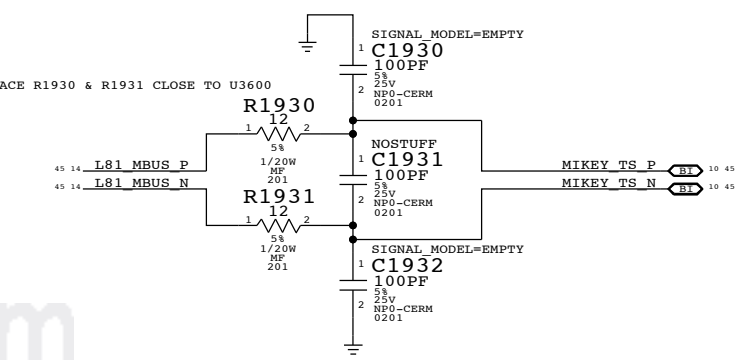

PART NUMBER	ALTERNATE FOR PART NUMBER	BOM OPTION	REF DES	COMMENTS:
15580773	15580453		L1904, L1905	RADAR:11100717

U1900	CS42L81-CWZR-A1	WLCSP	SYM 1 OF 2
B1	DMIC1_SD		
B2	DMIC1_SCLK		
B6	DMIC2_SCLK		
C8	MCLK		
A3	ASP_SCLK		
B3	ASP_LRCK		
A2	ASP_SDIN		
A1	ASP_SDOUT		
B4	XSP_SCLK		
B5	XSP_LRCK_FSYNC		
A5	XSP_SDIN_DAC2_MUTE		
A4	XSP_SDOUT		
K5	MBUS_REF		
C5	CS*		
A6	CCLK		
B8	CDIN		
A7	CDOUT		
B9	INT*		
B10	WAKE*		
C9	RESET*		

SYNC MASTER=KAVITHA SYNC DATE=01/18/2012

**AUDIO: L81 CODEC**

Apple Inc.

DRAWING NUMBER: 051-9374 SIZE: D

REVISION: 13.0.0

BRANCH: 14 OF 46

PAGE: 19 OF 102

NOTICE OF PROPRIETARY PROPERTY:  
THE INFORMATION CONTAINED HEREIN IS THE PROPRIETARY PROPERTY OF APPLE INC. THE POSSESSOR AGREES TO THE FOLLOWING:  
I TO MAINTAIN THIS DOCUMENT IN CONFIDENCE  
II NOT TO REPRODUCE OR COPY IT  
III NOT TO REVEAL OR PUBLISH IT IN WHOLE OR PART  
IV ALL RIGHTS RESERVED

# RIGHT SPEAKER AMP

I2C ADDRESS: 100001X

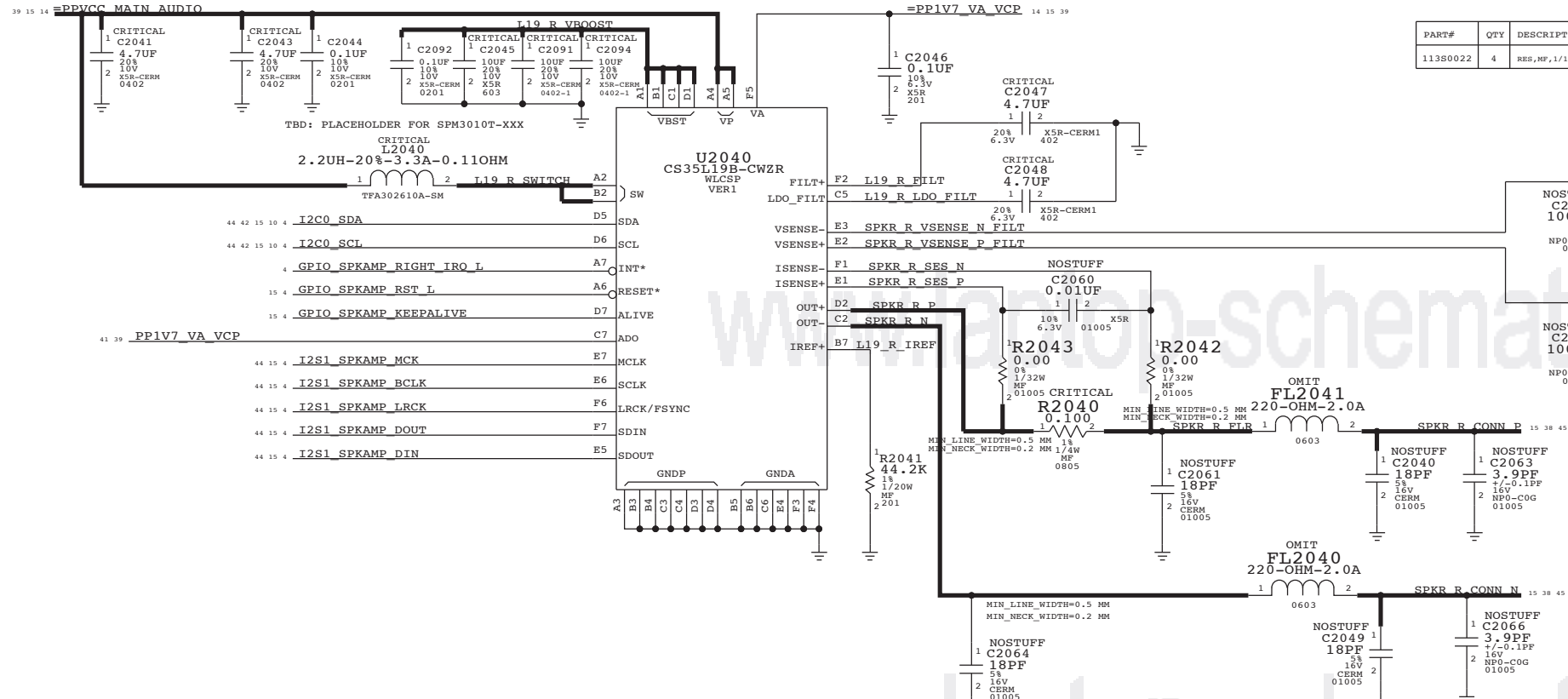

PART#	QTY	DESCRIPTION	REFERENCE DESIGNATOR(S)	CRITICAL	BOM OPTION
113S0022	4	RES,MP,1/10W,0 OHM,5%,0603,SMD,LF	FL2040,FL2041,FL2050,FL2051		

# SPEAKER CONNECTOR

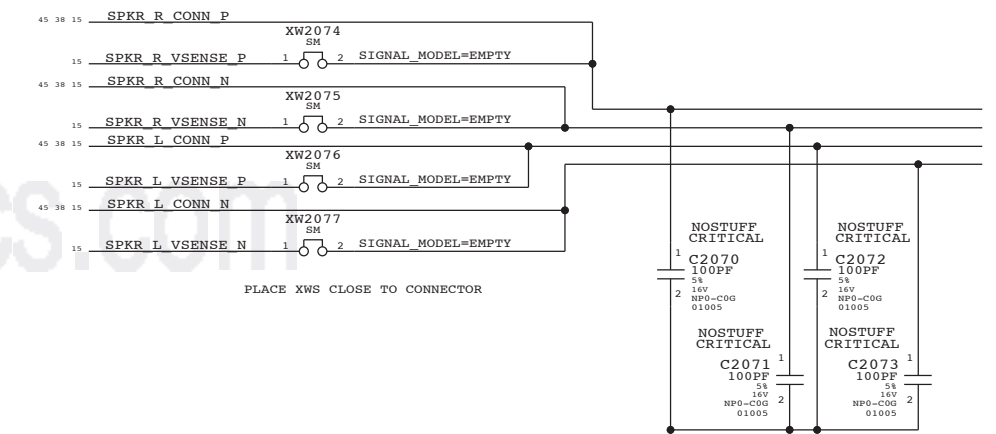

# LEFT SPEAKER AMP

I2C ADDRESS: 1000000X

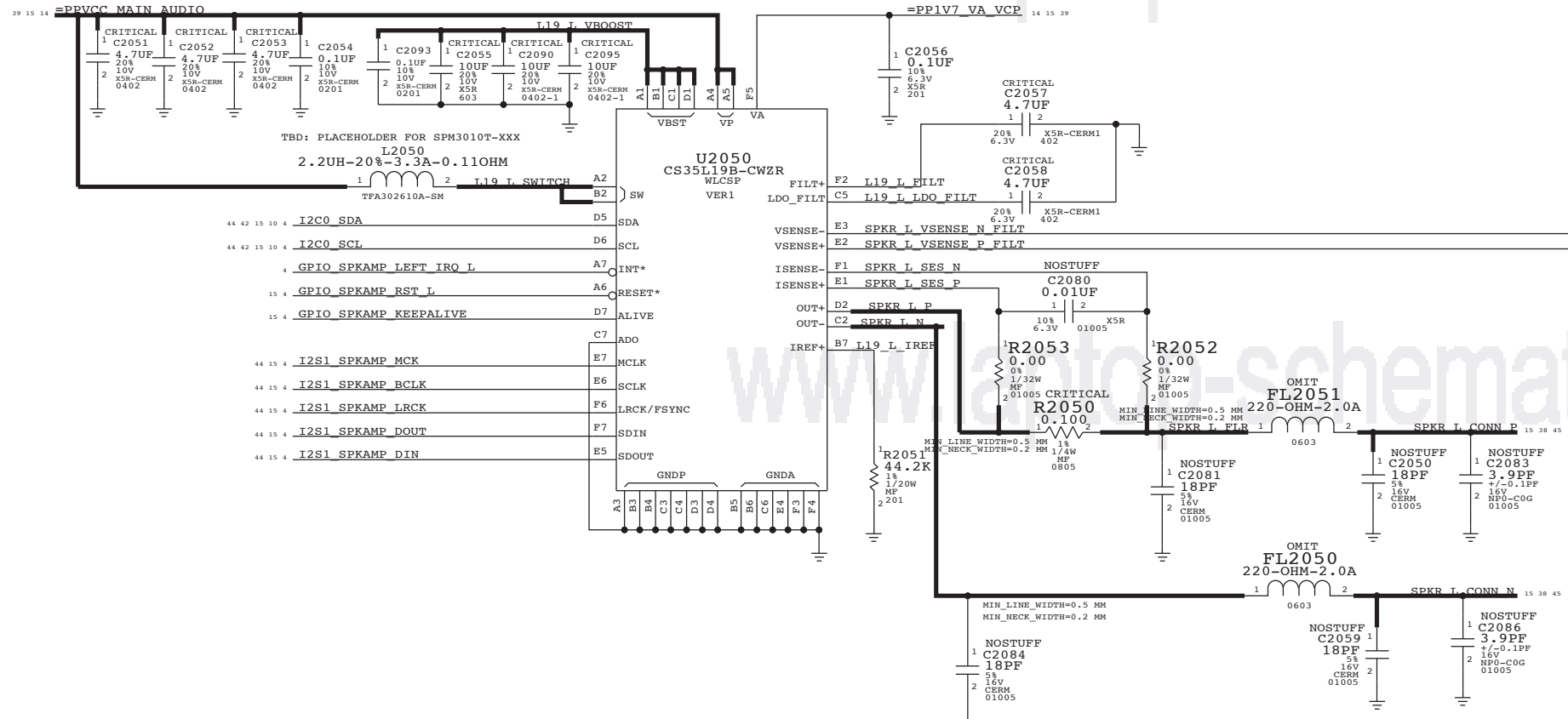

SYNC MASTER=KAVITHA		SYNC DATE=01/18/2012	
PAGE TITLE			
AUDIO: CS35L19A AMPS			
Apple Inc.		DRAWING NUMBER	051-9374
		REVISION	13.0.0
NOTICE OF PROPRIETARY PROPERTY:		BRANCH	4 OF 4
THE INFORMATION CONTAINED HEREIN IS THE PROPRIETARY PROPERTY OF APPLE INC. THE POSSESSOR AGREES TO THE FOLLOWING:		PAGE	20 OF 102
I TO MAINTAIN THIS DOCUMENT IN CONFIDENCE		SHEET	15 OF 46
II NOT TO REPRODUCE OR COPY IT			
III NOT TO REVEAL OR PUBLISH IT IN WHOLE OR PART			
IV ALL RIGHTS RESERVED			

# MIPI CONNECTOR

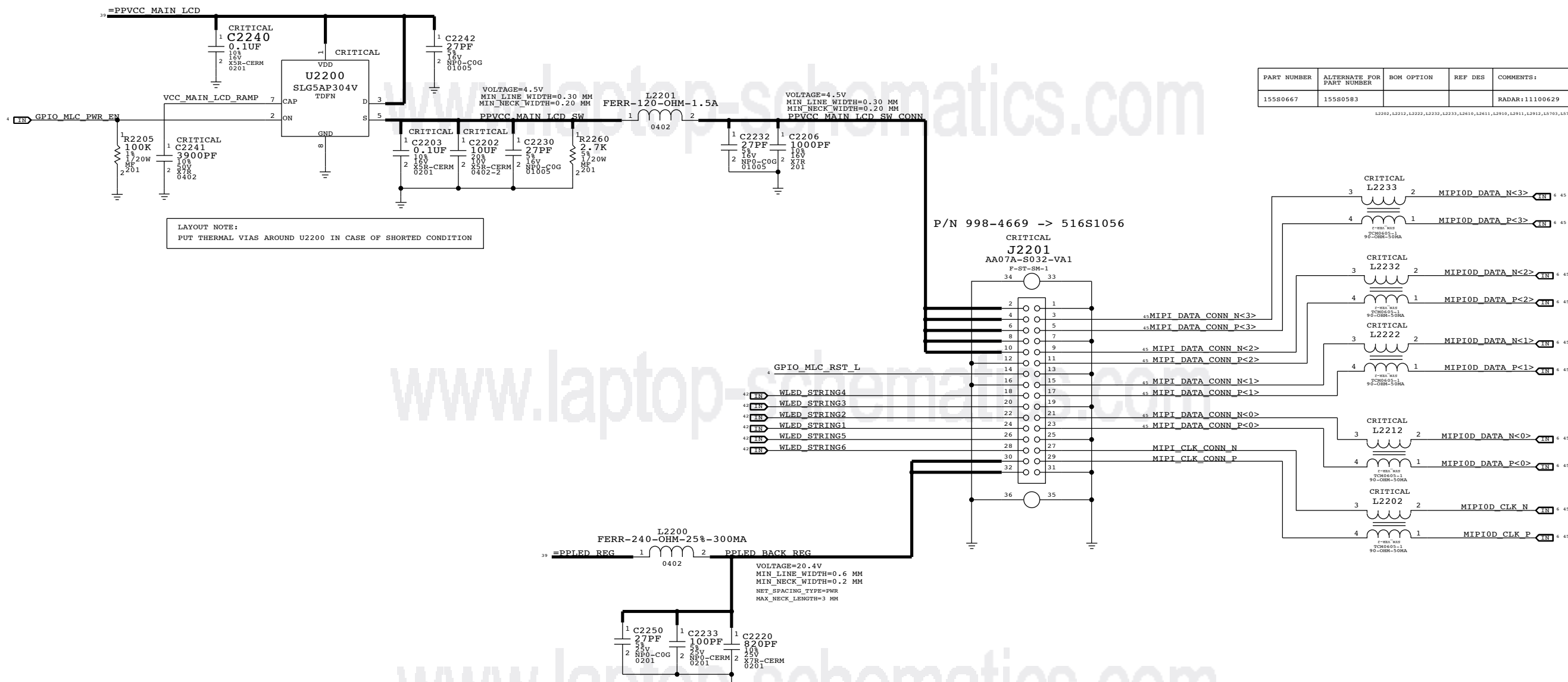

SYNC MASTER=N/A		SYNC DATE=N/A	
VIDEO: MIPI CONNECTOR			
DRAWING NUMBER		SIZE	
051-9374		D	
REVISION		BRANCH	
13.0.0			
NOTICE OF PROPRIETARY PROPERTY:			
THE INFORMATION CONTAINED HEREIN IS THE PROPRIETARY PROPERTY OF APPLE INC. THE POSSESSOR AGREES TO THE FOLLOWING:			
I TO MAINTAIN THIS DOCUMENT IN CONFIDENCE			
II NOT TO REPRODUCE OR COPY IT			
III NOT TO REVEAL OR PUBLISH IT IN WHOLE OR PART			
IV ALL RIGHTS RESERVED			
PAGE		SHEET	
22 OF 102		16 OF 46	

# VGA FRONT CAMERA CONNECTOR

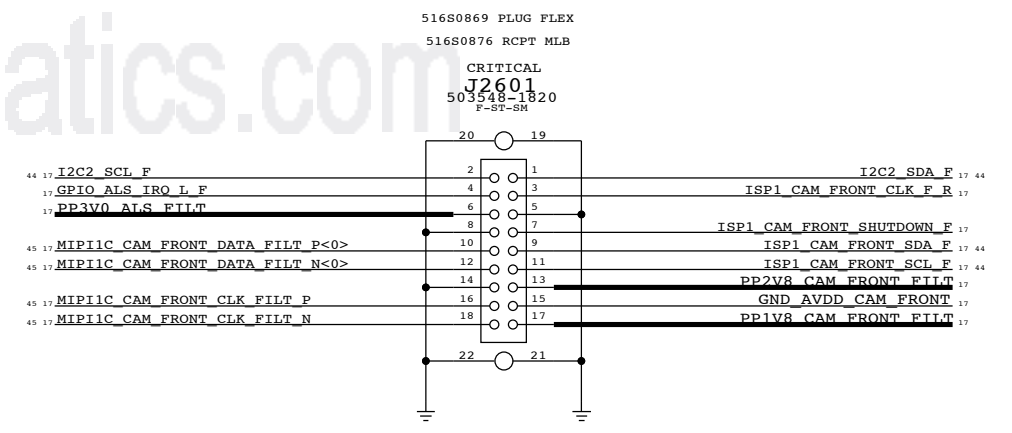
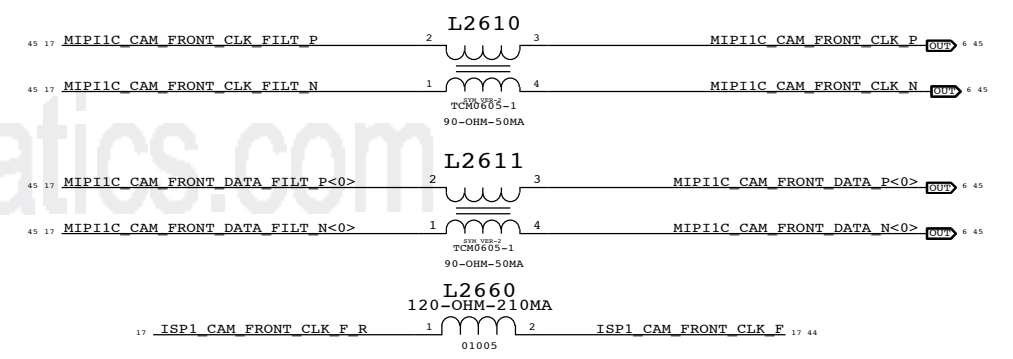
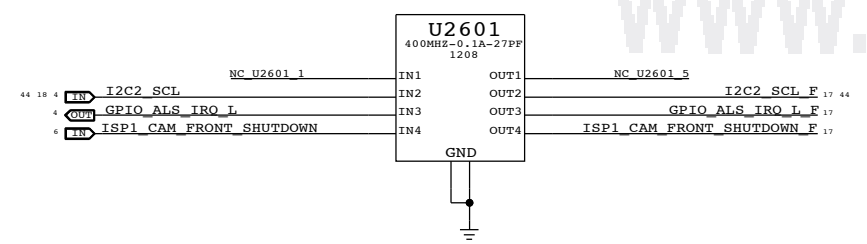
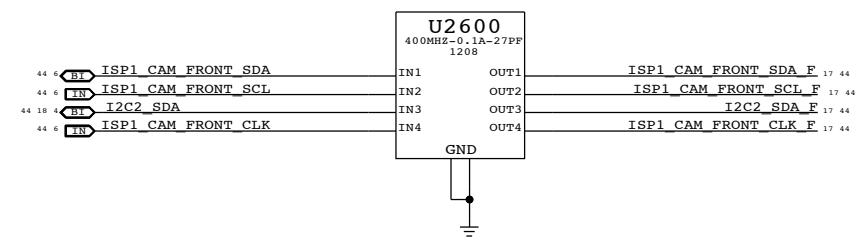
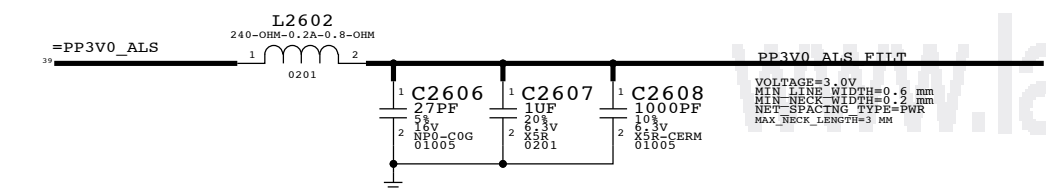
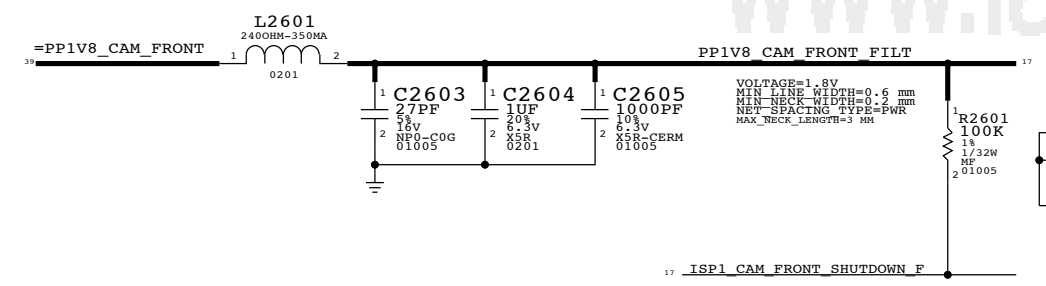
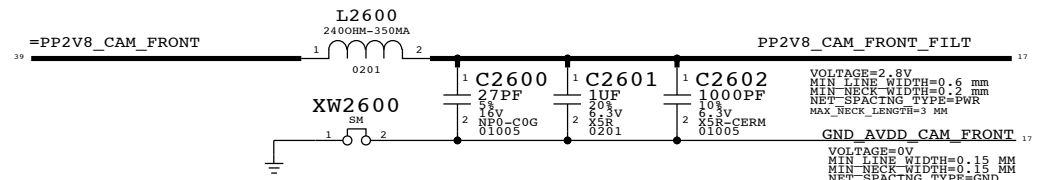

PAGE TITLE		SYNC MASTER=N/A		SYNC DATE=N/A	
<b>FF CAM &amp; MIC CONNECTORS</b>					
		DRAWING NUMBER	051-9374	SIZE	D
		REVISION	13.0.0	BRANCH	
NOTICE OF PROPRIETARY PROPERTY:					
THE INFORMATION CONTAINED HEREIN IS THE PROPRIETARY PROPERTY OF APPLE INC. THE POSSESSOR AGREES TO THE FOLLOWING:					
I TO MAINTAIN THIS DOCUMENT IN CONFIDENCE					
II NOT TO REPRODUCE OR COPY IT					
III NOT TO REVEAL OR PUBLISH IT IN WHOLE OR PART					
IV ALL RIGHTS RESERVED					
		PAGE	26 OF 102		
		SHEET	17 OF 46		

# ACCELEROMETER

(WRITE: 0X3A READ: 0X3B)

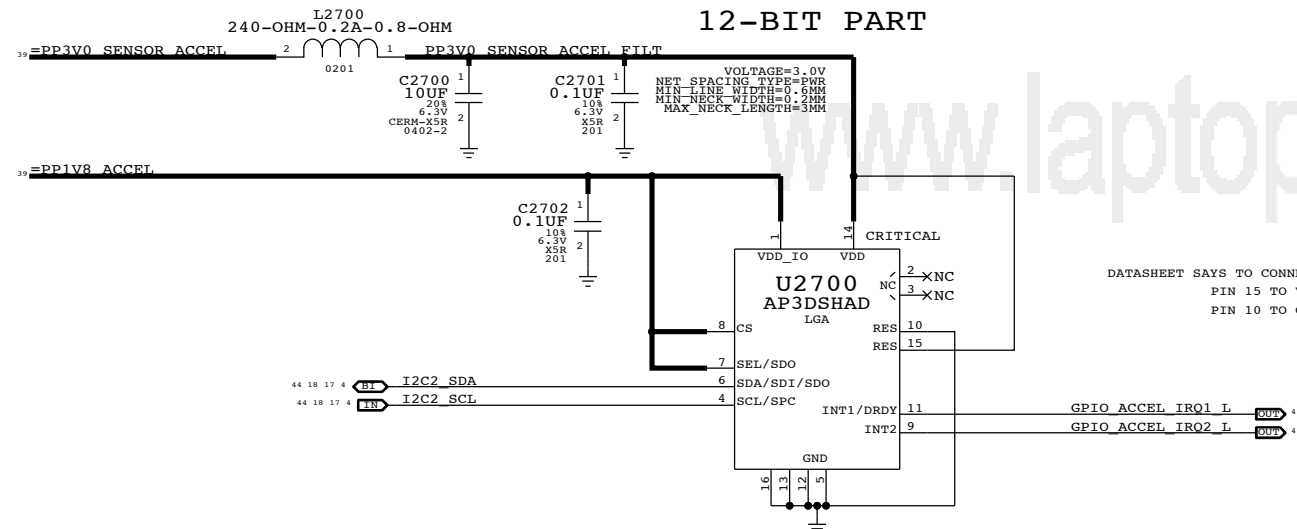

# GYRO

(WRITE: 0XD4 READ: 0XD5)

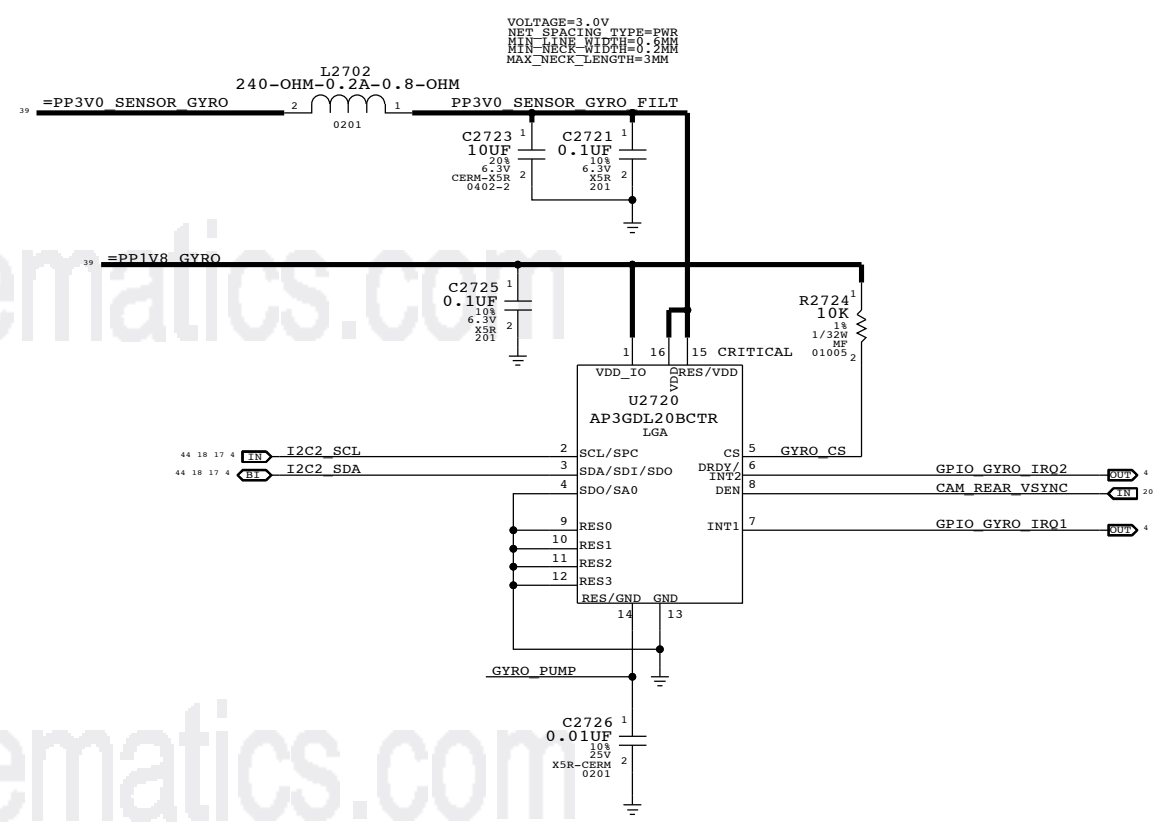

# COMPASS

WRITE: 0X18 READ: 0X19

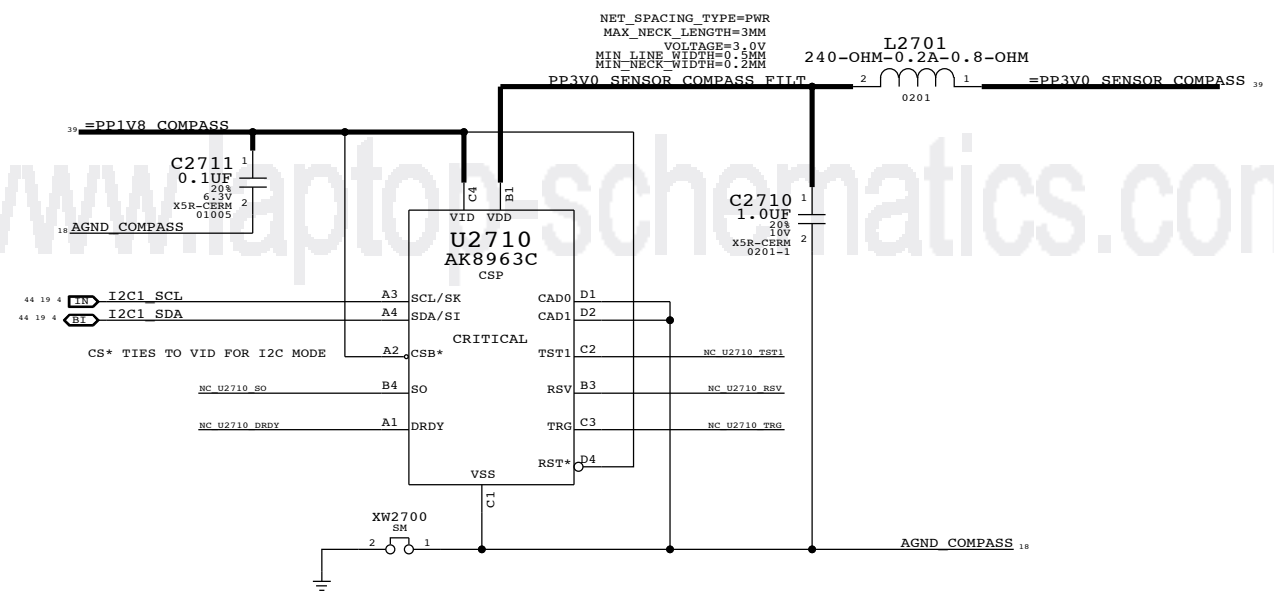

SYNC MASTER=N/A		SYNC DATE=N/A	
<b>INERTIAL SENSORS</b>			
Apple Inc.		DRAWING NUMBER	051-9374
		REVISION	13.0.0
NOTICE OF PROPRIETARY PROPERTY: THE INFORMATION CONTAINED HEREIN IS THE PROPRIETARY PROPERTY OF APPLE INC. THE POSSESSOR AGREES TO THE FOLLOWING: I TO MAINTAIN THIS DOCUMENT IN CONFIDENCE II NOT TO REPRODUCE OR COPY IT III NOT TO REVEAL OR PUBLISH IT IN WHOLE OR PART IV ALL RIGHTS RESERVED		BRANCH	
		PAGE	27 OF 102
		SHEET	18 OF 46



# REAR CAMERA CONNECTOR

APN: 516S0973  
PLUG: 516S0974

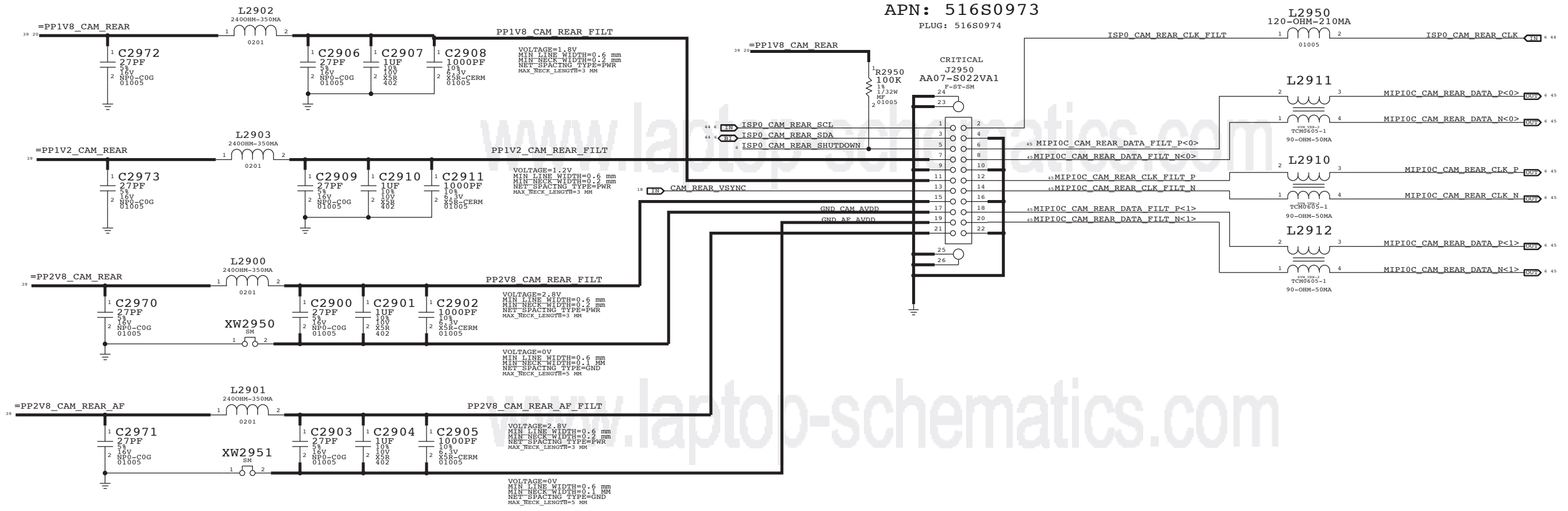

# BUTTON CONNECTOR

CRITICAL  
J2960  
FF18-6A-R11AD-B-3H  
F-RT-SM

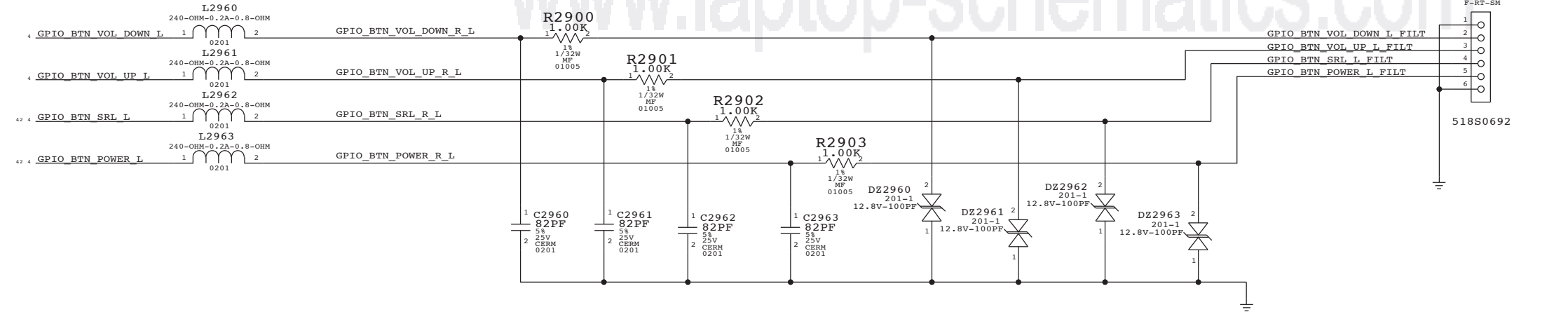

PAGE TITLE		SYNC DATE=N/A	
<b>BUTTON &amp; REAR CAMERA CONN</b>			
	DRAWING NUMBER	051-9374	SIZE
	REVISION	13.0.0	D
NOTICE OF PROPRIETARY PROPERTY: THE INFORMATION CONTAINED HEREIN IS THE PROPRIETARY PROPERTY OF APPLE INC. THE POSSESSOR AGREES TO THE FOLLOWING: I TO MAINTAIN THIS DOCUMENT IN CONFIDENCE II NOT TO REPRODUCE OR COPY IT III NOT TO REVEAL OR PUBLISH IT IN WHOLE OR PART IV ALL RIGHTS RESERVED		BRANCH	
		PAGE	29 OF 102
		SHEET	20 OF 46

# AP INTERFACE & DEBUG CONNECTOR

CONFIDENTIAL AND PROPRIETARY APPLE SYSTEM DESIGN. FOR REFERENCE PURPOSES ONLY - NOT A CHANGE REQUEST.

## AP CONNECTIONS

34 33 31 30 29 23 22 21	PP_BATT_VCC_CONN	=	PPBATT_VCC_RF	39
25	TX_GTR_THRESH	=	GPIO_BB_GSM_TXBURST	4
24 23 21	BB_RST_L	=	GPIO_BB_RST_L	4
24 23 21	RESET_DET_L	=	GPIO_BB_RST_DET_L	4
23 21	RADIO_ON_L	=	GPIO_BB_RADIO_ON_L	4
23 21	RESET_PMU_L	=	PMU_GPIO_BB_RST_L	42
25 21	BB_WAKE_HOST	=	PMU_GPIO_BB_WAKE	42
21	RF_RESET_L	=	RST_SYSTEM_L	3 10 42
25 21	PBL_RUN_BB_HSI1_RDY	=	GPIO_BB_HSI1_DEV_RDY	4
25	AP_WAKE_MODEM	=	GPIO_BB_IPC_GPIO	4
25 21	AP_HSI1_RDY	=	GPIO_BB_HSI1_HOST_RDY	4
24 21	50_HSI1_BB_DATA	=	HSI1_BB_DATA	3 44
24 21	50_HSI1_BB_STROBE	=	HSI1_BB_STB	3 44

25	BB_HSI1_REMOTE_WAKE	=	GPIO_BB_DIAGS_RDY	4
25 21	BB_UART_TXD	=	UART4_BB_RXD	4 10 44
25 21	BB_UART_RXD	=	UART4_BB_TXD	4 10 44
25 21	BB_UART_RTS_L	=	UART4_BB_CTS_L	4 44
25 21	BB_UART_CTS_L	=	UART4_BB_RTS_L	4 44
24 21	BB_USB_VBUS	=	BB_VBUS_DET	42
24 21	90_BB_USB_D_P	=	USB_BB_D_P	10 44
24 21	90_BB_USB_D_N	=	USB_BB_D_N	10 44

37	PP_WLAN_MAIN_VCC	=	PPBATT_VCC_WL	39
25	PP_SYNC	=	GPIO_BB_GPS_SYNC	4
37	PP_WL_BT_VDDIO_AP	=	PP1V8_S2R_WL	39
37	CLK32K_AP	=	PMU_CLK_32K_WLAN	42 44

37	WLAN_REG_ON	=	PMU_GPIO_WLAN_REG_ON	42
37	WLAN_UART_TXD	=	UART3_WLAN_RXD	4 44
37	WLAN_UART_RXD	=	UART3_WLAN_TXD	4 44
37	WLAN_HOST_WAKE	=	PMU_GPIO_WLAN_HOST_WAKE	42

37	WLAN_HSI3_RESUME	=	GPIO_WLAN_HSI3_RESUME	4
37	DEV_HSI3_RDY	=	GPIO_WLAN_HSI3_DEV_RDY	4
37	AP_HSI3_RDY	=	GPIO_WLAN_HSI3_HOST_RDY	4 44
37	50_HSI1_WLAN_DATA	=	HSI1_WLAN_DATA	3 44
37	50_HSI1_WLAN_STROBE	=	HSI1_WLAN_STB	3 44

37	BT_HOST_WAKE	=	PMU_GPIO_BT_HOST_WAKE	42
37 21	BT_WAKE	=	GPIO_BT_WAKE	4
37 21	BT_UART_TXD	=	UART1_BT_RXD	4 44
37 21	BT_UART_RXD	=	UART1_BT_TXD	4 44
37 21	BT_UART_RTS_L	=	UART1_BT_CTS_L	4 44
37 21	BT_UART_CTS_L	=	UART1_BT_RTS_L	4 44
37 21	BT_REG_ON	=	PMU_GPIO_BT_REG_ON	42
37 21	BT_PCM_CLK	=	I2S3_BT_BCLK	4 44
37 21	BT_PCM_SYNC	=	I2S3_BT_LRCK	4 44
37 21	BT_PCM_OUT	=	I2S3_BT_DIN	4 44
37 21	BT_PCM_IN	=	I2S3_BT_DOUT	4 44

25 21 13	ANT_PORTB_1	=	ANT_PORTB_1	13 21 25
25 21 13	ANT_PORTB_2	=	ANT_PORTB_2	13 21 25
25 21 13	ANT_PORTB_3	=	ANT_PORTB_3	13 21 25
25 21	LAT_SW1_CTL	=	ANT_PORTA_1	13 21 25
35 32 27 22 13	PP_LDO14_2P65	=	PP_LDO14_2P65	13 21 27 32 35

PARTS TABLE FOR P105 SIM CARD, WHILE PINOUT IS BEING FIXED

PART#	QTY	DESCRIPTION	REFERENCE DESIGNATOR(S)	BOM OPTION
512S0088	1	P105 SIM TRAY	J31001_RF	CELL

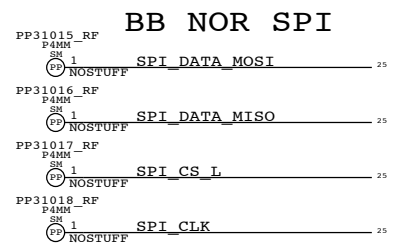
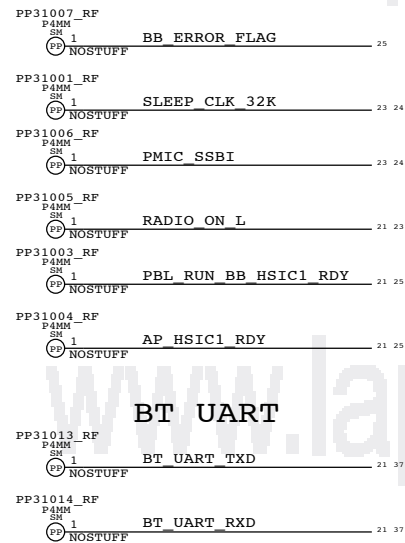

## SIM CARD CONNECTOR

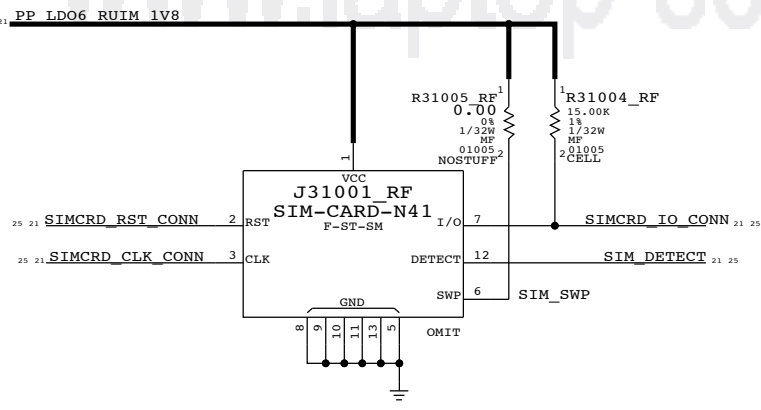

## DEBUG CONNECTOR

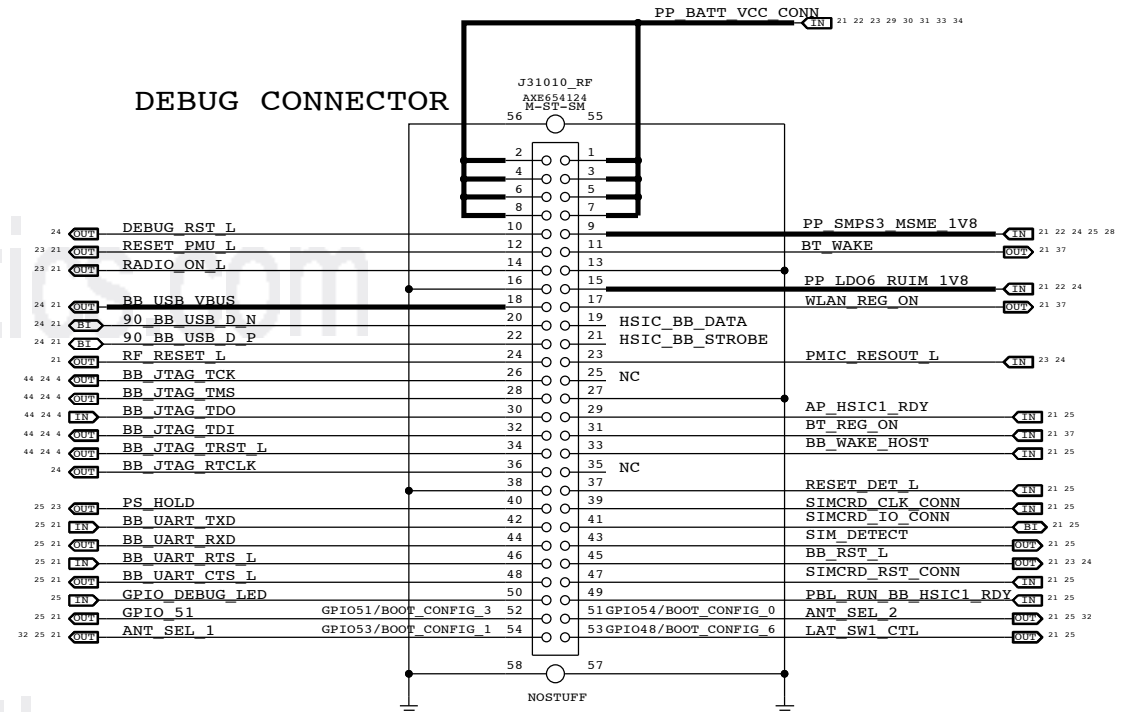

BOOT OPTIONS	BOOT_CONFIG SW REGISTER VALUE	GPIO/BOOT_CONFIG CONFIGURATION								
		6	5	4	3	2	1	0		
BOOT_DEFAULT_OPTION	0X00	X	0	0	0	0	0	0	0	X
BOOT_NAND_OPTION	0X01	X	1	0	0	0	0	0	1	X
BOOT_HSI3_OPTION	0X02	X	1	0	0	0	0	1	0	X
BOOT_USB_OPTION	0X03	X	1	0	0	0	0	1	1	X
ENABLE_SAHARA_PROTOCOL	0X08	X	1	0	0	1	0	X	X	X

R R104  
C CXXX  
XWXW206  
DZDZ101  
U U101

SYSTEM & DEBUG CONNECTORS		PAGE TITLE
Apple Inc.		DRAWING NUMBER 051-9374
NOTICE OF PROPRIETARY PROPERTY:		REVISION 13.0.0
THE INFORMATION CONTAINED HEREIN IS THE PROPRIETARY PROPERTY OF APPLE INC. THE POSSESSOR AGREES TO THE FOLLOWING:		PAGE 31 OF 102
I TO MAINTAIN THIS DOCUMENT IN CONFIDENCE		SHEET 21 OF 46
II NOT TO REPRODUCE OR COPY IT		
III NOT TO REVEAL OR PUBLISH IT IN WHOLE OR PART		
IV ALL RIGHTS RESERVED		



# BASEBAND PMU (2 OF 2)

CONFIDENTIAL AND PROPRIETARY APPLE SYSTEM DESIGN. FOR REFERENCE PURPOSES ONLY - NOT A CHANGE REQUEST.

BOARD_ID	REVISION
0.25V	N41 PROTO 1
0.50V	N41 PROTO 2, X122 RF DEV 1
0.70V	N41 PROTO 3, X122 PROTO 0
0.90V	N41 EVT 1, X122 PROTO 1
1.10V	N41 EVT 2, X122 EVT
1.30V	N41 EVT 3, X122 DVT

PA_ID	PA CONFIG
0.25V	B4/17 CONFIG 0
0.50V	B4_17 CONFIG 1
1.10V	B3/13 CONFIG 0

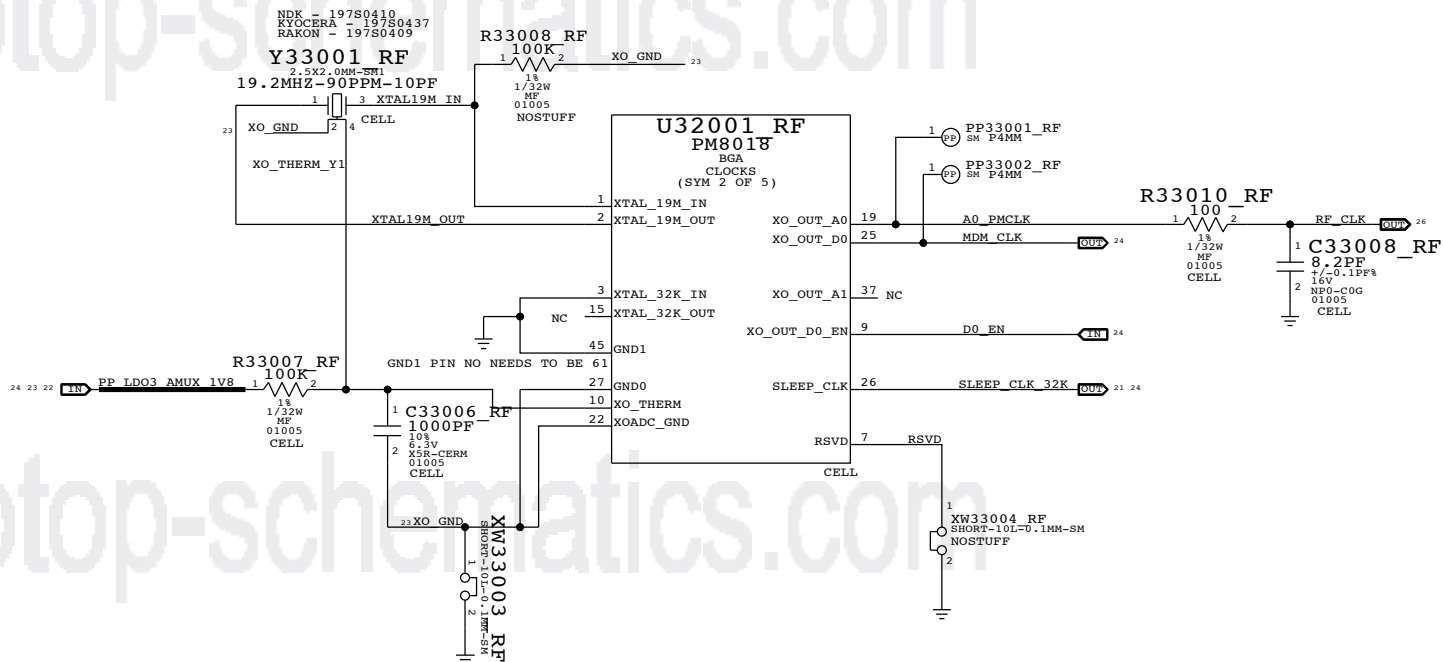
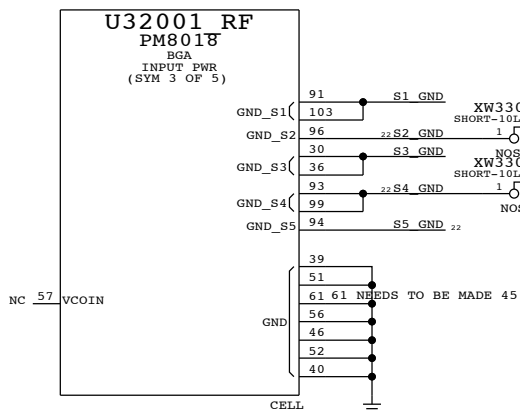
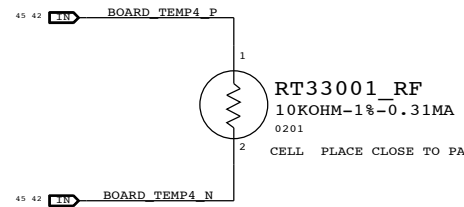
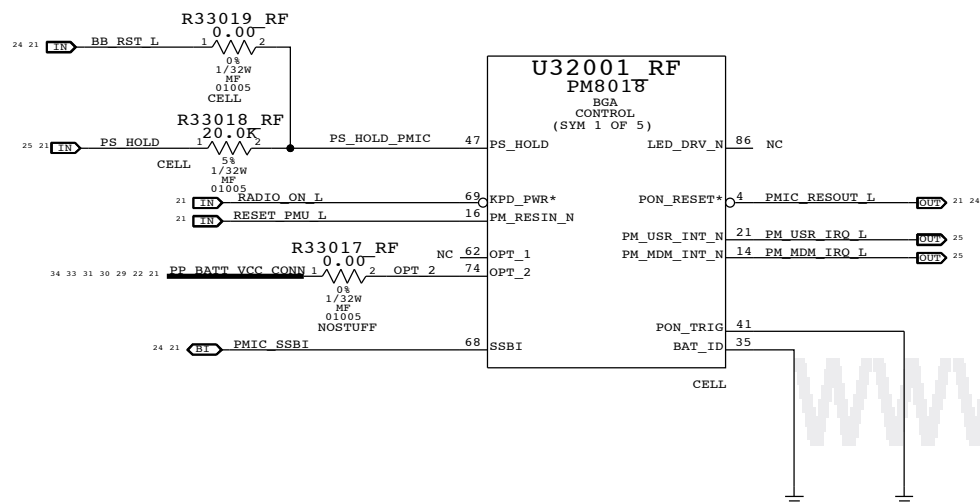
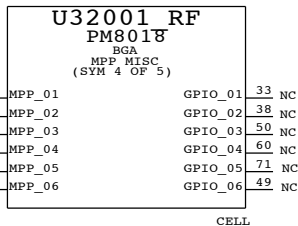
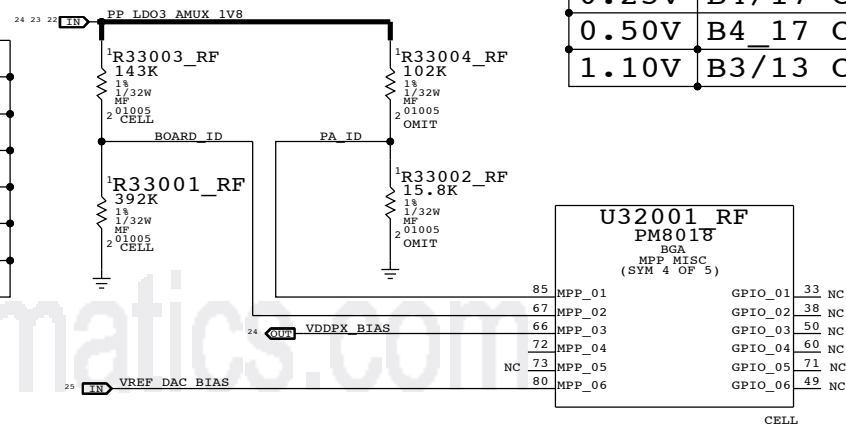

## ALTERNATES

PART NUMBER	ALTERNATE FOR PART NUMBER	BOM OPTION	REF DES	COMMENTS:
19780437	19780410	CELL	Y33001_RF	KYOCERA CRYSTAL
19780409	19780410	CELL	Y33001_RF	RAKON CRYSTAL

## BOM OPTIONS

PART#	QTY	DESCRIPTION	REFERENCE DESIGNATOR(S)	CRITICAL	BOM OPTION
11880685	1	PA_ID RES DIVIDER 102K	R33004_RF	Y	B4_17
11880656	1	PA_ID RES DIVIDER 61.9K	R33004_RF	Y	B3_13
11880729	1	PA_ID RES DIVIDER 39K	R33002_RF	Y	B4_17
11880685	1	PA_ID RES DIVIDER 102K	R33002_RF	Y	B3_13

R R317  
C C309  
L LXXX  
U U301  
XW XW305

PAGE TITLE	
BASEBAND PMU (2 OF 2)	
Apple Inc.	DRAWING NUMBER 051-9374
REVISION 13.0.0	SIZE D
NOTICE OF PROPRIETARY PROPERTY:	BRANCH
THE INFORMATION CONTAINED HEREIN IS THE PROPRIETARY PROPERTY OF APPLE INC. THE POSSESSOR AGREES TO THE FOLLOWING:	PAGE 33 OF 102
I TO MAINTAIN THIS DOCUMENT IN CONFIDENCE	SHEET 23 OF 46
II NOT TO REPRODUCE OR COPY IT	
III NOT TO REVEAL OR PUBLISH IT IN WHOLE OR PART	
IV ALL RIGHTS RESERVED	



# BASEBAND (2 OF 2)

CONFIDENTIAL AND PROPRIETARY APPLE SYSTEM DESIGN. FOR REFERENCE PURPOSES ONLY - NOT A CHANGE REQUEST.

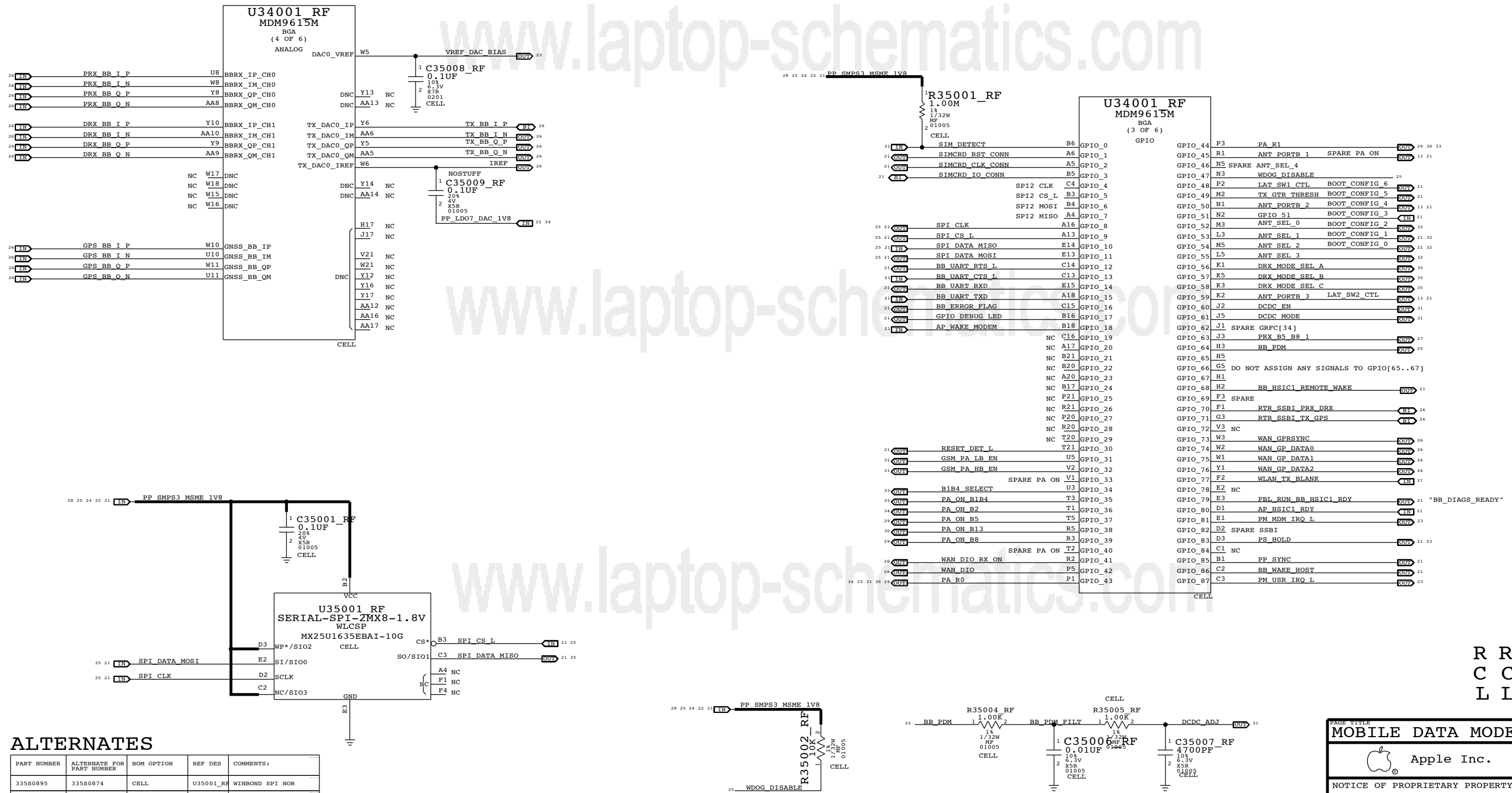

ALTERNATES				
PART NUMBER	ALTERNATE FOR PART NUMBER	BOM OPTION	REF DES	COMMENTS:
33580895	33580874	CELL	U35001_RF	WINBOND SPI NOR
33580899	33580874	CELL	U35001_RF	MICRON SPI NOR

R R608  
C C609  
L L601

MOBILE DATA MODEM (2 OF 2)	
Apple Inc.	DRAWING NUMBER: 051-9374
REVISION: 13.0.0	SIZE: D
NOTICE OF PROPRIETARY PROPERTY:	
THE INFORMATION CONTAINED HEREIN IS THE PROPRIETARY PROPERTY OF APPLE INC. THE POSSESSOR AGREES TO THE FOLLOWING:	
I TO MAINTAIN THIS DOCUMENT IN CONFIDENCE	
II NOT TO REPRODUCE OR COPY IT	
III NOT TO REVEAL OR PUBLISH IT IN WHOLE OR PART	
IV ALL RIGHTS RESERVED	
PAGE: 35 OF 102	SHEET: 25 OF 46

# RF TRANSCEIVER (1 OF 3)

CONFIDENTIAL AND PROPRIETARY APPLE SYSTEM DESIGN. FOR REFERENCE PURPOSES ONLY - NOT A CHANGE REQUEST.

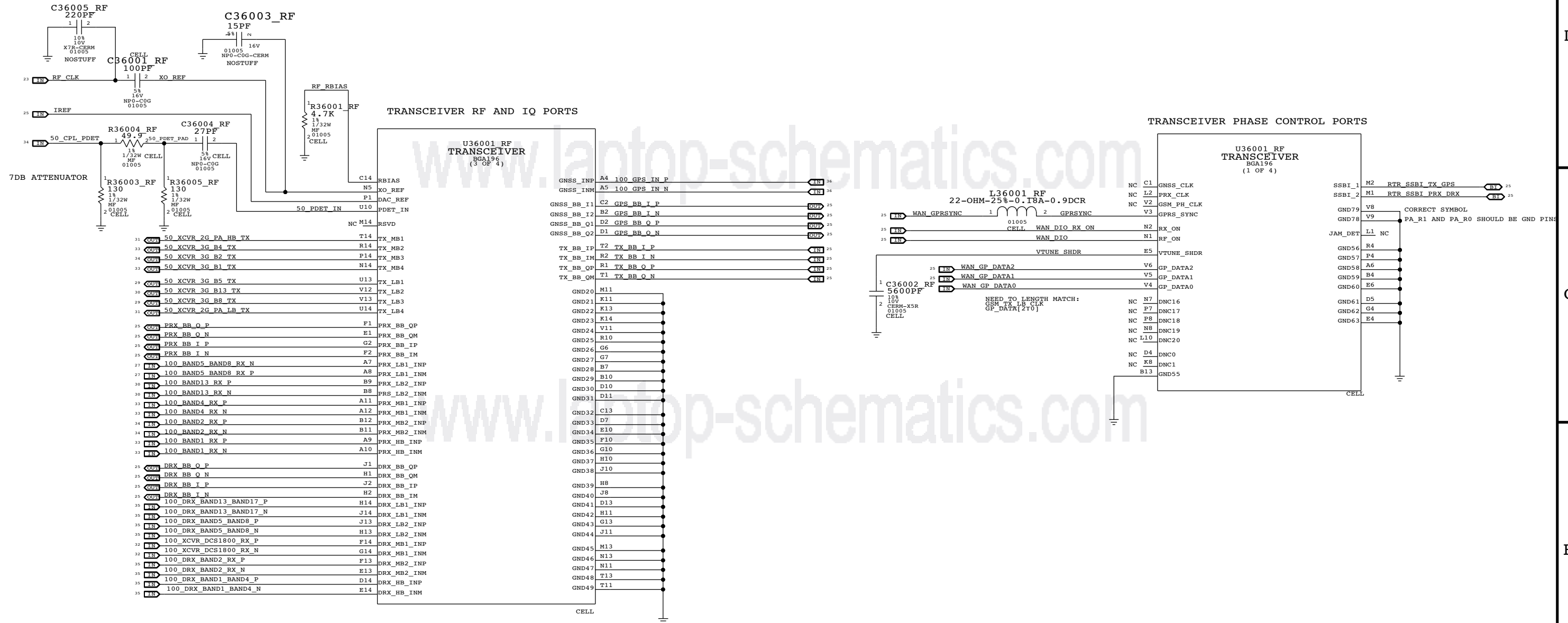

R R705  
C C705  
L LXXX  
U U701

PAGE TITLE		DRAWING NUMBER	SIZE
RF TRANSCEIVER (1 OF 3)		051-9374	D
Apple Inc.		REVISION	13.0.0
NOTICE OF PROPRIETARY PROPERTY:		BRANCH	
THE INFORMATION CONTAINED HEREIN IS THE PROPRIETARY PROPERTY OF APPLE INC. THE POSSESSOR AGREES TO THE FOLLOWING:		PAGE	36 OF 102
I TO MAINTAIN THIS DOCUMENT IN CONFIDENCE		SHEET	26 OF 46
II NOT TO REPRODUCE OR COPY IT			
III NOT TO REVEAL OR PUBLISH IT IN WHOLE OR PART			
IV ALL RIGHTS RESERVED			

# RF TRANSCEIVER SWITCHING NETWORKS (2 OF 3)

CONFIDENTIAL AND PROPRIETARY APPLE SYSTEM DESIGN. FOR REFERENCE PURPOSES ONLY - NOT A CHANGE REQUEST.

www.laptop-schematics.com

## BAND 5/BAND 8 PRX TRANSCEIVER SWITCH

### XM0830SZ SWITCH LOGIC

PRX_B5_B8	ACTIVE BAND	PORT
HIGH	5	PORT 1 TO PORT 3
LOW	8	PORT 1 TO PORT 2

SWAPPED BAND5 AND BAND8 INPUTS FROM DEV0

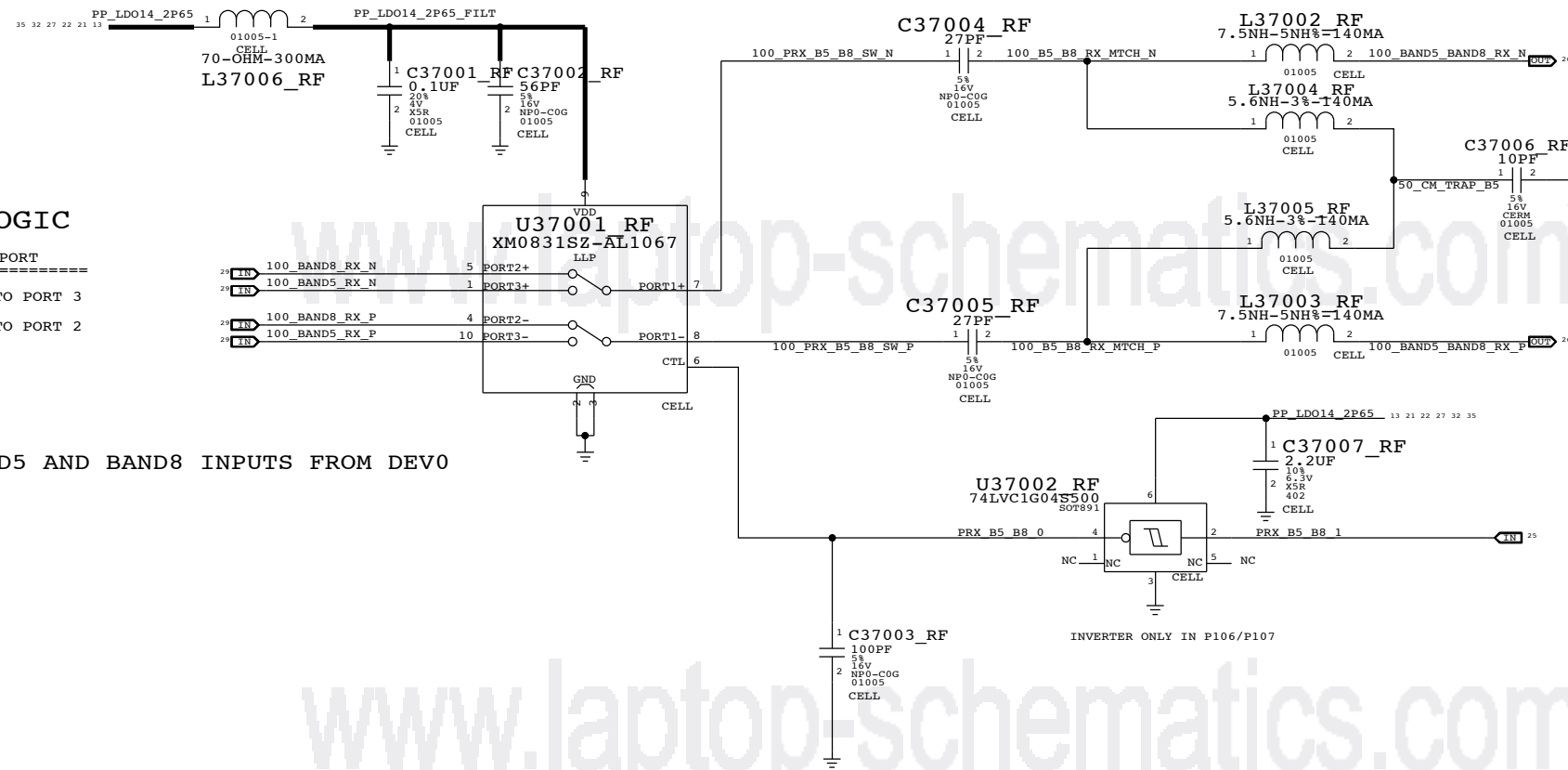

R RXXX  
C C37007  
L L803  
U U801

PAGE TITLE		
RF TRANSCEIVER (2 OF 3)		
Apple Inc.	DRAWING NUMBER	SIZE
	051-9374	D
	REVISION	
	13.0.0	
NOTICE OF PROPRIETARY PROPERTY:		
THE INFORMATION CONTAINED HEREIN IS THE PROPRIETARY PROPERTY OF APPLE INC. THE POSSESSOR AGREES TO THE FOLLOWING:		
I TO MAINTAIN THIS DOCUMENT IN CONFIDENCE	BRANCH	
II NOT TO REPRODUCE OR COPY IT	PAGE	37 OF 102
III NOT TO REVEAL OR PUBLISH IT IN WHOLE OR PART	SHEET	27 OF 46
IV ALL RIGHTS RESERVED		



# BAND 5/8 PAD

CONFIDENTIAL AND PROPRIETARY APPLE SYSTEM DESIGN. FOR REFERENCE PURPOSES ONLY - NOT A CHANGE REQUEST.

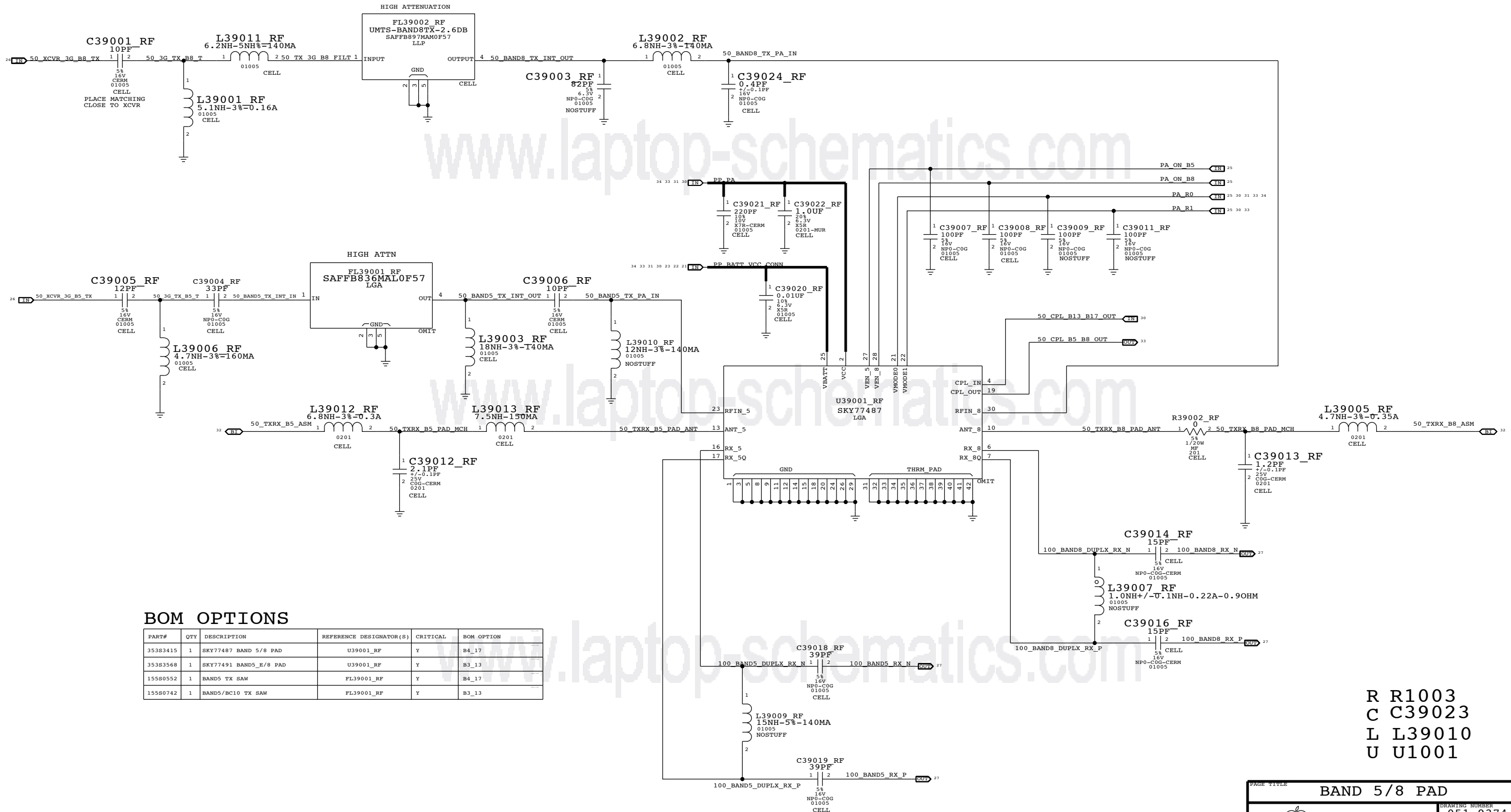

## BOM OPTIONS

PART#	QTY	DESCRIPTION	REFERENCE DESIGNATOR(S)	CRITICAL	BOM OPTION
353S3415	1	SKY77487 BAND 5/8 PAD	U39001_RF	Y	B4_17
353S3568	1	SKY77491 BAND5_E/8 PAD	U39001_RF	Y	B3_13
155S0552	1	BAND5 TX SAW	FL39001_RF	Y	B4_17
155S0742	1	BAND5/BC10 TX SAW	FL39001_RF	Y	B3_13

R R1003  
C C39023  
L L39010  
U U1001

PAGE TITLE		BAND 5/8 PAD	
Apple Inc.	DRAWING NUMBER	051-9374	SIZE D
	REVISION	13.0.0	
NOTICE OF PROPRIETARY PROPERTY: THE INFORMATION CONTAINED HEREIN IS THE PROPRIETARY PROPERTY OF APPLE INC. THE POSSESSOR AGREES TO THE FOLLOWING: I TO MAINTAIN THIS DOCUMENT IN CONFIDENCE II NOT TO REPRODUCE OR COPY IT III NOT TO REVEAL OR PUBLISH IT IN WHOLE OR PART IV ALL RIGHTS RESERVED		BRANCH	
		PAGE	39 OF 102
		SHEET	29 OF 46

# B13/17 INTERSTAGE, PA, AND DUPLEXER

CONFIDENTIAL AND PROPRIETARY APPLE SYSTEM DESIGN. FOR REFERENCE PURPOSES ONLY - NOT A CHANGE REQUEST.

D

D

C

C

B

B

A

A

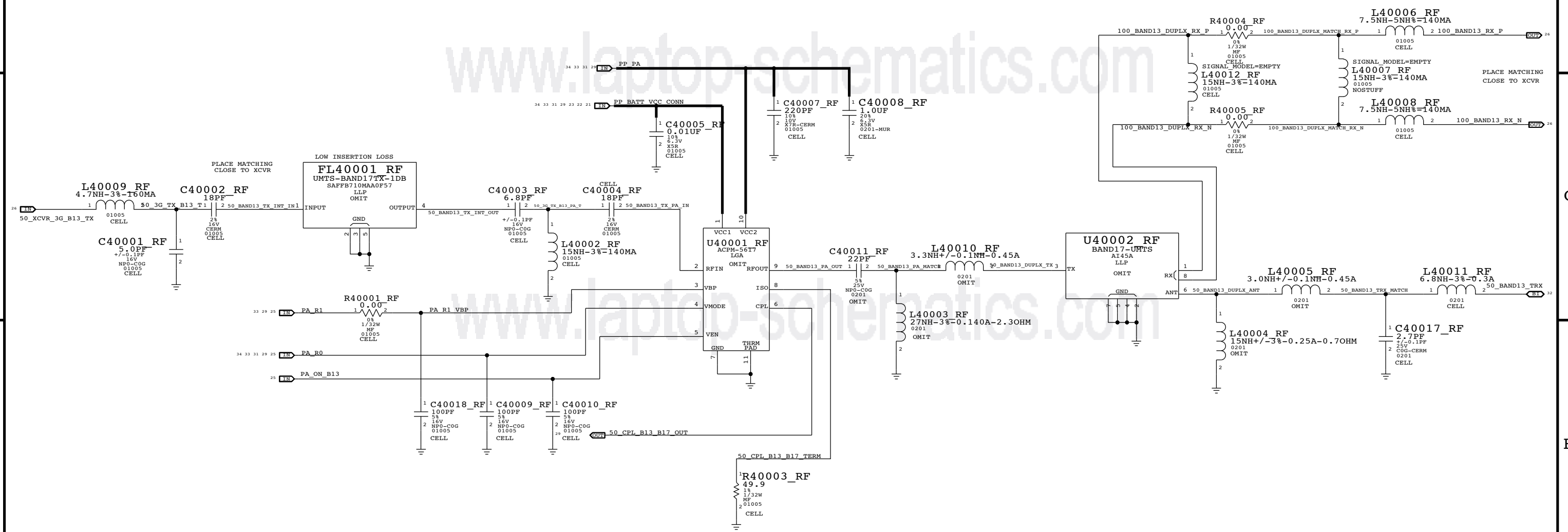

## BOM OPTIONS

PART#	QTY	DESCRIPTION	REFERENCE DESIGNATOR(S)	CRITICAL	BOM OPTION
15580620	1	BAND17 TX SAW	FL40001_RF	Y	B4_17
15580619	1	BAND13 TX SAW	FL40001_RF	Y	B3_13
35383567	1	BAND17 PAM - SKY77729	U40001_RF	Y	B4_17
35383441	1	BAND13 PAM - AVAGO ACPM-5613	U40001_RF	Y	B3_13
15580709	1	BAND17 DUPLEXER	U40002_RF	Y	B4_17
15580738	1	BAND13 DUPLEXER	U40002_RF	Y	B3_13
15281280	1	5.1 NH INDUCTOR, 0201	C40011_RF	Y	B4_17
13180129	1	22 PF CAPACITOR, 0201	C40011_RF	Y	B3_13
13180198	1	1.8 PF CAPACITOR, 0201	L40003_RF	Y	B4_17
11780002	1	0 OHMS RESISTOR, 0201	L40010_RF	Y	B4_17
15281284	1	3.3 NH INDUCTOR, 0201	L40010_RF	Y	B3_13
15281336	1	8.2 NH INDUCTOR, 0201	L40004_RF	Y	B4_17
15281342	1	15 NH INDUCTOR, 0201	L40004_RF	Y	B3_13
15281063	1	2.2 NH INDUCTOR, 0201	L40005_RF	Y	B4_17
15281222	1	3.0 NH INDUCTOR, 0201	L40005_RF	Y	B3_13

## PA POWER MODES

MODE	PA_R0	PA_R1
LOW	HIGH	HIGH
MEDIUM	LOW	HIGH
HIGH	LOW	LOW

FLFL1101  
R R1102  
C C1118  
L L1108  
U U1102

PAGE TITLE		BAND 13 PA	
Apple Inc.		DRAWING NUMBER	051-9374
		REVISION	13.0.0
NOTICE OF PROPRIETARY PROPERTY:		PAGE	
THE INFORMATION CONTAINED HEREIN IS THE PROPRIETARY PROPERTY OF APPLE INC. THE POSSESSOR AGREES TO THE FOLLOWING:		40 OF 102	
I TO MAINTAIN THIS DOCUMENT IN CONFIDENCE		PAGE	
II NOT TO REPRODUCE OR COPY IT		30 OF 46	
III NOT TO REVEAL OR PUBLISH IT IN WHOLE OR PART			
IV ALL RIGHTS RESERVED			

# 2G PA, PA DC/DC CONVERTER

CONFIDENTIAL AND PROPRIETARY APPLE SYSTEM DESIGN. FOR REFERENCE PURPOSES ONLY - NOT A CHANGE REQUEST.

## 2G PA GAIN MODES

BAND	MODE	GAIN MODE	PA R1	PCL RANGE
LOW BAND	GSM	ULTRA LOW	HIGH	16 TO 19
LOW BAND	GSM	LOW	HIGH	14 TO 15
LOW BAND	GSM	MEDIUM	LOW	7 TO 13
LOW BAND	GSM	HIGH	LOW	5 TO 6
HIGH BAND	GSM	ULTRA LOW	HIGH	10 TO 15
HIGH BAND	GSM	LOW	HIGH	7 TO 9
HIGH BAND	GSM	HIGH	LOW	0 TO 6
LOW BAND	EDGE	LOW	HIGH	15 TO 19
LOW BAND	EDGE	MEDIUM	LOW	10 TO 14
LOW BAND	EDGE	HIGH	LOW	8 TO 9
HIGH BAND	EDGE	LOW	HIGH	9 TO 15
HIGH BAND	EDGE	HIGH	LOW	2 TO 8

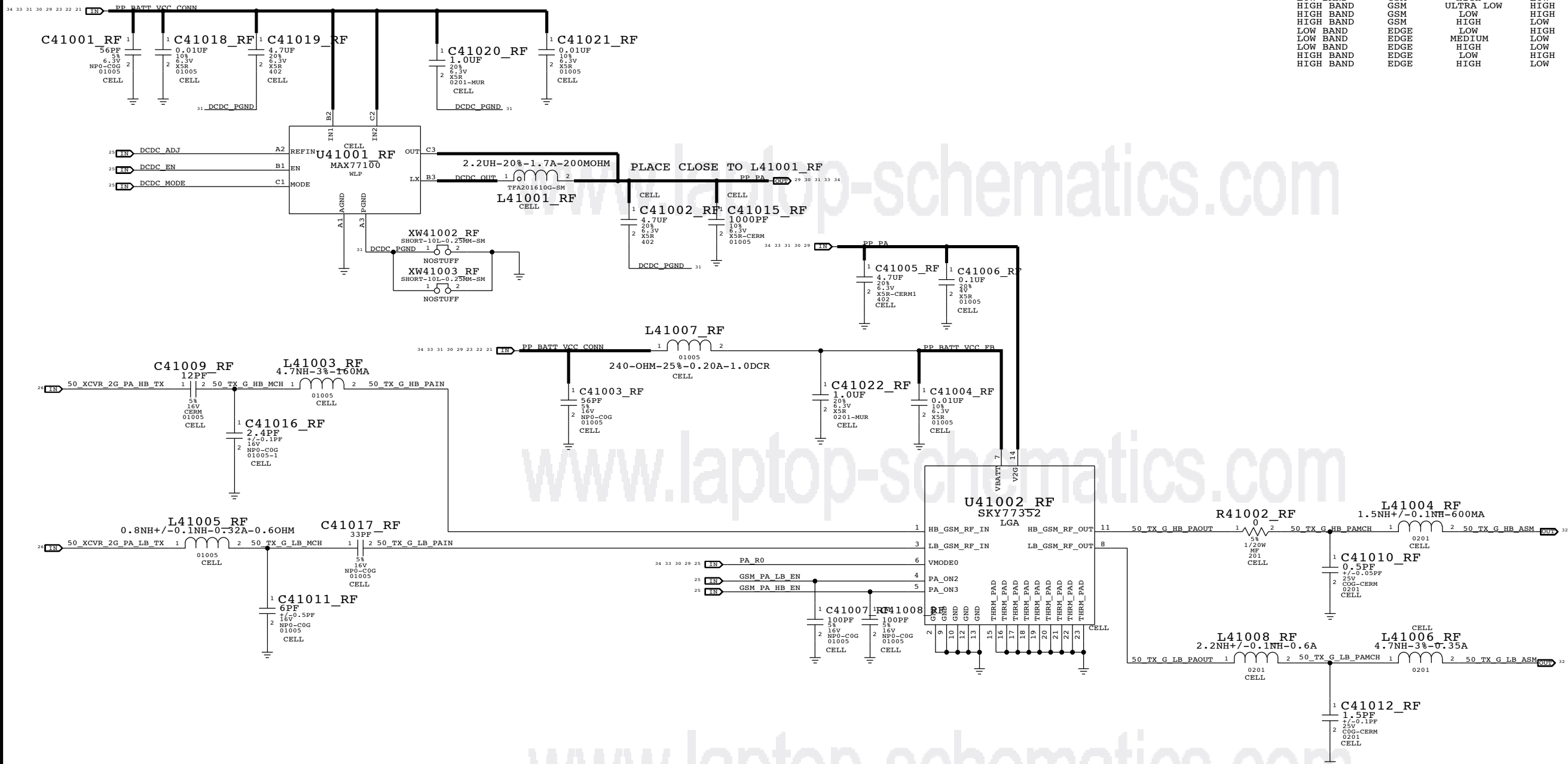

R R1209  
C C1215  
L L41007  
U U1202

PAGE TITLE		DRAWING NUMBER	SIZE
2G PA, DCDC CONVERTER		051-9374	D
Apple Inc.		REVISION	13.0.0
NOTICE OF PROPRIETARY PROPERTY:		BRANCH	
THE INFORMATION CONTAINED HEREIN IS THE PROPRIETARY PROPERTY OF APPLE INC. THE POSSESSOR AGREES TO THE FOLLOWING:		PAGE	41 OF 102
I TO MAINTAIN THIS DOCUMENT IN CONFIDENCE		SHEET	31 OF 46
II NOT TO REPRODUCE OR COPY IT			
III NOT TO REVEAL OR PUBLISH IT IN WHOLE OR PART			
IV ALL RIGHTS RESERVED			

# ASM, DCS RX

CONFIDENTIAL AND PROPRIETARY APPLE SYSTEM DESIGN. FOR REFERENCE PURPOSES ONLY - NOT A CHANGE REQUEST.

www.laptop-schematics.com

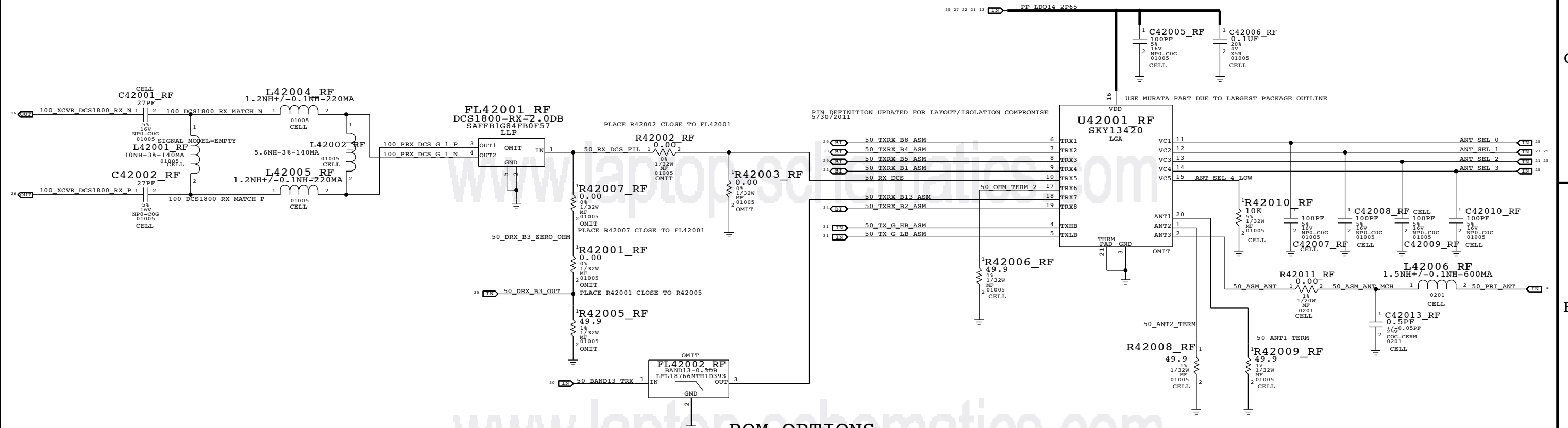

## BOM OPTIONS

PART#	QTY	DESCRIPTION	REFERENCE DESIGNATOR(S)	CRITICAL	BOM OPTION
15580596	1	DCS1800 RX FIL	FL42001_RF	Y	B4_17
15580729	1	BAND3 RX FIL	FL42001_RF	Y	B3_13
15580695	1	THRU LINE	FL42002_RF	Y	B4_17
15580722	1	BAND13 TX LFP	FL42002_RF	Y	B3_13
11780161	1	0OHM RES	R42001_RF	Y	B3_13
11780161	1	0OHM RES	R42002_RF	Y	B4_17
11880652	1	49.9OHM RES	R42003_RF	Y	B3_13
11880652	1	49.9OHM RES	R42005_RF	Y	B4_17
11780161	1	0OHM RES	R42007_RF	Y	B3_13
35383573	1	ASM, SKYWORKS	U42001_RF	Y	B4_17
35383573	1	ASM, SKYWORKS	U42001_RF	Y	B3_13

R R42011  
C C42013  
L 42006  
U U1301  
FL FL1302

PAGE TITLE		DRAWING NUMBER	SIZE
DCS RX, ASM		051-9374	D
Apple Inc.		REVISION	13.0.0
NOTICE OF PROPRIETARY PROPERTY:		BRANCH	
THE INFORMATION CONTAINED HEREIN IS THE PROPRIETARY PROPERTY OF APPLE INC. THE POSSESSOR AGREES TO THE FOLLOWING:		PAGE	42 OF 102
I TO MAINTAIN THIS DOCUMENT IN CONFIDENCE		SHEET	32 OF 46
II NOT TO REPRODUCE OR COPY IT			
III NOT TO REVEAL OR PUBLISH IT IN WHOLE OR PART			
IV ALL RIGHTS RESERVED			

# BAND 1/4 PAD

CONFIDENTIAL AND PROPRIETARY APPLE SYSTEM DESIGN. FOR REFERENCE PURPOSES ONLY - NOT A CHANGE REQUEST.

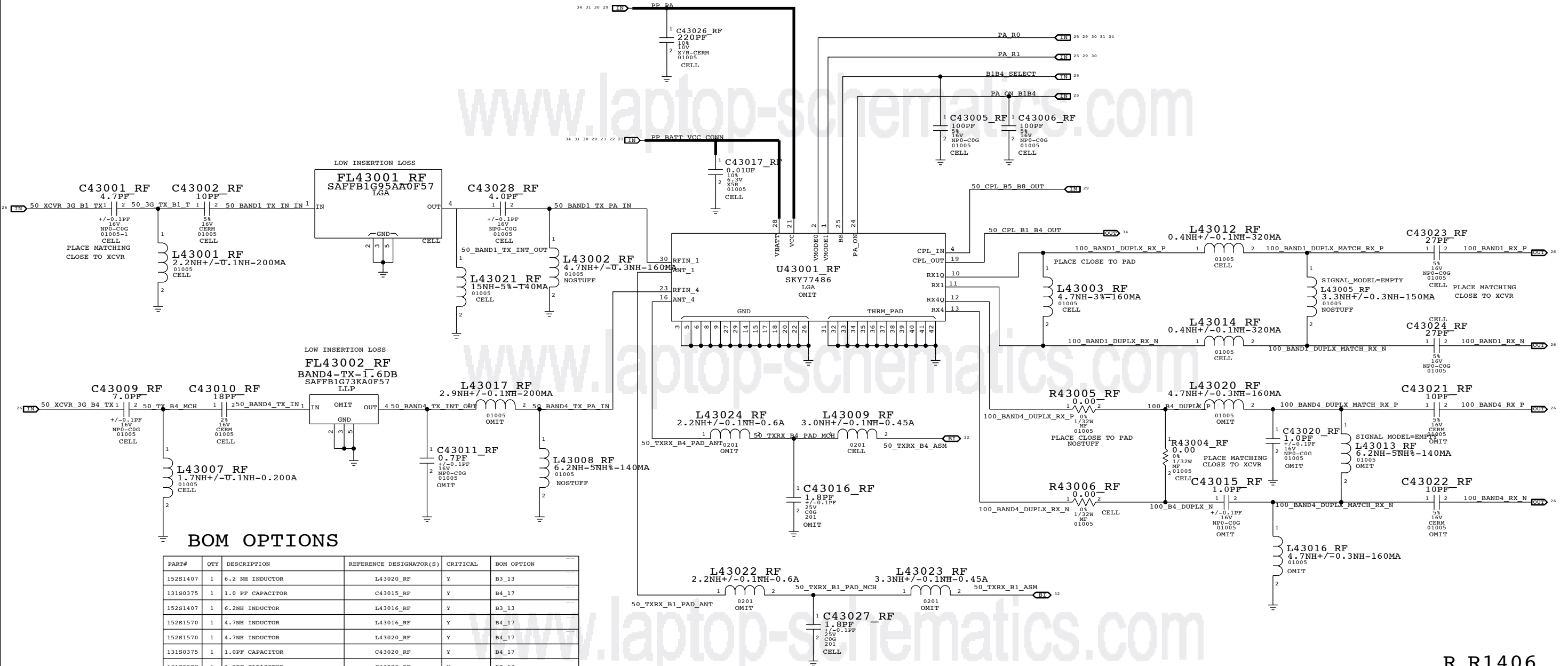

## BOM OPTIONS

PART#	QTY	DESCRIPTION	REFERENCE DESIGNATOR(S)	CRITICAL	BOM OPTION
15281407	1	6.2 NH INDUCTOR	L43020_RF	Y	B3_13
13180375	1	1.0 PF CAPACITOR	C43015_RF	Y	B4_17
15281407	1	6.2NH INDUCTOR	L43016_RF	Y	B3_13
15281570	1	4.7NH INDUCTOR	L43016_RF	Y	B4_17
15281570	1	4.7NH INDUCTOR	L43020_RF	Y	B4_17
13180375	1	1.0PF CAPACITOR	C43020_RF	Y	B4_17
13180377	1	1.2PF CAPACITOR	C43020_RF	Y	B3_13
13180377	1	1.2PF CAPACITOR	C43015_RF	Y	B3_13
13180377	1	1.2 PF CAPACITOR	C43011_RF	Y	B4_17
15281571	1	5.6 NH INDUCTOR	C43011_RF	Y	B3_13
15281567	1	3.3 NH INDUCTOR	L43017_RF	Y	B4_17
13180215	1	22 PF CAPACITOR	L43017_RF	Y	B3_13
13180198	1	1.8 PF CAPACITOR	C43016_RF	Y	B4_17
13180337	1	1.5 PF CAPACITOR	C43016_RF	Y	B3_13
15281407	1	6.2NH INDUCTOR	L43013_RF	Y	B4_17
15281571	1	5.6NH INDUCTOR	L43013_RF	Y	B3_13
13180219	1	10PF CAPACITOR	C43021_RF	Y	B4_17
13180219	1	10PF CAPACITOR	C43022_RF	Y	B4_17
13180307	1	100PF CAPACITOR	C43021_RF	Y	B3_13
13180307	1	100PF CAPACITOR	C43022_RF	Y	B3_13

## BOM OPTIONS

PART#	QTY	DESCRIPTION	REFERENCE DESIGNATOR(S)	CRITICAL	BOM OPTION
35383255	1	B1/4 PAD, AVAGO AFEM-7814	U43001_RF	Y	B4_17
35383443	1	B1/3 PAD, AVAGO AFEM-7813	U43001_RF	Y	B3_13
15580590	1	B4 TX FIL	FL43002_RF	Y	B4_17
15580712	1	B3 TX FIL	FL43002_RF	Y	B3_13
15281063	1	2.2NH INDUCTOR	L43022_RF	Y	B4_17
15281222	1	3.0NH INDUCTOR	L43022_RF	Y	B3_13
15281284	1	3.3NH INDUCTOR	L43023_RF	Y	B4_17
15281222	1	3.0NH INDUCTOR	L43023_RF	Y	B3_13
15281063	1	2.2NH INDUCTOR	L43024_RF	Y	B4_17
15281222	1	3.0NH INDUCTOR	L43024_RF	Y	B3_13

R R1406  
C C43027  
L L43018  
U U1401  
FL FL1101

PAGE TITLE		
<b>BAND 1/4 PAD</b>		
 Apple Inc.	DRAWING NUMBER	051-9374
	REVISION	13.0.0
NOTICE OF PROPRIETARY PROPERTY: THE INFORMATION CONTAINED HEREIN IS THE PROPRIETARY PROPERTY OF APPLE INC. THE POSSESSOR AGREES TO THE FOLLOWING: I TO MAINTAIN THIS DOCUMENT IN CONFIDENCE II NOT TO REPRODUCE OR COPY IT III NOT TO REVEAL OR PUBLISH IT IN WHOLE OR PART IV ALL RIGHTS RESERVED	BRANCH	
	PAGE	43 OF 102
	SHEET	33 OF 46

# BAND2 PAD

CONFIDENTIAL AND PROPRIETARY APPLE SYSTEM DESIGN. FOR REFERENCE PURPOSES ONLY - NOT A CHANGE REQUEST.

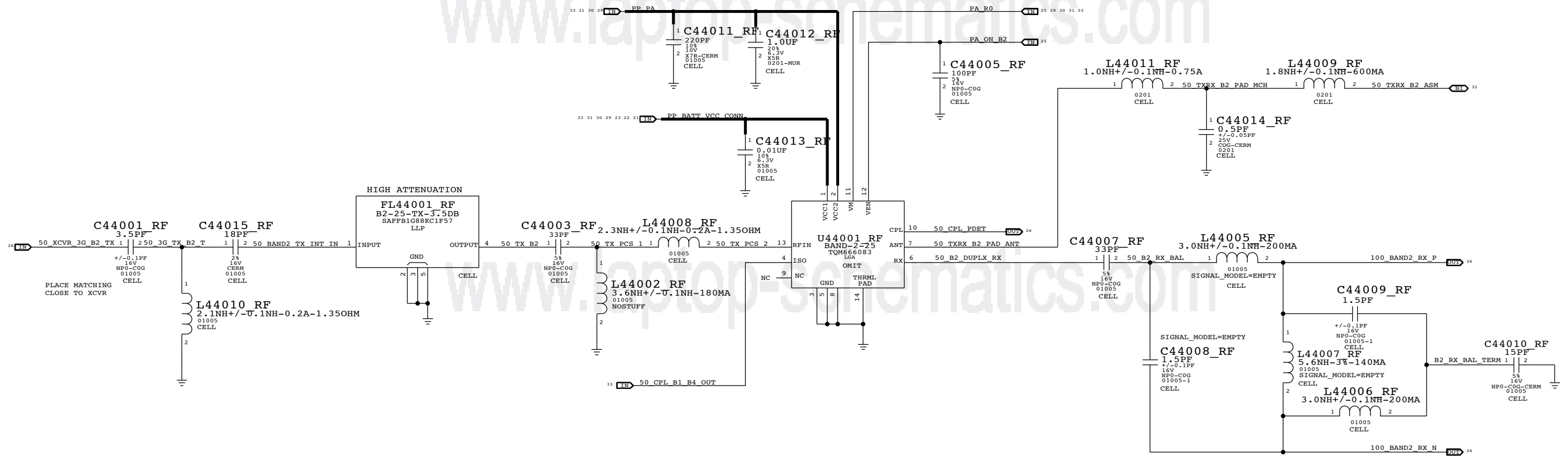

## BOM OPTIONS

PART#	QTY	DESCRIPTION	REFERENCE DESIGNATOR(S)	CRITICAL	BOM OPTION
35383715	1	B2 PAD, TRIQUINT B2 PAD	U44001_RF	Y	B4_17
35383459	1	B2 PAD, TRIQUINT B25 PAD	U44001_RF	Y	B3_13

R R1501  
 C C44014  
 L L1509  
 U U1501  
 FL FL1501

PAGE TITLE		
<b>BAND2 PAD</b>		
Apple Inc.	DRAWING NUMBER	SIZE
	051-9374	D
NOTICE OF PROPRIETARY PROPERTY:		
THE INFORMATION CONTAINED HEREIN IS THE PROPRIETARY PROPERTY OF APPLE INC. THE POSSESSOR AGREES TO THE FOLLOWING:		
I TO MAINTAIN THIS DOCUMENT IN CONFIDENCE	BRANCH	
II NOT TO REPRODUCE OR COPY IT	PAGE	44 OF 102
III NOT TO REVEAL OR PUBLISH IT IN WHOLE OR PART	SHEET	34 OF 46
IV ALL RIGHTS RESERVED		

# RX DIVERSITY

CONFIDENTIAL AND PROPRIETARY APPLE SYSTEM DESIGN. FOR REFERENCE PURPOSES ONLY - NOT A CHANGE REQUEST.

## DIVERSITY MODULE LOGIC

BAND VC1 VC2 VC3  
 =====  
 BAND 1/4  
 BAND 2  
 BAND 5  
 BAND 8  
 BAND 13/17

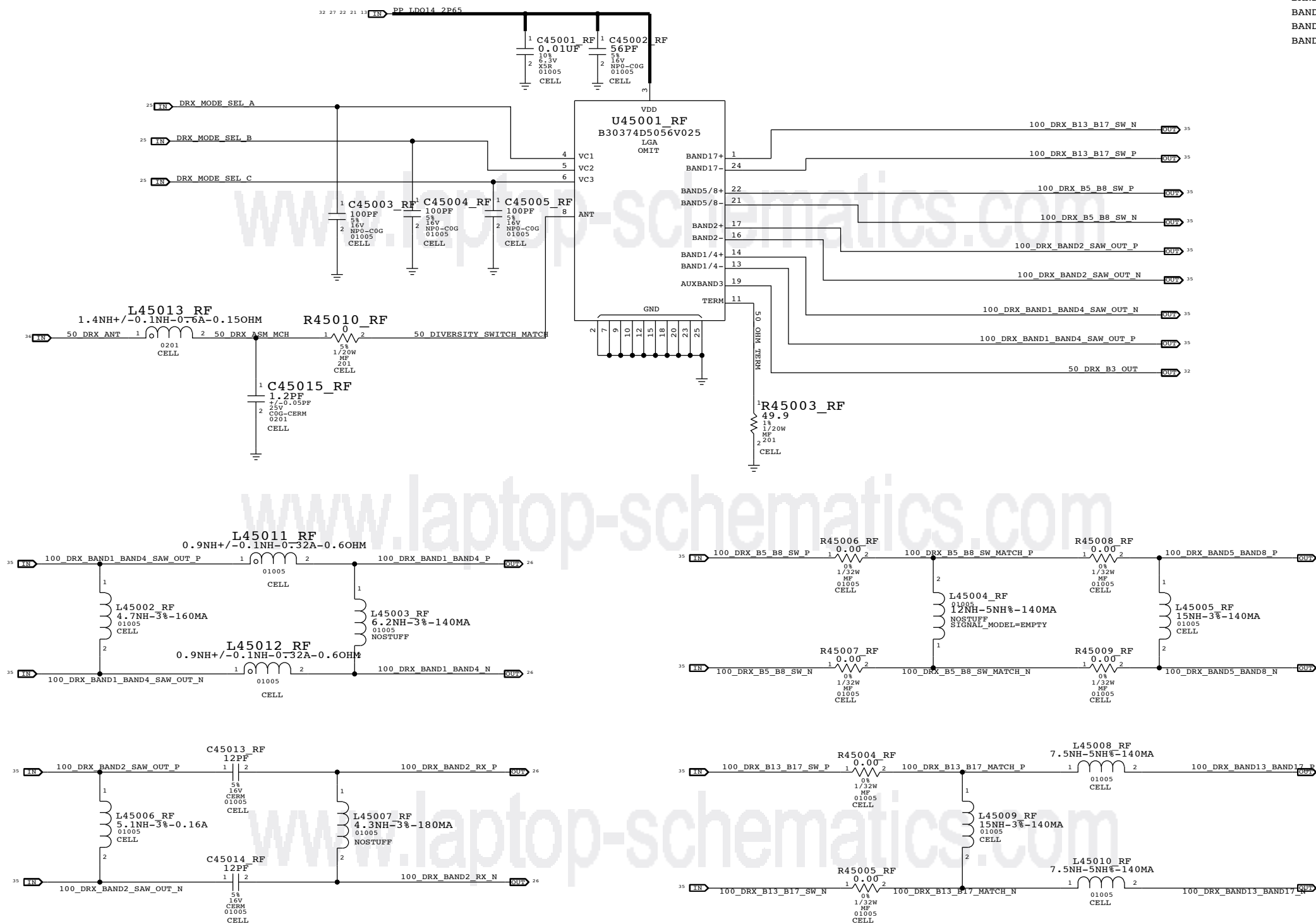

R R1603  
 C C1616  
 L L1610  
 U U1601

### BOM OPTIONS

PART#	QTY	DESCRIPTION	REFERENCE DESIGNATOR(S)	CRITICAL	BOM OPTION
35383538	1	EPCOS B17 DIVERSITY MODULE	U45001_RF	Y	B4_17
35383537	1	EPCOS B13/BC10 DIV. MODULE	U45001_RF	Y	B3_13

PAGE TITLE		RX DIVERSITY	
Apple Inc.	DRAWING NUMBER	051-9374	SIZE D
	REVISION	13.0.0	
NOTICE OF PROPRIETARY PROPERTY:		BRANCH	
THE INFORMATION CONTAINED HEREIN IS THE PROPRIETARY PROPERTY OF APPLE INC. THE POSSESSOR AGREES TO THE FOLLOWING:		PAGE	
I TO MAINTAIN THIS DOCUMENT IN CONFIDENCE		45 OF 102	
II NOT TO REPRODUCE OR COPY IT		SHEET	
III NOT TO REVEAL OR PUBLISH IT IN WHOLE OR PART		35 OF 46	
IV ALL RIGHTS RESERVED			

# GPS

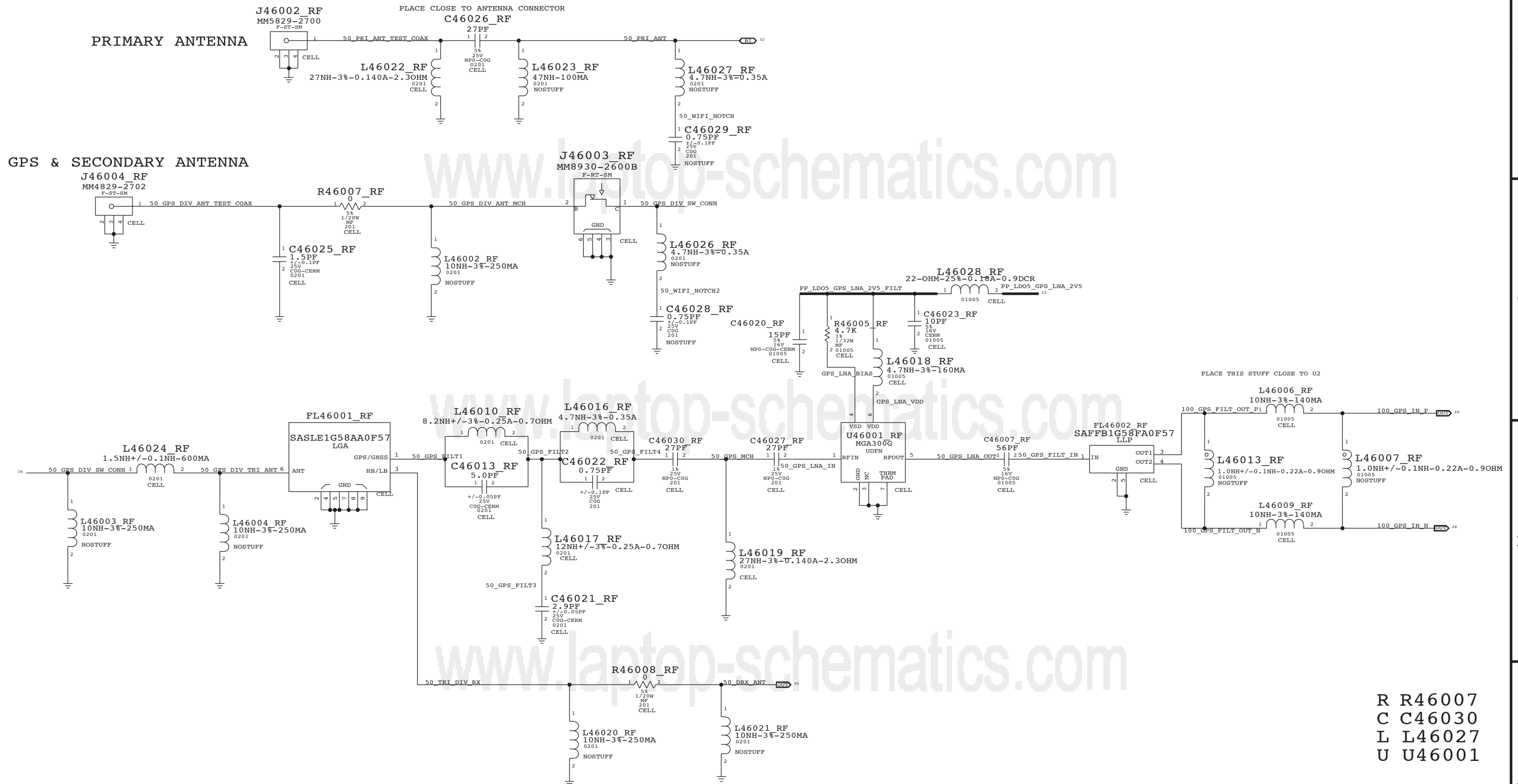

- R R46007
- C C46030
- L L46027
- U U46001

PAGE TITLE		GPS	
Apple Inc.	DRAWING NUMBER	051-9374	SIZE
	REVISION	13.0.0	
NOTICE OF PROPRIETARY PROPERTY:		BRANCH	
THE INFORMATION CONTAINED HEREIN IS THE PROPRIETARY PROPERTY OF APPLE INC. THE POSSESSOR AGREES TO THE FOLLOWING:		PAGE	
I TO MAINTAIN THIS DOCUMENT IN CONFIDENCE		46 OF 102	
II NOT TO REPRODUCE OR COPY IT		SHEET	
III NOT TO REVEAL OR PUBLISH IT IN WHOLE OR PART		36 OF 46	
IV ALL RIGHTS RESERVED			

# WLAN/BT

CONFIDENTIAL AND PROPRIETARY APPLE SYSTEM DESIGN. FOR REFERENCE PURPOSES ONLY - NOT A CHANGE REQUEST.

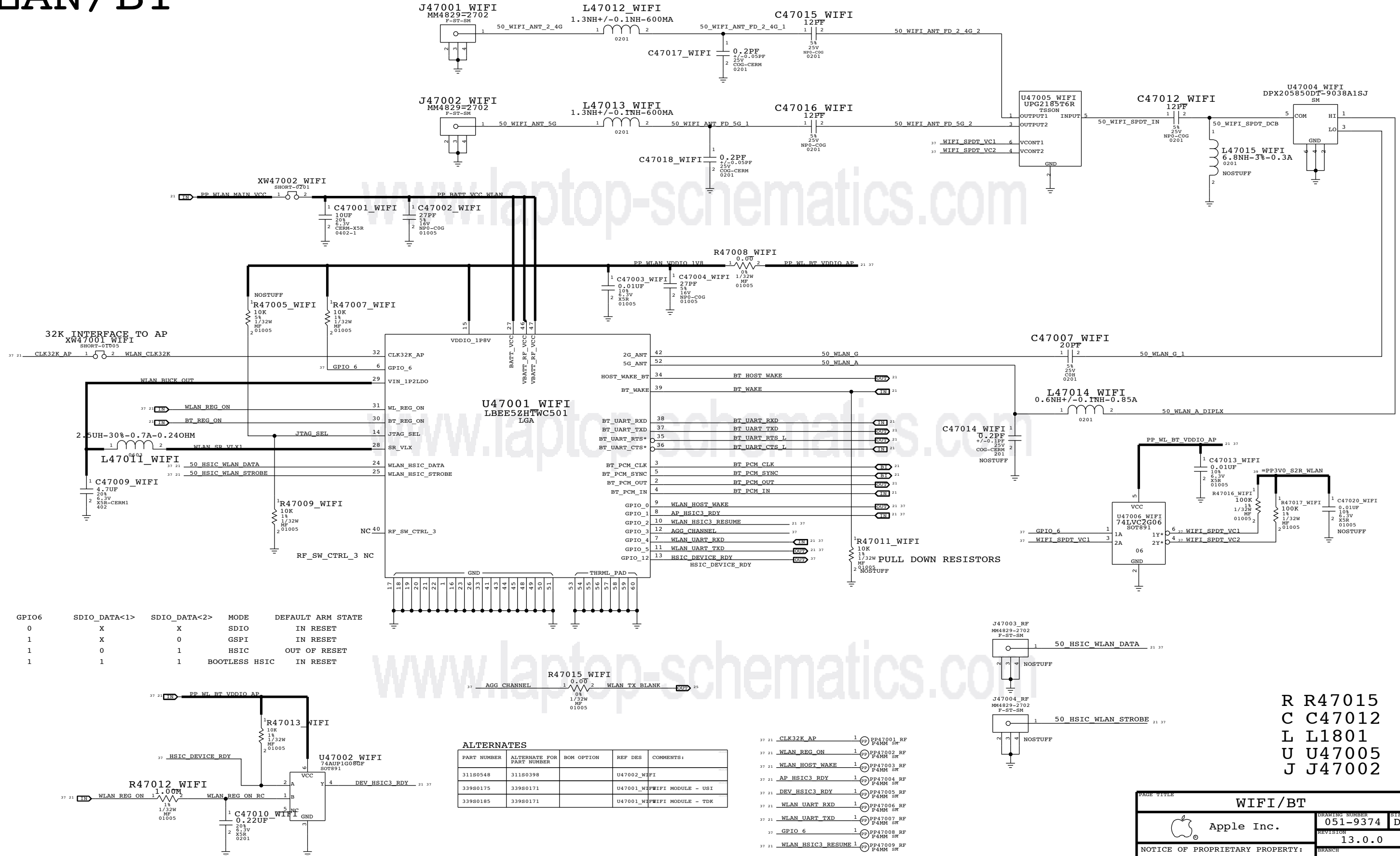

R R47015  
C C47012  
L L1801  
U U47005  
J J47002

PAGE TITLE		
<b>WIFI/BT</b>		
	DRAWING NUMBER	051-9374
	REVISION	13.0.0
NOTICE OF PROPRIETARY PROPERTY: THE INFORMATION CONTAINED HEREIN IS THE PROPRIETARY PROPERTY OF APPLE INC. THE POSSESSOR AGREES TO THE FOLLOWING: I TO MAINTAIN THIS DOCUMENT IN CONFIDENCE II NOT TO REPRODUCE OR COPY IT III NOT TO REVEAL OR PUBLISH IT IN WHOLE OR PART IV ALL RIGHTS RESERVED	BRANCH	
	PAGE	47 OF 102
	SHEET	37 OF 46

MOSFET	FDMC6676BZ
CHANNEL	P-TYPE
RDS(ON)	27 MOHM @-4.5V
IMAX	6.9 A
VGS MAX	+/- 25V

PRELIMINARY - PENDING SIMULATIONS WITH TRISTAR

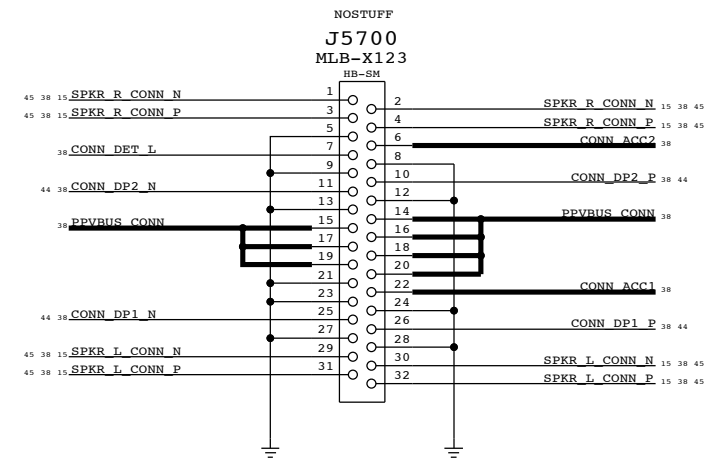

NOTE: SPKR\_L\_CONN\_N AND SPKR\_L\_CONN\_P WERE SWAPPED ON 5/22/12 PER RADAR #11526818

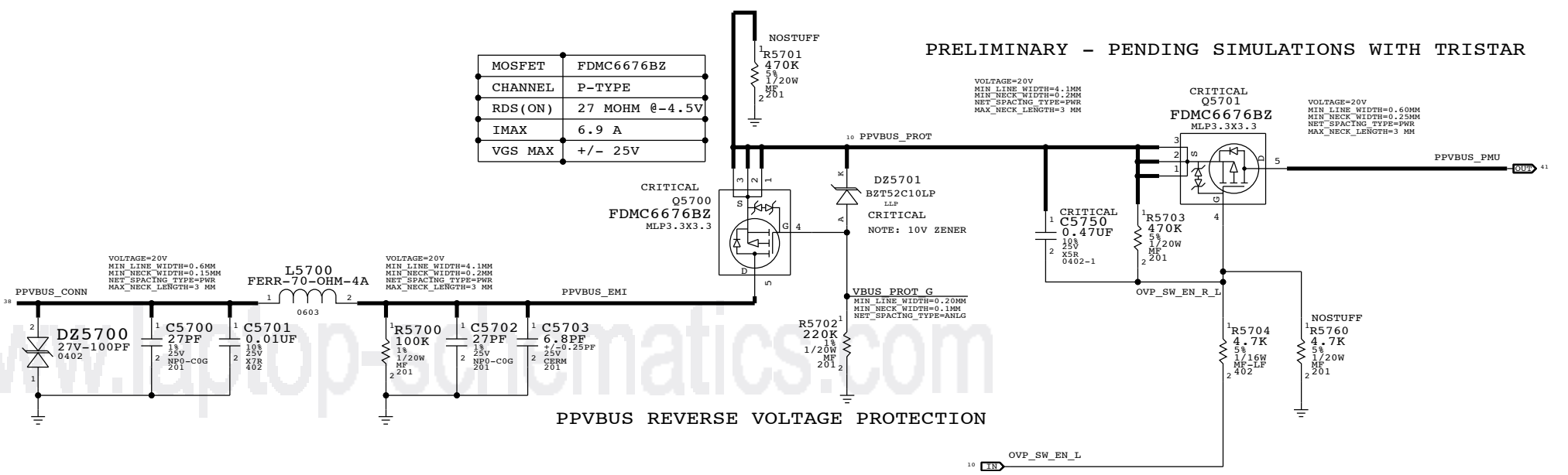

PPVBUS REVERSE VOLTAGE PROTECTION

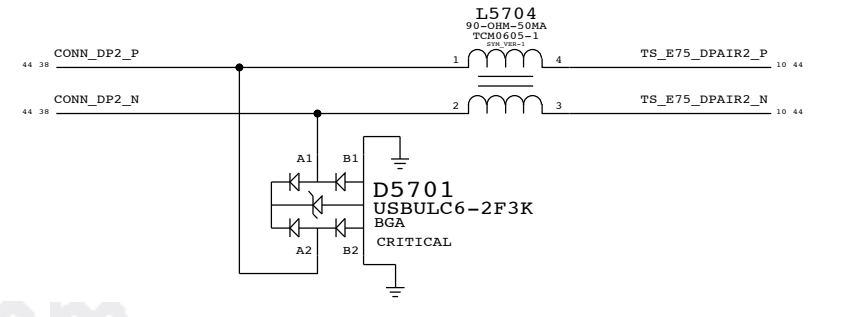
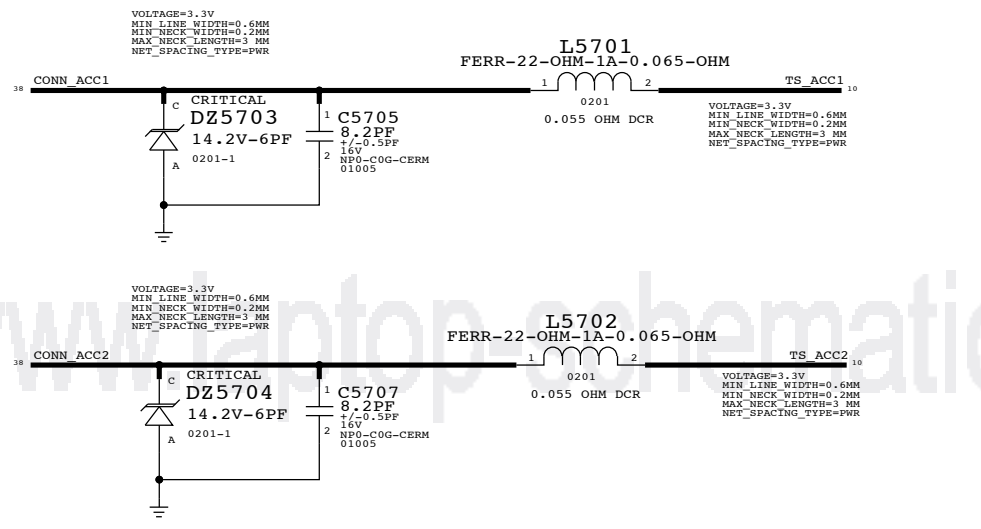
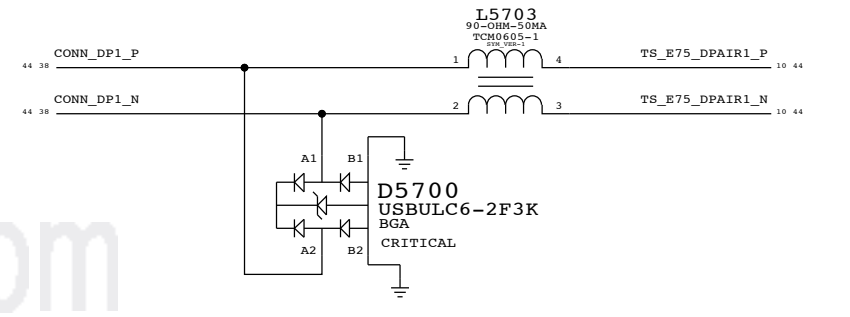
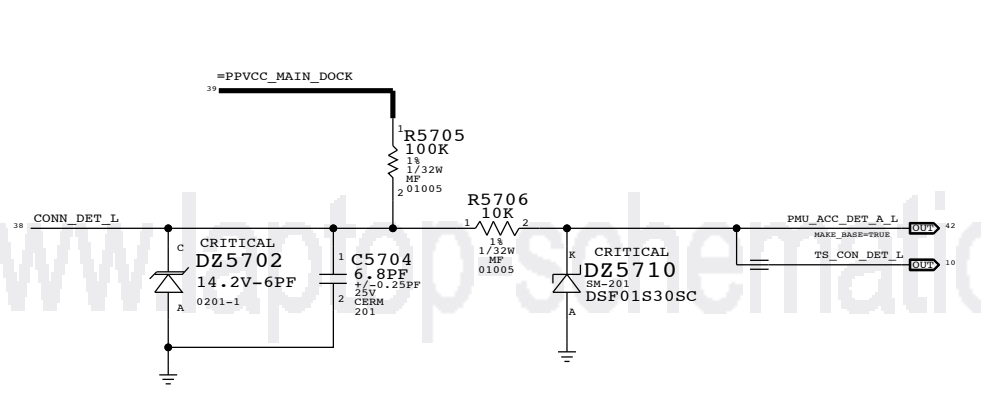

SYNC MASTER=N/A		SYNC DATE=04/18/2011	
PAGE TITLE <b>IO FLEX: DOCK COMPONENTS</b>			
Apple Inc.		DRAWING NUMBER 051-9374	SIZE D
		REVISION 13.0.0	
NOTICE OF PROPRIETARY PROPERTY: THE INFORMATION CONTAINED HEREIN IS THE PROPRIETARY PROPERTY OF APPLE INC. THE POSSESSOR AGREES TO THE FOLLOWING: I TO MAINTAIN THIS DOCUMENT IN CONFIDENCE II NOT TO REPRODUCE OR COPY IT III NOT TO REVEAL OR PUBLISH IT IN WHOLE OR PART IV ALL RIGHTS RESERVED			
		PAGE 57 OF 102	
		SHEET 38 OF 46	

# POWER CONN / ALIAS

## LDO RAILS

PROGRAMMABLE ON/OFF

## BUCK RAILS

## CHARGER MAIN

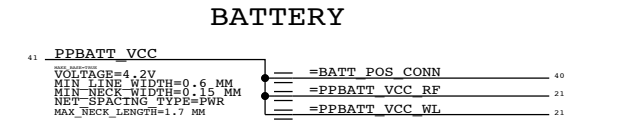
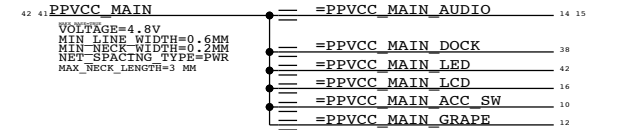
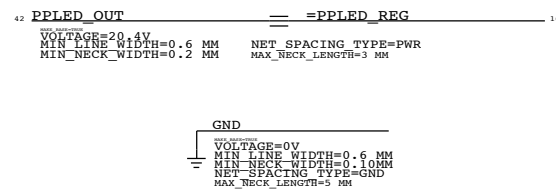
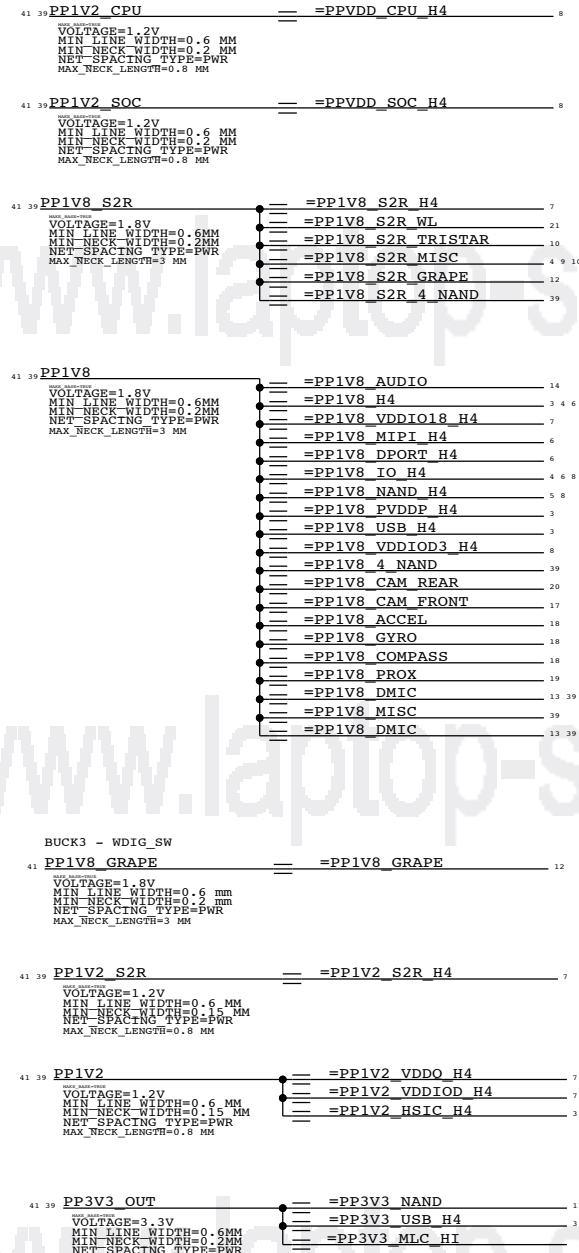

## BOOST->LDOS

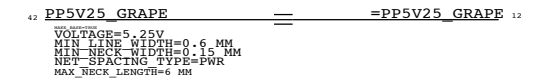

## DESENSE CAPS

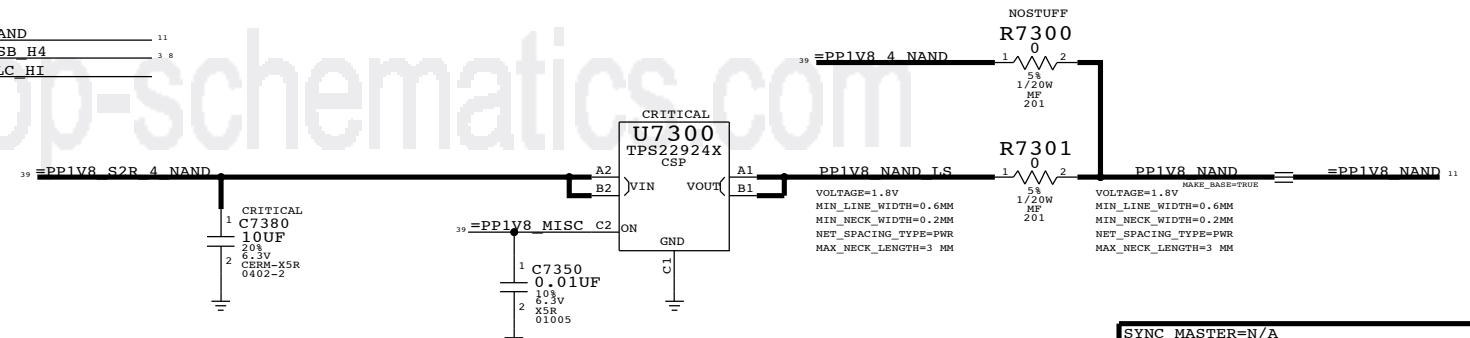
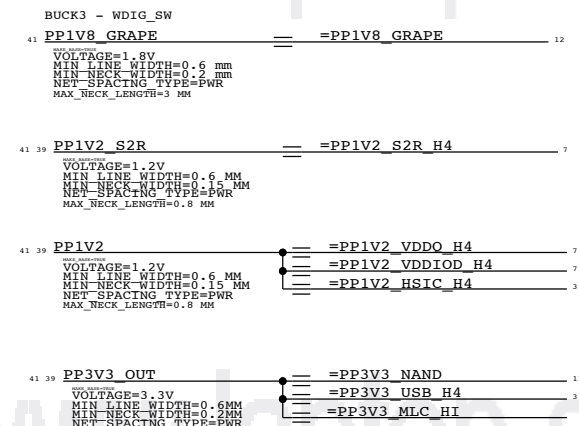
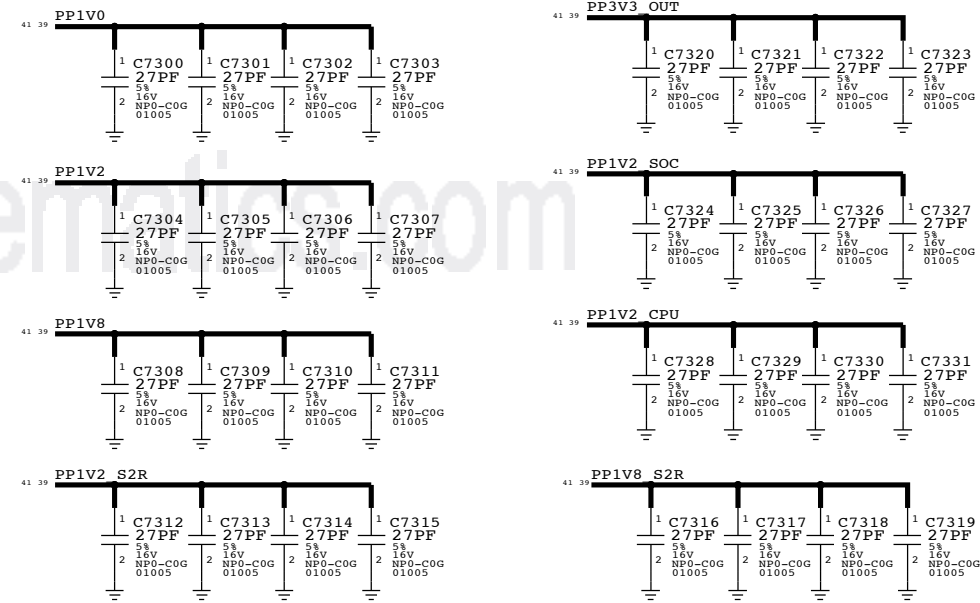

PAGE TITLE		SYNC DATE=N/A	
<b>Power: Aliases</b>			
Apple Inc.		DRAWING NUMBER	SIZE
Apple		051-9374	D
NOTICE OF PROPRIETARY PROPERTY:		REVISION	
THE INFORMATION CONTAINED HEREIN IS THE PROPRIETARY PROPERTY OF APPLE INC. THE POSSESSOR AGREES TO THE FOLLOWING:		13.0.0	
I TO MAINTAIN THIS DOCUMENT IN CONFIDENCE		PAGE	
II NOT TO REPRODUCE OR COPY IT		73 OF 102	
III NOT TO REVEAL OR PUBLISH IT IN WHOLE OR PART		SHEET	
IV ALL RIGHTS RESERVED		39 OF 46	

www.laptop-schematics.com

www.laptop-schematics.com

www.laptop-schematics.com

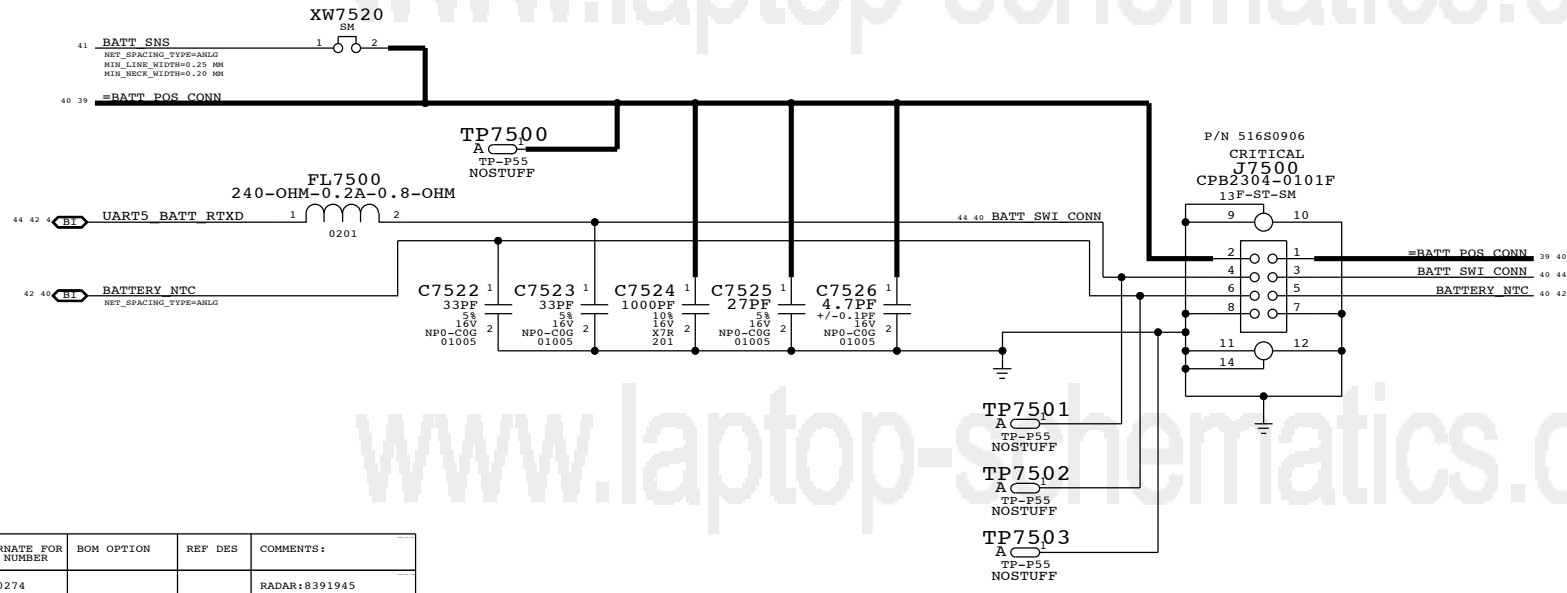

PART NUMBER	ALTERNATE FOR PART NUMBER	BOM OPTION	REF DES	COMMENTS:
15580644	15580274			RADAR:8391945

FL7500, L1700, L1701, L1702, L1800, L1920, L2600, L2601, L2602, L2700, L2701, L2702, L2800, L2900, L2901, L2902, L2903, L2960, L2961, L2962, L2963

SYNC MASTER=N/A		SYNC DATE=N/A	
<b>POWER: BATTERY CONNECTOR</b>			
Apple Inc.		DRAWING NUMBER	051-9374
		REVISION	13.0.0
NOTICE OF PROPRIETARY PROPERTY:		BRANCH	
THE INFORMATION CONTAINED HEREIN IS THE PROPRIETARY PROPERTY OF APPLE INC. THE POSSESSOR AGREES TO THE FOLLOWING:		PAGE	75 OF 102
I TO MAINTAIN THIS DOCUMENT IN CONFIDENCE		SHEET	40 OF 46
II NOT TO REPRODUCE OR COPY IT			
III NOT TO REVEAL OR PUBLISH IT IN WHOLE OR PART			
IV ALL RIGHTS RESERVED			

PART#	QTY	DESCRIPTION	REFERENCE DESIGNATOR(S)	CRITICAL	BOM OPTION
34380593	1	IC, PMU, ALISON, D1946A5, OTPXX, UFBGA292	U8100	CRITICAL	

PART NUMBER	ALTERNATE FOR PART NUMBER	BOM OPTION	REF DES	COMMENTS:
19780392	19780299		Y8138	ALT FOUNDRY

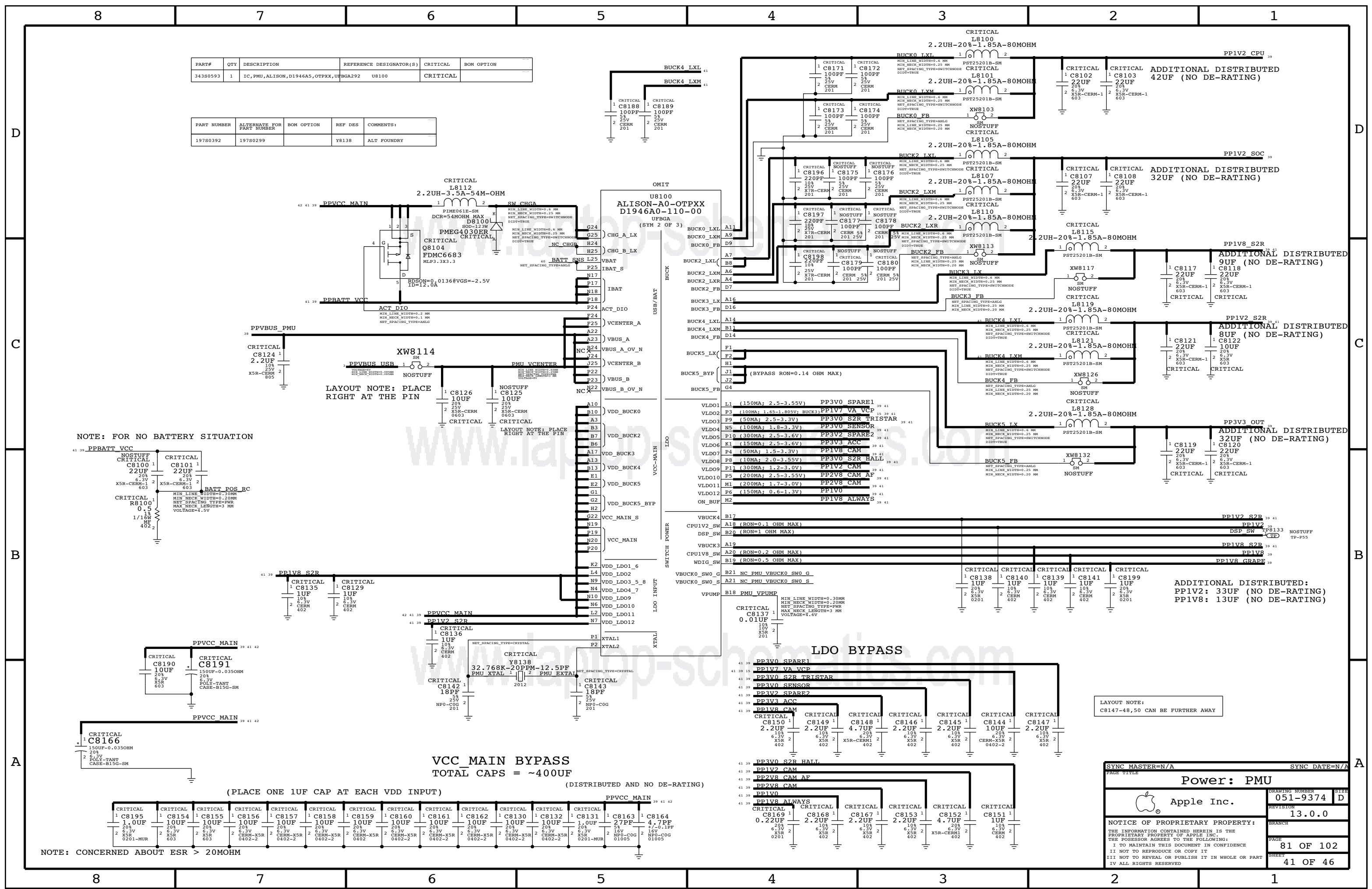

NOTE: FOR NO BATTERY SITUATION

LAYOUT NOTE: PLACE RIGHT AT THE PIN

LAYOUT NOTE: PLACE RIGHT AT THE PIN

LAYOUT NOTE: C8147-48,50 CAN BE FURTHER AWAY

VCC\_MAIN BYPASS  
TOTAL CAPS = ~400UF  
(DISTRIBUTED AND NO DE-RATING)

(PLACE ONE 1UF CAP AT EACH VDD INPUT)

CRITICAL	CRITICAL	CRITICAL	CRITICAL	CRITICAL	CRITICAL	CRITICAL	CRITICAL	CRITICAL	CRITICAL	CRITICAL	CRITICAL	CRITICAL	CRITICAL	CRITICAL	CRITICAL	CRITICAL	CRITICAL	CRITICAL	CRITICAL
1 C8195	1 C8154	1 C8155	1 C8156	1 C8157	1 C8158	1 C8159	1 C8160	1 C8161	1 C8162	1 C8130	1 C8132	1 C8131	1 C8163	1 C8164	1 C8196	1 C8197	1 C8198	1 C8199	1 C8100
2 6.3V X5R	2 6.3V X5R	2 6.3V X5R	2 6.3V X5R	2 6.3V X5R	2 6.3V X5R	2 6.3V X5R	2 6.3V X5R	2 6.3V X5R	2 6.3V X5R	2 6.3V X5R	2 6.3V X5R	2 6.3V X5R	2 6.3V X5R	2 6.3V X5R	2 6.3V X5R	2 6.3V X5R	2 6.3V X5R	2 6.3V X5R	2 6.3V X5R
0.01-MUR	0.01-MUR	0.01-MUR	0.01-MUR	0.01-MUR	0.01-MUR	0.01-MUR	0.01-MUR	0.01-MUR	0.01-MUR	0.01-MUR	0.01-MUR	0.01-MUR	0.01-MUR	0.01-MUR	0.01-MUR	0.01-MUR	0.01-MUR	0.01-MUR	0.01-MUR

NOTE: CONCERNED ABOUT ESR > 20MOHM

PAGE TITLE		SYNC DATE=N/A	
<b>Power: PMU</b>			
Apple Inc.		DRAWING NUMBER	SIZE
NOTICE OF PROPRIETARY PROPERTY:		051-9374	D
THE INFORMATION CONTAINED HEREIN IS THE PROPRIETARY PROPERTY OF APPLE INC. THE POSSESSOR AGREES TO THE FOLLOWING:		REVISION	
I TO MAINTAIN THIS DOCUMENT IN CONFIDENCE		13.0.0	
II NOT TO REPRODUCE OR COPY IT		BRANCH	
III NOT TO REVEAL OR PUBLISH IT IN WHOLE OR PART		PAGE	
IV ALL RIGHTS RESERVED		81 OF 102	
		SHEET	
		41 OF 46	

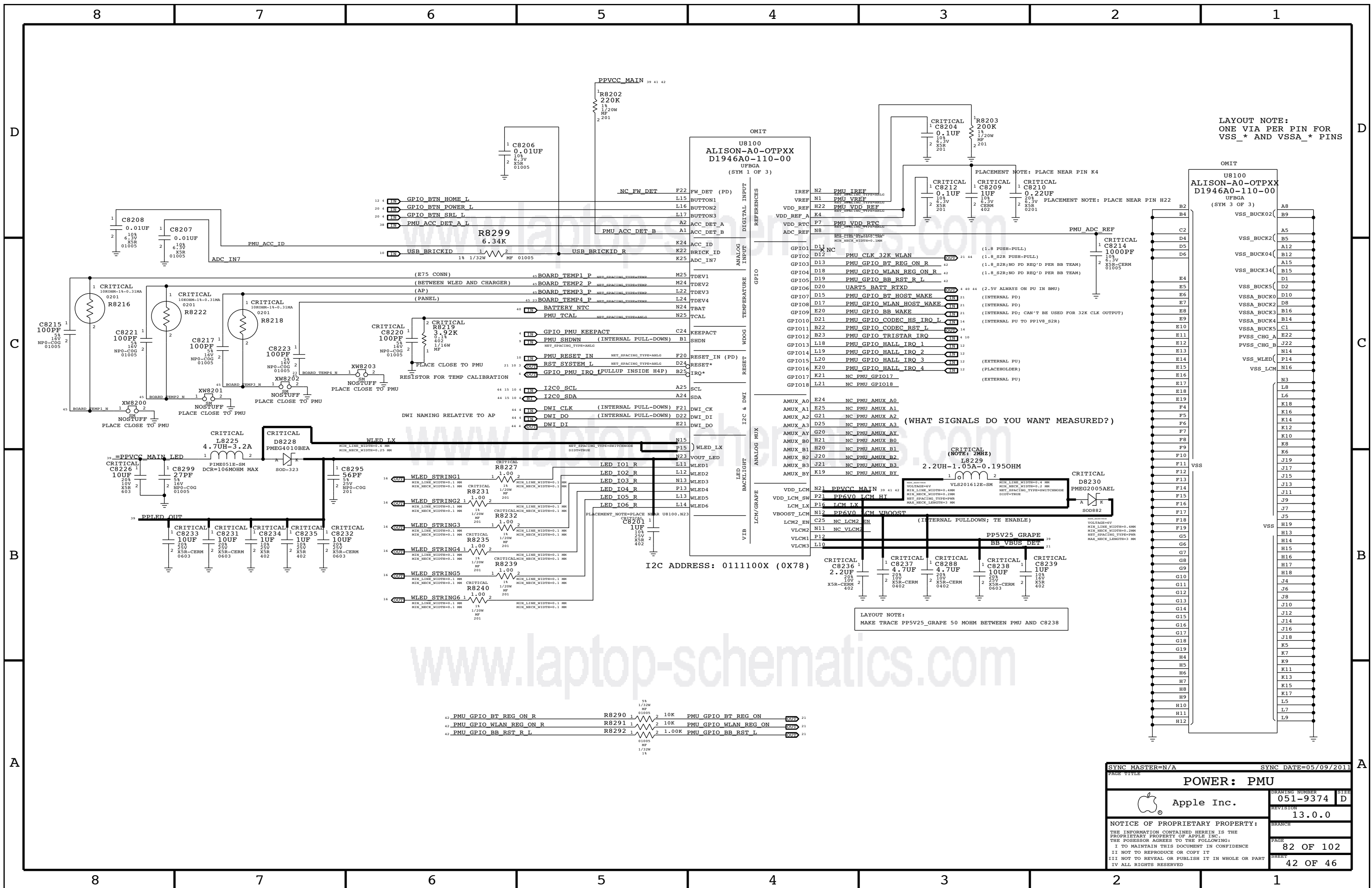

LAYOUT NOTE:  
ONE VIA PER PIN FOR  
VSS\_\* AND VSSA\_\* PINS

(WHAT SIGNALS DO YOU WANT MEASURED?)

LAYOUT NOTE:  
MAKE TRACE PPSV25\_GRAPE 50 MOHM BETWEEN PMU AND C8238

SYNC MASTER=N/A		SYNC DATE=05/09/2011	
<b>POWER: PMU</b>			
Apple Inc.		DRAWING NUMBER	SIZE
Apple logo		051-9374	D
NOTICE OF PROPRIETARY PROPERTY:		REVISION	
THE INFORMATION CONTAINED HEREIN IS THE PROPRIETARY PROPERTY OF APPLE INC. THE POSSESSOR AGREES TO THE FOLLOWING:		13.0.0	
I TO MAINTAIN THIS DOCUMENT IN CONFIDENCE		BRANCH	
II NOT TO REPRODUCE OR COPY IT		PAGE	82 OF 102
III NOT TO REVEAL OR PUBLISH IT IN WHOLE OR PART		SHEET	42 OF 46
IV ALL RIGHTS RESERVED			

# MECHANICAL PARTS

## PD PARTS

PART#	QTY	DESCRIPTION	REFERENCE DESIGNATOR(S)	BOM OPTION
806-4017	1	FENCE,MAIN,MLB,YY	FENCE_MLB	
806-3782	1	CAN,MAIN,MLB,WIFI,YY	CAN_WIFI	
806-3715	1	FENCE,RADIO,MLB,SWAPPED,YY	CAN_RADIO	CELL

## TOP BARCODE LABEL/EEE CODES (ONLY ONE IS USED PER BOM)

PART#	QTY	DESCRIPTION	REFERENCE DESIGNATOR(S)	CRITICAL	BOM OPTION
825-7639	1	EEEE FOR 639-3251 (X123 ENTRY)	DNVV	CRITICAL	EEEE_X123_ENTRY
825-7639	1	EEEE FOR 639-4129 (X123A ENTRY)	F78H	CRITICAL	EEEE_X123A_ENTRY
825-7639	1	EEEE FOR 639-4130 (X123B ENTRY)	F78J	CRITICAL	EEEE_X123B_ENTRY
825-7639	1	EEEE FOR 639-3923 (X123 GOOD)	F3JV	CRITICAL	EEEE_X123_BETTER
825-7639	1	EEEE FOR 639-3924 (X123 BETTER)	F3JQ	CRITICAL	EEEE_X123_BEST
825-7639	1	EEEE FOR 639-3415 (X123A GOOD)	DY62	CRITICAL	EEEE_X123A_GOOD
825-7639	1	EEEE FOR 639-3925 (X123A BETTER)	F3JN	CRITICAL	EEEE_X123A_BETTER
825-7639	1	EEEE FOR 639-3926 (X123A BEST)	F3JP	CRITICAL	EEEE_X123A_BEST
825-7639	1	EEEE FOR 639-3416 (X123B GOOD)	DY63	CRITICAL	EEEE_X123B_GOOD
825-7639	1	EEEE FOR 639-3927 (X123B BETTER)	F3JR	CRITICAL	EEEE_X123B_BETTER
825-7639	1	EEEE FOR 639-3928 (X123B BEST)	F3JT	CRITICAL	EEEE_X123B_BEST

## PLATED THROUGH HOLES

DRILL SIZE: 1.1MM X 0.4MM  
PLATING SIZE: 1.4MM X 0.7MM

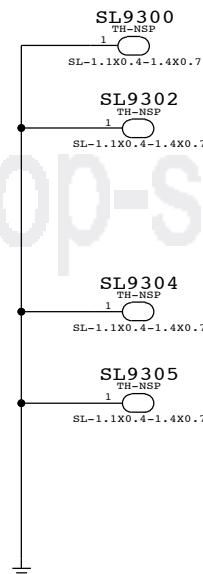

## STANDOFFS: P/N 860-1542

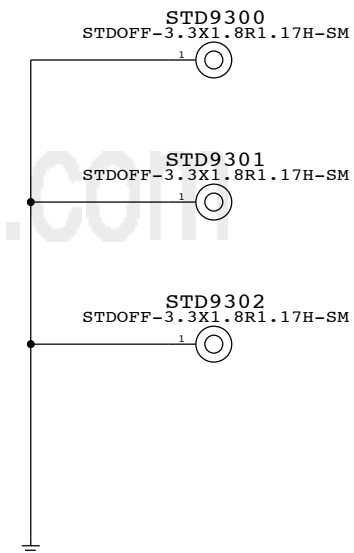

SYNC MASTER=N/A		SYNC DATE=N/A	
<b>MECHANICAL PARTS</b>			
 Apple Inc.		DRAWING NUMBER 051-9374	SIZE D
		REVISION 13.0.0	
NOTICE OF PROPRIETARY PROPERTY: THE INFORMATION CONTAINED HEREIN IS THE PROPRIETARY PROPERTY OF APPLE INC. THE POSSESSOR AGREES TO THE FOLLOWING: I TO MAINTAIN THIS DOCUMENT IN CONFIDENCE II NOT TO REPRODUCE OR COPY IT III NOT TO REVEAL OR PUBLISH IT IN WHOLE OR PART IV ALL RIGHTS RESERVED		BRANCH	PAGE 93 OF 102
			SHEET 43 OF 46

Clock Signal Constraints

NET_PHYSICAL_TYPE	AREA_TYPE	PHYSICAL_RULE_SET
CLK_50S	*	45_OHM_SE

NET_SPACING_TYPE1	NET_SPACING_TYPE2	AREA_TYPE	SPACING_RULE_SET
CLK	*	*	2:1_SPACING

ELECTRICAL_CONSTRAINT_SET	PHYSICAL	SPACING	NET_TYPE
R100	CLK_50S	CLK	AP_CLK_32K_CUMULUS 4 12
R101	CLK_50S	CLK	PMU_CLK_32K_WLAN 21 42
R102	CLK_50S	CLK	ISP0_CAM_REAR_CLK_R 4
R103	CLK_50S	CLK	ISP0_CAM_REAR_CLK 4 20
R104	CLK_50S	CLK	ISP1_CAM_FRONT_CLK_R 4 17
R105	CLK_50S	CLK	ISP1_CAM_FRONT_CLK 4 17
R106	CLK_50S	CLK	ISP1_CAM_FRONT_CLK_F 17
R107	CLK_50S	CLK	I2S0_CODEC_ASP_MCK 4 14
R108	CLK_50S	CLK	I2S0_CODEC_ASP_MCK_R 4
R109	CLK_50S	CLK	I2S1_SPKAMP_MCK 4 15
R110	CLK_50S	CLK	I2S1_SPKAMP_MCK_R 4

NAND

NET_PHYSICAL_TYPE	AREA_TYPE	PHYSICAL_RULE_SET
NAND_50S	*	45_OHM_SE

NET_SPACING_TYPE1	NET_SPACING_TYPE2	AREA_TYPE	SPACING_RULE_SET
NAND	*	*	2:1_SPACING

ELECTRICAL_CONSTRAINT_SET	PHYSICAL	SPACING	NET_TYPE
R111	NAND_50S	NAND	FMIO_AD<7..0> 5 11
R112	NAND_50S	NAND	FMIO_CE0_L 5 11
R113	NAND_50S	NAND	FMIO_CLE 5 11
R114	NAND_50S	NAND	FMIO_ALE 5 11
R115	NAND_50S	NAND	FMIO_RE_N 5 11
R116	NAND_50S	NAND	FMIO_WE_L 5 11
R117	NAND_50S	NAND	FMIO_DOS_P 5 11
R118	NAND_50S	NAND	FMI1_AD<7..0> 5 11
R119	NAND_50S	NAND	FMI1_CE0_L 5 11
R120	NAND_50S	NAND	FMI1_CLE 5 11
R121	NAND_50S	NAND	FMI1_ALE 5 11
R122	NAND_50S	NAND	FMI1_RE_N 5 11
R123	NAND_50S	NAND	FMI1_WE_L 5 11
R124	NAND_50S	NAND	FMI1_DOS_P 5 11

USB

NET_PHYSICAL_TYPE	AREA_TYPE	PHYSICAL_RULE_SET
USB_90D	*	90_OHM_DIFF

NET_SPACING_TYPE1	NET_SPACING_TYPE2	AREA_TYPE	SPACING_RULE_SET
USB	*	*	3:1_SPACING

ELECTRICAL_CONSTRAINT_SET	PHYSICAL	SPACING	NET_TYPE
R125	USB_90D	USR	SOC_USB_D_P 3 10
R126	USB_90D	USR	SOC_USB_D_N 3 10
R127	USB_90D	USR	USB_BB_D_P 10 21
R128	USB_90D	USR	USB_BB_D_N 10 21
R129	USB_90D	USR	TS_E75_DPAIR1_P 10 38
R130	USB_90D	USR	TS_E75_DPAIR1_N 10 38
R131	USB_90D	USR	TS_E75_DPAIR2_P 10 38
R132	USB_90D	USR	TS_E75_DPAIR2_N 10 38
R133	USB_90D	USR	CONN_DP1_P 38
R134	USB_90D	USR	CONN_DP1_N 38
R135	USB_90D	USR	CONN_DP2_P 38
R136	USB_90D	USR	CONN_DP2_N 38

HSIC

NET_PHYSICAL_TYPE	AREA_TYPE	PHYSICAL_RULE_SET
HSIC_50S	*	45_OHM_SE

NET_SPACING_TYPE1	NET_SPACING_TYPE2	AREA_TYPE	SPACING_RULE_SET
HSIC	*	*	3:1_SPACING

ELECTRICAL_CONSTRAINT_SET	PHYSICAL	SPACING	NET_TYPE
R137	HSIC_50S	HSIC	HSIC1_BB_STB 3 21
R138	HSIC_50S	HSIC	HSIC1_BB_DATA 3 21
R139	HSIC_50S	HSIC	HSIC2_WLAN_STB 3 21
R140	HSIC_50S	HSIC	HSIC2_WLAN_DATA 3 21

JTAG

NET_PHYSICAL_TYPE	AREA_TYPE	PHYSICAL_RULE_SET
JTAG_50S	*	45_OHM_SE

NET_SPACING_TYPE1	NET_SPACING_TYPE2	AREA_TYPE	SPACING_RULE_SET
JTAG	*	*	2:1_SPACING

ELECTRICAL_CONSTRAINT_SET	PHYSICAL	SPACING	NET_TYPE
R141	JTAG_50S	JTAG	JTAG_SOC_TCK 3 10
R142	JTAG_50S	JTAG	JTAG_SOC_TMS 3 10
R143	JTAG_50S	JTAG	JTAG_SOC_TDI 3
R144	JTAG_50S	JTAG	JTAG_SOC_TDO 3 9
R145	JTAG_50S	JTAG	JTAG_SOC_TRST_L 3 9
R146	JTAG_50S	JTAG	BB_JTAG_TCK 4 21 24
R147	JTAG_50S	JTAG	BB_JTAG_TMS 4 21 24
R148	JTAG_50S	JTAG	BB_JTAG_TDI 4 21 24
R149	JTAG_50S	JTAG	BB_JTAG_TDO 4 21 24
R150	JTAG_50S	JTAG	BB_JTAG_TRST_L 4 21 24

I2C

NET_PHYSICAL_TYPE	AREA_TYPE	PHYSICAL_RULE_SET
I2C_50S	*	45_OHM_SE

NET_SPACING_TYPE1	NET_SPACING_TYPE2	AREA_TYPE	SPACING_RULE_SET
I2C	*	*	2:1_SPACING

ELECTRICAL_CONSTRAINT_SET	PHYSICAL	SPACING	NET_TYPE
R151	I2C_50S	I2C	I2C0_SDA 4 10 15 42
R152	I2C_50S	I2C	I2C0_SCL 4 10 15 42
R153	I2C_50S	I2C	I2C1_SDA 4 18 19
R154	I2C_50S	I2C	I2C1_SCL 4 18 19
R155	I2C_50S	I2C	I2C2_SDA 4 17 18
R156	I2C_50S	I2C	I2C2_SCL 4 17 18
R157	I2C_50S	I2C	I2C2_SDA_F 17
R158	I2C_50S	I2C	I2C2_SCL_F 17
R159	I2C_50S	I2C	ISP0_CAM_REAR_SCL 6 20
R160	I2C_50S	I2C	ISP0_CAM_REAR_SDA 6 20
R161	I2C_50S	I2C	ISP1_CAM_FRONT_SCL 6 17
R162	I2C_50S	I2C	ISP1_CAM_FRONT_SDA 6 17
R163	I2C_50S	I2C	ISP1_CAM_FRONT_SCL_F 17
R164	I2C_50S	I2C	ISP1_CAM_FRONT_SDA_F 17
R165	I2C_50S	I2C	MLC_SDA_3V3
R166	I2C_50S	I2C	MLC_SCL_3V3
R167	I2C_50S	I2C	LVDS_DDC_DATA
R168	I2C_50S	I2C	LVDS_DDC_CLK

VREF

NET_PHYSICAL_TYPE	AREA_TYPE	PHYSICAL_RULE_SET
VREF	*	45_OHM_SE

NET_SPACING_TYPE1	NET_SPACING_TYPE2	AREA_TYPE	SPACING_RULE_SET
VREF	*	*	2:1_SPACING

ELECTRICAL_CONSTRAINT_SET	PHYSICAL	SPACING	NET_TYPE
R169	VREF	VREF	PPVREF_DDR0_CA 7
R170	VREF	VREF	PPVREF_DDR0_DO 7
R171	VREF	VREF	PPVREF_DDR1_CA 7
R172	VREF	VREF	PPVREF_DDR1_DO 7

DWI

NET_PHYSICAL_TYPE	AREA_TYPE	PHYSICAL_RULE_SET
DWI_45S	*	45_OHM_SE

NET_SPACING_TYPE1	NET_SPACING_TYPE2	AREA_TYPE	SPACING_RULE_SET
DWI	*	*	2:1_SPACING

ELECTRICAL_CONSTRAINT_SET	PHYSICAL	SPACING	NET_TYPE
R173	DWI_45S	DWI	DWI_CLK 4 42
R174	DWI_45S	DWI	DWI_DI 4 42
R175	DWI_45S	DWI	DWI_DO 4 42

I2S

NET_PHYSICAL_TYPE	AREA_TYPE	PHYSICAL_RULE_SET
I2S_45S	*	45_OHM_SE

NET_SPACING_TYPE1	NET_SPACING_TYPE2	AREA_TYPE	SPACING_RULE_SET
I2S	*	*	3:1_SPACING
I2S	I2S	*	2:1_SPACING

ELECTRICAL_CONSTRAINT_SET	PHYSICAL	SPACING	NET_TYPE
R176	I2S_45S	I2S	I2S0_CODEC_ASP_BCLK 4 14
R177	I2S_45S	I2S	I2S0_CODEC_ASP_LRCK 4 14
R178	I2S_45S	I2S	I2S0_CODEC_ASP_DOUT 4 14
R179	I2S_45S	I2S	I2S0_CODEC_ASP_DIN 4 14
R180	I2S_45S	I2S	I2S0_CODEC_ASP_SDOUT 14
R181	I2S_45S	I2S	I2S1_SPKAMP_BCLK 4 15
R182	I2S_45S	I2S	I2S1_SPKAMP_LRCK 4 15
R183	I2S_45S	I2S	I2S1_SPKAMP_DOUT 4 15
R184	I2S_45S	I2S	I2S1_SPKAMP_DIN 4 15
R185	I2S_45S	I2S	I2S2_CODEC_XSP_BCLK 4 14
R186	I2S_45S	I2S	I2S2_CODEC_XSP_LRCK 4 14
R187	I2S_45S	I2S	I2S2_CODEC_XSP_DOUT 4 14
R188	I2S_45S	I2S	I2S2_CODEC_XSP_DIN 4 14
R189	I2S_45S	I2S	I2S2_CODEC_XSP_SDOUT 14
R190	I2S_45S	I2S	I2S3_BT_BCLK 4 21
R191	I2S_45S	I2S	I2S3_BT_LRCK 4 21
R192	I2S_45S	I2S	I2S3_BT_DOUT 4 21
R193	I2S_45S	I2S	I2S3_BT_DIN 4 21

UART

NET_PHYSICAL_TYPE	AREA_TYPE	PHYSICAL_RULE_SET
UART_45S	*	45_OHM_SE

NET_SPACING_TYPE1	NET_SPACING_TYPE2	AREA_TYPE	SPACING_RULE_SET
UART	*	*	2:1_SPACING

ELECTRICAL_CONSTRAINT_SET	PHYSICAL	SPACING	NET_TYPE
R194	UART_45S	UART	UART0_DEBUG_RXD 4 10
R195	UART_45S	UART	UART0_DEBUG_TXD 4 10
R196	UART_45S	UART	UART1_BT_RXD 4 21
R197	UART_45S	UART	UART1_BT_TXD 4 21
R198	UART_45S	UART	UART1_BT_RTS_L 4 21
R199	UART_45S	UART	UART1_BT_CTS_L 4 21
R200	UART_45S	UART	UART2_ACC_RXD 4 10
R201	UART_45S	UART	UART2_ACC_TXD 4 10
R202	UART_45S	UART	UART3_WLAN_RXD 4 21
R203	UART_45S	UART	UART3_WLAN_TXD 4 21
R204	UART_45S	UART	UART4_BB_RXD 4 10 21
R205	UART_45S	UART	UART4_BB_TXD 4 10 21
R206	UART_45S	UART	UART4_BB_RTS_L 4 21
R207	UART_45S	UART	UART4_BB_CTS_L 4 21
R208	UART_45S	UART	UART5_BATT_RTXD 4 40 42
R209	UART_45S	UART	BATT_SWI_CONN 40

SPI

NET_PHYSICAL_TYPE	AREA_TYPE	PHYSICAL_RULE_SET
SPI_45S	*	45_OHM_SE

NET_SPACING_TYPE1	NET_SPACING_TYPE2	AREA_TYPE	SPACING_RULE_SET
SPI	*	*	2:1_SPACING

ELECTRICAL_CONSTRAINT_SET	PHYSICAL	SPACING	NET_TYPE
R210	SPI_45S	SPT	SPI1_GRAPE_MISO 4 12
R211	SPI_45S	SPT	SPI1_GRAPE_MOSI 4 12
R212	SPI_45S	SPT	SPI1_GRAPE_SCLK 4 12
R213	SPI_45S	SPT	SPI1_GRAPE_SCLK_R 12
R214	SPI_45S	SPT	SPI1_GRAPE_CS_L 4 12
R215	SPI_45S	SPT	SPI2_CODEC_MISO 4 14
R216	SPI_45S	SPT	SPI2_CODEC_MOSI 4 14
R217	SPI_45S	SPT	SPI2_CODEC_SCLK 4 14
R218	SPI_45S	SPT	SPI2_CODEC_CS_L 4 14

PAGE TITLE		SYNC MASTER=N/A		SYNC DATE=N/A	
<b>CONSTRAINTS: ASSIGNMENTS</b>					
 Apple Inc.		DRAWING NUMBER	051-9374	SIZE	D
		REVISION	13.0.0	BRANCH	
NOTICE OF PROPRIETARY PROPERTY: THE INFORMATION CONTAINED HEREIN IS THE PROPRIETARY PROPERTY OF APPLE INC. THE POSSESSOR AGREES TO THE FOLLOWING: I TO MAINTAIN THIS DOCUMENT IN CONFIDENCE II NOT TO REPRODUCE OR COPY IT III NOT TO REVEAL OR PUBLISH IT IN WHOLE OR PART IV ALL RIGHTS RESERVED		PAGE	100 OF 102	SHEET	44 OF 46

MIPI

NET_PHYSICAL_TYPE	AREA_TYPE	PHYSICAL_RULE_SET
MIPI_90D	*	90_OHM_DIFF

NET_SPACING_TYPE1	NET_SPACING_TYPE2	AREA_TYPE	SPACING_RULE_SET
MIPI	*	*	3:1_SPACING

ELECTRICAL_CONSTRAINT_SET	NET_TYPE		SPACING	NET_NAME	Value
	PHYSICAL	SPACING			
E191	MIPI_90D	MIPI		MIPIOD_DATA_P<0>	6 16
E192	MIPI_90D	MIPI		MIPIOD_DATA_N<0>	6 16
E193	MIPI_90D	MIPI		MIPIOD_DATA_P<1>	6 16
E194	MIPI_90D	MIPI		MIPIOD_DATA_N<1>	6 16
E195	MIPI_90D	MIPI		MIPIOD_DATA_P<2>	6 16
E196	MIPI_90D	MIPI		MIPIOD_DATA_N<2>	6 16
E197	MIPI_90D	MIPI		MIPIOD_DATA_P<3>	6 16
E198	MIPI_90D	MIPI		MIPIOD_DATA_N<3>	6 16
E199	MIPI_90D	MIPI		MIPIOD_CLK_P	6 16
E200	MIPI_90D	MIPI		MIPIOD_CLK_N	6 16
E201	MIPI_90D	MIPI		MIPIOC_CAM_REAR_DATA_P<0>	6 20
E202	MIPI_90D	MIPI		MIPIOC_CAM_REAR_DATA_N<0>	6 20
E203	MIPI_90D	MIPI		MIPIOC_CAM_REAR_DATA_P<1>	6 20
E204	MIPI_90D	MIPI		MIPIOC_CAM_REAR_DATA_N<1>	6 20
E205	MIPI_90D	MIPI		MIPIOC_CAM_REAR_CLK_P	6 20
E206	MIPI_90D	MIPI		MIPIOC_CAM_REAR_CLK_N	6 20
E207	MIPI_90D	MIPI		MIPIOC_CAM_REAR_DATA_FILT_P<0>	20
E208	MIPI_90D	MIPI		MIPIOC_CAM_REAR_DATA_FILT_N<0>	20
E209	MIPI_90D	MIPI		MIPIOC_CAM_REAR_DATA_FILT_P<1>	20
E210	MIPI_90D	MIPI		MIPIOC_CAM_REAR_DATA_FILT_N<1>	20
E211	MIPI_90D	MIPI		MIPIOC_CAM_REAR_CLK_FILT_P	20
E212	MIPI_90D	MIPI		MIPIOC_CAM_REAR_CLK_FILT_N	20
E213	MIPI_90D	MIPI		MIPI1C_CAM_FRONT_DATA_P<0>	6 17
E214	MIPI_90D	MIPI		MIPI1C_CAM_FRONT_DATA_N<0>	6 17
E215	MIPI_90D	MIPI		MIPI1C_CAM_FRONT_CLK_P	6 17
E216	MIPI_90D	MIPI		MIPI1C_CAM_FRONT_CLK_N	6 17
E217	MIPI_90D	MIPI		MIPI1C_CAM_FRONT_DATA_FILT_P<0>	17
E218	MIPI_90D	MIPI		MIPI1C_CAM_FRONT_DATA_FILT_N<0>	17
E219	MIPI_90D	MIPI		MIPI1C_CAM_FRONT_CLK_FILT_P	17
E220	MIPI_90D	MIPI		MIPI1C_CAM_FRONT_CLK_FILT_N	17

DMIC

NET_PHYSICAL_TYPE	AREA_TYPE	PHYSICAL_RULE_SET
DMIC_45S	*	45_OHM_SE

NET_SPACING_TYPE1	NET_SPACING_TYPE2	AREA_TYPE	SPACING_RULE_SET
DMIC	*	*	2:1_SPACING

ELECTRICAL_CONSTRAINT_SET	NET_TYPE		SPACING	NET_NAME	Value
	PHYSICAL	SPACING			
E193	DMIC_45S	DMIC		L81_DMIC1_FF_SCLK	14
E194	DMIC_45S	DMIC		L81_DMIC1_FF_SD	14
E195	DMIC_45S	DMIC		DMIC1_FF_SCLK	13 14
E196	DMIC_45S	DMIC		DMIC1_FF_SD	13 14
E197	DMIC_45S	DMIC		DMIC1_FF_SCLK_CONN	13

AUDIO

NET_SPACING_TYPE1	NET_SPACING_TYPE2	AREA_TYPE	SPACING_RULE_SET
AUDIO	*	*	3:1_SPACING

ELECTRICAL_CONSTRAINT_SET	NET_TYPE		SPACING	NET_NAME	Value
	PHYSICAL	SPACING			
E221	USB_90D	USB		MIKEY_TS_P	10 14
E222	USB_90D	USB		MIKEY_TS_N	10 14
E223	USB_90D	USB		L81_MBUS_P	14
E224	USB_90D	USB		L81_MBUS_N	14
E225	SPEAKER	AUDIO		SPKR_L_CONN_P	15 38
E226	SPEAKER	AUDIO		SPKR_L_CONN_N	15 38
E227	SPEAKER	AUDIO		SPKR_R_CONN_P	15 38
E228	SPEAKER	AUDIO		SPKR_R_CONN_N	15 38
E229	AUDIO_DIFF	AUDIO		HP_MIC_P	14
E230	AUDIO_DIFF	AUDIO		HP_MIC_N	14
E231	AUDIO_DIFF	AUDIO		L81_AIN2_P	14
E232	AUDIO_DIFF	AUDIO		L81_AIN2_N	14

LVDS

NET_PHYSICAL_TYPE	AREA_TYPE	PHYSICAL_RULE_SET
LVDS_90D	*	90_OHM_DIFF

NET_SPACING_TYPE1	NET_SPACING_TYPE2	AREA_TYPE	SPACING_RULE_SET
LVDS	*	*	3:1_SPACING

ELECTRICAL_CONSTRAINT_SET	NET_TYPE		SPACING	NET_NAME	Value
	PHYSICAL	SPACING			
E233	LVDS_90D	LVDS		MIPI_DATA_CONN_P<3..0>	16
E234	LVDS_90D	LVDS		MIPI_DATA_CONN_N<3..0>	16
E235	LVDS_90D	LVDS		MIPI_CLK_CONN_P	16
E236	LVDS_90D	LVDS		MIPI_CLK_CONN_N	16

TEMP SENSORS

NET_PHYSICAL_TYPE	AREA_TYPE	PHYSICAL_RULE_SET
TEMP	*	TEMP_SENSE

NET_SPACING_TYPE1	NET_SPACING_TYPE2	AREA_TYPE	SPACING_RULE_SET
TEMP	*	*	3:1_SPACING

ELECTRICAL_CONSTRAINT_SET	NET_TYPE		SPACING	NET_NAME	Value
	PHYSICAL	SPACING			
E237	TEMP	TEMP		BOARD_TEMP1_P	42
E238	TEMP	TEMP		BOARD_TEMP1_N	42
E239	TEMP	TEMP		BOARD_TEMP2_P	42
E240	TEMP	TEMP		BOARD_TEMP2_N	42
E241	TEMP	TEMP		BOARD_TEMP3_P	42
E242	TEMP	TEMP		BOARD_TEMP3_N	42
E243	TEMP	TEMP		BOARD_TEMP4_P	23 42
E244	TEMP	TEMP		BOARD_TEMP4_N	23 42

XTAL

NET_SPACING_TYPE1	NET_SPACING_TYPE2	AREA_TYPE	SPACING_RULE_SET
CRYSTAL	*	*	5:1_SPACING

ELECTRICAL_CONSTRAINT_SET	NET_TYPE		SPACING	NET_NAME	Value
	PHYSICAL	SPACING			
E245	CRYSTAL	CRYSTAL		XTAL_SOC_24M_I	3
E246	CRYSTAL	CRYSTAL		XTAL_SOC_24M_O	3
E247	CRYSTAL	CRYSTAL		XTAL_SOC_24M_O_R	3

SYNC MASTER=N/A SYNC DATE=N/A

**CONSTRAINTS: ASSIGNMENTS**

Apple Inc.

DRAWING NUMBER: 051-9374 SIZE: D

REVISION: 13.0.0

NOTICE OF PROPRIETARY PROPERTY: THE INFORMATION CONTAINED HEREIN IS THE PROPRIETARY PROPERTY OF APPLE INC. THE POSSESSOR AGREES TO THE FOLLOWING: I TO MAINTAIN THIS DOCUMENT IN CONFIDENCE II NOT TO REPRODUCE OR COPY IT III NOT TO REVEAL OR PUBLISH IT IN WHOLE OR PART IV ALL RIGHTS RESERVED

PAGE: 101 OF 102 SHEET: 45 OF 46

# MLB CONSTRAINTS

BOARD LAYERS	BOARD AREAS	BOARD UNITS (MIL OR MM)	ALLEGRO VERSION
TOP, ISL2, ISL3, ISL4, ISL5, ISL6, ISL7, ISL8, ISL9, BOTTOM	NO_TYPE, BGA	MM	16.2

## PHYSICAL CONSTRAINTS

PHYSICAL_RULE_SET	LAYER	ALLOW ROUTE ON LAYER?	MINIMUM LINE WIDTH	MINIMUM NECK WIDTH	MAXIMUM NECK LENGTH	DIFFPAIR PRIMARY GAP	DIFFPAIR NECK GAP
DEFAULT	*	Y	=45_OHM_SE	=45_OHM_SE	30 MM	0 MM	0 MM
STANDARD	*	Y	=DEFAULT	=DEFAULT	12.7 MM	=DEFAULT	=DEFAULT

## SINGLE-ENDED PHYSICAL RULES 45 OHMS

PHYSICAL_RULE_SET	LAYER	ALLOW ROUTE ON LAYER?	MINIMUM LINE WIDTH	MINIMUM NECK WIDTH	MAXIMUM NECK LENGTH	DIFFPAIR PRIMARY GAP	DIFFPAIR NECK GAP
45_OHM_SE	ISL2, ISL9	Y	0.053 MM	0.053 MM	3.0 MM		
45_OHM_SE	ISL4, ISL6	Y	0.055 MM	0.055 MM	3.0 MM		
45_OHM_SE	*	N	0.055 MM	0.055 MM	3.0 MM		

## 50 OHMS - CLEAR ON LAYER 2 AND 9

PHYSICAL_RULE_SET	LAYER	ALLOW ROUTE ON LAYER?	MINIMUM LINE WIDTH	MINIMUM NECK WIDTH	MAXIMUM NECK LENGTH	DIFFPAIR PRIMARY GAP	DIFFPAIR NECK GAP
50_OHM_SE	TOP, BOTTOM	Y	0.085 MM	0.085 MM	3.0 MM		
50_OHM_SE	*	N	0.085 MM	0.085 MM	3.0 MM		

## DIFFERENTIAL PAIR PHYSICAL RULES 90 OHMS

PHYSICAL_RULE_SET	LAYER	ALLOW ROUTE ON LAYER?	MINIMUM LINE WIDTH	MINIMUM NECK WIDTH	MAXIMUM NECK LENGTH	DIFFPAIR PRIMARY GAP	DIFFPAIR NECK GAP
90_OHM_DIFF	TOP	Y	0.089 MM	0.089 MM		0.150 MM	0.150 MM
90_OHM_DIFF	ISL2, ISL9	Y	0.051 MM	0.051 MM	=STANDARD	0.120 MM	0.120 MM
90_OHM_DIFF	ISL4, ISL6	Y	0.052 MM	0.052 MM	=STANDARD	0.120 MM	0.120 MM
90_OHM_DIFF	*	N	0.089 MM	0.089 MM	=STANDARD	0.150 MM	0.150 MM

## SPACING CONSTRAINTS

### DEFAULT/BGA SPACING RULES

SPACING_RULE_SET	LAYER	LINE-TO-LINE SPACING	WEIGHT
DEFAULT	*	0.08 MM	?
STANDARD	*	=DEFAULT	?
BGA_SPA	*	0.055 MM	?

NET_SPACING_TYPE1	NET_SPACING_TYPE2	AREA_TYPE	SPACING_RULE_SET
*	*	BGA	BGA_SPA
CLK	*	BGA	BGA_SPA
PWR	*	*	PWR_P1SPACING
GND	*	*	GND_P1SPACING
SWITCHNODE	*	*	SWITCHNODE
ANLG	*	*	3:1_SPACING

### REGULAR SPACING RULES

SPACING_RULE_SET	LAYER	LINE-TO-LINE SPACING	WEIGHT
1:1_SPACING	*	0.055 MM	?
0P08_SPACING	*	0.080 MM	?
1.5:1_SPACING	*	0.0825 MM	?
2:1_SPACING	*	0.11 MM	?
2.5:1_SPACING	*	0.137 MM	?
3:1_SPACING	*	0.165 MM	?
4:1_SPACING	*	0.22 MM	?
5:1_SPACING	*	0.275 MM	?
0P5MM_SPACING	*	0.5 MM	?
0P64MM_SPACING	*	0.64 MM	?

\*NOTE: ASSUMING 0.060MM DIELECTRIC THICKNESS

### POWER/GND SPACING RULES

SPACING_RULE_SET	LAYER	LINE-TO-LINE SPACING	WEIGHT
PWR_P1SPACING	*	0.1 MM	
GND_P1SPACING	*	0.1 MM	
SWITCHNODE	*	0.2 MM	

### NOTES:

- 0.075 MM ~ 3 MIL
- 0.089 MM ~ 3.5 MIL
- 0.102 MM ~ 4 MIL
- 0.114 MM ~ 4.5 MIL
- 0.125 MM ~ 5 MIL
- 0.140 MM ~ 5.5 MIL
- 0.15 MM ~ 6 MIL
- 0.18 MM ~ 7 MIL
- 0.2 MM ~ 8 MIL
- 0.25 MM ~ 10 MIL
- 0.3 MM ~ 12 MIL
- 0.33 MM ~ 13 MIL
- 0.4 MM ~ 16 MIL
- 1.0 MM = 39.37 MIL

## AUDIO/MISC PHYSICAL RULES

PHYSICAL_RULE_SET	LAYER	ALLOW ROUTE ON LAYER?	MINIMUM LINE WIDTH	MINIMUM NECK WIDTH	MAXIMUM NECK LENGTH	DIFFPAIR PRIMARY GAP	DIFFPAIR NECK GAP
1:1_DIFFPAIR	*	Y	=STANDARD	=STANDARD	=STANDARD	0.08 MM	0.08 MM
SPEAKER	*	Y	0.5 MM	0.20MM	10 MM	0.10 MM	0.10 MM
AUDIO_DIFF	*	Y	0.1 MM	0.10MM	10 MM	0.10 MM	0.10 MM
TEMP_SENSE	*	Y	0.1 MM	0.10MM	10 MM	0.08 MM	0.08 MM

## BGA AREA PHYSICAL RULES

NET_PHYSICAL_TYPE	AREA_TYPE	PHYSICAL_RULE_SET
*	BGA	BGA_PHY

PHYSICAL_RULE_SET	LAYER	ALLOW ROUTE ON LAYER?	MINIMUM LINE WIDTH	MINIMUM NECK WIDTH	MAXIMUM NECK LENGTH	DIFFPAIR PRIMARY GAP	DIFFPAIR NECK GAP
BGA_PHY	*	Y	0.055 MM	0.055 MM	=STANDARD	0.076 MM	0.075 MM

SYNC MASTER=N/A		SYNC DATE=N/A	
<b>CONSTRAINTS: MLB RULES</b>			
		DRAWING NUMBER 051-9374	SIZE D
		REVISION 13.0.0	BRANCH
NOTICE OF PROPRIETARY PROPERTY: THE INFORMATION CONTAINED HEREIN IS THE PROPRIETARY PROPERTY OF APPLE INC. THE POSSESSOR AGREES TO THE FOLLOWING: I TO MAINTAIN THIS DOCUMENT IN CONFIDENCE II NOT TO REPRODUCE OR COPY IT III NOT TO REVEAL OR PUBLISH IT IN WHOLE OR PART IV ALL RIGHTS RESERVED		PAGE 102 OF 102	SHEET 46 OF 46