

1. ALL RESISTANCE VALUES ARE IN OHMS, 0.1 WATT +/- 5%.
 2. ALL CAPACITANCE VALUES ARE IN MICROFARADS.
 3. ALL CRYSTALS & OSCILLATOR VALUES ARE IN HERTZ.

K94 CHOPIN MLB

REV	ECN	DESCRIPTION OF REVISION	CK APPD	DATE
A	0001052699	PRODUCTION RELEASED		2011-01-10

PVT
REV. A

LAST_MODIFIED=Mon Jan 10 13:11:06 2011

PDF	CSA	CONTENTS	SYNC	MASTER	DATE	PDF	CSA	CONTENTS	SYNC	MASTER	DATE
1	1	TABLE OF CONTENTS		MIKE	N/A	32	73	POWER: ALIASES		YOSH	N/A
2	2	BLOCK DIAGRAM: SYSTEM		MIKE	N/A	33	75	POWER: BATTERY CONNECTOR		YOSH	N/A
3	5	BOM TABLE		MIKE	N/A	34	81	POWER: PMU		YOSH	N/A
4	6	AP: MAIN		JAMES	N/A	35	82	POWER: PMU		YOSH	N/A
5	7	AP: I/Os		JAMES	N/A	36	83	POWER: 3.3V VR		YOSH	N/A
6	8	AP: NAND		JAMES	N/A	37	90	DEBUG AND MISC		MIKE	N/A
7	9	AP: TV,DP,MIPI		JAMES	N/A	38	93	FCT/ICT TEST/BRACKETS		MIKE	N/A
8	10	AP: PWR		JAMES	N/A	39	100	CONSTRAINTS: ASSIGNMENTS		MIKE	N/A
9	11	AP: PWR		JAMES	N/A	40	101	CONSTRAINTS: ASSIGNMENTS		MIKE	N/A
10	12	AP: MISC & ALIASES		JAMES	N/A	41	102	CONSTRAINTS: MLB RULES		MIKE	N/A
11	13	AP: VIDEO BUFFER,BB USB MUXES		JAMES	N/A	42	106	CONSTRAINTS: RF RULES		MIKE	N/A
12	14	NAND		JONATHAN	N/A						
13	17	VIDEO: DISPLAY PORT		JAMES	N/A						
14	20	VIDEO: MLC		MIKE	N/A						
15	21	VIDEO: MLC ALIASES		MIKE	N/A						
16	22	VIDEO: LVDS CONNECTOR		ALEX	N/A						
17	30	GRAPE: GROUNDHOG,CONN,BOOST		RAMSIN	N/A						
18	31	GRAPE: Z1, Z2		RAMSIN	N/A						
19	36	AUDIO: L63 CODEC		LENG	N/A						
20	37	AUDIO: SPEAKER AMP		LENG	N/A						
21	38	AUDIO: HEADPHONE OUT		LENG	N/A						
22	39	AUDIO: BLANK		LENG	N/A						
23	42	AUDIO: DETECT/MIC BIAS		LENG	N/A						
24	43	AUDIO: HP/MIC FILTERS		LENG	N/A						
25	54	CONNECTOR: CANADA FLEX CONN,SENSOR PANEL ALIASES		MARK B.	N/A						
26	55	CONNECTOR: CANADA FLEX FILTERS		MARK B.	N/A						
27	56	CONNECTOR: SENSOR PANEL CONNECTOR		MARK B.	N/A						
28	57	IO FLEX: DOCK COMPONENTS		JAMES	N/A						
29	59	IO FELX: B2B Connector		JAMES	N/A						
30	60	CONNECTOR: X23 WIFI/BT		MIKE	N/A						
31	61	CONNECTOR: X24 CELLULAR/GPS		MIKE	N/A						

www.laptop-schematics.com

DRAWING TITLE		CHOPIN MLB	
DRAWING NUMBER	051-8962	SIZE	D
	REVISION		A.0.0
NOTICE OF PROPRIETARY PROPERTY:		BRANCH	
THE INFORMATION CONTAINED HEREIN IS THE PROPRIETARY PROPERTY OF APPLE COMPUTER, INC. THE POSSESSOR AGREES TO THE FOLLOWING:		PAGE	
I TO MAINTAIN THIS DOCUMENT IN CONFIDENCE		1 OF 106	
II NOT TO REPRODUCE OR COPY IT		SHEET	
III NOT TO REVEAL OR PUBLISH IT IN WHOLE OR PART		1 OF 42	
IV ALL RIGHTS RESERVED			

DRAWING
TITLE=BACH
ABBREV=DRAWING

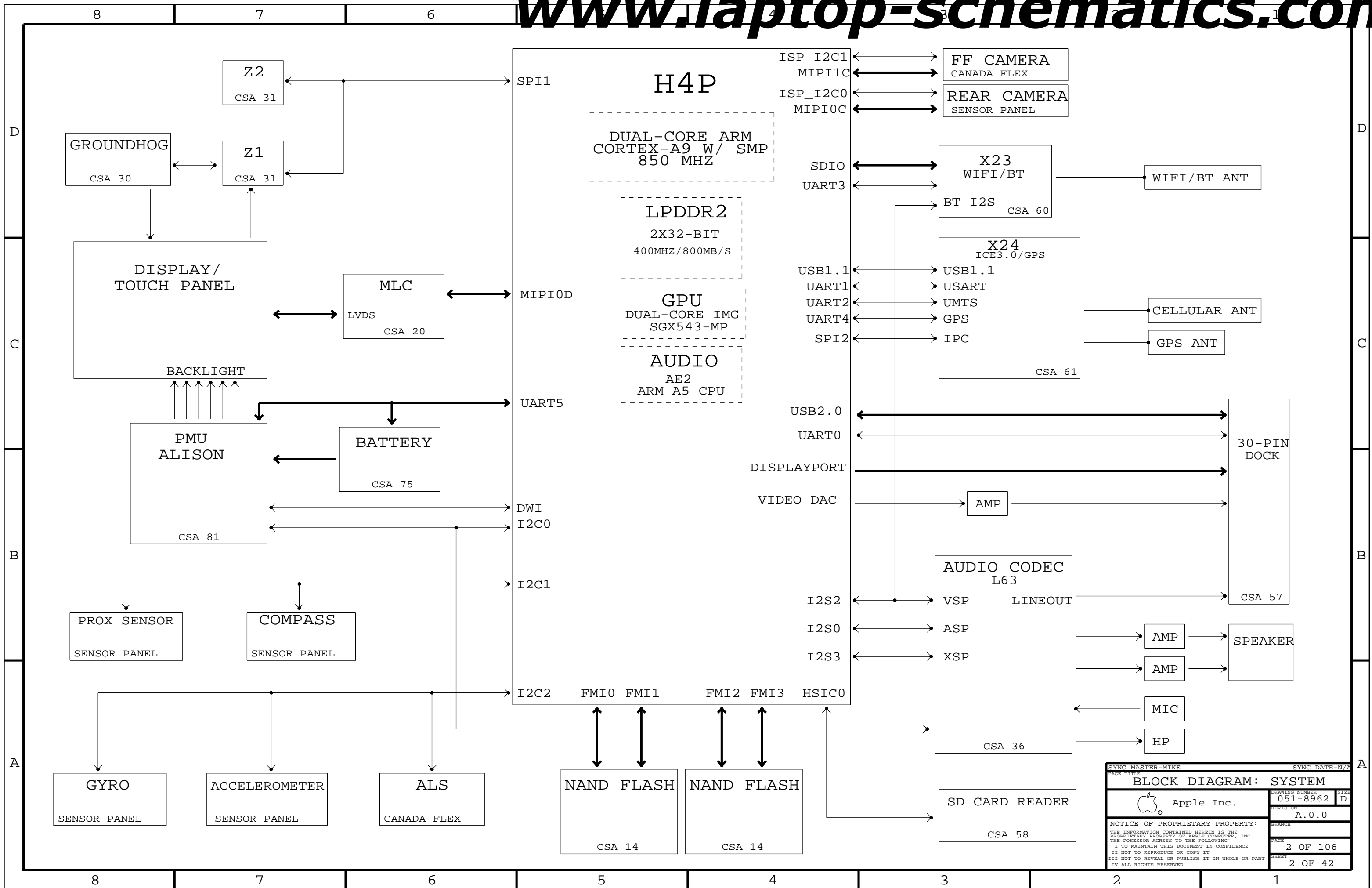

SYNC MASTER=MIKE		SYNC DATE=N/A	
BLOCK DIAGRAM: SYSTEM			
Apple Inc.	DRAWING NUMBER	051-8962	SIZE
	REVISION	A.0.0	
NOTICE OF PROPRIETARY PROPERTY:		BRANCH	
THE INFORMATION CONTAINED HEREIN IS THE PROPRIETARY PROPERTY OF APPLE COMPUTER, INC. THE POSSESSOR AGREES TO THE FOLLOWING:		PAGE	
I TO MAINTAIN THIS DOCUMENT IN CONFIDENCE		2 OF 106	
II NOT TO REPRODUCE OR COPY IT		SHEET	
III NOT TO REVEAL OR PUBLISH IT IN WHOLE OR PART		2 OF 42	
IV ALL RIGHTS RESERVED			

Page Notes

Power aliases required by this page:
(NONE)

Signal aliases required by this page:
(NONE)

BOM options provided by this page:

ALL AVAIL BOM OPTIONS

COMMON
ALTERNATE
16GB_PROD
32GB_PROD
64GB_PROD
BKLT_PLL
DEVELOPMENT_JTAG
DEVELOPMENT_JTAG_TAP
JTAG_DAP
JTAG_TAP_NOT
SPEAKER
INTERNAL_MIC
PORTRAIT_DOCK
MLC_DEV
MLC_PROD
K93
K94

BOM GROUP	BOM OPTIONS
BASIC	COMMON, ALTERNATE

ADD DEVELOPMENT AND OTHER BOMS ONCE YOU GET BOM NUMBERS

BOM OPTIONS

PROGRAMMABLE PARTS

SCH AND BOARD P/N

PART#	QTY	DESCRIPTION	REFERENCE DESIGNATOR(S)	BOM OPTION
051-8962	1	SCH_CHOPIN_AUDIO_MLB_K94	SCH1	
820-3069	1	PCBF_CHOPIN_AUDIO_MLB_K94	PCB1	

PD PARTS

PART#	QTY	DESCRIPTION	REFERENCE DESIGNATOR(S)	BOM OPTION
806-1396	1	FENCE_GRAPE_MLB_K93/K94	FENCE1	
806-1397	1	CAN_GRAPE_MLB_K93/K94	CAN1	NOSTUFF
806-1398	1	FENCE_CPU_MLB_K93/K94	FENCE2	
806-1399	1	CAN_CPU_MLB_K93/K94	CAN2	NOSTUFF
806-1400	1	FENCE_MAND_MLB_K93/K94	FENCE3	
806-1401	1	CAN_MAND_MLB_K93/K94	CAN3	NOSTUFF

TOP BARCODE LABEL/EEE CODES (ONLY ONE IS USED PER BOM)

PART#	QTY	DESCRIPTION	REFERENCE DESIGNATOR(S)	CRITICAL	BOM OPTION
825-7651	1	EEEE FOR 639-1180 (K93 16G)	DH36	CRITICAL	EEEE_K93_16G
825-7651	1	EEEE FOR 639-1426 (K93 32G)	DH37	CRITICAL	EEEE_K93_32G
825-7651	1	EEEE FOR 639-1428 (K93 64G)	DG99	CRITICAL	EEEE_K93_64G
825-7651	1	EEEE FOR 639-1112 (K94 16G)	DFC4	CRITICAL	EEEE_K94_16G
825-7651	1	EEEE FOR 639-1181 (K94 32G)	DFC5	CRITICAL	EEEE_K94_32G
825-7651	1	EEEE FOR 639-1182 (K94 64G)	DFC6	CRITICAL	EEEE_K94_64G
825-7651	1	EEEE FOR 639-1430 (K95 16G)	DH3C	CRITICAL	EEEE_K95_16G
825-7651	1	EEEE FOR 639-1427 (K95 32G)	DH3D	CRITICAL	EEEE_K95_32G
825-7651	1	EEEE FOR 639-1429 (K95 64G)	DG9C	CRITICAL	EEEE_K95_64G

BOTTOM LABEL TYPE 1

PART#	QTY	DESCRIPTION	REFERENCE DESIGNATOR(S)	CRITICAL	BOM OPTION
825-7639	1	631- B/C LABEL	LBL1	CRITICAL	
825-7639	1	639- B/C LABEL	LBL2	CRITICAL	

BOTTOM LABEL TYPE 2

PART#	QTY	DESCRIPTION	REFERENCE DESIGNATOR(S)	CRITICAL	BOM OPTION
825-7640	1	MATRIX LABEL	LBL3	CRITICAL	
825-7640	1	631- MATRIX LABEL	LBL4	CRITICAL	

www.laptop-schematics.com

SYNC MASTER=MIKE		SYNC DATE=N/A	
BOM TABLE			
 Apple Inc.	DRAWING NUMBER	051-8962	SIZE D
	REVISION	A.0.0	BRANCH
NOTICE OF PROPRIETARY PROPERTY: THE INFORMATION CONTAINED HEREIN IS THE PROPRIETARY PROPERTY OF APPLE COMPUTER, INC. THE POSSESSOR AGREES TO THE FOLLOWING: I TO MAINTAIN THIS DOCUMENT IN CONFIDENCE II NOT TO REPRODUCE OR COPY IT III NOT TO REVEAL OR PUBLISH IT IN WHOLE OR PART IV ALL RIGHTS RESERVED			PAGE 5 OF 106
			SHEET 3 OF 42

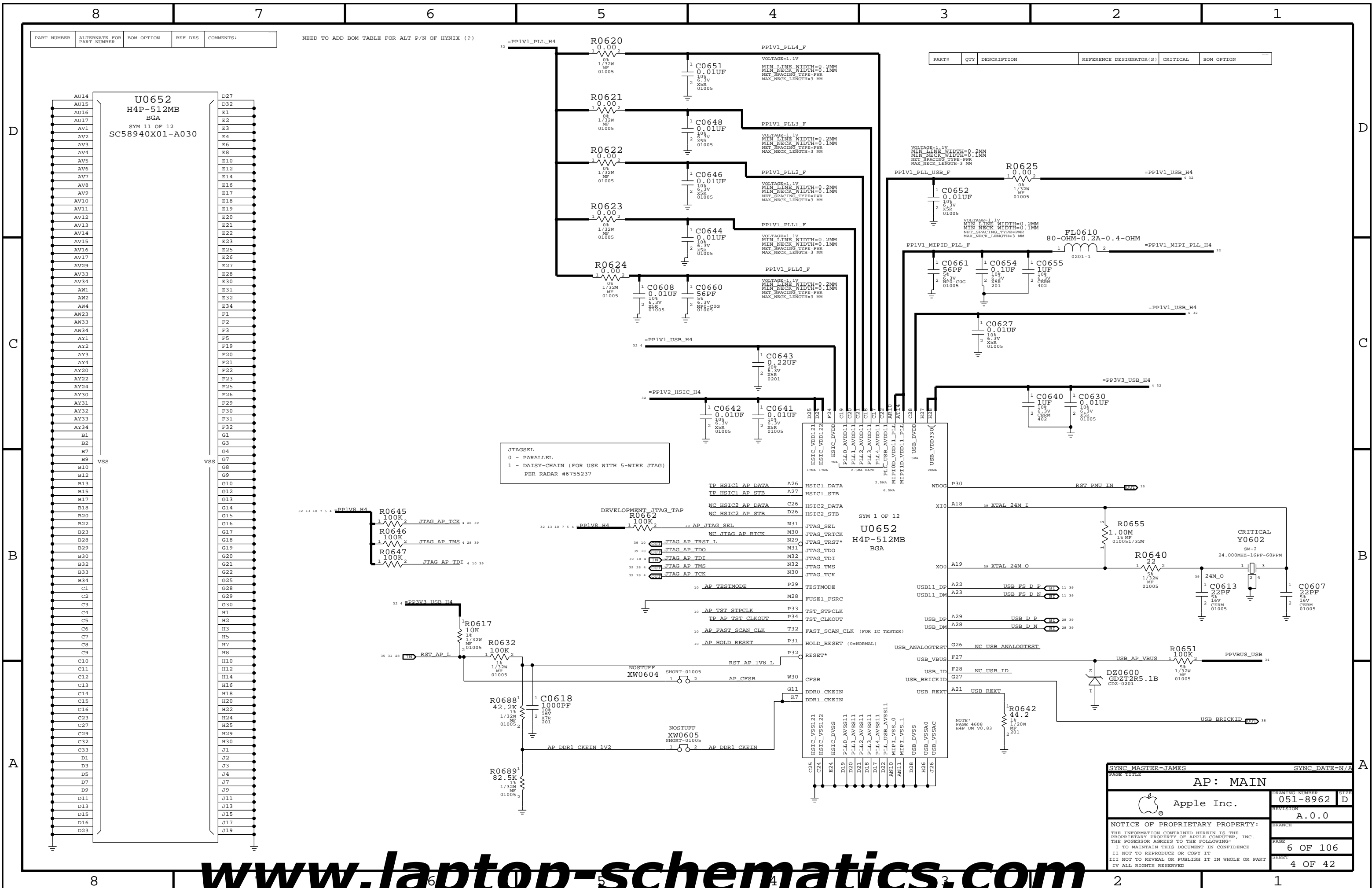

PART NUMBER	ALTERNATE FOR PART NUMBER	BOM OPTION	REF DES	COMMENTS:
-------------	---------------------------	------------	---------	-----------

NEED TO ADD BOM TABLE FOR ALT P/N OF HYNIX (?)

PART#	QTY	DESCRIPTION	REFERENCE DESIGNATOR(S)	CRITICAL	BOM OPTION
-------	-----	-------------	-------------------------	----------	------------

U0652
H4P-512MB
BGA
SYM 11 OF 12
SC58940X01-A030

JTAGSEL
0 - PARALLEL
1 - DAISY-CHAIN (FOR USE WITH 5-WIRE JTAG)
PER RADAR #6755237

DEVELOPMENT JTAG TAP

SYM 11 OF 12
U0652
H4P-512MB
BGA

PAGE TITLE		SYNC DATE=N/A	
AP: MAIN			
Apple Inc.	DRAWING NUMBER	051-8962	SIZE D
	REVISION	A.0.0	
NOTICE OF PROPRIETARY PROPERTY:			
THE INFORMATION CONTAINED HEREIN IS THE PROPRIETARY PROPERTY OF APPLE COMPUTER, INC. THE POSSESSOR AGREES TO THE FOLLOWING:			
I TO MAINTAIN THIS DOCUMENT IN CONFIDENCE			
II NOT TO REPRODUCE OR COPY IT			
III NOT TO REVEAL OR PUBLISH IT IN WHOLE OR PART			
IV ALL RIGHTS RESERVED			
PAGE	6 OF 106	SHEET	4 OF 42

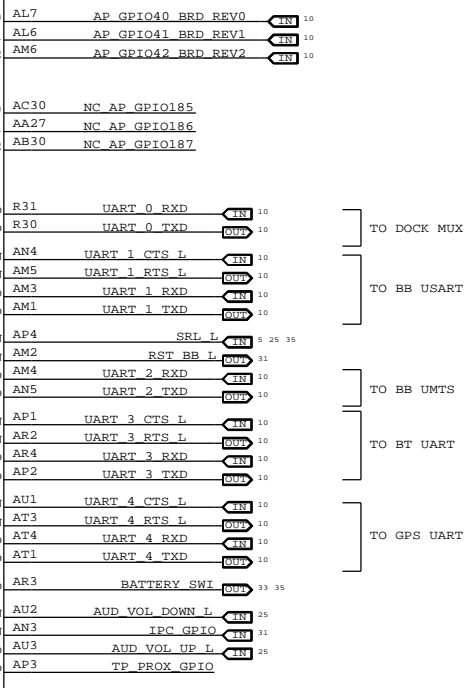
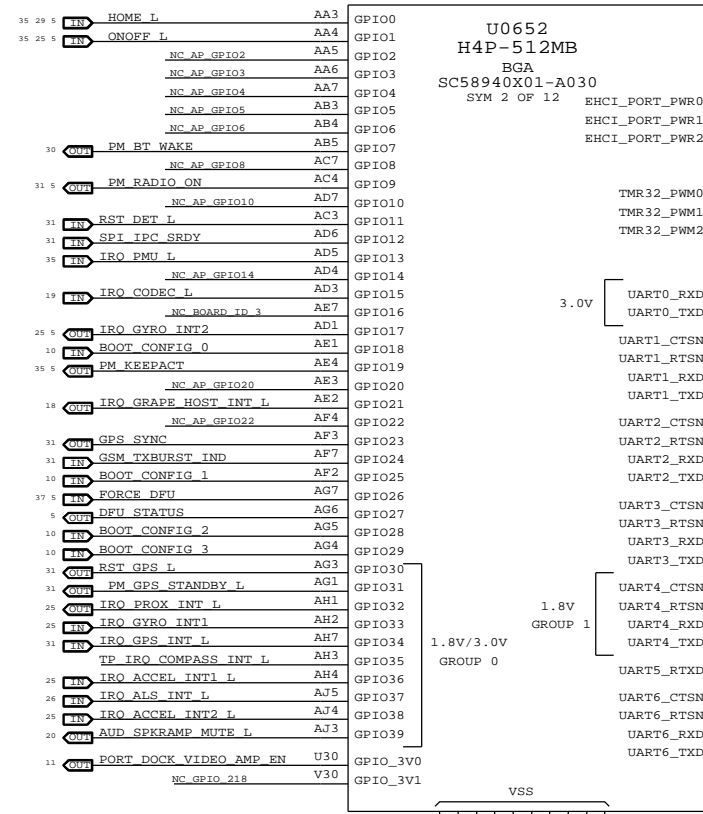
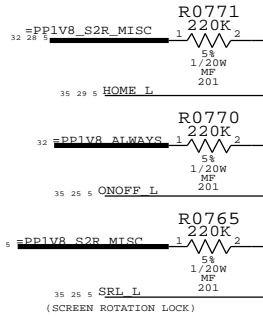
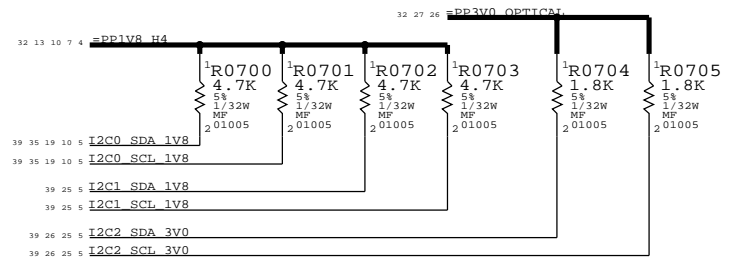

www.laptop-schematics.com

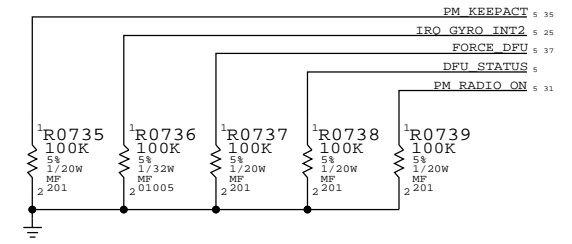
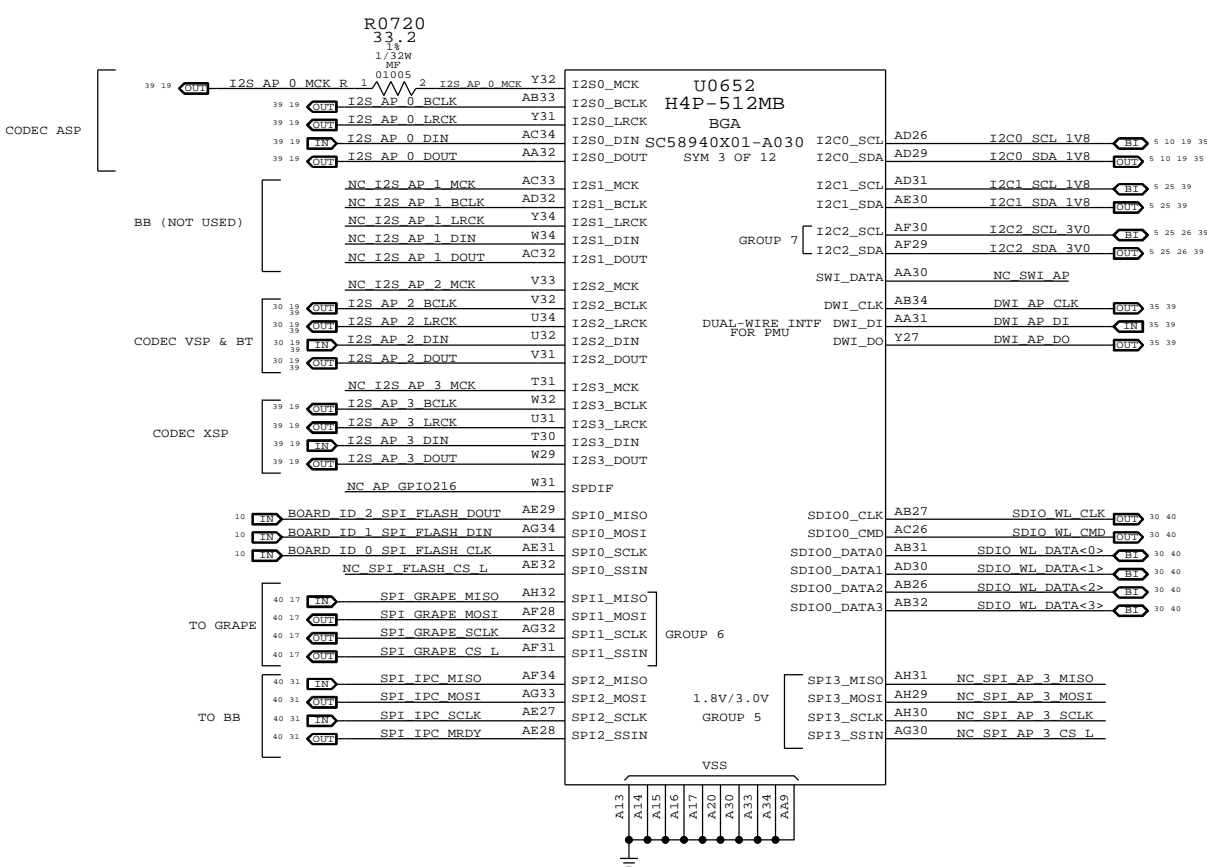

PAGE TITLE		SYNC DATE=N/A	
AP: I/Os			
Apple Inc.	DRAWING NUMBER	051-8962	SIZE
	REVISION	A.0.0	
NOTICE OF PROPRIETARY PROPERTY:		BRANCH	
THE INFORMATION CONTAINED HEREIN IS THE PROPRIETARY PROPERTY OF APPLE COMPUTER, INC. THE POSSESSOR AGREES TO THE FOLLOWING:		PAGE	
I TO MAINTAIN THIS DOCUMENT IN CONFIDENCE		7 OF 106	
II NOT TO REPRODUCE OR COPY IT		SHEET	
III NOT TO REVEAL OR PUBLISH IT IN WHOLE OR PART		5 OF 42	
IV ALL RIGHTS RESERVED			

D

D

C

C

B

B

A

A

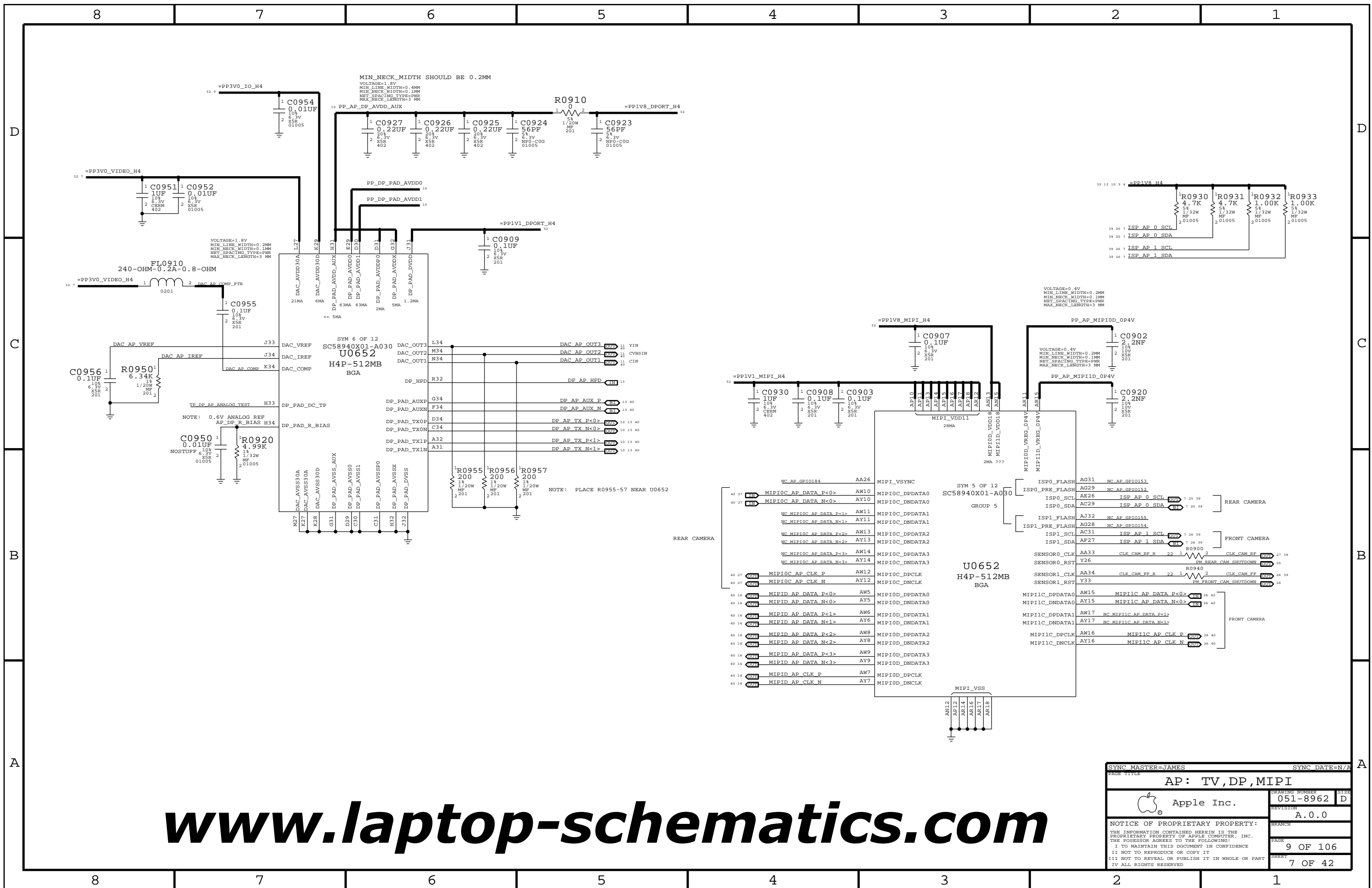

www.laptop-schematics.com

SYNC MASTER=JAMES		SYNC DATE=N/A	
PAGE TITLE			
AP: TV, DP, MIPI			
Apple Inc.	DRAWING NUMBER	051-8962	SIZE
	REVISION	A.0.0	
NOTICE OF PROPRIETARY PROPERTY:			
THE INFORMATION CONTAINED HEREIN IS THE PROPRIETARY PROPERTY OF APPLE COMPUTER, INC. THE POSSESSOR AGREES TO THE FOLLOWING:			
I TO MAINTAIN THIS DOCUMENT IN CONFIDENCE			
II NOT TO REPRODUCE OR COPY IT			
III NOT TO REVEAL OR PUBLISH IT IN WHOLE OR PART			
IV ALL RIGHTS RESERVED			
BRANCH	PAGE	9 OF 106	SHEET
			7 OF 42

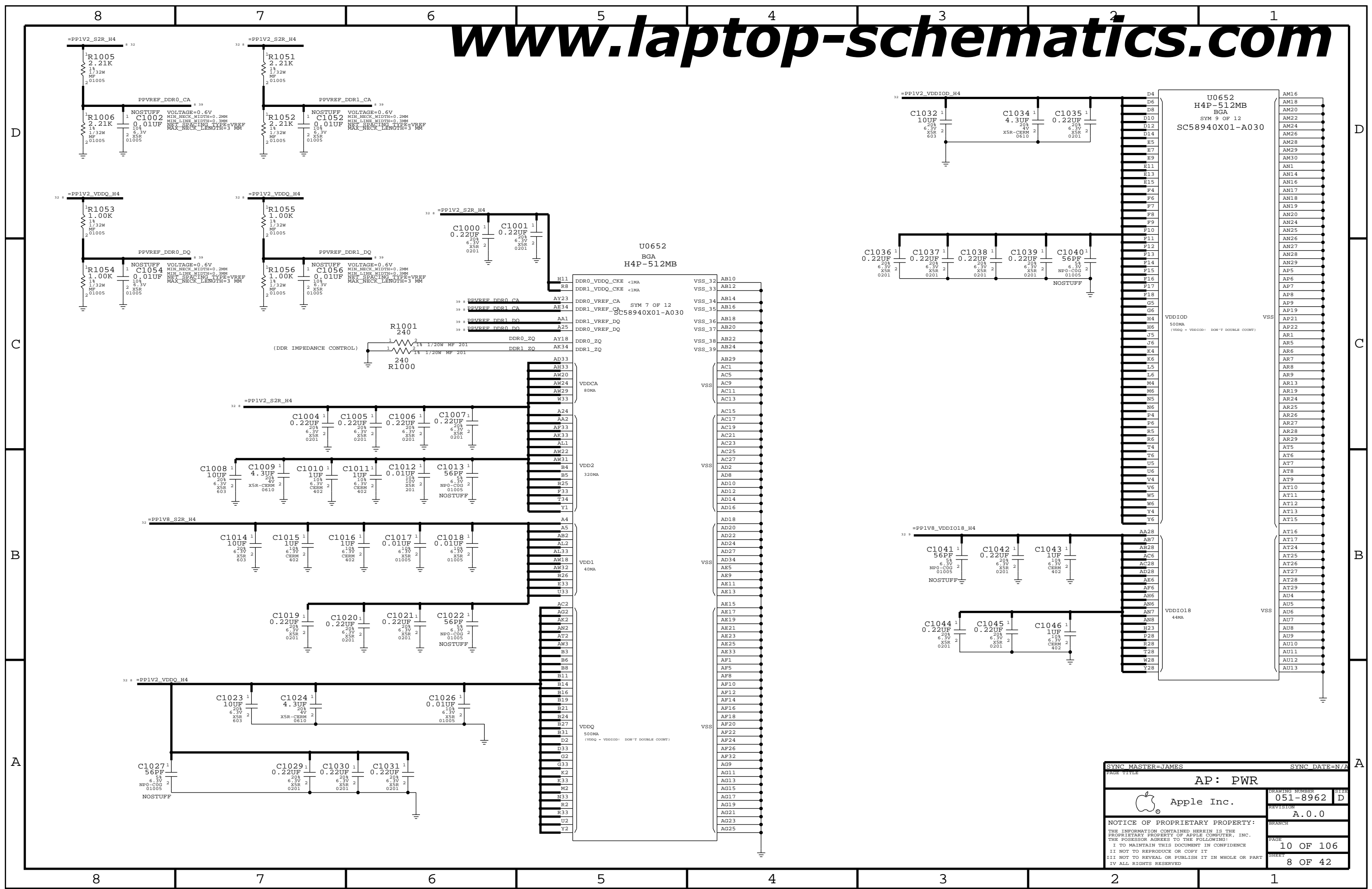

SYNC MASTER=JAMES		SYNC DATE=N/A	
PAGE TITLE			
AP: PWR		DRAWING NUMBER	SIZE
Apple Inc.		051-8962	D
NOTICE OF PROPRIETARY PROPERTY: THE INFORMATION CONTAINED HEREIN IS THE PROPRIETARY PROPERTY OF APPLE COMPUTER, INC. THE POSSESSOR AGREES TO THE FOLLOWING: I TO MAINTAIN THIS DOCUMENT IN CONFIDENCE II NOT TO REPRODUCE OR COPY IT III NOT TO REVEAL OR PUBLISH IT IN WHOLE OR PART IV ALL RIGHTS RESERVED		REVISION	BRANCH
		A.0.0	
		PAGE	SHEET
		10 OF 106	8 OF 42

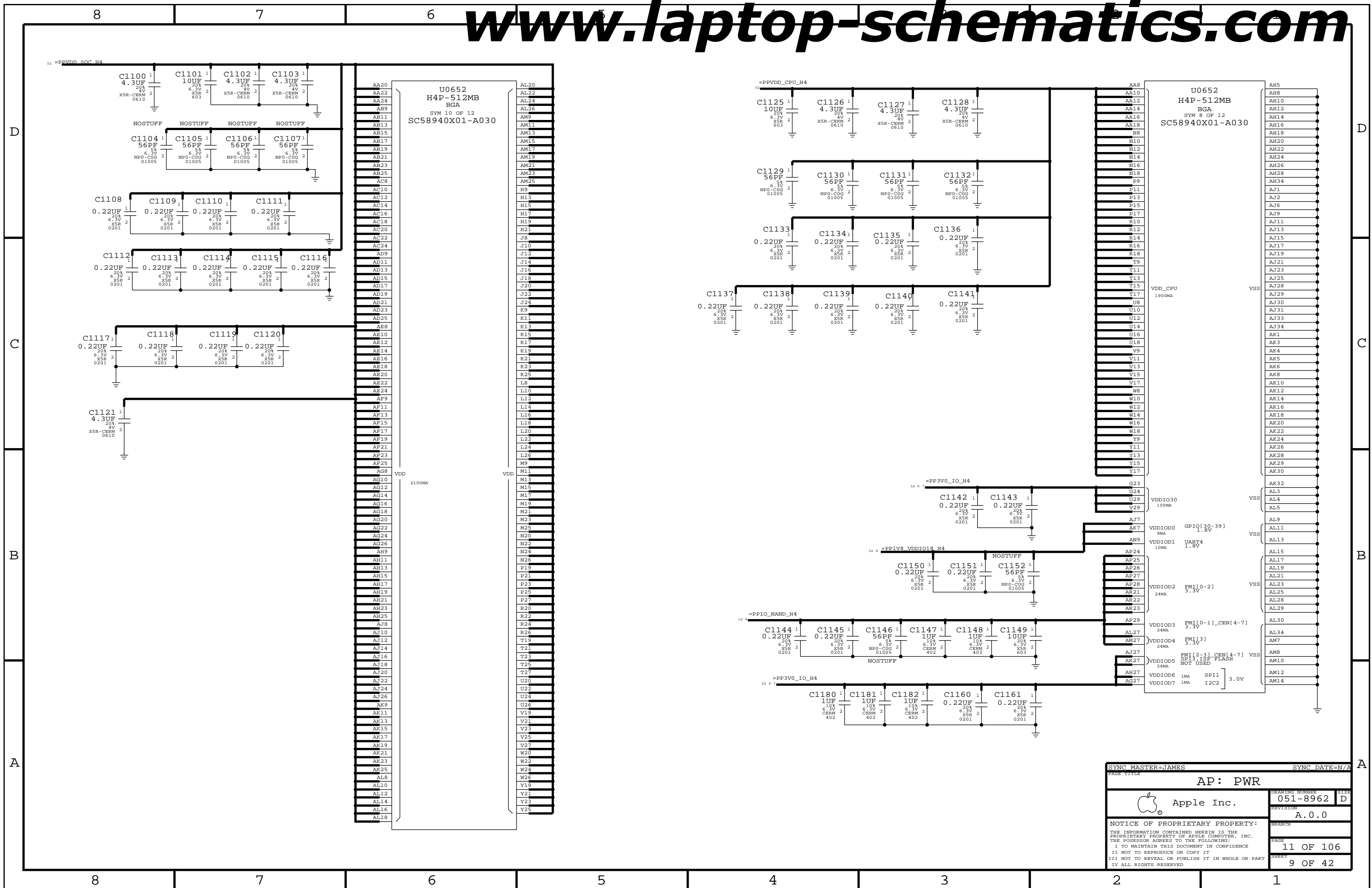

SYNC MASTER=JAMES		SYNC DATE=N/A	
AP: PWR			
Apple Inc.	DRAWING NUMBER	051-8962	SIZE D
	REVISION	A.0.0	
NOTICE OF PROPRIETARY PROPERTY: THE INFORMATION CONTAINED HEREIN IS THE PROPRIETARY PROPERTY OF APPLE COMPUTER, INC. THE POSSESSOR AGREES TO THE FOLLOWING: I TO MAINTAIN THIS DOCUMENT IN CONFIDENCE II NOT TO REPRODUCE OR COPY IT III NOT TO REVEAL OR PUBLISH IT IN WHOLE OR PART IV ALL RIGHTS RESERVED			
PAGE		11 OF 106	
SHEET		9 OF 42	

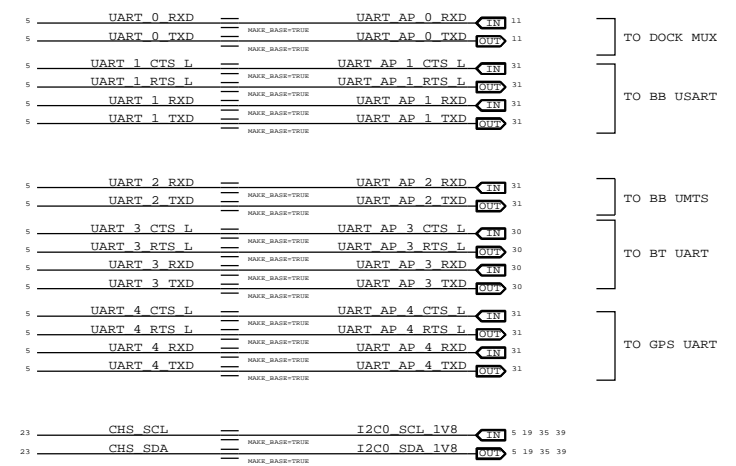
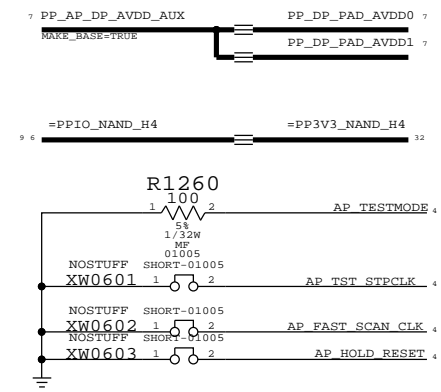
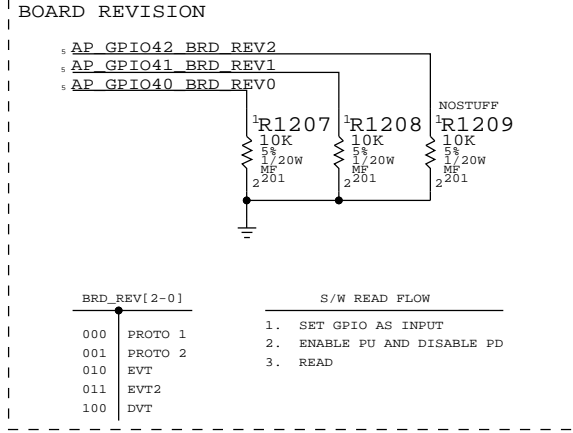
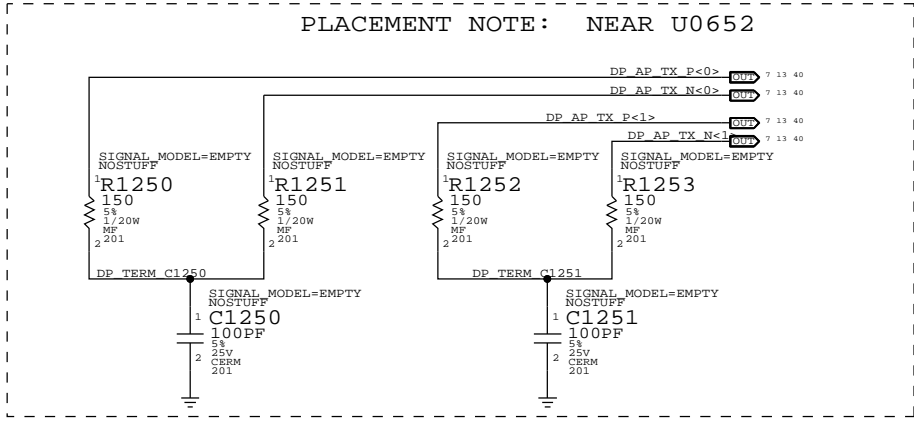
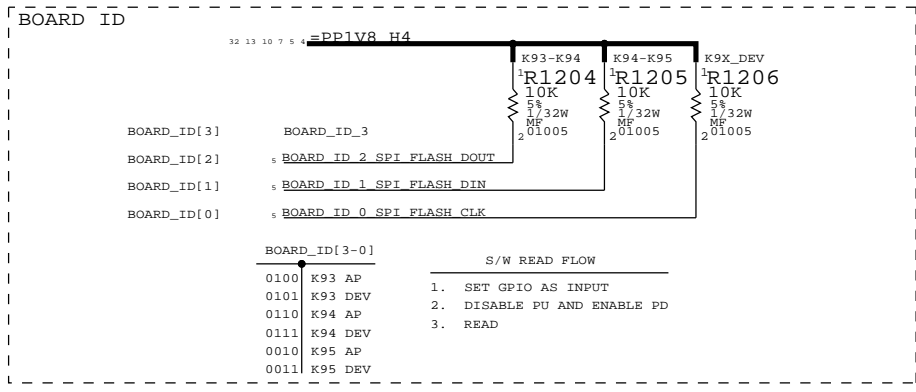
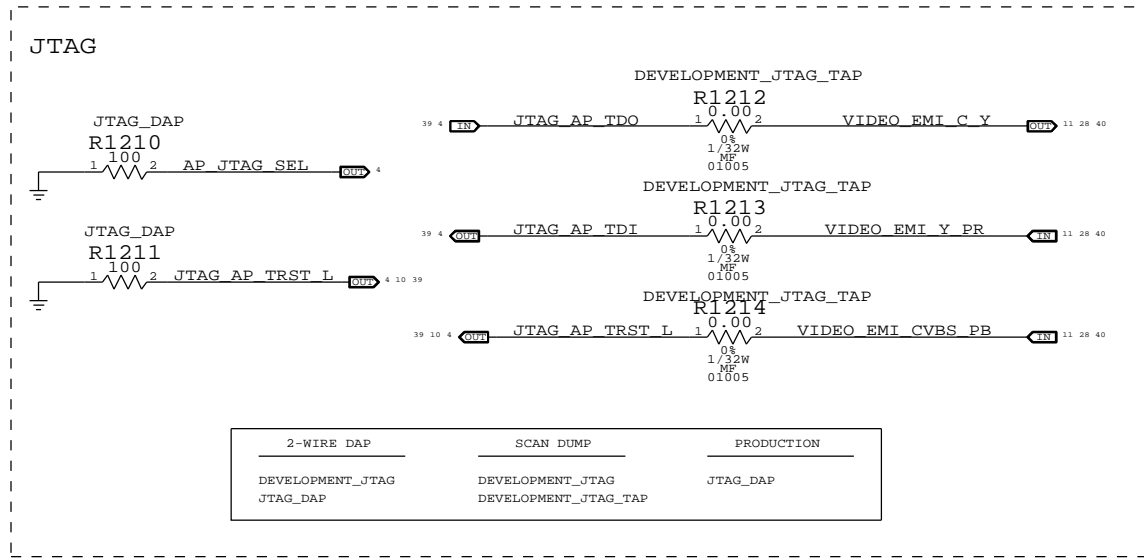
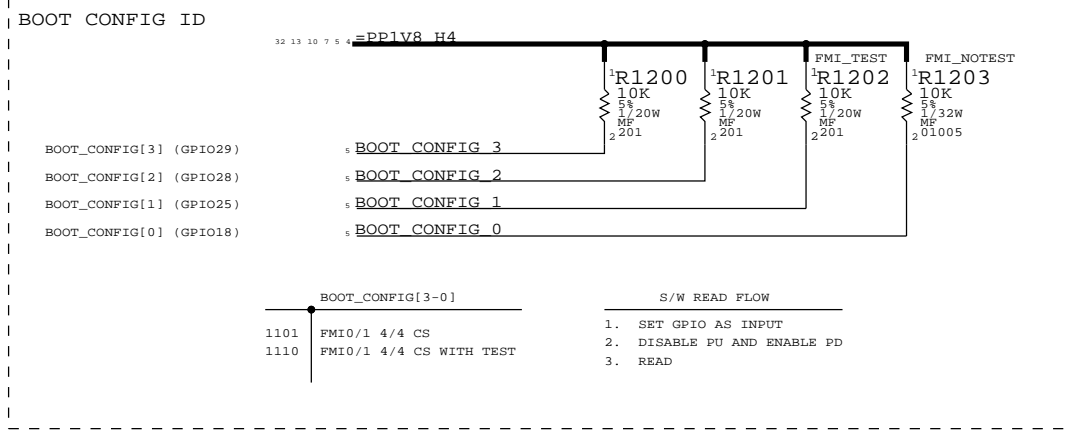

FOR REFERENCE

BOOT_CONFIG[3:0]	
0000	SPI0
0001	SPI3
0010	SPIO W/TEST
0011	SPI3 W/TEST
0100	FMIO 2CS
0101	FMIO 4CS
0110	FMIO 4CS W/TEST
0111	RESERVED
1000	FMII 2 CS
1001	FMII 4 CS
1010	FMII 4CS W/TEST
1011	RESERVED
1100	FMIO/1 2/2 CS
1101	FMIO/1 4/4 CS
1110	FMIO/1 4/4 CS W/TEST
1111	RESERVED

CURRENT SETTING ->

SYNC MASTER=JAMES		SYNC DATE=N/A	
AP: MISC & ALIASES			
Apple Inc.		DRAWING NUMBER	051-8962
		REVISION	A.0.0
NOTICE OF PROPRIETARY PROPERTY:		BRANCH	
THE INFORMATION CONTAINED HEREIN IS THE PROPRIETARY PROPERTY OF APPLE COMPUTER, INC. THE POSSESSOR AGREES TO THE FOLLOWING:		PAGE	12 OF 106
I TO MAINTAIN THIS DOCUMENT IN CONFIDENCE		SHEET	10 OF 42
II NOT TO REPRODUCE OR COPY IT			
III NOT TO REVEAL OR PUBLISH IT IN WHOLE OR PART			
IV ALL RIGHTS RESERVED			

NOTE:
LDO3 PROVIDES 50MA TO BOTH H4P AND U1300
IF THAT'S NOT ENOUGH, STUFF R1371 AND NOSTUFF R1370

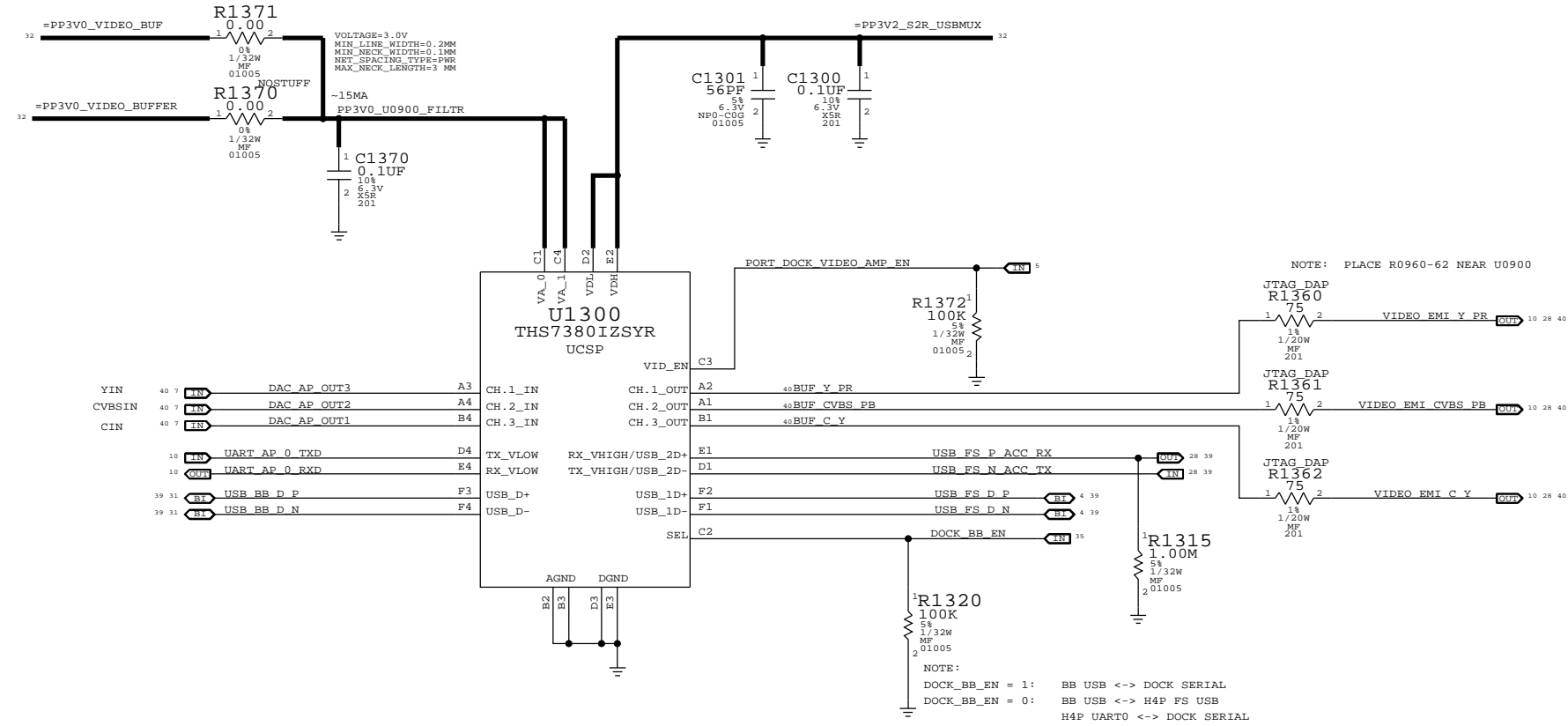

www.laptop-schematics.com

SYNC MASTER=JAMES		SYNC DATE=N/A	
PAGE TITLE AP: VIDEO BUFFER, BB USB MUXES			
Apple Inc.	DRAWING NUMBER	051-8962	SIZE D
	REVISION	A.0.0	BRANCH
NOTICE OF PROPRIETARY PROPERTY: THE INFORMATION CONTAINED HEREIN IS THE PROPRIETARY PROPERTY OF APPLE COMPUTER, INC. THE POSSESSOR AGREES TO THE FOLLOWING: I TO MAINTAIN THIS DOCUMENT IN CONFIDENCE II NOT TO REPRODUCE OR COPY IT III NOT TO REVEAL OR PUBLISH IT IN WHOLE OR PART IV ALL RIGHTS RESERVED			PAGE 13 OF 106
			SHEET 11 OF 42

DISPLAYPORT AC COUPLING

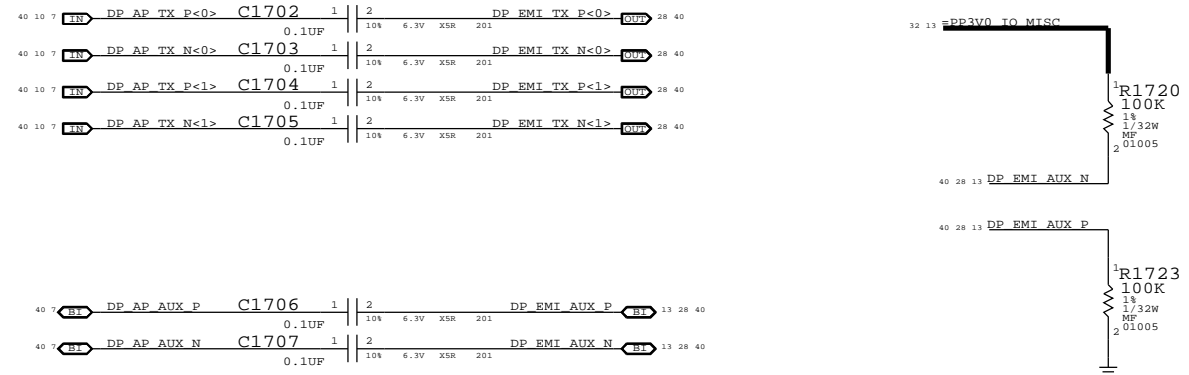

DISPLAYPORT HOT PLUG DETECT

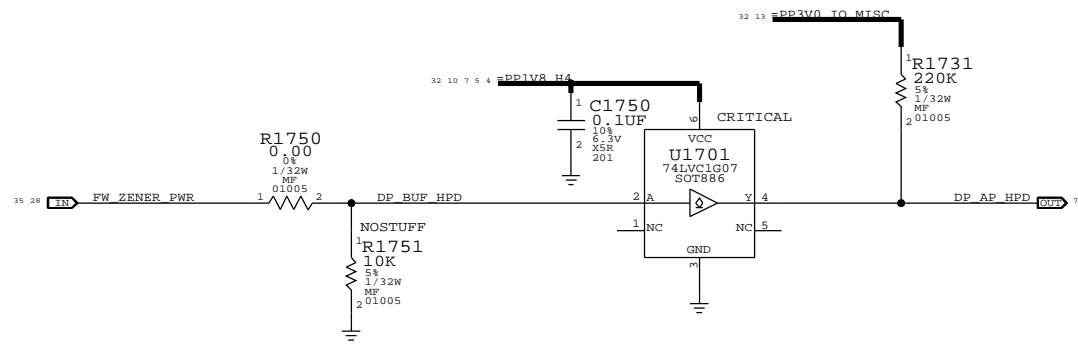

PART NUMBER	ALTERNATE FOR PART NUMBER	BOM OPTION	REF DES	COMMENTS:
311S0536	311S0341		U1701	RADAR:8481319

www.laptop-schematics.com

SYNC MASTER=JAMES		SYNC DATE=N/A	
PAGE TITLE VIDEO: DISPLAY PORT			
DRAWING NUMBER 051-8962		SIZE D	
REVISION A.0.0		BRANCH	
NOTICE OF PROPRIETARY PROPERTY: THE INFORMATION CONTAINED HEREIN IS THE PROPRIETARY PROPERTY OF APPLE COMPUTER, INC. THE POSSESSOR AGREES TO THE FOLLOWING: I TO MAINTAIN THIS DOCUMENT IN CONFIDENCE II NOT TO REPRODUCE OR COPY IT III NOT TO REVEAL OR PUBLISH IT IN WHOLE OR PART IV ALL RIGHTS RESERVED			
PAGE 17 OF 106		SHEET 13 OF 42	

MLC EEPROM:RAW APN 335S0661

PART#	QTY	DESCRIPTION	REFERENCE DESIGNATOR(S)	CRITICAL	BOM OPTION
341S2799	1	MLC EEPROM 100MHZ LVDS,2MHZ SWI	U2001	CRITICAL	100MHZ_PANEL

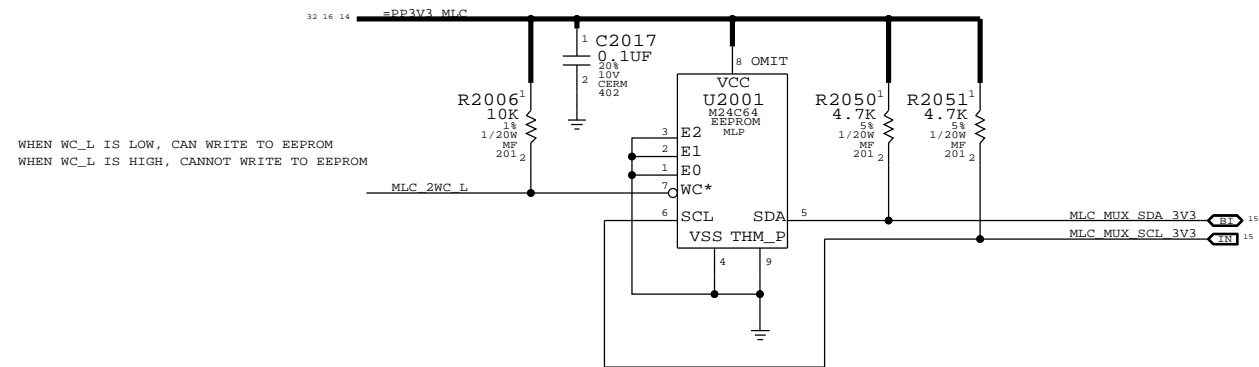

www.laptop-schematics.com

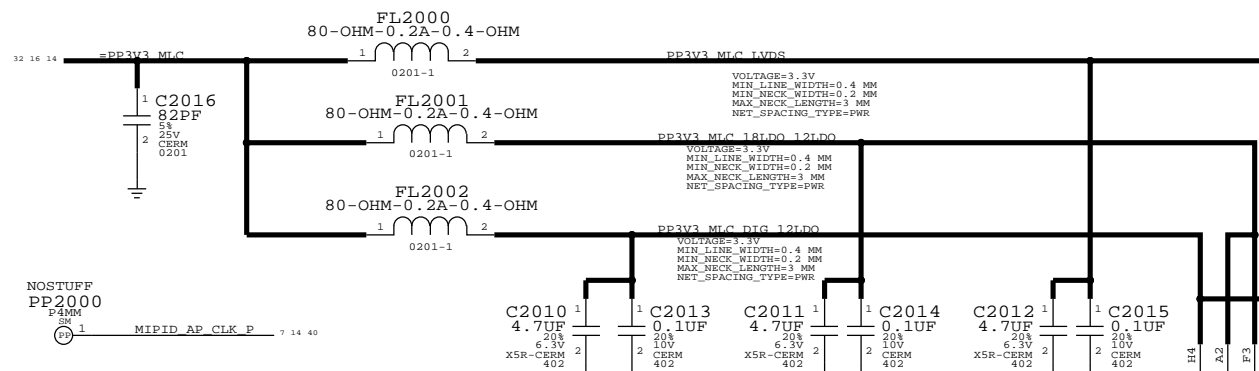

PART NUMBER	ALTERNATE FOR PART NUMBER	BOM OPTION	REF DES	COMMENTS:
138S0652	138S0618			RADAR:8377307

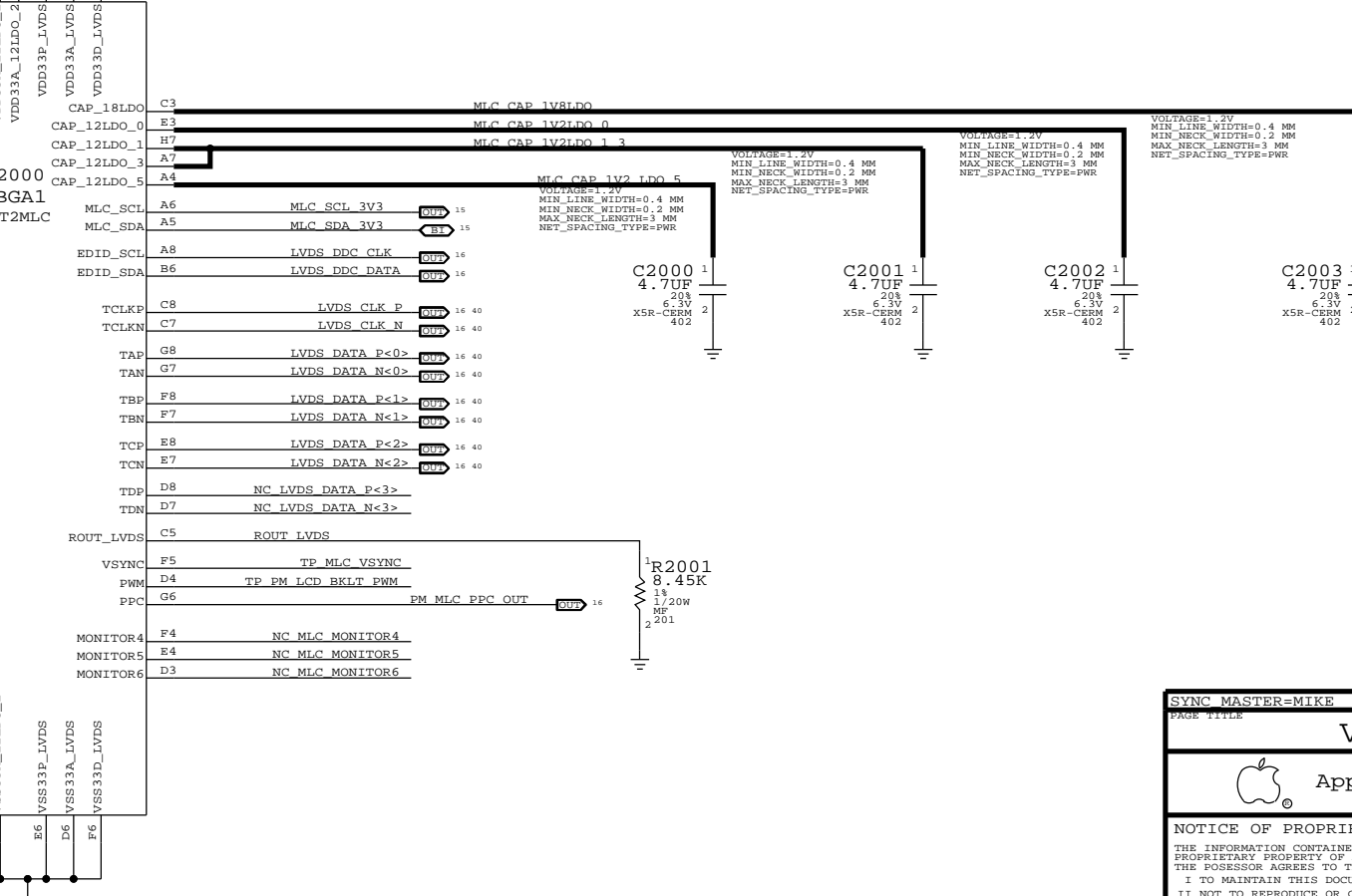
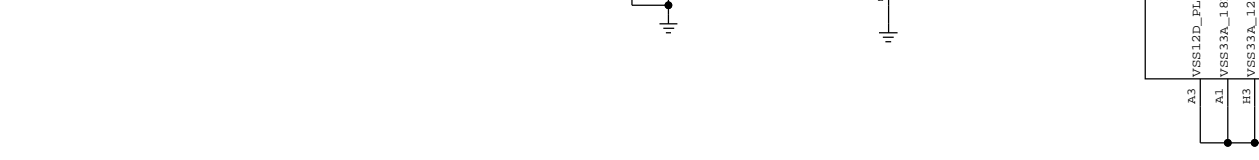
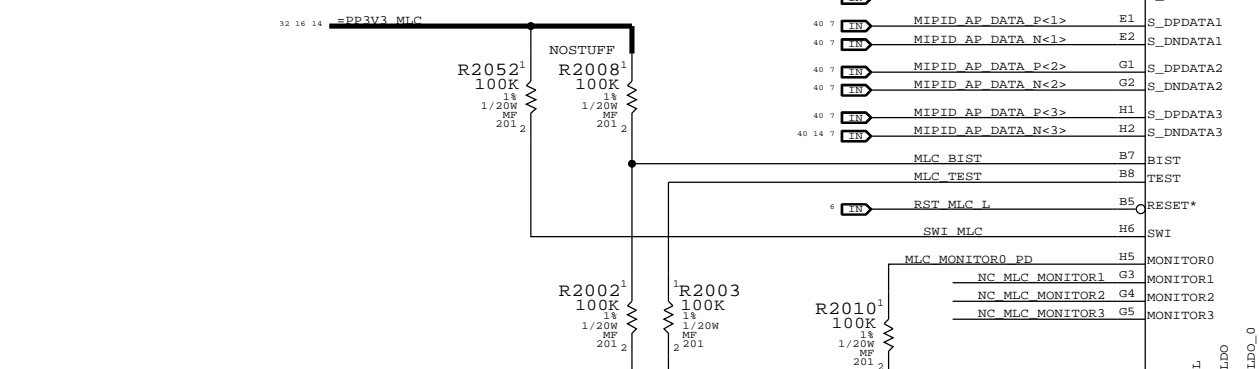
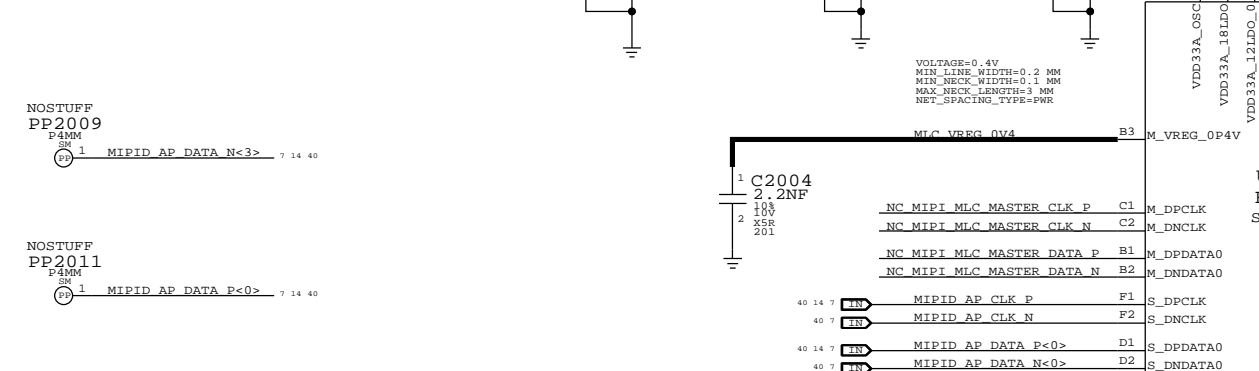

PAGE TITLE		SYNC DATE=N/A	
VIDEO: MLC			
Apple Inc.		DRAWING NUMBER	SIZE
		051-8962	D
		REVISION	
		A.0.0	
NOTICE OF PROPRIETARY PROPERTY:			
THE INFORMATION CONTAINED HEREIN IS THE PROPRIETARY PROPERTY OF APPLE COMPUTER, INC. THE POSSESSOR AGREES TO THE FOLLOWING:			
I TO MAINTAIN THIS DOCUMENT IN CONFIDENCE			
II NOT TO REPRODUCE OR COPY IT			
III NOT TO REVEAL OR PUBLISH IT IN WHOLE OR PART			
IV ALL RIGHTS RESERVED			
PAGE		SHEET	
20 OF 106		14 OF 42	

8

7

6

5

4

3

2

1

D

D

C

C

B

B

A

A

14 MLC_SDA_3V3 MLC_MUX_SDA_3V3 14
 14 MLC_SCL_3V3 MLC_MUX_SCL_3V3 14

www.laptop-schematics.com

SYNC MASTER=MIKE		SYNC DATE=N/A	
VIDEO: MLC ALIASES			
 Apple Inc.	DRAWING NUMBER	051-8962	
	REVISION	A.0.0	
NOTICE OF PROPRIETARY PROPERTY:		BRANCH	
THE INFORMATION CONTAINED HEREIN IS THE PROPRIETARY PROPERTY OF APPLE COMPUTER, INC. THE POSSESSOR AGREES TO THE FOLLOWING: I TO MAINTAIN THIS DOCUMENT IN CONFIDENCE II NOT TO REPRODUCE OR COPY IT III NOT TO REVEAL OR PUBLISH IT IN WHOLE OR PART IV ALL RIGHTS RESERVED		PAGE	21 OF 106
		SHEET	15 OF 42

8

7

6

5

4

3

2

1

LVDS CONNECTOR

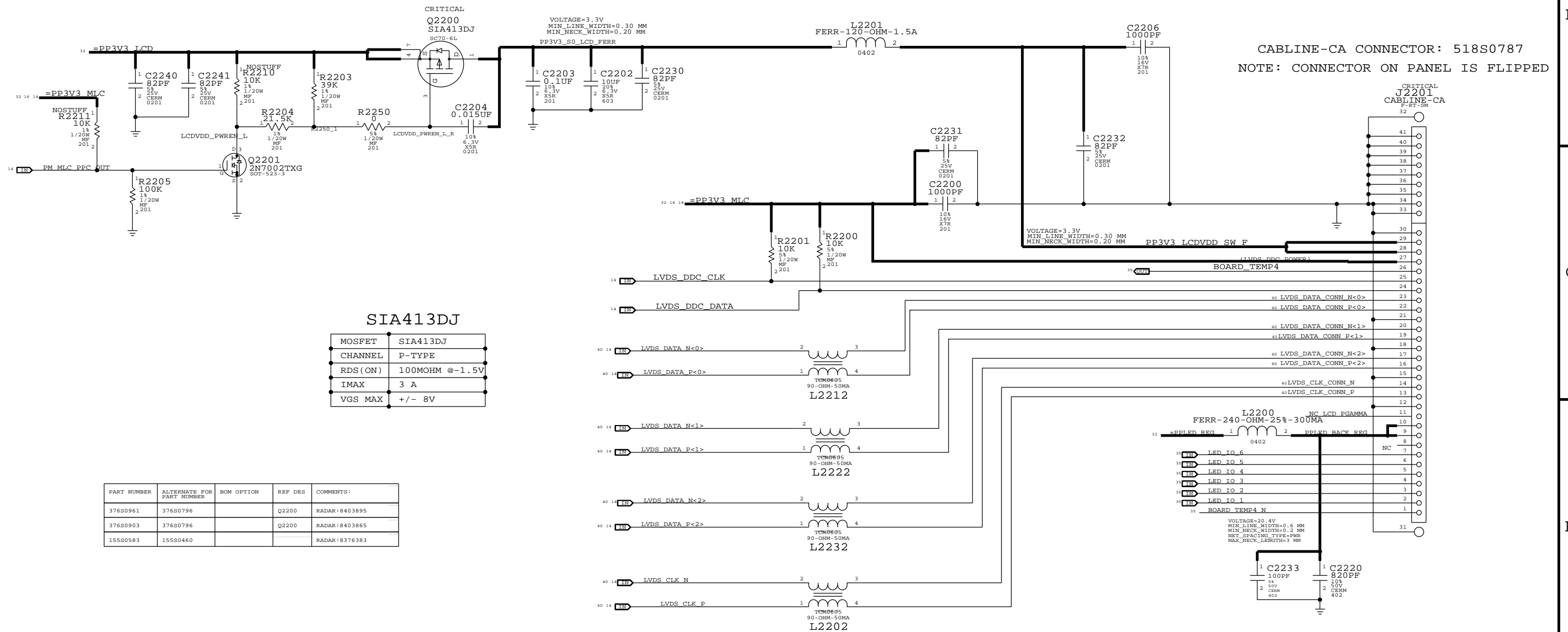

PART NUMBER	ALTERNATE FOR PART NUMBER	BOM OPTION	REF DES	COMMENTS:
376S0961	376S0796		Q2200	RADAR:8403895
376S0903	376S0796		Q2200	RADAR:8403865
155S0583	155S0460			RADAR:8376383

NOSTUFF RESISTORS ARE THERE TO INVESTIGATE POSSIBILITY OF REMOVING THE CHOKE

www.laptop-schematics.com

SYNC MASTER=ALEX		SYNC DATE=N/A	
PAGE TITLE VIDEO: LVDS CONNECTOR			
Apple Inc.		DRAWING NUMBER 051-8962	SIZE D
NOTICE OF PROPRIETARY PROPERTY: THE INFORMATION CONTAINED HEREIN IS THE PROPRIETARY PROPERTY OF APPLE COMPUTER, INC. THE POSSESSOR AGREES TO THE FOLLOWING: I TO MAINTAIN THIS DOCUMENT IN CONFIDENCE II NOT TO REPRODUCE OR COPY IT III NOT TO REVEAL OR PUBLISH IT IN WHOLE OR PART IV ALL RIGHTS RESERVED		REVISION A.0.0	BRANCH
		PAGE 22 OF 106	SHEET 16 OF 42

PART#	QTY	DESCRIPTION	REFERENCE DESIGNATOR(S)	CRITICAL	BOM OPTION
34380525	1	IC,ASIC,GROUNDHOG B0,120B BGA	U3003	CRITICAL	

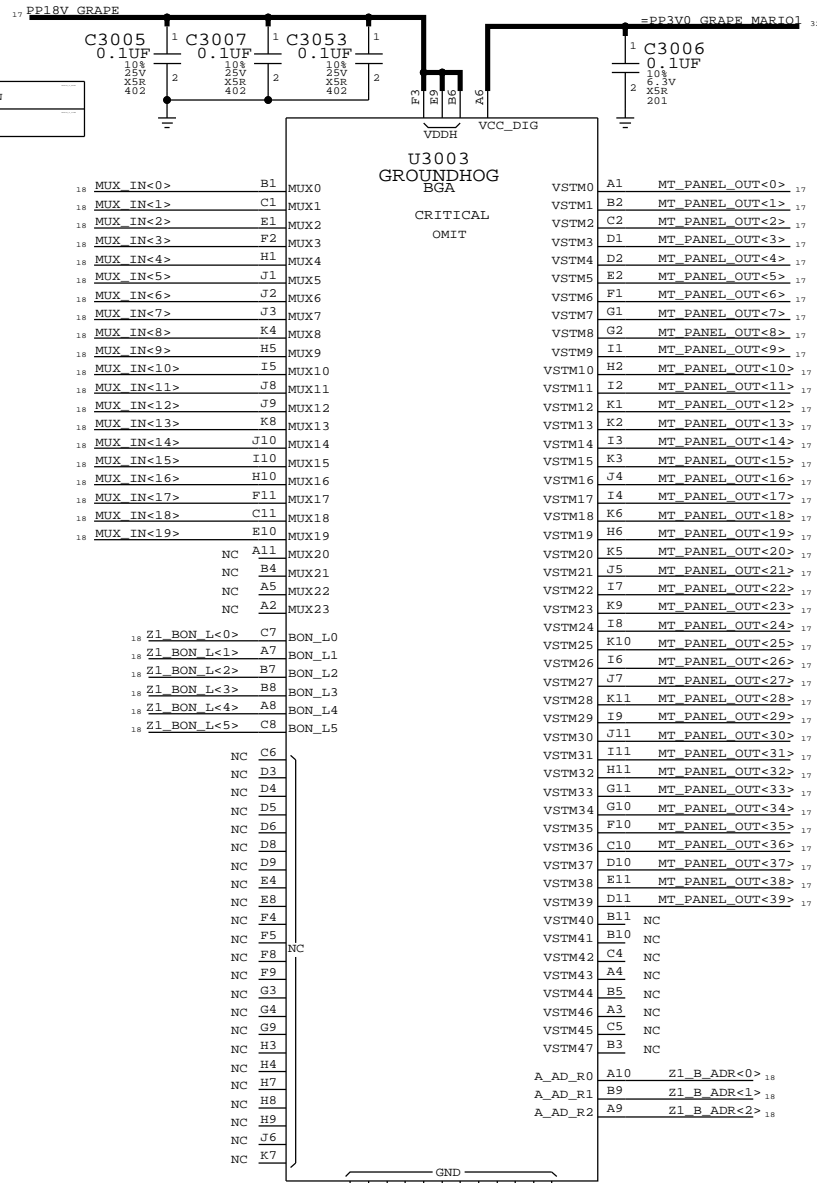

CONNECTORS TO GRAPE FLEX

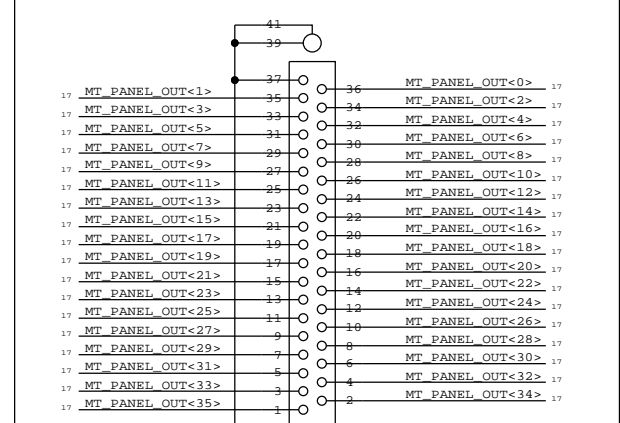
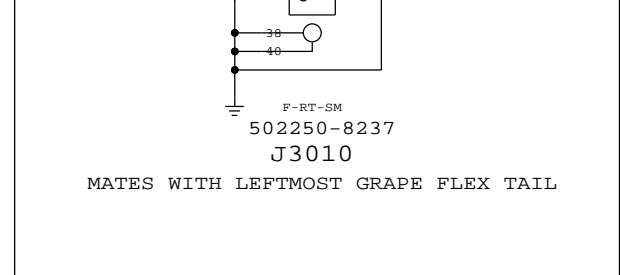
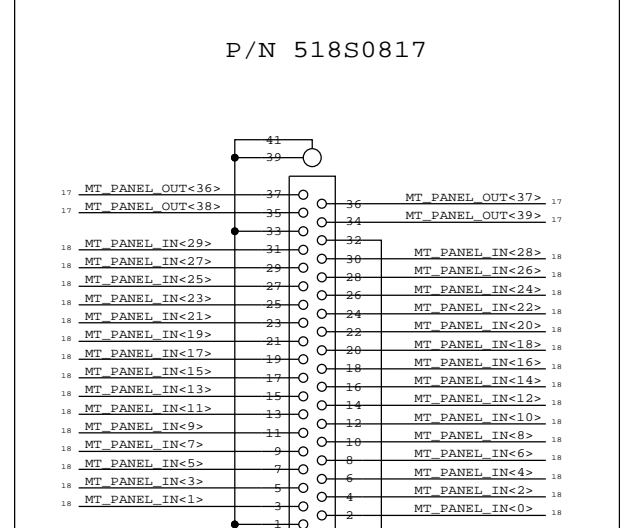

BOOST CONVERTOR

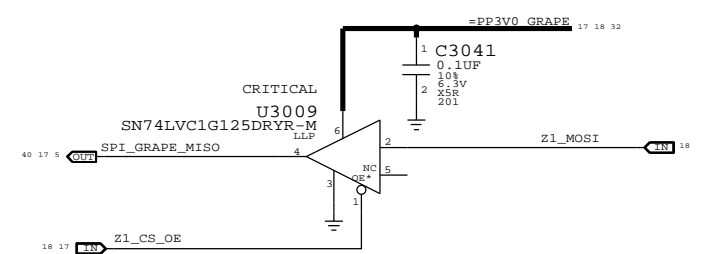
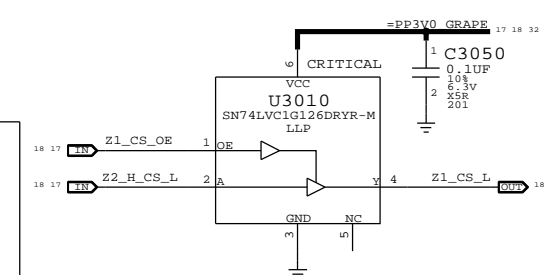
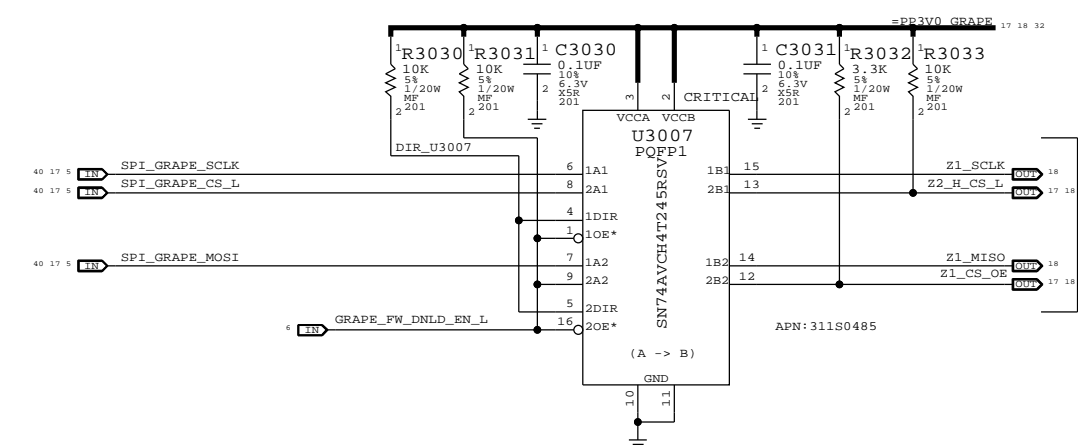
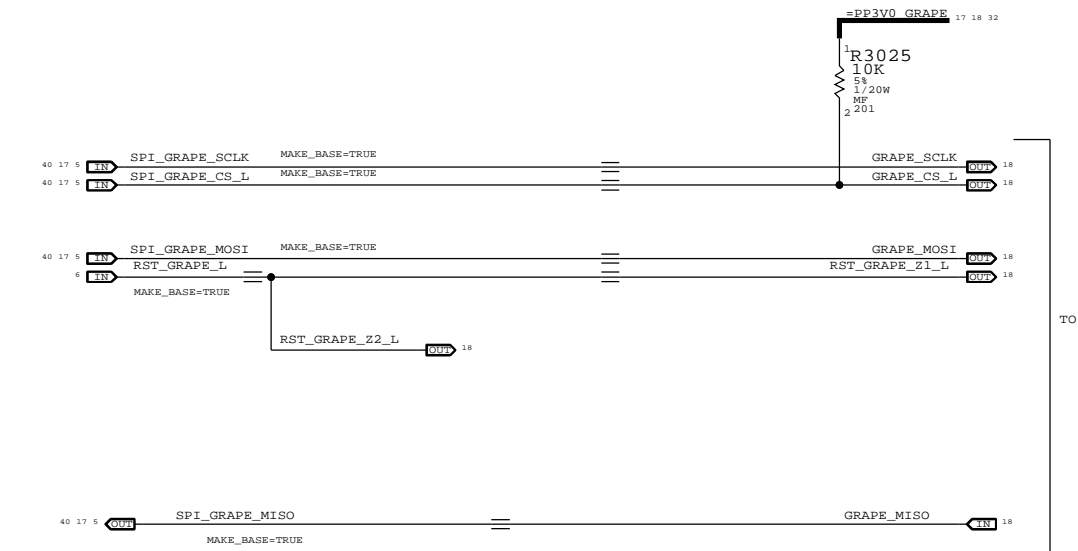
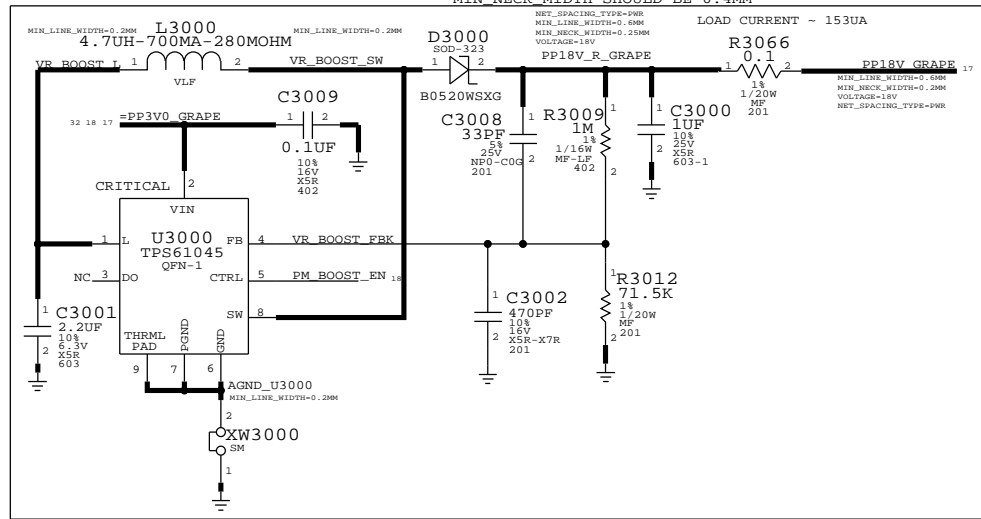

PART NUMBER	ALTERNATE FOR PART NUMBER	BOM OPTION	REF DES	COMMENTS:
31150523	31150485		U3007	
31150524	31150533		U3009	
31150525	31150532		U3010	

SYNC MASTER=RAMSIN SYNC DATE=N/A

GRAPE: GROUNDHOG, CONN, BOOST

Apple Inc.

DRAWING NUMBER: 051-8962 SIZE: D

REVISION: A.0.0

NOTICE OF PROPRIETARY PROPERTY: THE INFORMATION CONTAINED HEREIN IS THE PROPRIETARY PROPERTY OF APPLE COMPUTER, INC. THE POSSESSOR AGREES TO THE FOLLOWING: I TO MAINTAIN THIS DOCUMENT IN CONFIDENCE III NOT TO REPRODUCE OR COPY IT III NOT TO REVEAL OR PUBLISH IT IN WHOLE OR PART IV ALL RIGHTS RESERVED

PAGE: 30 OF 106 SHEET: 17 OF 42

L63 AUDIO CODEC

APN:338S0940

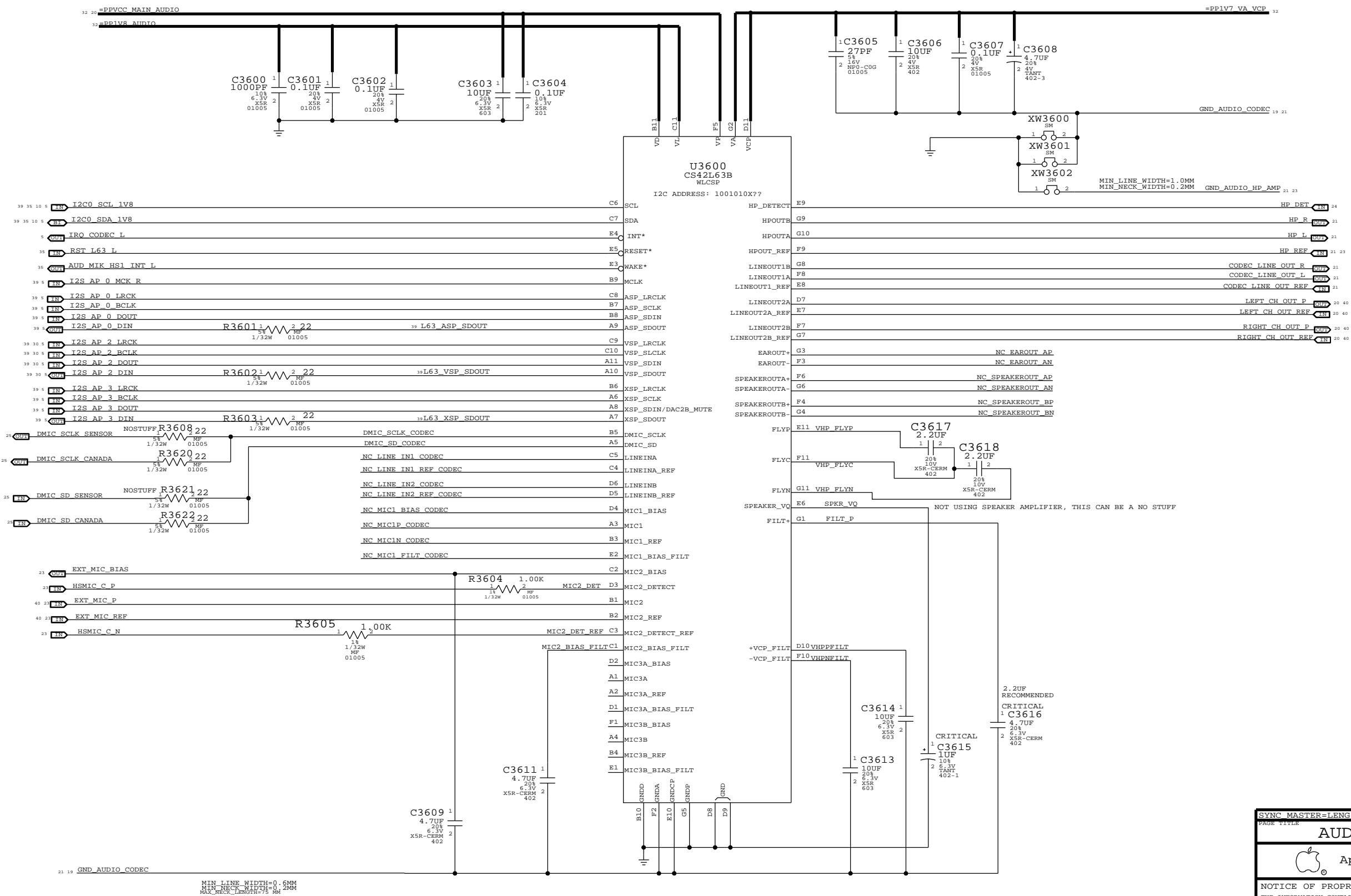

SYNC MASTER=LENG		SYNC DATE=N/A	
AUDIO: L63 CODEC			
Apple Inc.		DRAWING NUMBER	SIZE
NOTICE OF PROPRIETARY PROPERTY: THE INFORMATION CONTAINED HEREIN IS THE PROPRIETARY PROPERTY OF APPLE COMPUTER, INC. THE POSSESSOR AGREES TO THE FOLLOWING: I TO MAINTAIN THIS DOCUMENT IN CONFIDENCE II NOT TO REPRODUCE OR COPY IT III NOT TO REVEAL OR PUBLISH IT IN WHOLE OR PART IV ALL RIGHTS RESERVED		051-8962	D
		REVISION	
		A.0.0	
		BRANCH	
		PAGE	36 OF 106
		SHEET	19 OF 42

MIN LINE WIDTH=0.6MM
MIN NECK WIDTH=0.2MM
MAX NECK LENGTH=75 MM

SPEAKER AMPLIFIER

APN:353S2958

80HZ +/- XXX% TURN ON TIME: 7.5MS
 TURN ON DELAY: 20MS

GAIN	VDD	GND
12DB	47K	NC
9DB	NC	47K
6DB	SHORT	NC
3DB	NC	NC
0DB	NC	SHORT

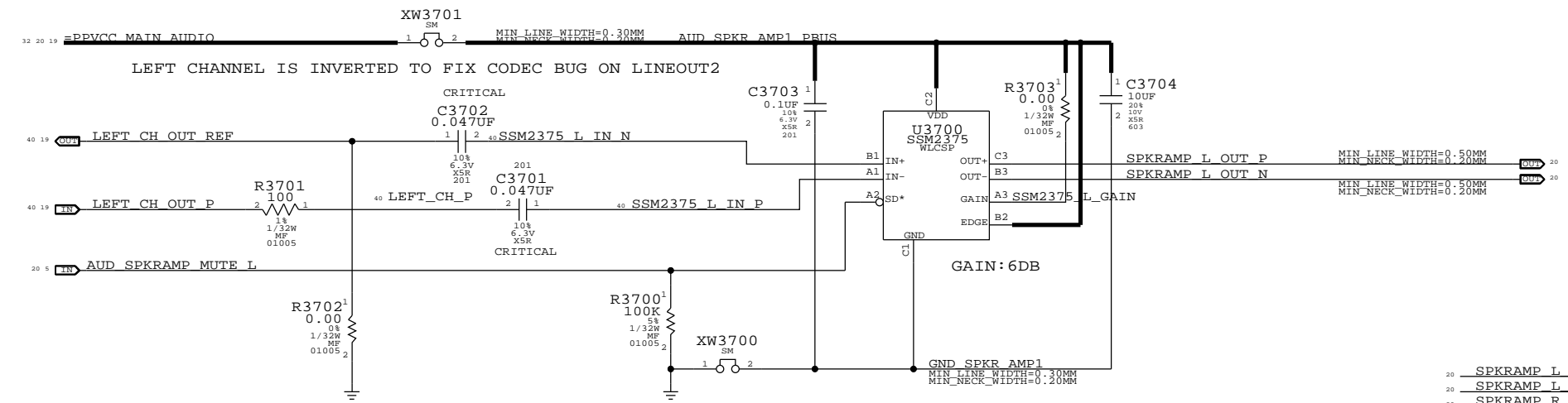

L63 LINEOUT2A IS CONNECTED TO U3700
 L63 LINEOUT2B IS CONNECTED TO U3710

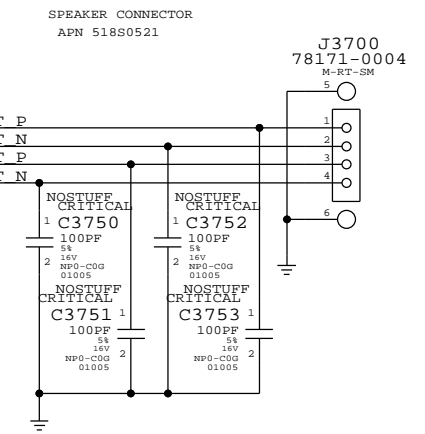
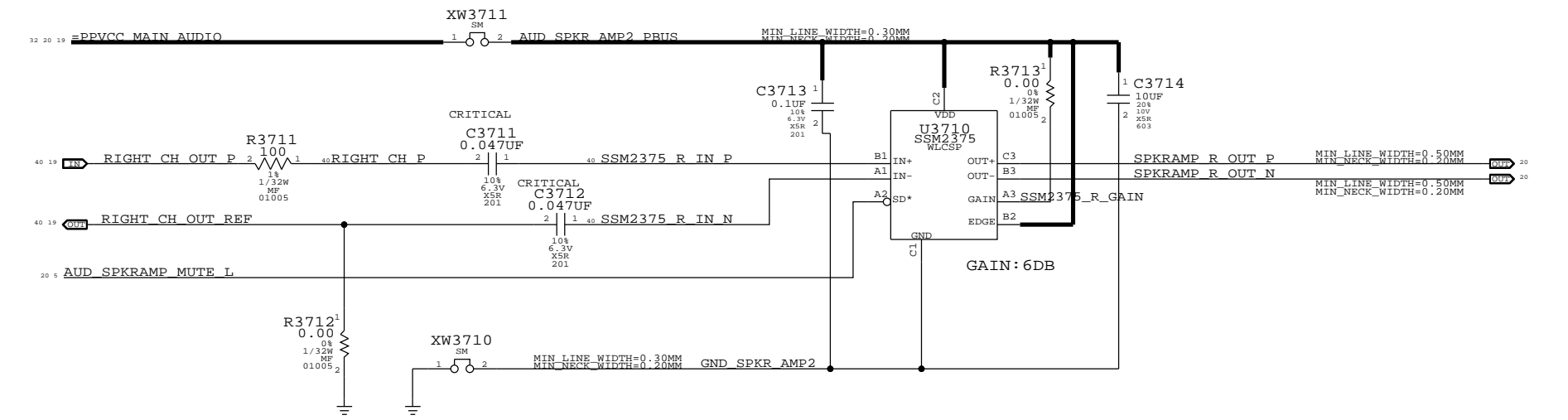

SYNC MASTER=LENG		SYNC DATE=N/A	
PAGE TITLE: AUDIO: SPEAKER AMP			
DRAWING NUMBER: 051-8962		SIZE: D	
REVISION: A.0.0		BRANCH:	
PAGE: 37 OF 106		SHEET: 20 OF 42	
NOTICE OF PROPRIETARY PROPERTY: THE INFORMATION CONTAINED HEREIN IS THE PROPRIETARY PROPERTY OF APPLE COMPUTER, INC. THE POSSESSOR AGREES TO THE FOLLOWING: I TO MAINTAIN THIS DOCUMENT IN CONFIDENCE II NOT TO REPRODUCE OR COPY IT III NOT TO REVEAL OR PUBLISH IT IN WHOLE OR PART IV ALL RIGHTS RESERVED			

HEADPHONE OUTPUT ZOBEL NETWORK

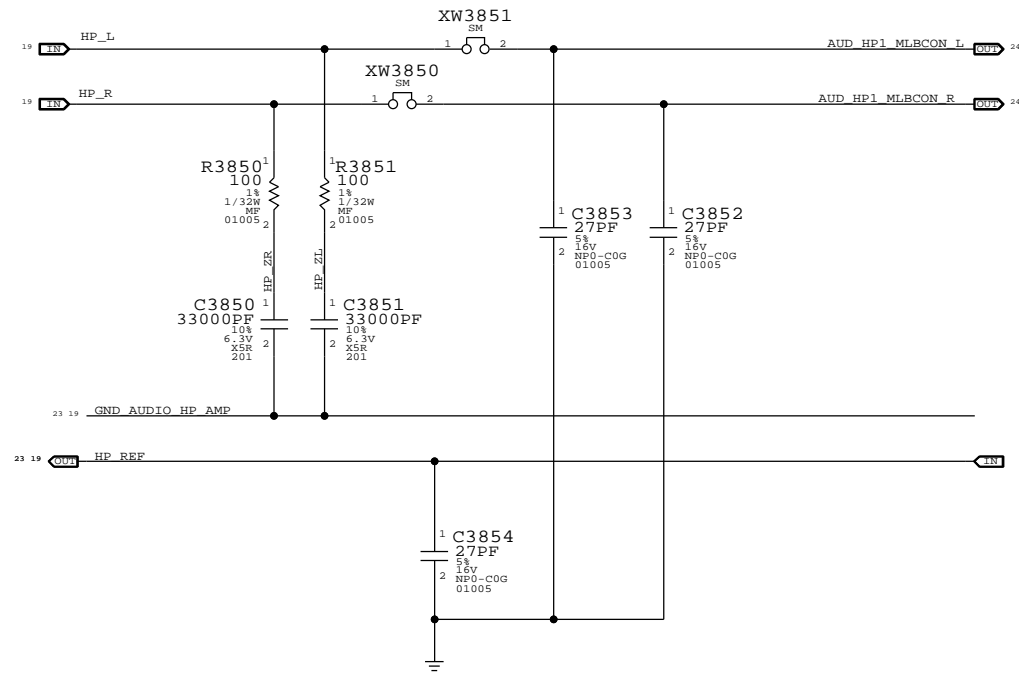

DOCK LINE OUTPUT

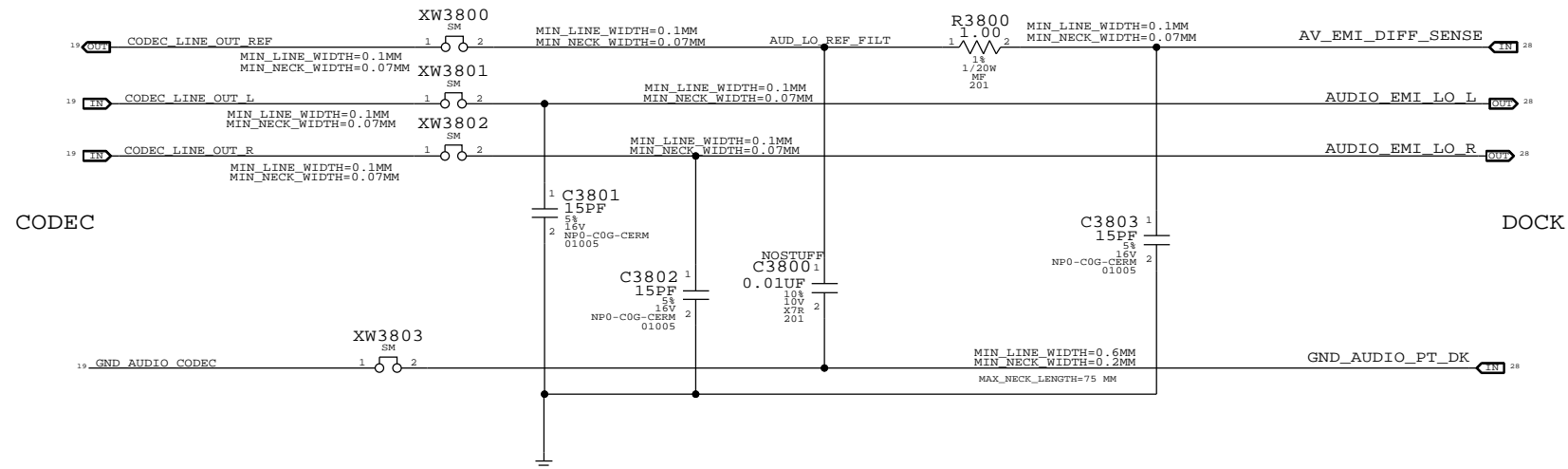

www.laptop-schematics.com

SYNC MASTER=LENG		SYNC DATE=N/A	
PAGE TITLE AUDIO: HEADPHONE OUT			
DRAWING NUMBER 051-8962		SIZE D	
REVISION A.0.0		BRANCH	
NOTICE OF PROPRIETARY PROPERTY: THE INFORMATION CONTAINED HEREIN IS THE PROPRIETARY PROPERTY OF APPLE COMPUTER, INC. THE POSSESSOR AGREES TO THE FOLLOWING: I TO MAINTAIN THIS DOCUMENT IN CONFIDENCE II NOT TO REPRODUCE OR COPY IT III NOT TO REVEAL OR PUBLISH IT IN WHOLE OR PART IV ALL RIGHTS RESERVED			
PAGE 38 OF 106		SHEET 21 OF 42	

8

7

6

5

4

3

2

1

D

D

C

C

B

B

A

A

www.laptop-schematics.com

SYNC MASTER=LENG		SYNC DATE=N/A	
PAGE TITLE AUDIO: BLANK			
 Apple Inc.	DRAWING NUMBER	051-8962	SIZE D
	REVISION	A.0.0	
NOTICE OF PROPRIETARY PROPERTY:		BRANCH	
THE INFORMATION CONTAINED HEREIN IS THE PROPRIETARY PROPERTY OF APPLE COMPUTER, INC. THE POSSESSOR AGREES TO THE FOLLOWING:		PAGE	
I TO MAINTAIN THIS DOCUMENT IN CONFIDENCE		39 OF 106	
II NOT TO REPRODUCE OR COPY IT		SHEET	
III NOT TO REVEAL OR PUBLISH IT IN WHOLE OR PART		22 OF 42	
IV ALL RIGHTS RESERVED			

8

7

6

5

4

3

2

1

EXTERNAL (HEADSET) MIC INPUT CIRCUITRY

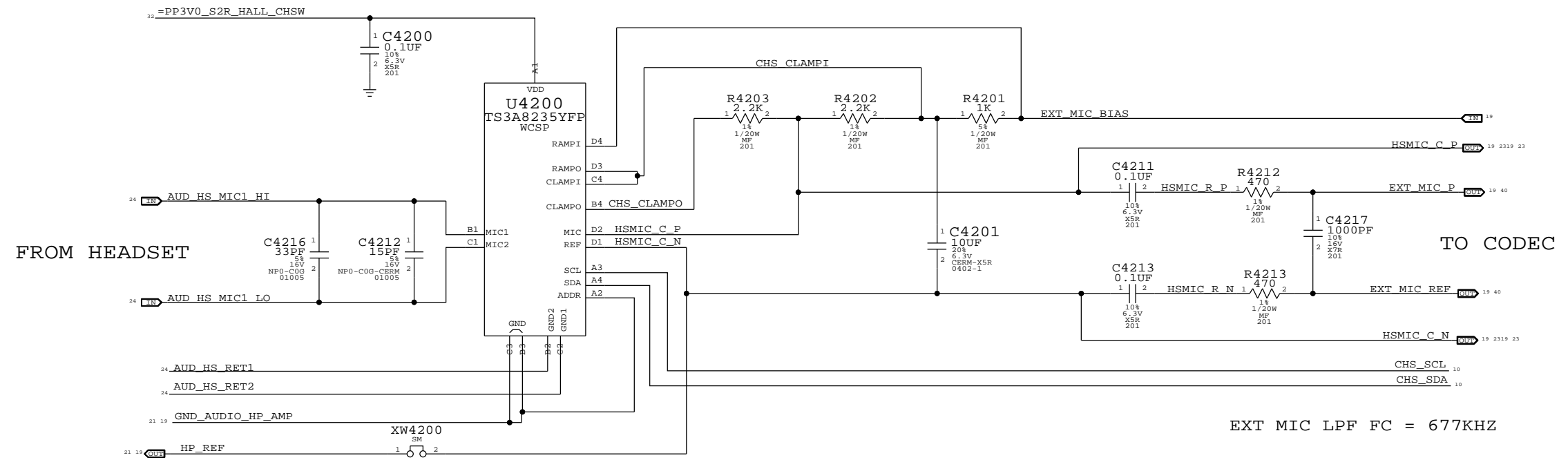

EXT MIC LPF FC = 677KHZ

www.laptop-schematics.com

SYNC MASTER=LENG		SYNC DATE=N/A	
AUDIO: DETECT/MIC BIAS			
Apple Inc.		DRAWING NUMBER	SIZE
		051-8962	D
		REVISION	
		A.0.0	
NOTICE OF PROPRIETARY PROPERTY:		BRANCH	
THE INFORMATION CONTAINED HEREIN IS THE PROPRIETARY PROPERTY OF APPLE COMPUTER, INC. THE POSSESSOR AGREES TO THE FOLLOWING:		PAGE	
I TO MAINTAIN THIS DOCUMENT IN CONFIDENCE		42 OF 106	
II NOT TO REPRODUCE OR COPY IT		SHEET	
III NOT TO REVEAL OR PUBLISH IT IN WHOLE OR PART		23 OF 42	
IV ALL RIGHTS RESERVED			

HEADPHONE JACK CONNECTION IS ON FRONT PANEL FLEX, CSA 55/PDF 29
 PLACE ALL COMPONENTS NEAR J5501

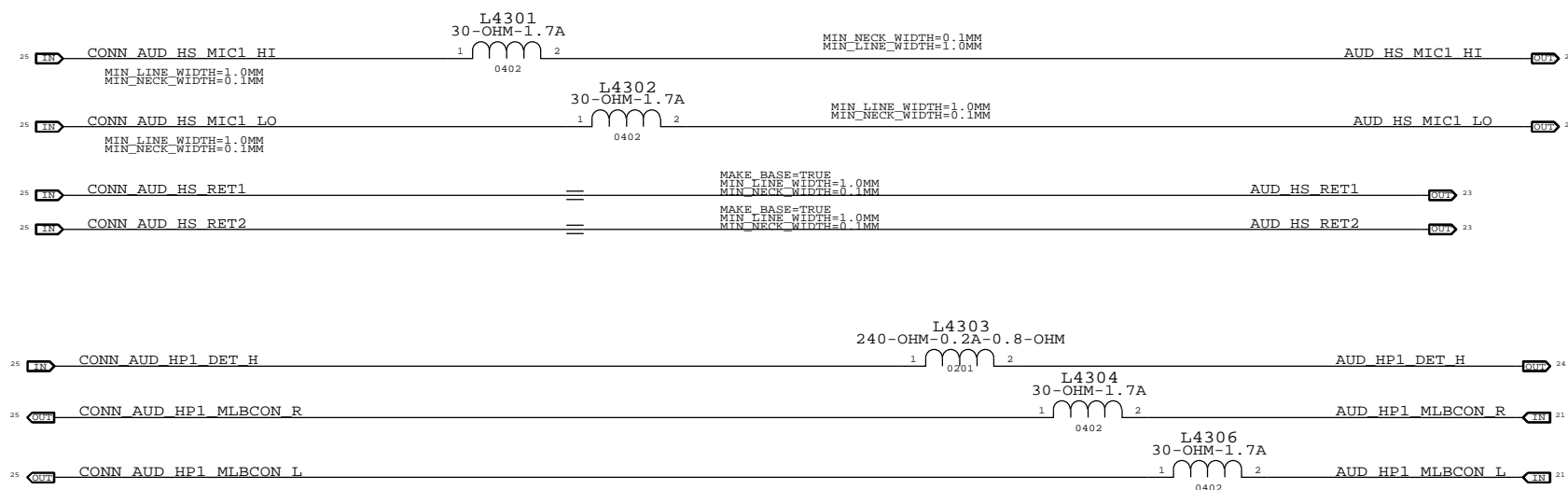

HEADSET JACK INSERTION DETECT

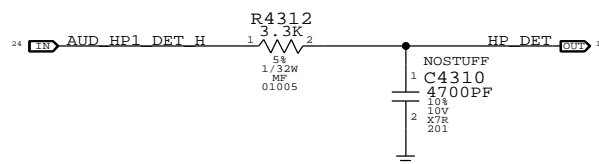

www.laptop-schematics.com

SYNC MASTER=LENG		SYNC DATE=N/A	
AUDIO: HP/MIC FILTERS			
DRAWING NUMBER		SIZE	
051-8962		D	
REVISION		BRANCH	
A.0.0			
NOTICE OF PROPRIETARY PROPERTY:			
THE INFORMATION CONTAINED HEREIN IS THE PROPRIETARY PROPERTY OF APPLE COMPUTER, INC. THE POSSESSOR AGREES TO THE FOLLOWING:			
I TO MAINTAIN THIS DOCUMENT IN CONFIDENCE			
II NOT TO REPRODUCE OR COPY IT			
III NOT TO REVEAL OR PUBLISH IT IN WHOLE OR PART			
IV ALL RIGHTS RESERVED			
PAGE		SHEET	
43 OF 106		24 OF 42	

CANADA FLEXES CONN.

APN: 518S0817

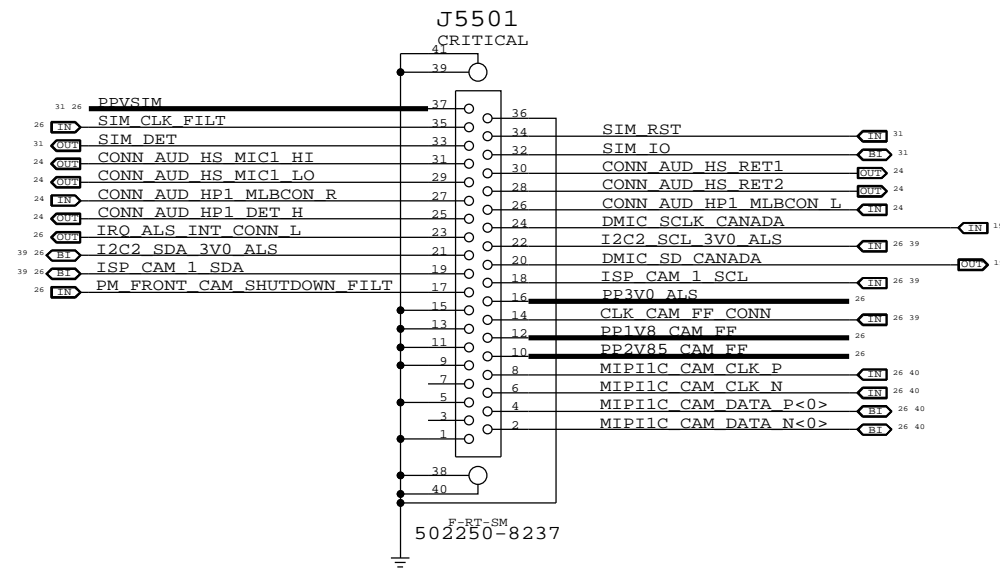

SENSOR BOARD CONN ALIASES

39	27	CLK_CAM_RF_FILT	==	CONN_CLK_CAM_RF_FILT	27	
40	27	MIP11C_CAM_DATA_N<0>	MAKE_BASE-TWIR	==	CONN_MIP11C_CAM_DATA_N<0>	27
40	27	MIP11C_CAM_DATA_P<0>	MAKE_BASE-TWIR	==	CONN_MIP11C_CAM_DATA_P<0>	27
40	27	MIP11C_CAM_CLK_N	MAKE_BASE-TWIR	==	CONN_MIP11C_CAM_CLK_N	27
40	27	MIP11C_CAM_CLK_P	MAKE_BASE-TWIR	==	CONN_MIP11C_CAM_CLK_P	27
7	27	PM_REAR_CAM_SHUTDOWN	MAKE_BASE-TWIR	==	CONN_PM_REAR_CAM_SHUTDOWN	27
27	27	PP1V8_SENSOR_FILT	MAKE_BASE-TWIR	==	CONN_PP1V8_SENSOR_FILT	27
27	27	PP2V85_CAM_REAR	MAKE_BASE-TWIR	==	CONN_PP2V85_CAM_REAR	27
19	27	DMIC_SD_SENSOR	MAKE_BASE-TWIR	==	CONN_DMIC_SD_SENSOR	27
19	27	DMIC_SCLK_SENSOR	MAKE_BASE-TWIR	==	CONN_DMIC_SCLK_SENSOR	27
19	27	ISP_AP_0_SCL	MAKE_BASE-TWIR	==	CONN_ISP_AP_0_SCL	27
19	27	ISP_AP_0_SDA	MAKE_BASE-TWIR	==	CONN_ISP_AP_0_SDA	27
19	27	I2C2_SCL_3V0	MAKE_BASE-TWIR	==	CONN_I2C2_SCL_3V0	27
19	27	I2C2_SDA_3V0	MAKE_BASE-TWIR	==	CONN_I2C2_SDA_3V0	27
5	27	IRO_ACCEL_INT1_L	MAKE_BASE-TWIR	==	CONN_IRO_ACCEL_INT1_L	27
5	27	IRO_ACCEL_INT2_L	MAKE_BASE-TWIR	==	CONN_IRO_ACCEL_INT2_L	27
5	27	IRO_GYRO_INT1	MAKE_BASE-TWIR	==	CONN_IRO_GYRO_INT1	27
5	27	IRO_GYRO_INT2	MAKE_BASE-TWIR	==	CONN_IRO_GYRO_INT2	27
19	27	I2C1_SCL_1V8	MAKE_BASE-TWIR	==	CONN_I2C1_SCL_1V8	27
19	27	I2C1_SDA_1V8	MAKE_BASE-TWIR	==	CONN_I2C1_SDA_1V8	27
19	27	IRO_HALL	MAKE_BASE-TWIR	==	CONN_IRO_HALL	27
19	27	IRO_PROX_INT_L	MAKE_BASE-TWIR	==	CONN_IRO_PROX_INT_L	27
27	27	PP3V0_S2R_HALL_FILT	MAKE_BASE-TWIR	==	CONN_PP3V0_S2R_HALL	27
15	27	ONOFF_L	MAKE_BASE-TWIR	==	CONN_ONOFF_FTR_L	27
15	27	SRL_L	MAKE_BASE-TWIR	==	CONN_SRL_FTR_L	27
15	27	AUD_VOL_UP_L	MAKE_BASE-TWIR	==	CONN_AUD_VOL_UP_FTR_L	27
15	27	AUD_VOL_DOWN_L	MAKE_BASE-TWIR	==	CONN_AUD_VOL_DOWN_FTR_L	27
27	27	PP3V0_OPTICAL_SENS	MAKE_BASE-TWIR	==	CONN_PP3V0_OPTICAL_SENS	27

www.laptop-schematics.com

SYNC MASTER=MARK B.		SYNC DATE=N/A	
CONNECTOR: CANADA FLEX CONN,SENSOR PANEL ALIASES			
Apple Inc.	DRAWING NUMBER	051-8962	SIZE
	REVISION	A.0.0	D
NOTICE OF PROPRIETARY PROPERTY:		BRANCH	
THE INFORMATION CONTAINED HEREIN IS THE PROPRIETARY PROPERTY OF APPLE COMPUTER, INC. THE POSSESSOR AGREES TO THE FOLLOWING:		PAGE	
I TO MAINTAIN THIS DOCUMENT IN CONFIDENCE		54 OF 106	
II NOT TO REPRODUCE OR COPY IT		SHEET	
III NOT TO REVEAL OR PUBLISH IT IN WHOLE OR PART		25 OF 42	
IV ALL RIGHTS RESERVED			

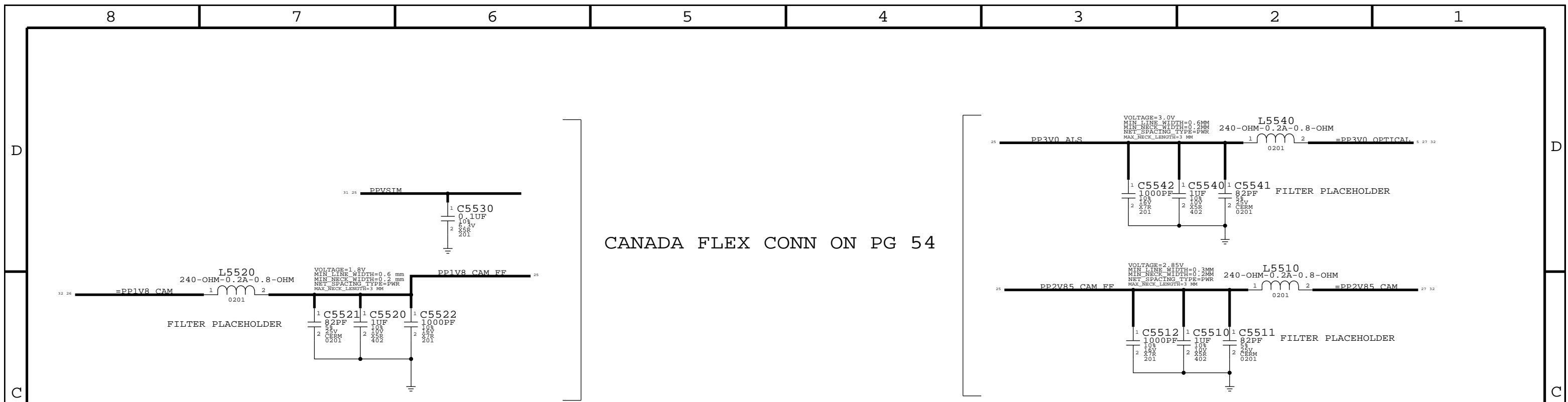

www.laptop-schematics.com

CANADA FLEX SIGNAL FILTERS

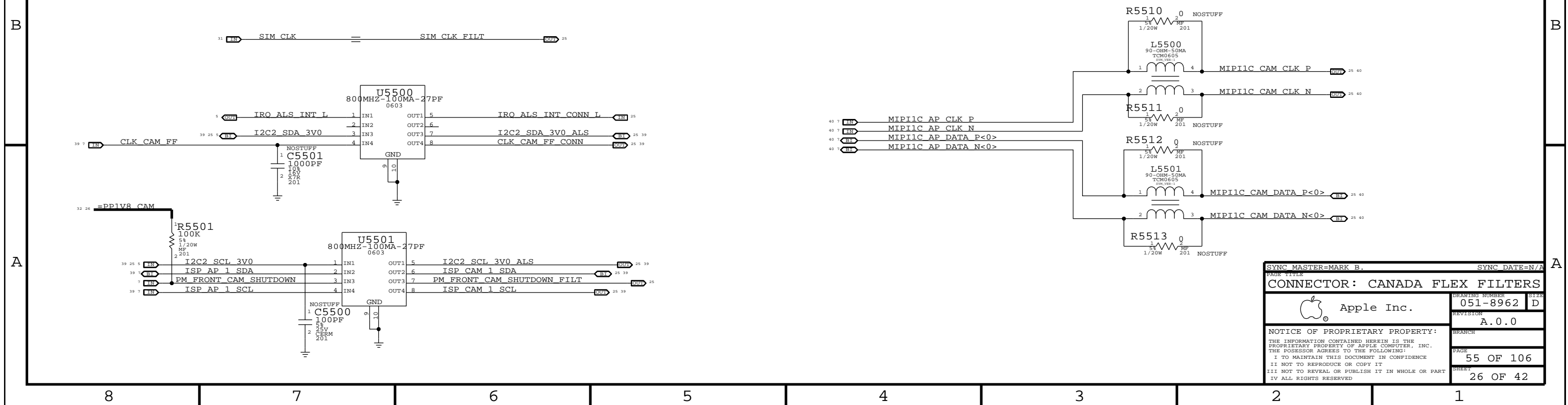

PAGE TITLE		SYNC DATE=N/A	
CONNECTOR: CANADA FLEX FILTERS			
Apple Inc.	DRAWING NUMBER	051-8962	SIZE D
	REVISION	A.0.0	
NOTICE OF PROPRIETARY PROPERTY:			
THE INFORMATION CONTAINED HEREIN IS THE PROPRIETARY PROPERTY OF APPLE COMPUTER, INC. THE POSSESSOR AGREES TO THE FOLLOWING:			
I TO MAINTAIN THIS DOCUMENT IN CONFIDENCE			
II NOT TO REPRODUCE OR COPY IT			
III NOT TO REVEAL OR PUBLISH IT IN WHOLE OR PART			
IV ALL RIGHTS RESERVED			
BRANCH		PAGE	55 OF 106
SHEET		26 OF 42	

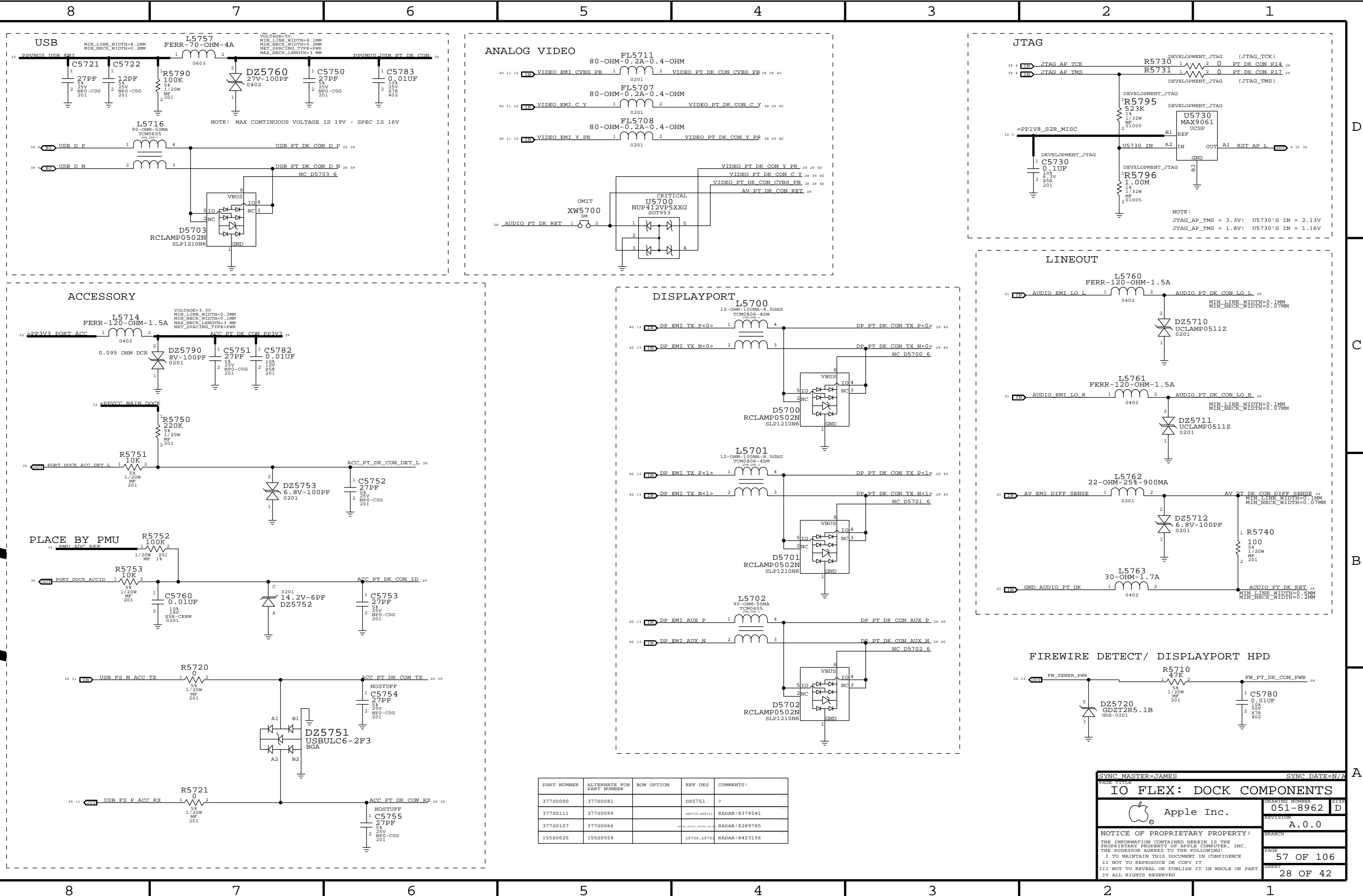

PART NUMBER	ALTERNATE FOR PART NUMBER	BOM OPTION	REF DES	COMMENTS
377S0090	377S0081		DZ5751	?
377S0111	377S0099		025710, 025711	RADAR:8379541
377S0107	377S0066		025710, 025711, 025712	RADAR:8289785
155S0625	155S0559		L5700, L5701	RADAR:8423156

SYNC MASTER=JAMES SYNC DATE=N/A

IO FLEX: DOCK COMPONENTS

Apple Inc.

DRAWING NUMBER: 051-8962 SIZE: D

REVISION: A.0.0

NOTICE OF PROPRIETARY PROPERTY:
 THE INFORMATION CONTAINED HEREIN IS THE PROPRIETARY PROPERTY OF APPLE COMPUTER, INC. THE POSSESSOR AGREES TO THE FOLLOWING:
 I TO MAINTAIN THIS DOCUMENT IN CONFIDENCE
 II NOT TO REPRODUCE OR COPY IT
 III NOT TO REVEAL OR PUBLISH IT IN WHOLE OR PART
 IV ALL RIGHTS RESERVED

PAGE: 57 OF 106
 SHEET: 28 OF 42

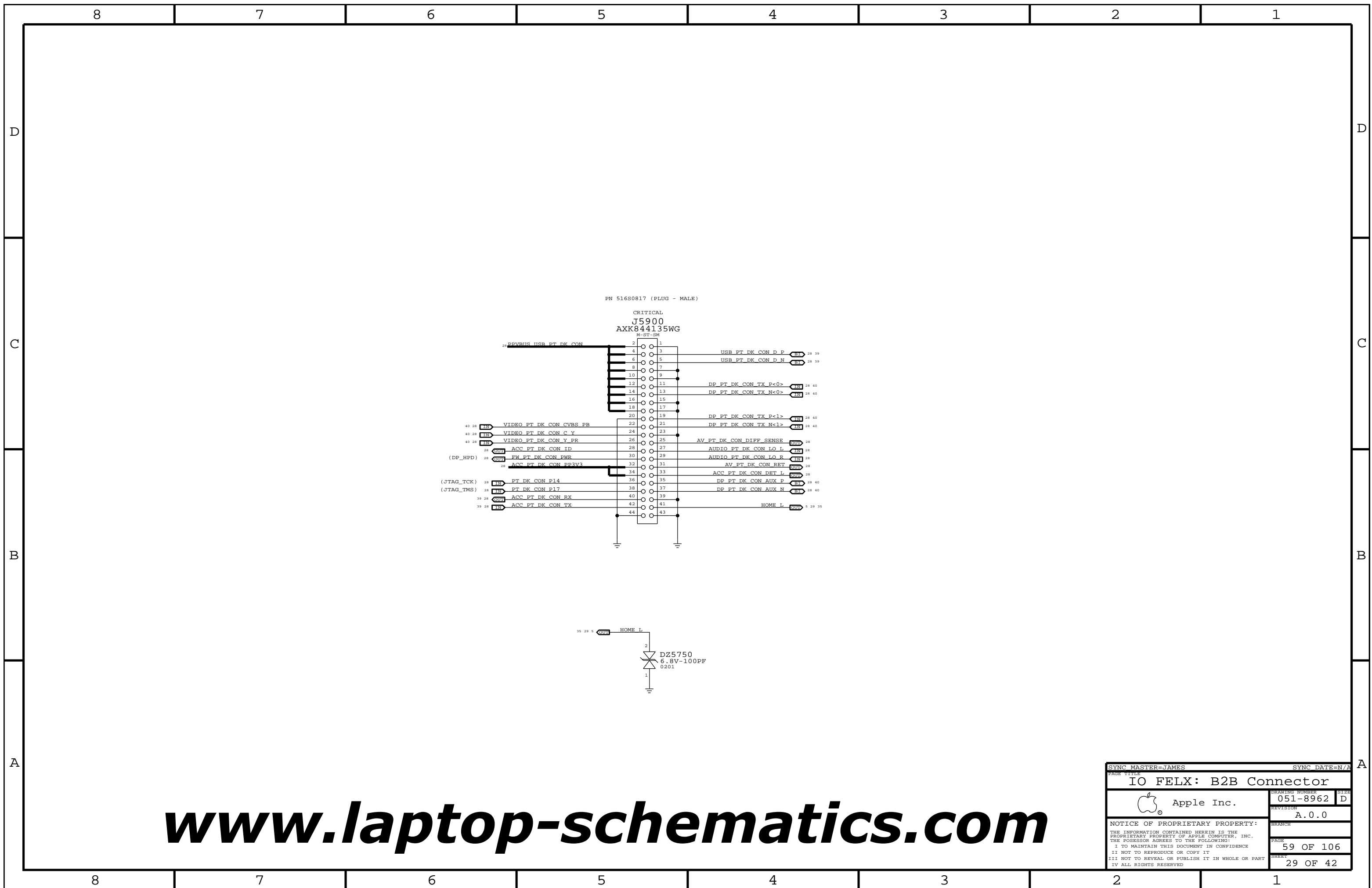

www.laptop-schematics.com

SYNC MASTER=JAMES		SYNC DATE=N/A	
PAGE TITLE IO FELX: B2B Connector			
Apple Inc.	DRAWING NUMBER 051-8962	SIZE D	
	REVISION A.0.0	BRANCH	
NOTICE OF PROPRIETARY PROPERTY: THE INFORMATION CONTAINED HEREIN IS THE PROPRIETARY PROPERTY OF APPLE COMPUTER, INC. THE POSSESSOR AGREES TO THE FOLLOWING: I TO MAINTAIN THIS DOCUMENT IN CONFIDENCE II NOT TO REPRODUCE OR COPY IT III NOT TO REVEAL OR PUBLISH IT IN WHOLE OR PART IV ALL RIGHTS RESERVED			PAGE 59 OF 106 SHEET 29 OF 42

X23 WIFI/BT CONNECTOR

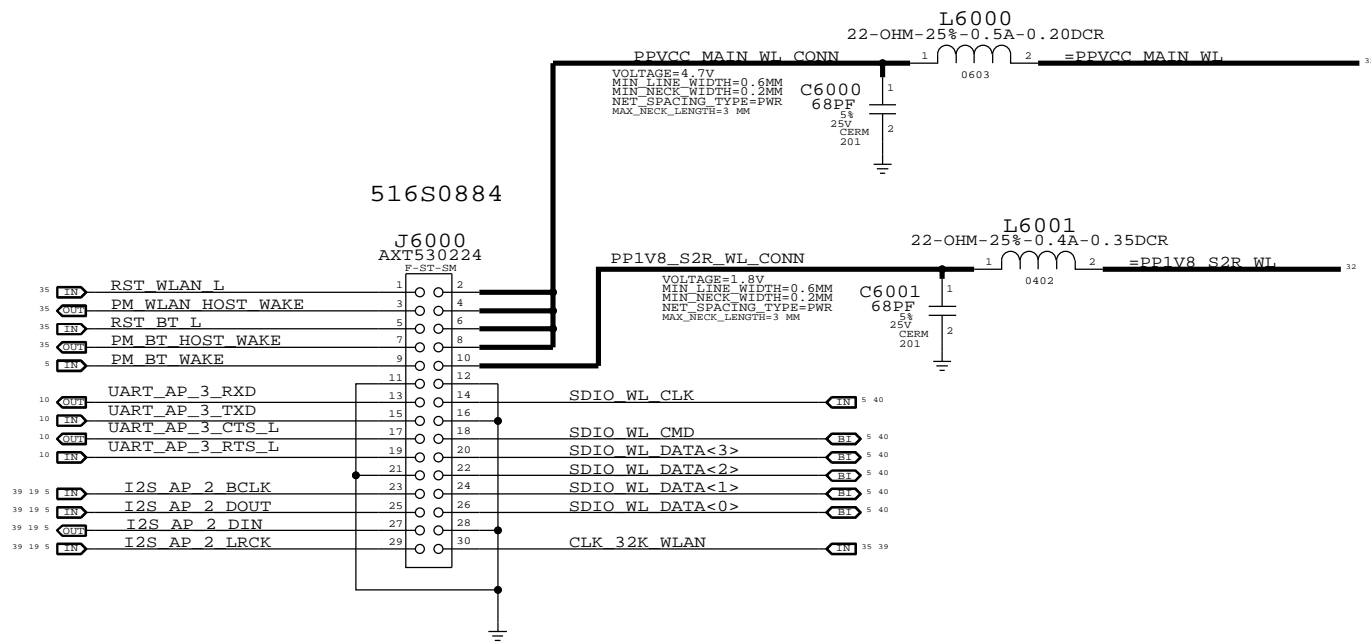

www.laptop-schematics.com

SYNC MASTER=MIKE		SYNC DATE=N/A	
CONNECTOR: X23 WIFI/BT			
DRAWING NUMBER		SIZE	
051-8962		D	
REVISION		BRANCH	
A.0.0			
NOTICE OF PROPRIETARY PROPERTY:			
THE INFORMATION CONTAINED HEREIN IS THE PROPRIETARY PROPERTY OF APPLE COMPUTER, INC. THE POSSESSOR AGREES TO THE FOLLOWING:			
I TO MAINTAIN THIS DOCUMENT IN CONFIDENCE			
II NOT TO REPRODUCE OR COPY IT			
III NOT TO REVEAL OR PUBLISH IT IN WHOLE OR PART			
IV ALL RIGHTS RESERVED			
PAGE		SHEET	
60 OF 106		30 OF 42	

X24 CELLULAR/GPS CONNECTOR



www.laptop-schematics.com

SYNC MASTER=MIKE		SYNC DATE=N/A	
CONNECTOR: X24 CELLULAR/GPS			
Apple Inc.		DRAWING NUMBER	SIZE
		051-8962	D
		REVISION	
		A.0.0	
NOTICE OF PROPRIETARY PROPERTY:			
THE INFORMATION CONTAINED HEREIN IS THE PROPRIETARY PROPERTY OF APPLE COMPUTER, INC. THE POSSESSOR AGREES TO THE FOLLOWING:			
I TO MAINTAIN THIS DOCUMENT IN CONFIDENCE			
II NOT TO REPRODUCE OR COPY IT			
III NOT TO REVEAL OR PUBLISH IT IN WHOLE OR PART			
IV ALL RIGHTS RESERVED			
		PAGE	
		61 OF 106	
		SHEET	
		31 OF 42	

POWER CONN / ALIAS

LDO RAILS

PROGRAMMABLE ON/OFF

BUCK RAILS

CHARGER MAIN

BATTERY

USB POWER INPUT

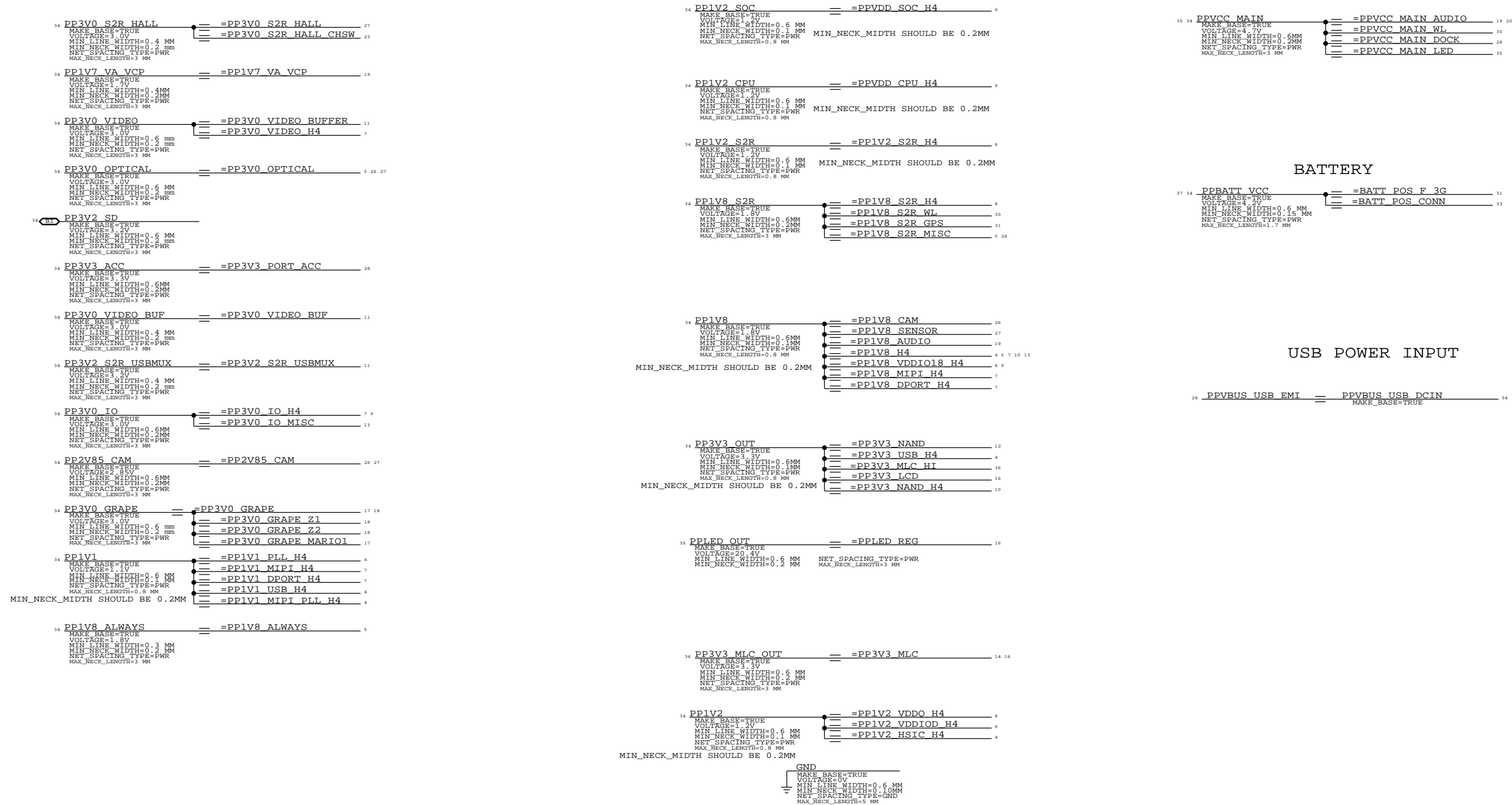

www.laptop-schematics.com

SYNC MASTER=YOSH		SYNC DATE=N/A	
PAGE TITLE: POWER: ALIASES			
Apple Inc.	DRAWING NUMBER	051-8962	SIZE D
	REVISION	A.0.0	
NOTICE OF PROPRIETARY PROPERTY:		BRANCH	
THE INFORMATION CONTAINED HEREIN IS THE PROPRIETARY PROPERTY OF APPLE COMPUTER, INC. THE POSSESSOR AGREES TO THE FOLLOWING:		PAGE	
I TO MAINTAIN THIS DOCUMENT IN CONFIDENCE		73 OF 106	
II NOT TO REPRODUCE OR COPY IT		SHEET	
III NOT TO REVEAL OR PUBLISH IT IN WHOLE OR PART		32 OF 42	
IV ALL RIGHTS RESERVED			

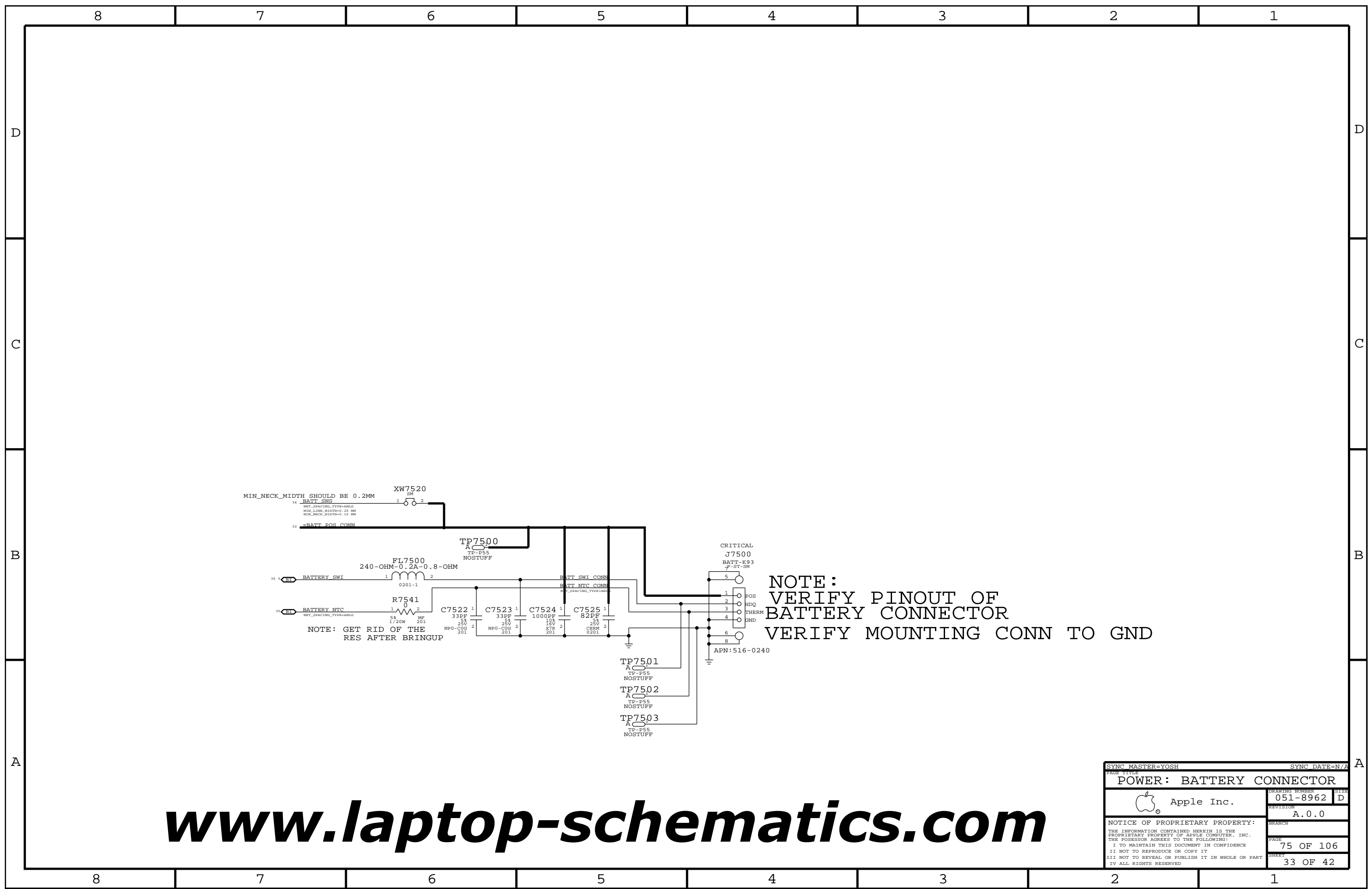

NOTE:
 VERIFY PINOUT OF
 BATTERY CONNECTOR
 VERIFY MOUNTING CONN TO GND

www.laptop-schematics.com

SYNC MASTER=YOSH		SYNC DATE=N/A	
POWER: BATTERY CONNECTOR			
DRAWING NUMBER		SIZE	
051-8962		D	
REVISION		BRANCH	
A.0.0			
NOTICE OF PROPRIETARY PROPERTY:			
THE INFORMATION CONTAINED HEREIN IS THE PROPRIETARY PROPERTY OF APPLE COMPUTER, INC. THE POSSESSOR AGREES TO THE FOLLOWING:			
I TO MAINTAIN THIS DOCUMENT IN CONFIDENCE			
II NOT TO REPRODUCE OR COPY IT			
III NOT TO REVEAL OR PUBLISH IT IN WHOLE OR PART			
IV ALL RIGHTS RESERVED			
PAGE		SHEET	
75 OF 106		33 OF 42	

PART#	QTY	DESCRIPTION	REFERENCE DESIGNATOR(S)	CRITICAL	BOM OPTION
34380542	1	IC, PMU, ALISON, D1946A2, OTPXX, UFBGA292	U8100	CRITICAL	

PART NUMBER	ALTERNATE FOR PART NUMBER	BOM OPTION	REF DES	COMMENTS:
19780392	19780299		Y8138	ALT FOUNDRY

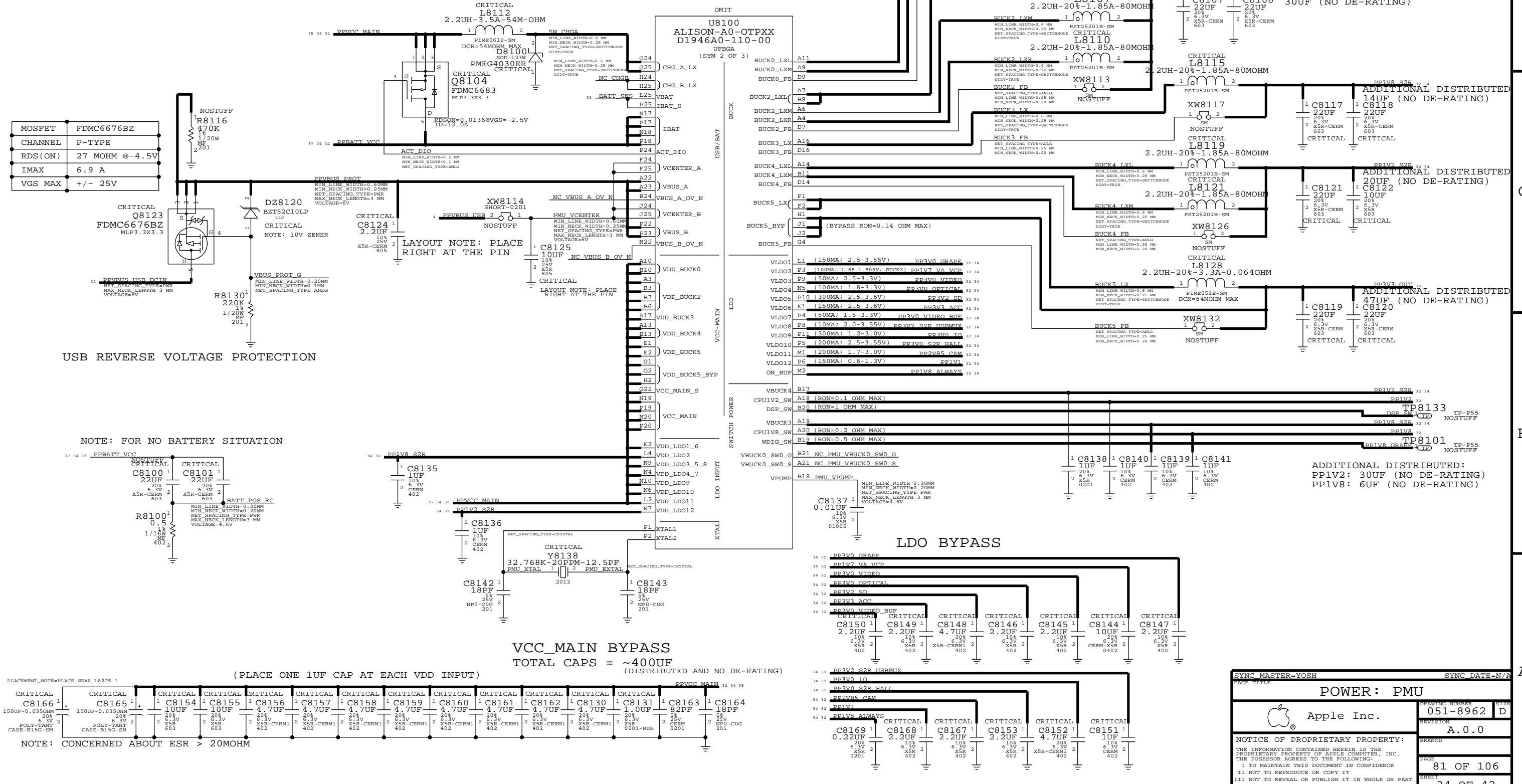

MOSFET	FDMC6676BZ
CHANNEL	P-TYPE
RDS(ON)	27 MOHM @-4.5V
IMAX	6.9 A
VGS MAX	+/- 25V

USB REVERSE VOLTAGE PROTECTION

NOTE: FOR NO BATTERY SITUATION

VCC_MAIN BYPASS
TOTAL CAPS = ~400UF
(DISTRIBUTED AND NO DE-RATING)

PLACEMENT NOTE=PLACE NEAR L8225.1 (PLACE ONE 1UF CAP AT EACH VDD INPUT)

CRITICAL C8166 150UF-0.035OHM	CRITICAL C8165 150UF-0.035OHM	CRITICAL C8154 10UF	CRITICAL C8155 10UF	CRITICAL C8156 4.7UF	CRITICAL C8157 4.7UF	CRITICAL C8158 4.7UF	CRITICAL C8159 4.7UF	CRITICAL C8160 4.7UF	CRITICAL C8161 4.7UF	CRITICAL C8162 4.7UF	CRITICAL C8130 4.7UF	CRITICAL C8131 1.0UF	CRITICAL C8163 82PF	CRITICAL C8164 18PF
-------------------------------	-------------------------------	---------------------	---------------------	----------------------	----------------------	----------------------	----------------------	----------------------	----------------------	----------------------	----------------------	----------------------	---------------------	---------------------

NOTE: CONCERNED ABOUT ESR > 20MOHM

SYNC MASTER=YOSH SYNC DATE=N/A

POWER: PMU

Apple Inc.

Drawing Number: 051-8962

Revision: A.0.0

Page: 81 OF 106

Sheet: 34 OF 42

NOTICE OF PROPRIETARY PROPERTY: THE INFORMATION CONTAINED HEREIN IS THE PROPRIETARY PROPERTY OF APPLE COMPUTER, INC. THE POSSESSOR AGREES TO THE FOLLOWING: I TO MAINTAIN THIS DOCUMENT IN CONFIDENCE II NOT TO REPRODUCE OR COPY IT III NOT TO REVEAL OR PUBLISH IT IN WHOLE OR PART IV ALL RIGHTS RESERVED

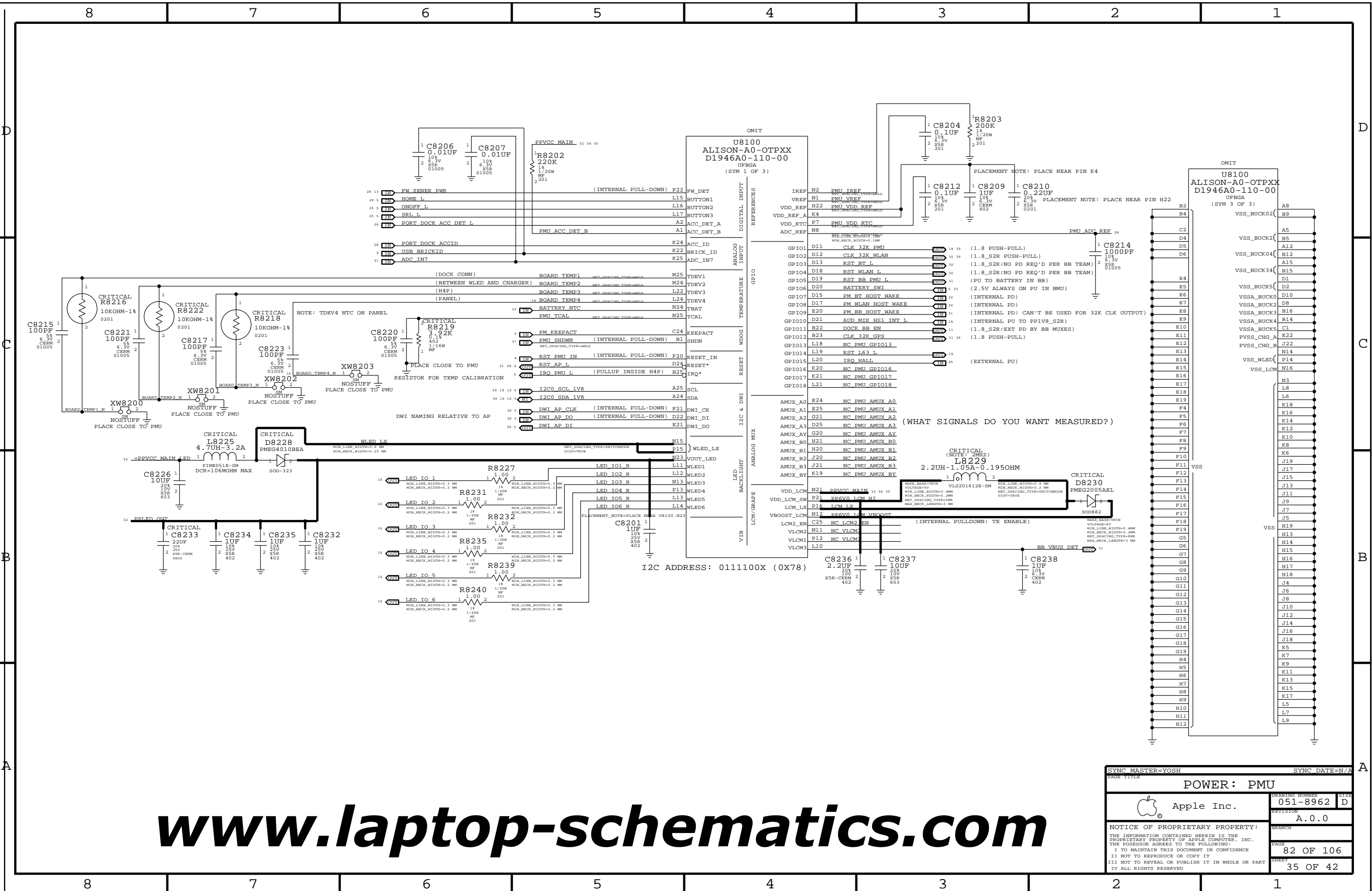

SYNC MASTER=YOSH		SYNC DATE=N/A	
PAGE TITLE			
POWER: PMU		DRAWING NUMBER	SIZE
Apple Inc.		051-8962	D
NOTICE OF PROPRIETARY PROPERTY:		REVISION	
THE INFORMATION CONTAINED HEREIN IS THE PROPRIETARY PROPERTY OF APPLE COMPUTER, INC. THE POSSESSOR AGREES TO THE FOLLOWING:		A.0.0	
I TO MAINTAIN THIS DOCUMENT IN CONFIDENCE		BRANCH	
II NOT TO REPRODUCE OR COPY IT		PAGE	82 OF 106
III NOT TO REVEAL OR PUBLISH IT IN WHOLE OR PART		SHEET	35 OF 42
IV ALL RIGHTS RESERVED			

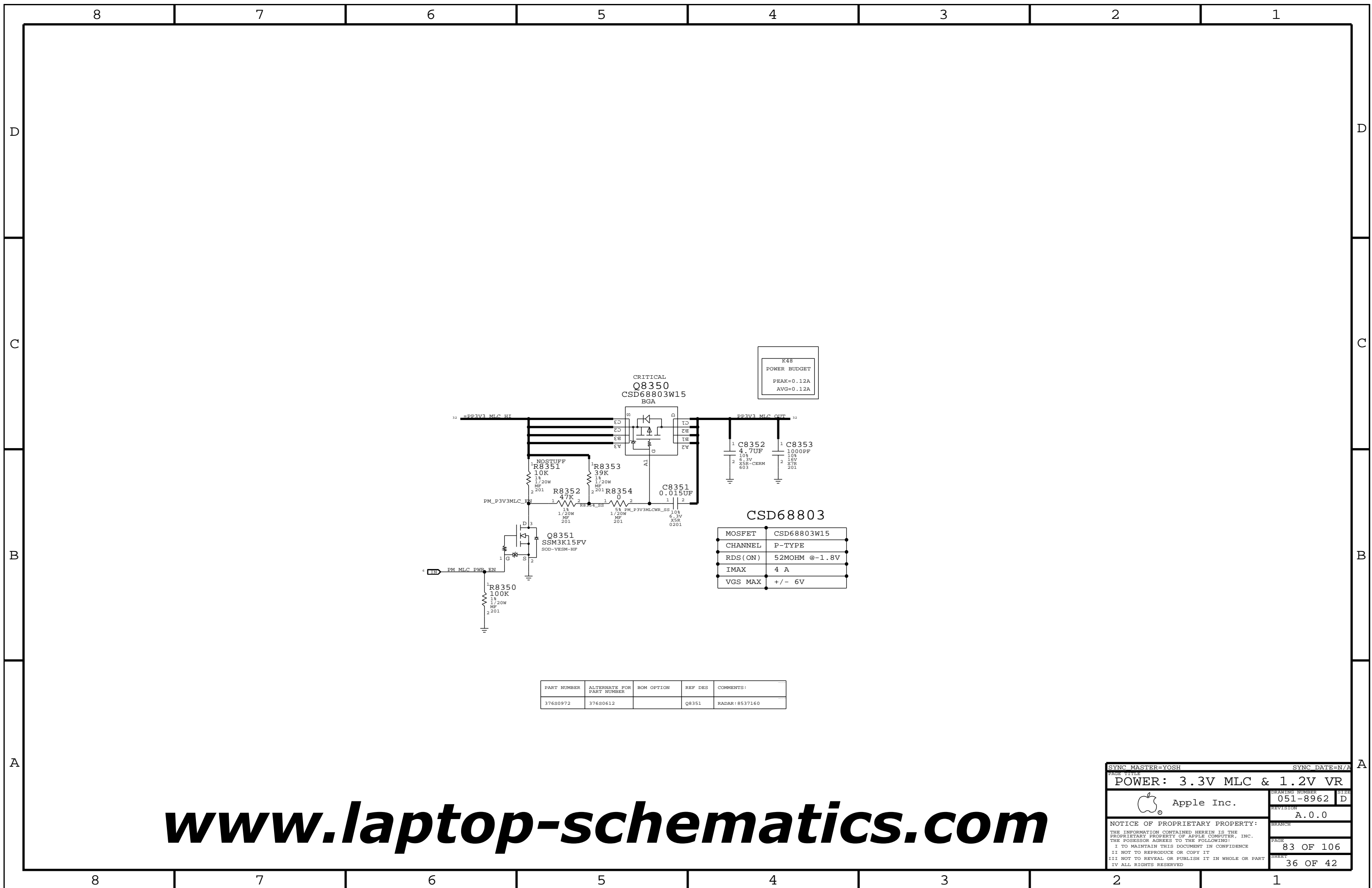

www.laptop-schematics.com

SYNC MASTER=YOSH		SYNC DATE=N/A	
PAGE TITLE POWER: 3.3V MLC & 1.2V VR			
Apple Inc.	DRAWING NUMBER	051-8962	SIZE D
	REVISION	A.0.0	BRANCH
NOTICE OF PROPRIETARY PROPERTY: THE INFORMATION CONTAINED HEREIN IS THE PROPRIETARY PROPERTY OF APPLE COMPUTER, INC. THE POSSESSOR AGREES TO THE FOLLOWING: I TO MAINTAIN THIS DOCUMENT IN CONFIDENCE II NOT TO REPRODUCE OR COPY IT III NOT TO REVEAL OR PUBLISH IT IN WHOLE OR PART IV ALL RIGHTS RESERVED		PAGE	83 OF 106
		SHEET	36 OF 42

DEBUG RESET ACCESS

PLACE OUTSIDE OF CAN?

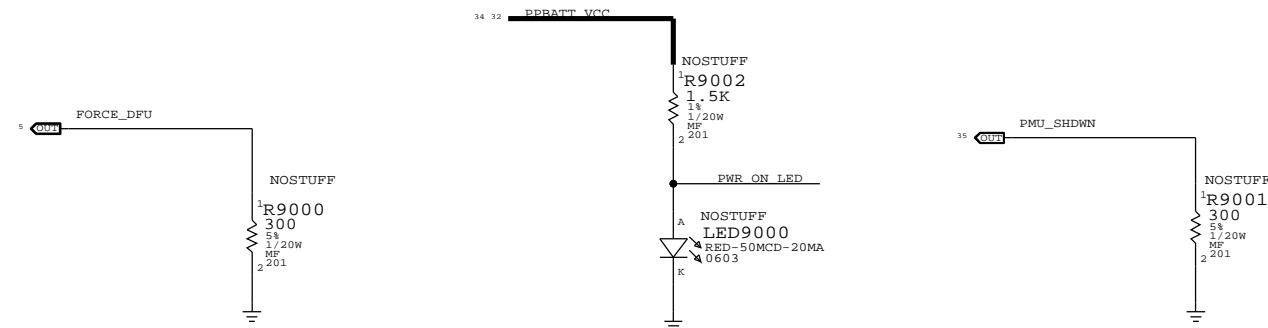

LEFT AND RIGHT MOUNTING TABS

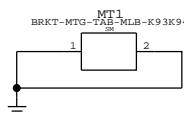

www.laptop-schematics.com

SYNC MASTER=MIKE		SYNC DATE=N/A			
PAGE TITLE DEBUG AND MISC					
 Apple Inc.	DRAWING NUMBER	051-8962	SIZE D		
	REVISION	A.0.0	BRANCH		
NOTICE OF PROPRIETARY PROPERTY: THE INFORMATION CONTAINED HEREIN IS THE PROPRIETARY PROPERTY OF APPLE COMPUTER, INC. THE POSSESSOR AGREES TO THE FOLLOWING: I TO MAINTAIN THIS DOCUMENT IN CONFIDENCE II NOT TO REPRODUCE OR COPY IT III NOT TO REVEAL OR PUBLISH IT IN WHOLE OR PART IV ALL RIGHTS RESERVED		PAGE	90 OF 106		
		SHEET	37 OF 42		
		THE INFORMATION CONTAINED HEREIN IS THE PROPRIETARY PROPERTY OF APPLE COMPUTER, INC. THE POSSESSOR AGREES TO THE FOLLOWING: I TO MAINTAIN THIS DOCUMENT IN CONFIDENCE II NOT TO REPRODUCE OR COPY IT III NOT TO REVEAL OR PUBLISH IT IN WHOLE OR PART IV ALL RIGHTS RESERVED			

8 7 6 5 4 3 2 1

D
C
B
A

D
C
B
A

PLATED THROUGH HOLES

DRILL SIZE: 1.1MM X 0.4MM
PLATING SIZE: 1.4MM X 0.7MM

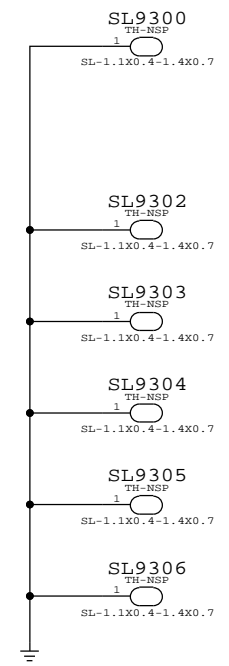

www.laptop-schematics.com

SYNC MASTER=MIKE		SYNC DATE=N/A	
FCT/ICT TEST/BRACKETS			
Apple Inc.	DRAWING NUMBER	051-8962	SIZE D
	REVISION	A.0.0	BRANCH
NOTICE OF PROPRIETARY PROPERTY: THE INFORMATION CONTAINED HEREIN IS THE PROPRIETARY PROPERTY OF APPLE COMPUTER, INC. THE POSSESSOR AGREES TO THE FOLLOWING: I TO MAINTAIN THIS DOCUMENT IN CONFIDENCE II NOT TO REPRODUCE OR COPY IT III NOT TO REVEAL OR PUBLISH IT IN WHOLE OR PART IV ALL RIGHTS RESERVED			PAGE 93 OF 106
			SHEET 38 OF 42

8 7 6 5 4 3 2 1

Clock Signal Constraints

NET_PHYSICAL_TYPE	AREA_TYPE	PHYSICAL_RULE_SET
CLK_50S	*	50_OHM_SE

NET_SPACING_TYPE1	NET_SPACING_TYPE2	AREA_TYPE	SPACING_RULE_SET
CLK	*	*	5:1_SPACING

ELECTRICAL_CONSTRAINT_SET	NET_TYPE		
	PHYSICAL	SPACING	
HE0	CLK_50S	CLK	CLK 32K PMU 18 35
HE1	CLK_50S	CLK	CLK 32K WLAN 30 35
HE2	CLK_50S	CLK	CLK 32K GPS 31 35
HE3	CLK_50S	CLK	CLK CAM FF 7 26
HE4	CLK_50S	CLK	CLK CAM FF FILT 7 26
HE5	CLK_50S	CLK	CLK CAM FF CONN 25 26
HE6	CLK_50S	CLK	CLK CAM RF 7 27
HE7	CLK_50S	CLK	CLK CAM RF FILT 25 27
HE8	CLK_50S	CLK	I2S AP 0 MCK 5
HE9	CLK_50S	CLK	I2S AP 0 MCK R 5 19
HE10	CLK_50S	CLK	CLK CAM FF R 7
HE11	CLK_50S	CLK	CLK CAM RF R 7

NAND

NET_PHYSICAL_TYPE	AREA_TYPE	PHYSICAL_RULE_SET
NAND_50S	*	50_OHM_SE

NET_SPACING_TYPE1	NET_SPACING_TYPE2	AREA_TYPE	SPACING_RULE_SET
NAND	*	*	2:1_SPACING

ELECTRICAL_CONSTRAINT_SET	NET_TYPE		
	PHYSICAL	SPACING	
HE0	NAND_50S	NAND	F0AD<7...0> 6 12
HE1	NAND_50S	NAND	F0CE0 L 6 12
HE2	NAND_50S	NAND	F0CE1 L 6 12
HE3	NAND_50S	NAND	F0CE2 L 6 12
HE4	NAND_50S	NAND	F0CE3 L 6 12
HE5	NAND_50S	NAND	F0CE4 L 6 12
HE6	NAND_50S	NAND	F0CE5 L 6 12
HE7	NAND_50S	NAND	F0CE6 L 6 12
HE8	NAND_50S	NAND	F0CE7 L 6 12
HE9	NAND_50S	NAND	F0CLE 6 12
HE10	NAND_50S	NAND	F0ALE 6 12
HE11	NAND_50S	NAND	FORE L 6 12
HE12	NAND_50S	NAND	F0WE L 6 12
HE13	NAND_50S	NAND	F0WP L 6 12
HE14	NAND_50S	NAND	F1AD<7...0> 6 12
HE15	NAND_50S	NAND	F1CE0 L 6 12
HE16	NAND_50S	NAND	F1CE1 L 6 12
HE17	NAND_50S	NAND	F1CE2 L 6 12
HE18	NAND_50S	NAND	F1CE3 L 6 12
HE19	NAND_50S	NAND	F1CE4 L 6 12
HE20	NAND_50S	NAND	F1CE5 L 6 12
HE21	NAND_50S	NAND	F1CE6 L 6 12
HE22	NAND_50S	NAND	F1CE7 L 6 12
HE23	NAND_50S	NAND	F1CLE 6 12
HE24	NAND_50S	NAND	F1ALE 6 12
HE25	NAND_50S	NAND	F1RE L 6 12
HE26	NAND_50S	NAND	F1WE L 6 12
HE27	NAND_50S	NAND	F1WP L 6 12
HE28	NAND_50S	NAND	F2AD<7...0>
HE29	NAND_50S	NAND	F2CE0 L
HE30	NAND_50S	NAND	F2CE1 L
HE31	NAND_50S	NAND	F2CE2 L
HE32	NAND_50S	NAND	F2CE3 L
HE33	NAND_50S	NAND	F2CLE
HE34	NAND_50S	NAND	F2ALE
HE35	NAND_50S	NAND	F2RE L
HE36	NAND_50S	NAND	F2WE L
HE37	NAND_50S	NAND	F2WP L
HE38	NAND_50S	NAND	F3AD<7...0>
HE39	NAND_50S	NAND	F3CE0 L
HE40	NAND_50S	NAND	F3CE1 L
HE41	NAND_50S	NAND	F3CE2 L
HE42	NAND_50S	NAND	F3CE3 L
HE43	NAND_50S	NAND	F3CLE
HE44	NAND_50S	NAND	F3ALE
HE45	NAND_50S	NAND	F3RE L
HE46	NAND_50S	NAND	F3WE L
HE47	NAND_50S	NAND	F3WP L

JTAG

NET_PHYSICAL_TYPE	AREA_TYPE	PHYSICAL_RULE_SET
JTAG	*	2:1_SPACING

ELECTRICAL_CONSTRAINT_SET	NET_TYPE		
	PHYSICAL	SPACING	
HE0	JTAG	JTAG	JTAG AP TCK 4 28
HE1	JTAG	JTAG	JTAG AP TMS 4 28
HE2	JTAG	JTAG	JTAG AP TDI 4 10
HE3	JTAG	JTAG	JTAG AP TDO 4 10
HE4	JTAG	JTAG	JTAG AP TRST L 4 10

I2C

NET_PHYSICAL_TYPE	AREA_TYPE	PHYSICAL_RULE_SET
I2C_50S	*	50_OHM_SE

NET_SPACING_TYPE1	NET_SPACING_TYPE2	AREA_TYPE	SPACING_RULE_SET
I2C	*	*	1.5:1_SPACING

ELECTRICAL_CONSTRAINT_SET	NET_TYPE		
	PHYSICAL	SPACING	
HE0	I2C_50S	I2C	I2C1 SDA 1V8 5 25
HE1	I2C_50S	I2C	I2C1 SCL 1V8 5 25
HE2	I2C_50S	I2C	I2C0 SDA 1V8 5 10 19 35
HE3	I2C_50S	I2C	I2C0 SCL 1V8 5 10 19 35
HE4	I2C_50S	I2C	I2C2 SDA 3V0 5 25 26
HE5	I2C_50S	I2C	I2C2 SCL 3V0 5 25 26
HE6	I2C_50S	I2C	ISP AP 0 SCL 7 25
HE7	I2C_50S	I2C	ISP AP 0 SDA 7 25
HE8	I2C_50S	I2C	ISP AP 1 SCL 7 26
HE9	I2C_50S	I2C	ISP AP 1 SDA 7 26
HE10	I2C_50S	I2C	I2C2 SCL 3V0 ALS 25 26
HE11	I2C_50S	I2C	I2C2 SDA 3V0 ALS 25 26
HE12	I2C_50S	I2C	ISP CAM 1 SCL 25 26
HE13	I2C_50S	I2C	ISP CAM 1 SDA 25 26

XTAL

NET_PHYSICAL_TYPE	AREA_TYPE	PHYSICAL_RULE_SET
CRYSTAL	*	5:1_SPACING

ELECTRICAL_CONSTRAINT_SET	NET_TYPE		
	PHYSICAL	SPACING	
HE0	CRYSTAL	CRYSTAL	XTAL 24M I 4
HE1	CRYSTAL	CRYSTAL	XTAL 24M O 4
HE2	CRYSTAL	CRYSTAL	24M_O 4

VREF

NET_PHYSICAL_TYPE	AREA_TYPE	PHYSICAL_RULE_SET
VREF	*	5:1_SPACING

ELECTRICAL_CONSTRAINT_SET	NET_TYPE		
	PHYSICAL	SPACING	
HE0	VREF	VREF	PPVREF DDR0 CA 8
HE1	VREF	VREF	PPVREF DDR0 DO 8
HE2	VREF	VREF	PPVREF DDR1 CA 8
HE3	VREF	VREF	PPVREF DDR1 DO 8

USB

NET_PHYSICAL_TYPE	AREA_TYPE	PHYSICAL_RULE_SET
USB_90D	*	90_OHM_DIFP

NET_SPACING_TYPE1	NET_SPACING_TYPE2	AREA_TYPE	SPACING_RULE_SET
USB	*	*	5:1_SPACING

ELECTRICAL_CONSTRAINT_SET	NET_TYPE		
	PHYSICAL	SPACING	
HE0	USB_90D	USB	USB D P 4 28
HE1	USB_90D	USB	USB D N 4 28
HE2	USB_90D	USB	USB PT DK CON D P 28 29
HE3	USB_90D	USB	USB PT DK CON D N 28 29
HE4	USB_90D	USB	USB BB D P 11 31
HE5	USB_90D	USB	USB BB D N 11 31
HE6	USB_90D	USB	USB FS D P 4 11
HE7	USB_90D	USB	USB FS D N 4 11
HE8	USB_90D	USB	USB FS N ACC TX 11 28
HE9	USB_90D	USB	USB FS P ACC RX 11 28
HE10	USB_90D	USB	ACC PT DK CON TX 28 29
HE11	USB_90D	USB	ACC PT DK CON RX 28 29

I2S

NET_PHYSICAL_TYPE	AREA_TYPE	PHYSICAL_RULE_SET
I2S_90S	*	45_OHM_SE

NET_SPACING_TYPE1	NET_SPACING_TYPE2	AREA_TYPE	SPACING_RULE_SET
I2S	*	*	3:1_SPACING
I2S	I2S	*	2:1_SPACING

ELECTRICAL_CONSTRAINT_SET	NET_TYPE		
	PHYSICAL	SPACING	
HE0	I2S_90S	I2S	I2S AP 0 BCLK 5 19
HE1	I2S_90S	I2S	I2S AP 0 LRCK 5 19
HE2	I2S_90S	I2S	I2S AP 0 DIN 5 19
HE3	I2S_90S	I2S	I2S AP 0 DOUT 5 19
HE4	I2S_90S	I2S	I2S AP 2 BCLK 5 19 30
HE5	I2S_90S	I2S	I2S AP 2 LRCK 5 19 30
HE6	I2S_90S	I2S	I2S AP 2 DIN 5 19 30
HE7	I2S_90S	I2S	I2S AP 2 DOUT 5 19 30
HE8	I2S_90S	I2S	I63 ASP SDOUT 19
HE9	I2S_90S	I2S	I2S AP 2 BCLK 5 19 30
HE10	I2S_90S	I2S	I2S AP 2 LRCK 5 19 30
HE11	I2S_90S	I2S	I2S AP 2 DIN 5 19 30
HE12	I2S_90S	I2S	I2S AP 2 DOUT 5 19 30
HE13	I2S_90S	I2S	I63 VSP SDOUT 19
HE14	I2S_90S	I2S	I2S AP 3 BCLK 5 19
HE15	I2S_90S	I2S	I2S AP 3 LRCK 5 19
HE16	I2S_90S	I2S	I2S AP 3 DIN 5 19
HE17	I2S_90S	I2S	I2S AP 3 DOUT 5 19
HE18	I2S_90S	I2S	I63 XSP SDOUT 19

DWI

NET_PHYSICAL_TYPE	AREA_TYPE	PHYSICAL_RULE_SET
DWI	*	2:1_SPACING

ELECTRICAL_CONSTRAINT_SET	NET_TYPE		
	PHYSICAL	SPACING	
HE0	DWI	DWI	DWI AP CLK 5 35
HE1	DWI	DWI	DWI AP DI 5 35
HE2	DWI	DWI	DWI AP DO 5 35

ANALOG VIDEO CONSTRAINTS

PHYSICAL_RULE_SET	LAYER	ALLOW ROUTE ON LAYER?	MINIMUM LINE WIDTH	MINIMUM NECK WIDTH	MAXIMUM NECK LENGTH	DIFFPAIR PRIMARY GAP	DIFFPAIR NECK GAP
VID_50S	*	Y	=50_OHM_SE	=50_OHM_SE	=50_OHM_SE	=STANDARD	=STANDARD

NET_SPACING_TYPE1	NET_SPACING_TYPE2	AREA_TYPE	SPACING_RULE_SET
ANALOG_VIDEO	*	*	5:1_SPACING
ANALOG_VIDEO	ANALOG_VIDEO	*	3:1_SPACING

ELECTRICAL_CONSTRAINT_SET	NET_TYPE		SPACING	NET_NAME	NET_LABEL
	PHYSICAL	SPACING			
E230	VID_50S	ANALOG_VIDEO		DAC AP OUT1	7 11
E230	VID_50S	ANALOG_VIDEO		DAC AP OUT2	7 11
E230	VID_50S	ANALOG_VIDEO		DAC AP OUT3	7 11
E230	VID_50S	ANALOG_VIDEO		BUF C Y	11
E230	VID_50S	ANALOG_VIDEO		BUF CVBS PB	11
E230	VID_50S	ANALOG_VIDEO		BUF Y PR	11
E230	VID_50S	ANALOG_VIDEO		VIDEO EMI CVBS_PB	10 11 28
E230	VID_50S	ANALOG_VIDEO		VIDEO EMI C Y	10 11 28
E230	VID_50S	ANALOG_VIDEO		VIDEO EMI Y PR	10 11 28
E230	VID_50S	ANALOG_VIDEO		VIDEO PT DK CON CVBS_PB	28 29
E230	VID_50S	ANALOG_VIDEO		VIDEO PT DK CON C Y	28 29
E230	VID_50S	ANALOG_VIDEO		VIDEO PT DK CON Y PR	28 29

LVDS

NET_PHYSICAL_TYPE	AREA_TYPE	PHYSICAL_RULE_SET
LVDS_100D	*	90_OHM_DIFF

NET_SPACING_TYPE1	NET_SPACING_TYPE2	AREA_TYPE	SPACING_RULE_SET
LVDS	*	*	4:1_SPACING

ELECTRICAL_CONSTRAINT_SET	NET_TYPE		SPACING	NET_NAME	NET_LABEL
	PHYSICAL	SPACING			
E240	LVDS_100D	LVDS		LVDS DATA P<2..0>	14 16
E240	LVDS_100D	LVDS		LVDS DATA N<2..0>	14 16
E240	LVDS_100D	LVDS		LVDS DATA CONN_P<2..0>	16
E240	LVDS_100D	LVDS		LVDS DATA CONN_N<2..0>	16
E240	LVDS_100D	LVDS		LVDS CLK P	14 16
E240	LVDS_100D	LVDS		LVDS CLK N	14 16
E240	LVDS_100D	LVDS		LVDS CLK CONN_P	16
E240	LVDS_100D	LVDS		LVDS CLK CONN_N	16

DISPLAYPORT

NET_PHYSICAL_TYPE	AREA_TYPE	PHYSICAL_RULE_SET
DP_100D	*	90_OHM_DIFF

NET_SPACING_TYPE1	NET_SPACING_TYPE2	AREA_TYPE	SPACING_RULE_SET
DP	*	*	5:1_SPACING

ELECTRICAL_CONSTRAINT_SET	NET_TYPE		SPACING	NET_NAME	NET_LABEL
	PHYSICAL	SPACING			
E244	DP_100D	DP		DP AP TX P<0>	7 10 13
E244	DP_100D	DP		DP AP TX N<0>	7 10 13
E244	DP_100D	DP		DP AP TX P<1>	7 10 13
E244	DP_100D	DP		DP AP TX N<1>	7 10 13
E244	DP_100D	DP		DP AP AUX P	7 13
E244	DP_100D	DP		DP AP AUX N	7 13
E244	DP_100D	DP		DP EMI TX P<0>	13 28
E244	DP_100D	DP		DP EMI TX N<0>	13 28
E244	DP_100D	DP		DP EMI TX P<1>	13 28
E244	DP_100D	DP		DP EMI TX N<1>	13 28
E244	DP_100D	DP		DP EMI AUX P	13 28
E244	DP_100D	DP		DP EMI AUX N	13 28
E244	DP_100D	DP		DP PT DK CON_TX_P<0>	28 29
E244	DP_100D	DP		DP PT DK CON_TX_N<0>	28 29
E244	DP_100D	DP		DP PT DK CON_TX_P<1>	28 29
E244	DP_100D	DP		DP PT DK CON_TX_N<1>	28 29
E244	DP_100D	DP		DP PT DK CON_AUX_P	28 29
E244	DP_100D	DP		DP PT DK CON_AUX_N	28 29

MIPI

NET_PHYSICAL_TYPE	AREA_TYPE	PHYSICAL_RULE_SET
MIPI_100D	*	90_OHM_DIFF

NET_SPACING_TYPE1	NET_SPACING_TYPE2	AREA_TYPE	SPACING_RULE_SET
MIPI	*	*	4:1_SPACING

ELECTRICAL_CONSTRAINT_SET	NET_TYPE		SPACING	NET_NAME	NET_LABEL
	PHYSICAL	SPACING			
E248	MIPI_100D	MIPI		MIPI AP DATA P<0>	7 14
E248	MIPI_100D	MIPI		MIPI AP DATA N<0>	7 14
E248	MIPI_100D	MIPI		MIPI AP DATA P<1>	7 14
E248	MIPI_100D	MIPI		MIPI AP DATA N<1>	7 14
E248	MIPI_100D	MIPI		MIPI AP DATA P<2>	7 14
E248	MIPI_100D	MIPI		MIPI AP DATA N<2>	7 14
E248	MIPI_100D	MIPI		MIPI AP DATA P<3>	7 14
E248	MIPI_100D	MIPI		MIPI AP DATA N<3>	7 14
E248	MIPI_100D	MIPI		MIPI AP CLK P	7 14
E248	MIPI_100D	MIPI		MIPI AP CLK N	7 14
E248	MIPI_100D	MIPI		MIPI OC AP DATA P<0>	7 27
E248	MIPI_100D	MIPI		MIPI OC AP DATA N<0>	7 27
E248	MIPI_100D	MIPI		MIPI OC AP CLK P	7 27
E248	MIPI_100D	MIPI		MIPI OC AP CLK N	7 27
E248	MIPI_100D	MIPI		MIPI OC CAM DATA P<0>	25 27
E248	MIPI_100D	MIPI		MIPI OC CAM DATA N<0>	25 27
E248	MIPI_100D	MIPI		MIPI OC CAM CLK P	25 27
E248	MIPI_100D	MIPI		MIPI OC CAM CLK N	25 27
E248	MIPI_100D	MIPI		MIPI IC AP DATA P<0>	7 26
E248	MIPI_100D	MIPI		MIPI IC AP DATA N<0>	7 26
E248	MIPI_100D	MIPI		MIPI IC AP CLK P	7 26
E248	MIPI_100D	MIPI		MIPI IC AP CLK N	7 26
E248	MIPI_100D	MIPI		MIPI IC CAM DATA P<0>	25 26
E248	MIPI_100D	MIPI		MIPI IC CAM DATA N<0>	25 26
E248	MIPI_100D	MIPI		MIPI IC CAM CLK P	25 26
E248	MIPI_100D	MIPI		MIPI IC CAM CLK N	25 26

AUDIO/SPEAKER

NET_PHYSICAL_TYPE	AREA_TYPE	PHYSICAL_RULE_SET
AUDIO	*	1:1_DIFFPAIR
SPEAKER	*	SPEAKER

NET_SPACING_TYPE1	NET_SPACING_TYPE2	AREA_TYPE	SPACING_RULE_SET
AUDIO	*	*	3:1_SPACING

ELECTRICAL_CONSTRAINT_SET	NET_TYPE		SPACING	NET_NAME	NET_LABEL
	PHYSICAL	SPACING			
E250	AUDIO	AUDIO		LEFT CH OUT P	19 20
E250	AUDIO	AUDIO		LEFT CH OUT REF	19 20
E250	AUDIO	AUDIO		LEFT CH P	20
E250	AUDIO	AUDIO		SSM2375 L IN P	20
E250	AUDIO	AUDIO		SSM2375 L IN N	20
E250	AUDIO	AUDIO		RIGHT CH OUT P	19 20
E250	AUDIO	AUDIO		RIGHT CH OUT REF	19 20
E250	AUDIO	AUDIO		RIGHT CH P	20
E250	AUDIO	AUDIO		SSM2375 R IN P	20
E250	AUDIO	AUDIO		SSM2375 R IN N	20
E250	AUDIO	AUDIO		EXT MIC P	19 23
E250	AUDIO	AUDIO		EXT MIC REF	19 23

SDIO

NET_PHYSICAL_TYPE	AREA_TYPE	PHYSICAL_RULE_SET
SDIO_50S	*	50_OHM_SE

NET_SPACING_TYPE1	NET_SPACING_TYPE2	AREA_TYPE	SPACING_RULE_SET
SDIO	*	*	2:1_SPACING

ELECTRICAL_CONSTRAINT_SET	NET_TYPE		SPACING	NET_NAME	NET_LABEL
	PHYSICAL	SPACING			
E252	SDIO_50S	SDIO_CLK		SDIO WL_CLK	5 30
E252	SDIO_50S	SDIO_CLK		SDIO WL_CLK R	5 30
E252	SDIO_50S	SDIO		SDIO WL_CMD	5 30
E252	SDIO_50S	SDIO		SDIO WL_DATA<3..0>	5 30

SPI

NET_PHYSICAL_TYPE	AREA_TYPE	PHYSICAL_RULE_SET
SPI_50S	*	45_OHM_SE

NET_SPACING_TYPE1	NET_SPACING_TYPE2	AREA_TYPE	SPACING_RULE_SET
SPI	*	*	2:1_SPACING

ELECTRICAL_CONSTRAINT_SET	NET_TYPE		SPACING	NET_NAME	NET_LABEL
	PHYSICAL	SPACING			
E254	SPI_50S	SPT		SPI GRAPE MISO	5 17
E254	SPI_50S	SPT		SPI GRAPE MOSI	5 17
E254	SPI_50S	SPT		SPI GRAPE SCLK	5 17
E254	SPI_50S	SPT		SPI GRAPE CS L	5 17
E254	SPI_50S	SPT		SPI IPC MISO	5 31
E254	SPI_50S	SPT		SPI IPC MOSI	5 31
E254	SPI_50S	SPT		SPI IPC SCLK	5 31
E254	SPI_50S	SPT		SPI IPC MRDY	5 31

www.laptop-schematics.com

SYNC MASTER=MIKE		SYNC DATE=N/A	
CONSTRAINTS: ASSIGNMENTS			
Apple Inc.	DRAWING NUMBER	051-8962	SIZE D
	REVISION	A.0.0	
NOTICE OF PROPRIETARY PROPERTY:		BRANCH	
THE INFORMATION CONTAINED HEREIN IS THE PROPRIETARY PROPERTY OF APPLE COMPUTER, INC. THE POSSESSOR AGREES TO THE FOLLOWING:		PAGE	
I TO MAINTAIN THIS DOCUMENT IN CONFIDENCE		101 OF 106	
II NOT TO REPRODUCE OR COPY IT		SHEET	
III NOT TO REVEAL OR PUBLISH IT IN WHOLE OR PART		40 OF 42	
IV ALL RIGHTS RESERVED			

MLB CONSTRAINTS

BOARD LAYERS	BOARD AREAS	BOARD UNITS (MIL OR MM)	ALLEGRO VERSION
TOP, ISL2, ISL3, ISL4, ISL5, ISL6, ISL7, ISL8, ISL9, BOTTOM	NO_TYPE, BGA, BGA06-06	MM	15.2

PHYSICAL CONSTRAINTS

PHYSICAL_RULE_SET	LAYER	ALLOW ROUTE ON LAYER?	MINIMUM LINE WIDTH	MINIMUM NECK WIDTH	MAXIMUM NECK LENGTH	DIFFPAIR PRIMARY GAP	DIFFPAIR NECK GAP
DEFAULT	*	Y	=45_OHM_SE	=45_OHM_SE	30 MM	0 MM	0 MM
STANDARD	*	Y	=DEFAULT	=DEFAULT	12.7 MM	=DEFAULT	=DEFAULT

SINGLE-ENDED PHYSICAL RULES 45 OHMS

PHYSICAL_RULE_SET	LAYER	ALLOW ROUTE ON LAYER?	MINIMUM LINE WIDTH	MINIMUM NECK WIDTH	MAXIMUM NECK LENGTH	DIFFPAIR PRIMARY GAP	DIFFPAIR NECK GAP
45_OHM_SE	ISL2, ISL3, ISL8, ISL9	Y	0.055 MM	0.055 MM	3.0 MM		
45_OHM_SE	ISL4, ISL5, ISL6, ISL7	Y	0.060 MM	0.060 MM	3.0 MM		
45_OHM_SE	*	N	0.060 MM	0.060 MM	3.0 MM		

50 OHMS

PHYSICAL_RULE_SET	LAYER	ALLOW ROUTE ON LAYER?	MINIMUM LINE WIDTH	MINIMUM NECK WIDTH	MAXIMUM NECK LENGTH	DIFFPAIR PRIMARY GAP	DIFFPAIR NECK GAP
50_OHM_SE	TOP, BOTTOM	Y	0.085 MM	0.085 MM	3.0 MM		
50_OHM_SE	*	N	0.050 MM	0.050 MM	3.0 MM		

50 OHMS - CLEAR ON LAYER 2 AND 5

PHYSICAL_RULE_SET	LAYER	ALLOW ROUTE ON LAYER?	MINIMUM LINE WIDTH	MINIMUM NECK WIDTH	MAXIMUM NECK LENGTH	DIFFPAIR PRIMARY GAP	DIFFPAIR NECK GAP
50_OHM_SE_RF	TOP	Y	0.240 MM	0.240 MM	3.0 MM		
50_OHM_SE	ISL4	Y	0.060 MM	0.060 MM	3.0 MM		

50 OHMS - CLEAR ON TOP AND BOTTOM

PHYSICAL_RULE_SET	LAYER	ALLOW ROUTE ON LAYER?	MINIMUM LINE WIDTH	MINIMUM NECK WIDTH	MAXIMUM NECK LENGTH	DIFFPAIR PRIMARY GAP	DIFFPAIR NECK GAP
50_OHM_SE	ISL2, ISL9	Y	0.090 MM	0.090 MM	3.0 MM		

DIFFERENTIAL PAIR PHYSICAL RULES

100 OHMS

PHYSICAL_RULE_SET	LAYER	ALLOW ROUTE ON LAYER?	MINIMUM LINE WIDTH	MINIMUM NECK WIDTH	MAXIMUM NECK LENGTH	DIFFPAIR PRIMARY GAP	DIFFPAIR NECK GAP
100_OHM_DIFF	TOP, BOTTOM	Y	0.076 MM	0.076 MM		0.210 MM	0.210 MM
100_OHM_DIFF	N	Y	0.057 MM	0.057 MM	=STANDARD	0.300 MM	0.300 MM

90 OHMS

PHYSICAL_RULE_SET	LAYER	ALLOW ROUTE ON LAYER?	MINIMUM LINE WIDTH	MINIMUM NECK WIDTH	MAXIMUM NECK LENGTH	DIFFPAIR PRIMARY GAP	DIFFPAIR NECK GAP
90_OHM_DIFF	TOP, BOTTOM	Y	0.095 MM	0.095 MM		0.200 MM	0.200 MM
90_OHM_DIFF	ISL2, ISL3, ISL8, ISL9	Y	0.054 MM	0.054 MM	=STANDARD	0.200 MM	0.100 MM
90_OHM_DIFF	ISL4, ISL5, ISL6, ISL7	Y	0.060 MM	0.060 MM	=STANDARD	0.200 MM	0.100 MM

AUDIO PHYSICAL RULES

PHYSICAL_RULE_SET	LAYER	ALLOW ROUTE ON LAYER?	MINIMUM LINE WIDTH	MINIMUM NECK WIDTH	MAXIMUM NECK LENGTH	DIFFPAIR PRIMARY GAP	DIFFPAIR NECK GAP
1:1_DIFFPAIR	*	Y	=STANDARD	=STANDARD	=STANDARD	0.08 MM	0.08 MM
SPEAKER	*	Y	0.3 MM	0.19MM	10 MM	0.08 MM	0.08 MM

BGA AREA PHYSICAL RULES

NET_PHYSICAL_TYPE	AREA_TYPE	PHYSICAL_RULE_SET
*	BGA	BGA_PHY

PHYSICAL_RULE_SET	LAYER	ALLOW ROUTE ON LAYER?	MINIMUM LINE WIDTH	MINIMUM NECK WIDTH	MAXIMUM NECK LENGTH	DIFFPAIR PRIMARY GAP	DIFFPAIR NECK GAP
BGA_PHY	*	Y	0.060 MM	0.060 MM	=STANDARD	0.076 MM	0.075 MM

SPACING CONSTRAINTS

DEFAULT/BGA SPACING RULES

SPACING_RULE_SET	LAYER	LINE-TO-LINE SPACING	WEIGHT
DEFAULT	*	0.08 MM	?
STANDARD	*	=DEFAULT	?
BGA_SPA	*	=DEFAULT	?

REGULAR SPACING RULES

SPACING_RULE_SET	LAYER	LINE-TO-LINE SPACING	WEIGHT
1:1_SPACING	*	0.060 MM	?
0P08_SPACING	*	0.080 MM	?
1.5:1_SPACING	*	0.090 MM	?
2:1_SPACING	*	0.120 MM	?
2.5:1_SPACING	*	0.150 MM	?
3:1_SPACING	*	0.180 MM	?
4:1_SPACING	*	0.240 MM	?
5:1_SPACING	*	0.300 MM	?
0P5MM_SPACING	*	0.5 MM	?
0P64MM_SPACING	*	0.64 MM	?

*NOTE: ASSUMING 0.060MM DIELECTRIC THICKNESS

POWER/GND SPACING RULES

SPACING_RULE_SET	LAYER	LINE-TO-LINE SPACING	WEIGHT
PWR_P1SPACING	*	0.1 MM	900
GND_P1SPACING	*	0.1 MM	950
SWITCHNODE	*	0.5 MM	1000
SWITCHNODE	TOP, BOTTOM	0.2 MM	1000

NET_SPACING_TYPE1	NET_SPACING_TYPE2	AREA_TYPE	SPACING_RULE_SET
*	*	BGA	BGA_SPA
CLK	*	BGA	BGA_SPA
PWR	*	*	PWR_P1SPACING
GND	*	*	GND_P1SPACING
SWITCHNODE	*	*	SWITCHNODE
ANLG	*	*	3:1_SPACING

NOTES:

- 0.075 MM ~ 3 MIL
- 0.089 MM ~ 3.5 MIL
- 0.102 MM ~ 4 MIL
- 0.114 MM ~ 4.5 MIL
- 0.125 MM ~ 5 MIL
- 0.140 MM ~ 5.5 MIL
- 0.15 MM ~ 6 MIL
- 0.18 MM ~ 7 MIL
- 0.2 MM ~ 8 MIL
- 0.25 MM ~ 10 MIL
- 0.3 MM ~ 12 MIL
- 0.33 MM ~ 13 MIL
- 0.4 MM ~ 16 MIL
- 1.0 MM = 39.37 MIL

www.laptop-schematics.com

SYNC MASTER=MIKE		SYNC DATE=N/A	
CONSTRAINTS: MLB RULES			
Apple Inc.		DRAWING NUMBER	051-8962
		REVISION	A.0.0
NOTICE OF PROPRIETARY PROPERTY:		BRANCH	
THE INFORMATION CONTAINED HEREIN IS THE PROPRIETARY PROPERTY OF APPLE COMPUTER, INC. THE POSSESSOR AGREES TO THE FOLLOWING:		PAGE	102 OF 106
I TO MAINTAIN THIS DOCUMENT IN CONFIDENCE		SHEET	41 OF 42
II NOT TO REPRODUCE OR COPY IT			
III NOT TO REVEAL OR PUBLISH IT IN WHOLE OR PART			
IV ALL RIGHTS RESERVED			

www.laptop-schematics.com

SYNC MASTER=MIKE		SYNC DATE=N/A	
CONSTRAINTS: RF RULES			
DRAWING NUMBER		SIZE	
051-8962		D	
REVISION			
A.0.0			
NOTICE OF PROPRIETARY PROPERTY:		BRANCH	
THE INFORMATION CONTAINED HEREIN IS THE PROPRIETARY PROPERTY OF APPLE COMPUTER, INC. THE POSSESSOR AGREES TO THE FOLLOWING:			
I TO MAINTAIN THIS DOCUMENT IN CONFIDENCE		PAGE	
II NOT TO REPRODUCE OR COPY IT		106 OF 106	
III NOT TO REVEAL OR PUBLISH IT IN WHOLE OR PART		SHEET	
IV ALL RIGHTS RESERVED		42 OF 42	