



Upgrades

Power Macintosh G3/Macintosh
Server G3 (Blue and White)





DRAM Upgrade

The Power Macintosh G3/ Macintosh Server G3 (Blue and White) can be expanded to a maximum of 1024 MB by adding DIMMs to any of the four DRAM DIMM slots on the main logic board. DIMMs from older Macintosh computers may physically fit in the slots, but they are not compatible and should not be used.

Different size DRAM DIMMs can be installed in any order in any DIMM slot. They do

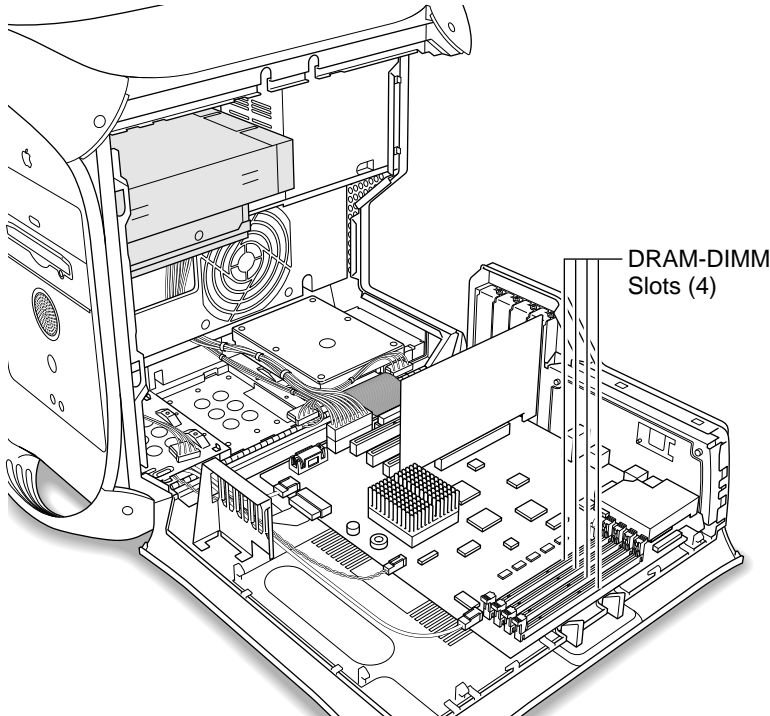



not need to be installed in pairs. It is recommended that DIMMs be installed in the first slot available closest to the center of the board (J-19), then adjacent slots J-20, J-21, and J-22.

Compatible DRAM DIMMs must meet all the following specifications:

- PC-100 Synchronous DRAM (SDRAM)
- 3.3 volt
- 64-bit wide, 168-pin module
- maximum of 16 memory devices on the DIMM
- unbuffered; do not use registered or buffered Synchronous DRAM (SDRAM)
- maximum height of 2.0 inches.

To increase DRAM to the maximum of 1024 MB, fill all four slots with 256 MB DIMMs. Any 256 MB DIMMs installed must use 128 megabit (Mbit) device technology.





DRAM DIMM Installation

- 1 Lift the latch on the right side of the computer.
- 2 Lower the access panel onto a clean, flat surface.

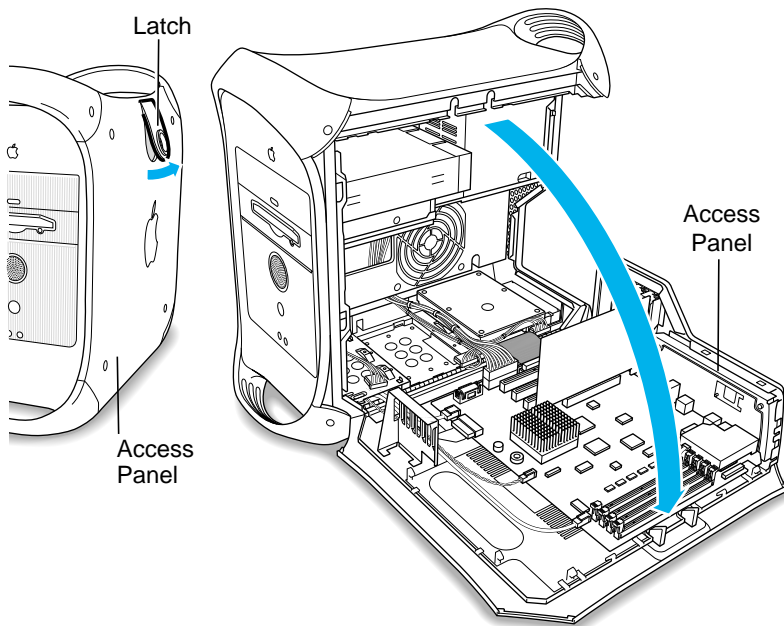

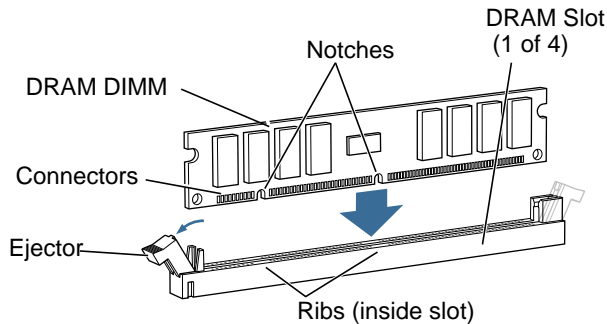

- 3 Align a DRAM DIMM in the DRAM slot so the notches line up with the ribs inside the slot.
- 4 Push the DIMM down evenly until the ejectors snap into place.

Note: To remove a DIMM, push down on the slot's ejectors until they open and release the DIMM. Some DRAM slots may have only one ejector.





Drive Upgrades

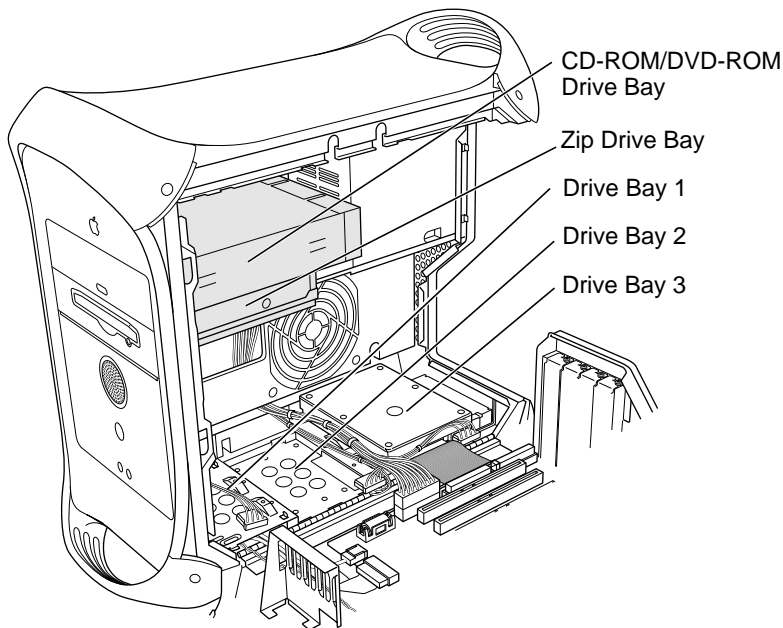

The Power Macintosh G3/ Macintosh Server G3 (Blue and White) has five internal drive bays: three in the lower part of the computer and two in front on top.

Standard Macintosh configurations include one internal Ultra ATA hard drive, or one, two, or three internal Ultra2 LVD SCSI drives.





Ultra ATA Drives

The Power Macintosh G3/Macintosh Server G3 (Blue and White) can accommodate either one or two internal Ultra ATA drives in the lower part of the computer, drive bay 3. (The U-shaped carrier, available for version 2 enclosures, allows installation of two ATA drives, stacked vertically.)

Ultra2 LVD SCSI Drives

Connect internal and external Ultra2 LVD SCSI devices using an internal PCI card and cable. You can connect up to three internal SCSI drives (all in the lower drive area), or connect additional SCSI devices to the port the card provides on the rear of the computer.

Other SCSI Drives

The Ultra2 LVD SCSI card supports other types of Wide Ultra SCSI drives besides the Ultra2 LVD SCSI drive.





However, the system will operate at the speed of the slowest device. For optimal performance using the Ultra2 LVD SCSI card, use only Ultra2 LVD SCSI devices. To maintain optimal performance using another kind of SCSI device, add a PCI card that supports the device.

Supported Drives

The Power Macintosh G3/Macintosh Server G3 (Blue and White) supports a maximum of three internal hard drives. Supported drives include:

- ATA devices (includes ATA, ATA-2, and ATA-3 devices, which are also called IDE or EIDE devices)
- Ultra ATA devices (sometimes called ATA-4 devices)
- Wide Ultra SCSI devices (with the PCI card included in some configurations)
- Ultra2 LVD SCSI devices (with the PCI card included in some configurations)



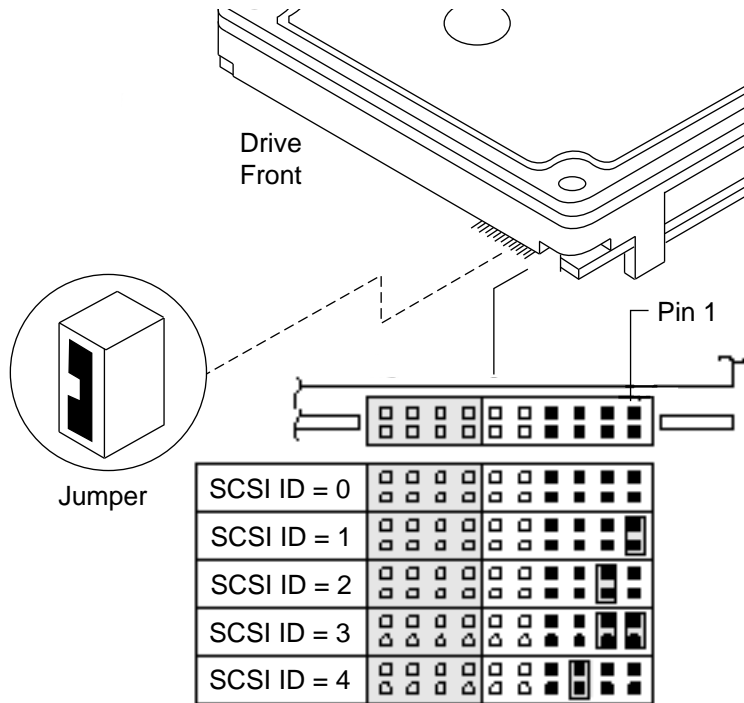

- ATAPI drives, including CD-ROM, DVD-ROM, and Zip drives.

SCSI ID Numbers

If the computer came with one Ultra2 LVD SCSI drive, it has SCSI ID 0. If you are adding SCSI drives, the second drive is ID 1 and the third drive is ID 2. See the illustration for placing the jumper for ID 1 and 2.

Note: The SCSI PCI card is ID 7. The drive in position 1 is the startup drive.





SCSI Drive Upgrade Procedure

Before you begin, open the side access panel.

Note: This procedure is based on computers using version 1 hard drive carriers. For version 2 hard drive carriers, see the version 2 instructions in the Take Apart hard drive topics.

- 1 Unplug the bundled power cable and the ribbon cable from the logic board for any

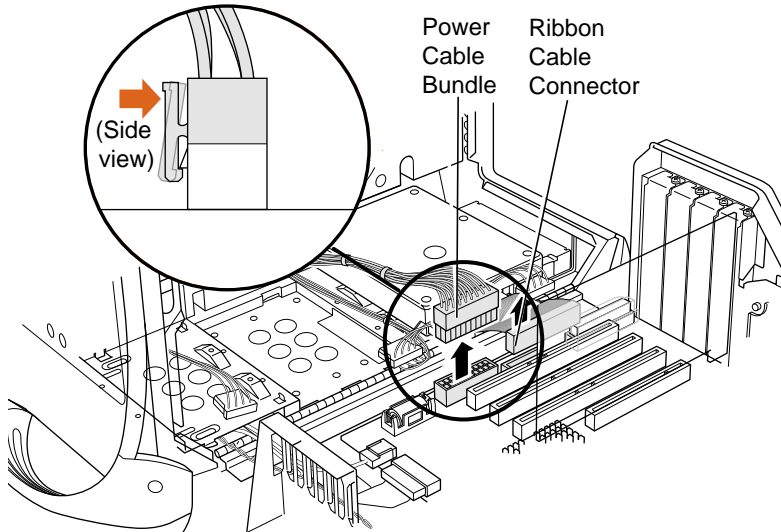

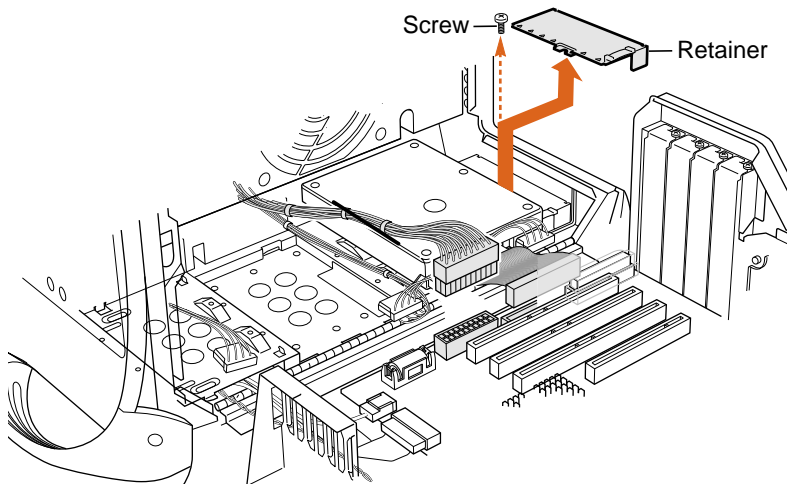

installed ATA drives.

- 2 Disconnect the ribbon cable from the PCI card for any installed SCSI drives.
- 3 Remove the screw from the rear of the drive carrier and remove the drive carrier retainer.



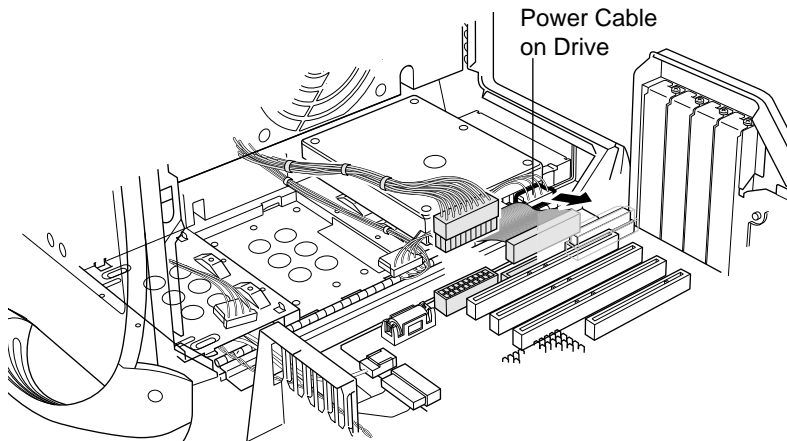

- 4 Unplug the power cord from any hard drives attached to the drive carrier.
- 5 Slide the drive carrier assembly toward the rear of the computer and lift it out.
- 6 Assign a unique SCSI ID number to the drive being installed. See "SCSI ID Numbers" earlier in this chapter for more information.



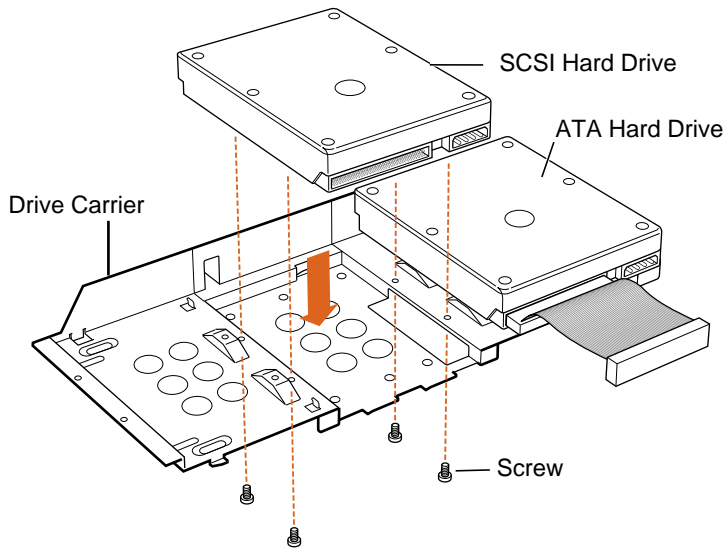

- 7 Position the drive so that the drive's connectors face away from the sheet metal side of the drive carrier.
- 8 Screw the drive to the drive carrier with four screws.
- 9 Connect the appropriate cable to the drive.

Note: If you are installing a third-party SCSI card and cable, refer to the owner's manual that came with the card.



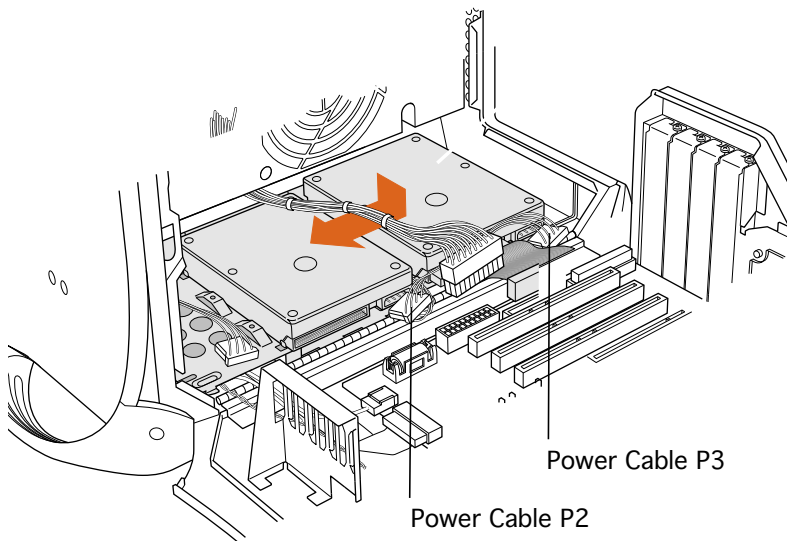

Note: The SCSI cable included with factory-installed SCSI drives has a built-in terminator block, so no terminator is needed.

- 10 Replace the drive carrier and slide it toward the front of the computer until it locks into position. Do not crimp any wires that are near or under the assembly.
- 11 Replace the drive carrier retainer and screw it back in place.





12 Plug the power cables into the hard ddrives.

13 Reconnect the main power cable bundle and the drives' ribbon cable.

Note: If you added a SCSI drive to a computer that came with an ATA drive, attach the main power cable bundle and the ATA ribbon cable to the main logic board and the SCSI ribbon cable to the SCSI PCI card.

If you added a SCSI drive to a computer that came with one or two SCSI drives, attach the main power cable bundle to the main logic board and the SCSI ribbon cable to the SCSI PCI card.





Sample SCSI Hard Drive and Cable Configurations

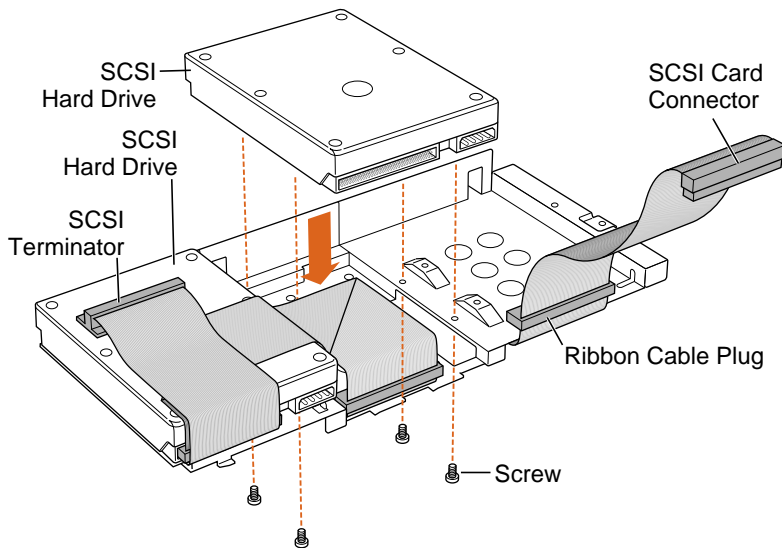

To install a SCSI hard drive in drive bay 3, attach the ribbon cable plug to the ribbon cable connector on the drive.

To install a SCSI hard drive in drive bay 2, put the ribbon cable on top of the drive and attach the ribbon cable plug to the ribbon cable connector on the drive. You can tape the ribbon cable to the top of the drive





with double-stick foam tape to make it lie flat.

For maximum performance, use Ultra2 devices on an Ultra2 PCI card.





Zip Drive Upgrade

Before you begin, open the side access panel.

The Zip drive upgrade kit includes an internal Zip drive, Zip drive bezel, and mounting screws.

Install the Zip drive by following the procedures under “CD-ROM/DVD-ROM/DVD-RAM/Zip Drive Bezel” and “Zip Drive” in the Take Apart chapter.

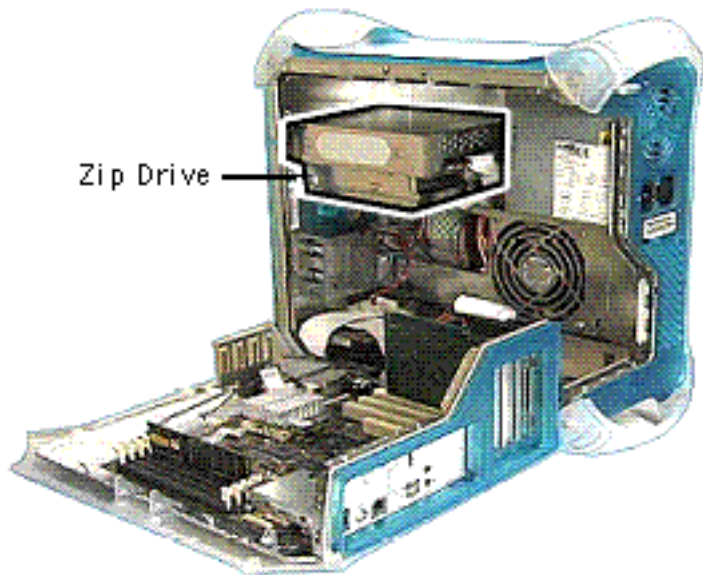



PCI Expansion Cards

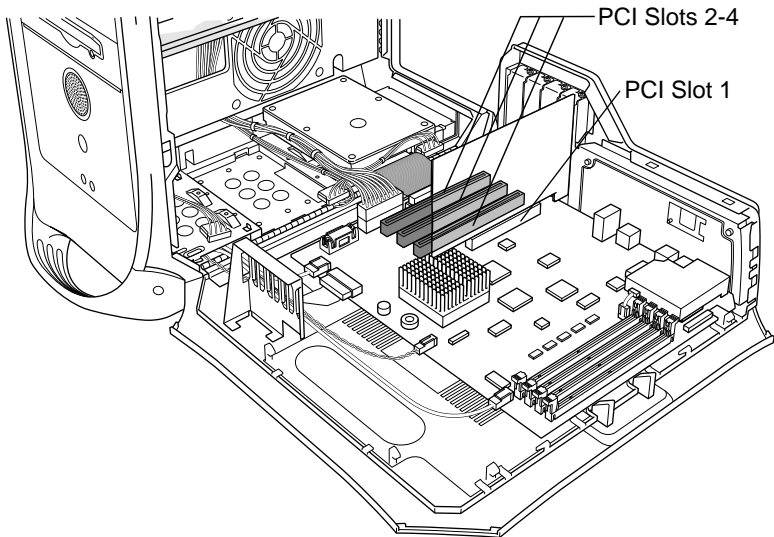

The Power Macintosh G3/ Macintosh Server G3 (Blue and White) has four expansion slots that accept PCI cards up to 12 inches long. Install only expansion cards that come with Macintosh driver software and that comply with the PCI 2.1 standard. NuBus cards cannot be used in these expansion slots.

In standard Macintosh models, a graphics card that





supplies a monitor port occupies PCI slot 1. This slot can accommodate 3.3 volt cards with 66 MHz frequency and 32-bit data widths only.

PCI slots 2, 3, and 4 can accommodate mixed voltage (5.0 V or 3.3 V) cards with a 33 MHz frequency and 32-bit or 64-bit data widths. These slots will not accommodate 66 MHz cards.





PCI Card Installation

Before you begin, open the computer using the procedures in the Take Apart chapter of this manual.

- 1 Remove the port access cover screw.
- 2 Remove the port access cover.

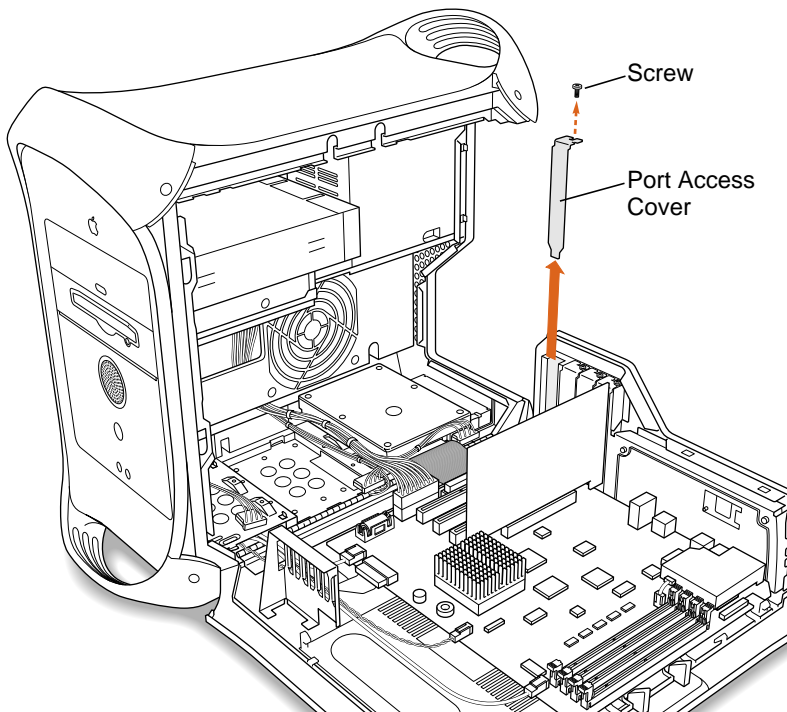

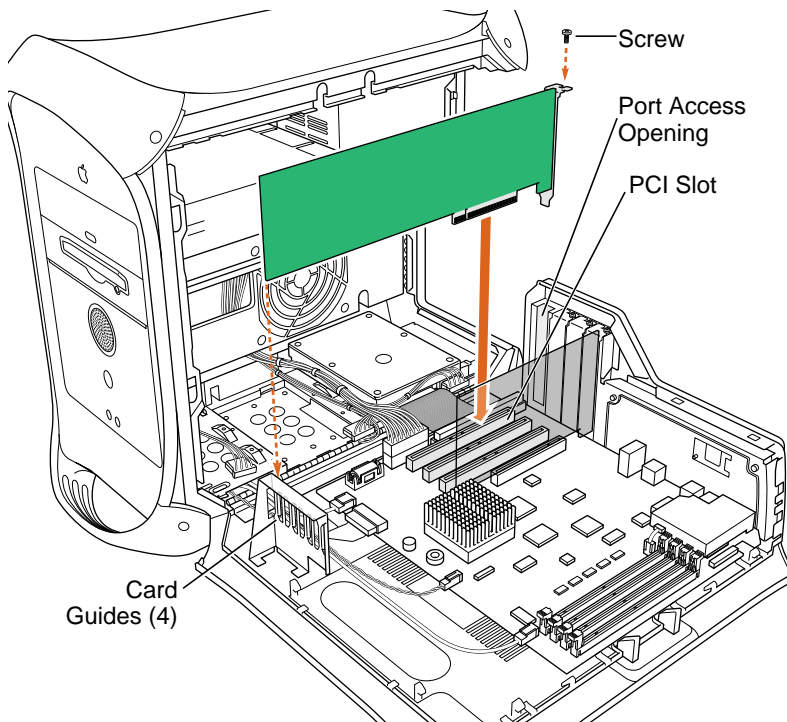

- 3 Align the PCI card's connector with the expansion slot and press down firmly until the card is seated in the slot.

Note: If the card is full-length (12"), fit the end in one of the four card guides at the front of the computer.

- 4 Use the port access cover screw to secure the PCI card to the port access opening.
- 5 If you removed a card and are not replacing it, replace the port access





cover and the port access cover screw.

Note: Do not leave an empty PCI slot uncovered. An uncovered port can affect the air flow to the computer's components.

Replacement Note: If you are replacing an Xclaim VR PCI card that includes an additional memory module with a new Xclaim VR card, transfer the memory module from the original card to the new card before installing it in the computer. The memory module connector is keyed to ensure correct orientation with the card's memory slot; do not force the module into the slot. Simply align the notch in the connector with the small plastic tab in the slot; then push in and down on the memory module until the two plastic latches on the side of the slot lock into place.

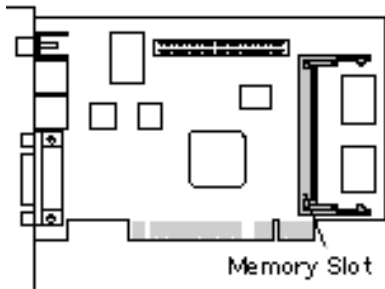

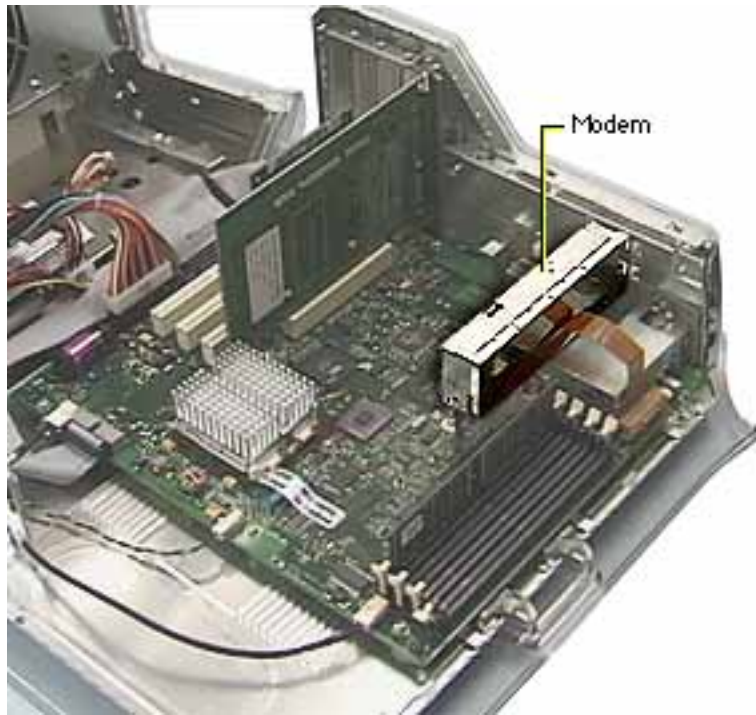

Modem Installation

Note: If you're installing the modem upgrade kit, continue with these procedures. If you are removing or replacing a faulty modem, refer to the "Modem" section in the Take Apart chapter.





- 1 Open the side access panel.



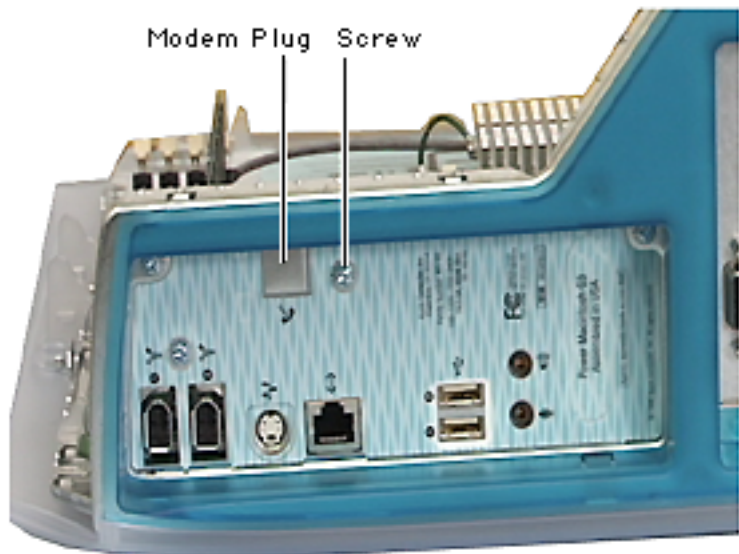

- 2 Remove the screw that secures the modem plug on the I/O panel.
- 3 Remove the modem plug.
- 4 Position the modem so the modem port connector aligns with the modem hole on the I/O panel.



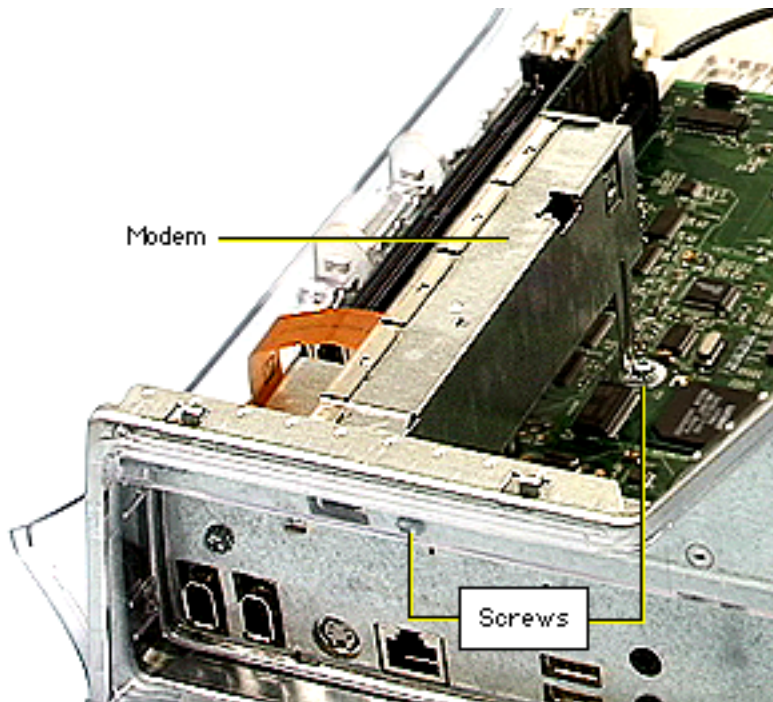

- 5 Secure the two modem screws. One screw attaches to the logic board, and the other attaches to the I/O panel.



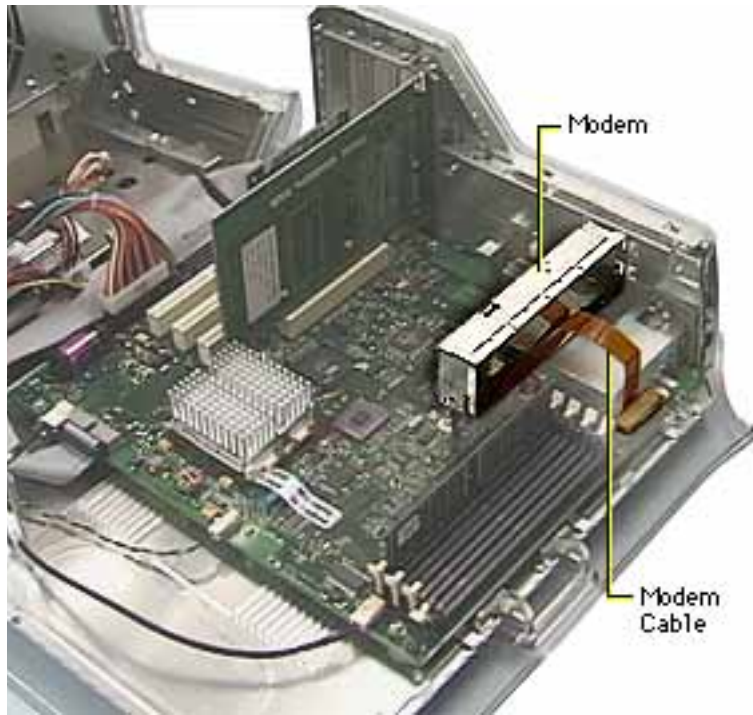

- 6 Carefully connect the flexible modem cable to the logic board.
- 7 Close the side access panel.

